

GISW

housing: heat-treating steel to C22, forged, zinc plated
insert: free-cutting steel to 11SMnPb30C, zinc plated
ball: bearing steel to 100Cr6, hardened, ground, polished

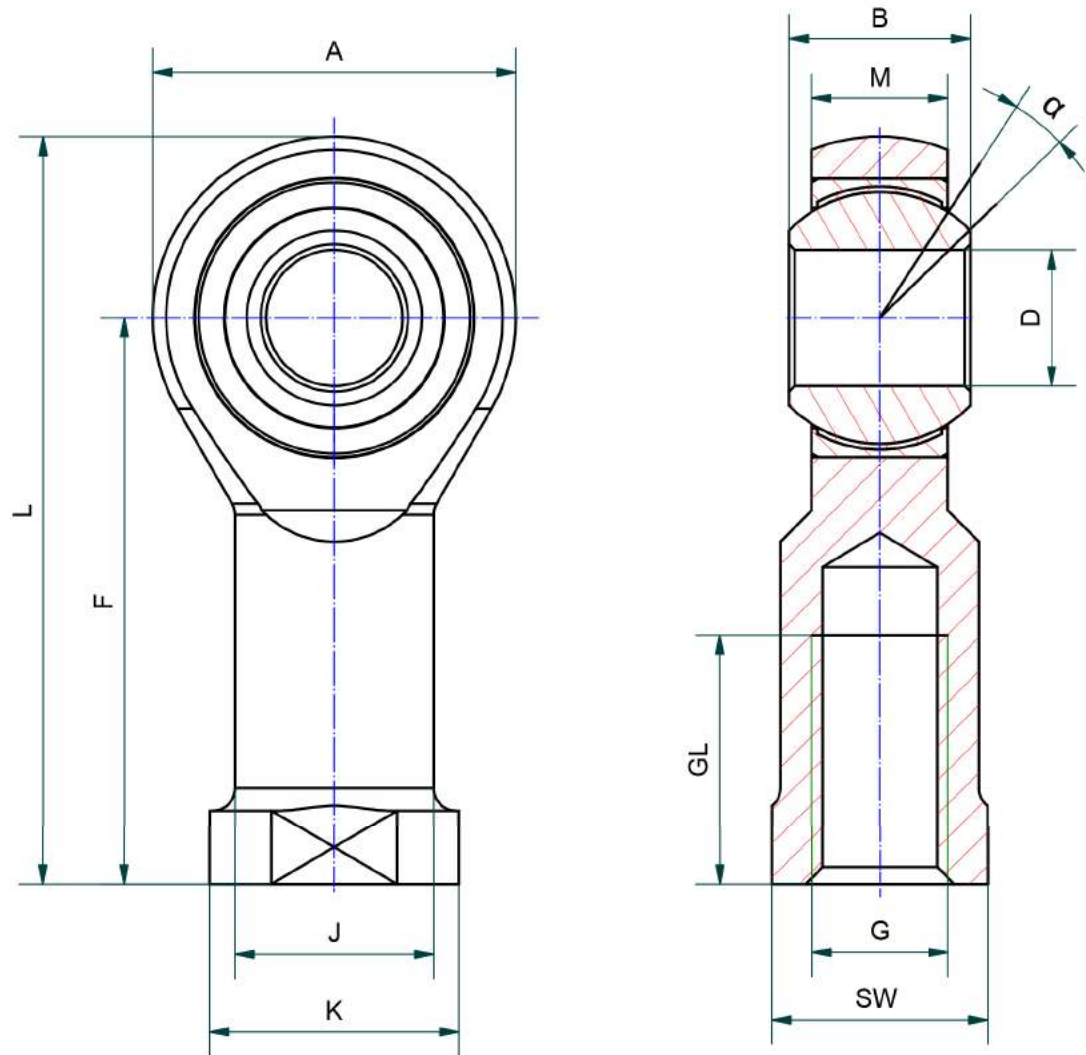

part	D (H7)	B	M	A	F	L	K	J	SW	G	GL	static load C0 (kN)	dynamic load C (kN)	α
GISW20x2,5	20	25	18	50	77	102	34	27,5	32	M20x2,5	33	44	78	14