

Characteristics

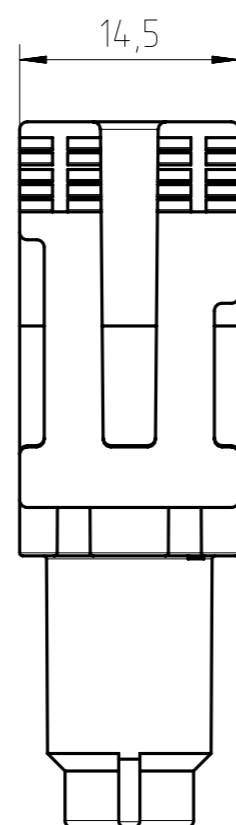
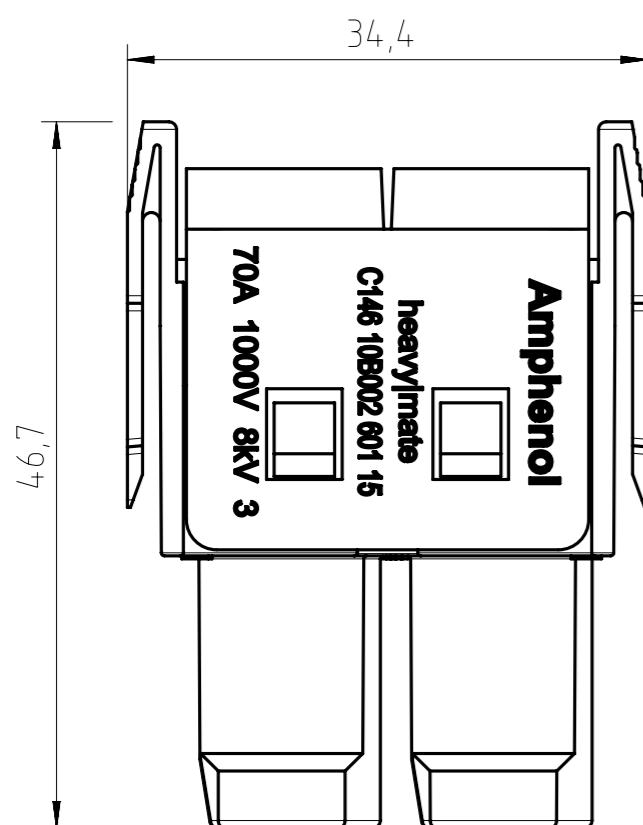
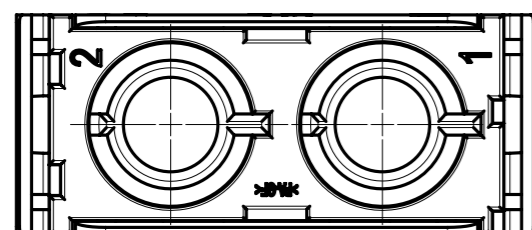
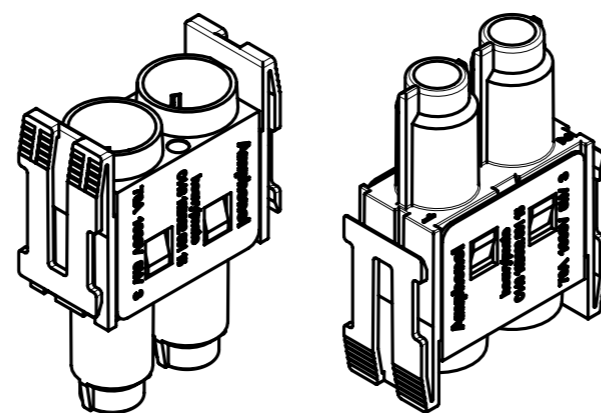

General Characteristics	Standard	Value
number of contacts		2
termination technique		crimp
wire gauge		10 mm ² - 25 mm ² AWG 8 - AWG 4
max. Isolationsdurchmesser		11,4 mm
flammability	UL 94	V-0
Electrical Characteristics	Standard	Value
rated voltage	IEC 60664-1	1000 V
pollution degree	IEC 60664-1	3
installation (overvoltage) category	IEC 60664-1	3
material group	IEC 60664-1	1
rated impulse withstand voltage	IEC 60664-1	8 kV
rated current T _{amb} = 40 °C		70 A
current carrying capacity	IEC 60512-5-2	see derating curve
contact resistance	IEC 60512-2-1	≤ 5 mΩ
insulation resistance	IEC 60512-3-1	≥ 10 ¹⁰ Ω
Climatical Characteristics	Standard	Value
climatic category	IEC 60068-1	40 / 125 / 10
upper temperature	IEC 60512-11-9	+125 °C
lower temperature	IEC 60512-11-10	-40 °C
Mechanical Characteristics	Standard	Value
mechanical operation	IEC 60512-9-1	≥500 mating cycles
Materials	Standard	Value
insert		PA-GF
contacts		CuZn (brass)
contact plating		Ag (silver)
color		black

Nach erfolgter Montage können die Crimpkontakte nicht wieder demontiert werden
after assembly of the crimp contacts into the module the contacts can not be disassembled

Alle technischen Daten wurden unter Laborbedingungen ermittelt und können im Praxisbetrieb abweichen.
Es handelt sich bei den Angaben weder um Beschaffenheits- noch um Haltbarkeitsgarantien.
All technical data have been measured in a laboratory environment and can be different during practical usage of the product. Any product information is for descriptive usage only and not legally binding; particularly the information does not constitute or provide any legal guarantees ("Beschaffenheitsgarantie" or "Haltbarkeitsgarantie").

Gewicht (errechnet) / Calc WT: 9,4 g		Zul. Abw./Tolerances:		Maßstab / Scale: 2:1 (1:1)		A3							
Prüfmaß / Testdimension		ISO 2768-m		DIN / ISO 13715		<h2>CUSTOMER DRAWING</h2>							
Teileindex / Partindexnumber:													
Bagatelle change:						<h3>Buchsenmodul 2-Pol</h3> <h3>socket module 2 pole</h3>							
		Gez. 09.05.2018											
		Drawn PWOLFFLE											
		Status Released				<h2>M C146 10B002 601 15</h2>							
		Gepr. 15.06.2018											
		Checked MGRIMM				<table border="1"> <tr> <td>Blatt / Sheet</td> <td>1</td> </tr> <tr> <td>1 Bl.</td> <td></td> </tr> </table>				Blatt / Sheet	1	1 Bl.	
Blatt / Sheet	1												
1 Bl.													
01 201500755		28.05.2018		PWOLF		Ers. f. / Replacement for:							
Index		Änderung / Description		Datum / Date						Name			

Coping of this document and giving it to others and the use or communication of the contents thereof, are forbidden without express authority. Offenders are liable to the payment of damages. All rights are reserved in the event of the grant of a patent or the registration of the utility model or design.

Weitergabe sowie Vervielfältigung dieser Unterlage, Verwertung und Mitteilung ihres Inhalts nicht gestattet, soweit nicht ausdrücklich zugestanden. Zuwiderhandlungen verpflichten zu Schadenersatz. Alle Rechte für den Fall der Patenterteilung oder Gebrauchsmuster-Eintragung vorbehalten.

FAI2018-002323