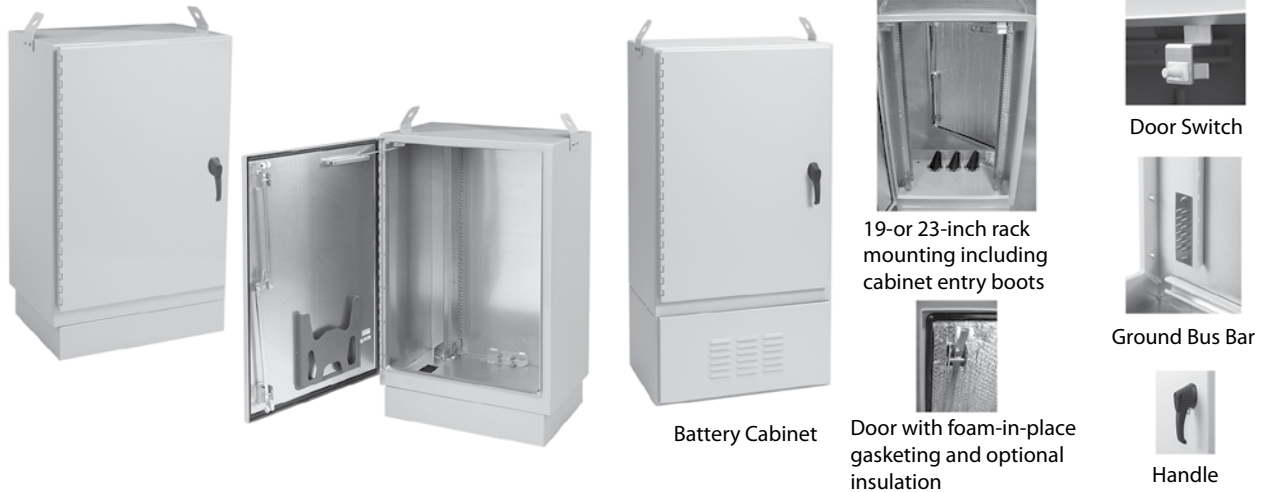

FTTX FIBER OPTIC CABINET PACKAGE, TYPE 4X

INDUSTRY STANDARDS

UL 508A Listed; Type 3, 3R, 4, 4X, 12; File No. E61997
--

CSA: Type 3, 3R, 4, 4X, 12

NEMA/EEMAC Type 3, 3R, 4, 4X, 12

EC60529, IP66

Designed to meet Telcordia NEBS™ GR-487, GR-63 and IEC 48D EIA 310-D with 19-in. spacing for rack equipment

Cabinet is RoHS compliant

NEBS™ is a trademark of Telcordia

APPLICATION

Pad-mounted FTTX welded aluminum enclosures provide long-lasting protection and manage fiber optic cable for broadband delivery in outdoor applications. Provided with or without back-up batter compartment.

FEATURES

- Standard pitched roof promotes water runoff
- Available with either single- or dual-access doors on front and rear for convenient access
- Available with or without battery compartment
- 3-point latching mechanisms and padlocking handles on doors provide security
- Seamless foam-in-place gasket seals doors against moisture and dust
- Wind latch mechanisms on doors control door when open for equipment maintenance
- Removable lifting lugs [2] for easy installation
- Rack angles adjustable for 19-in. or 23-in. spacing without modifications
- Use cage nuts to mount equipment

- Cabinet top insulation helps prevent the formation of condensation and reduce solar gain inside cabinet. Cabinet side insulation is optional.
- Base of cabinet has a 5.00-in. (127-mm) high aluminum mounting plinth to allow for cable alignment
- Three pyramidal boots provided at base of cabinet for sealing various sizes of cables
- All fasteners are stainless steel to maintain professional appearance in severe outdoor climate conditions
- Grounding buss bar provided

SPECIFICATIONS

- Manufactured from Type 5052-H32 .125-in.-thick aluminum
- Seams continuously welded and ground smooth
- Heavy gauge continuous hinge

FINISH

RAL 7035 light textured low gloss polyester powder paint over pretreated surfaces. Custom finishes available please contact your local Hoffman sales office.

ACCESSORIES

Fiber Management Spool
 Compact Cooling Fans
 Temperature Control Switches
 Light Package
 Screw Packages
 Fiber Optic Cabinet Pole-Mount Kit
 Compact and Mid-Size Heat Exchangers
 Type 3R, 12, 4 T4 Line Indoor/Outdoor Air Conditioners
 Electric Heaters

BULLETIN: DTX
Standard Product FTTX Without Battery Compartment

Catalog Number	AxBxC in.	AxBxC mm	Rack Units	Description
T303020FTTX	30.00 x 30.00 x 20.00	762 x 762 x 508	10	Single-Access
T503020FTTX	50.00 x 30.00 x 20.00	1270 x 762 x 508	22	Single-Access
T303020FTTXDA	30.00 x 30.00 x 20.00	762 x 762 x 508	10	Dual-Access
T503020FTTXDA	50.00 x 30.00 x 20.00	1270 x 762 x 508	22	Dual-Access

Standard Product FTTX With Battery Compartment

Catalog Number	AxBxC in.	AxBxC mm	Rack Units	Description
T503020FTTXB	59.49 x 30.00 x 23.27	1511 x 762 x 591	22	Single
T503028FTTXDAB	59.49 x 30.00 x 34.53	1511 x 762 x 877	22	Dual

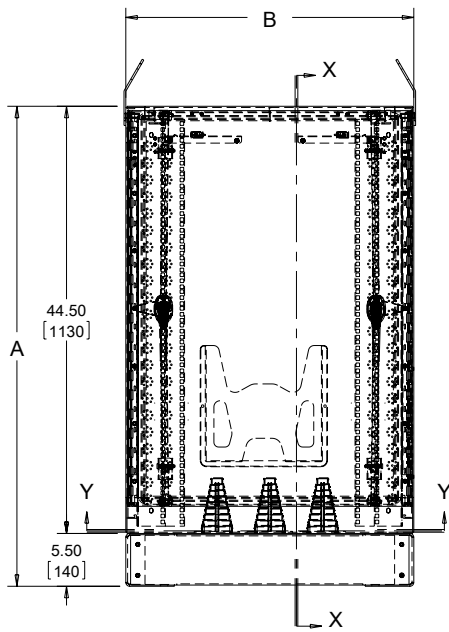

A=50
[1270]

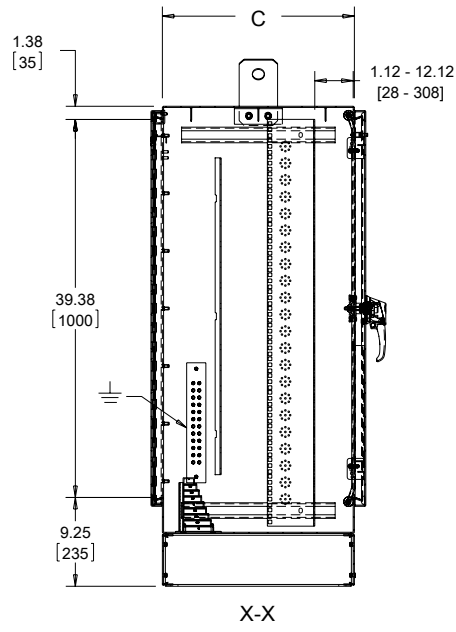

X-X

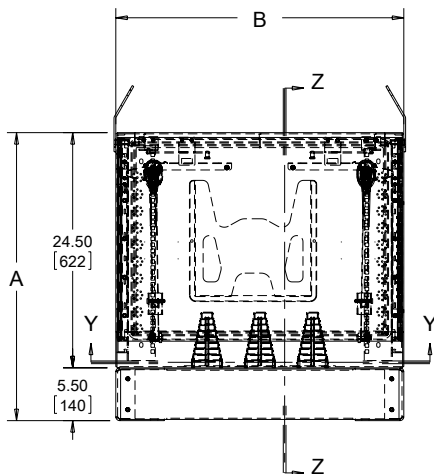

A=30
[762]

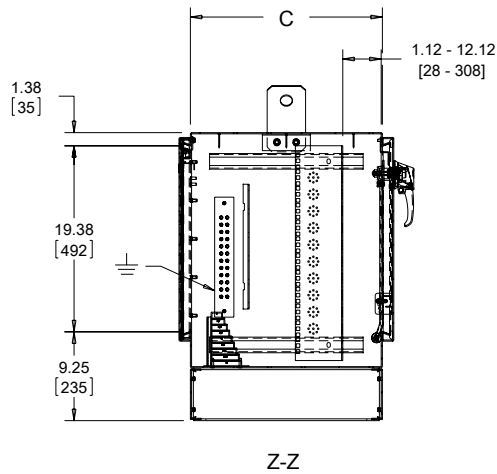

Z-Z

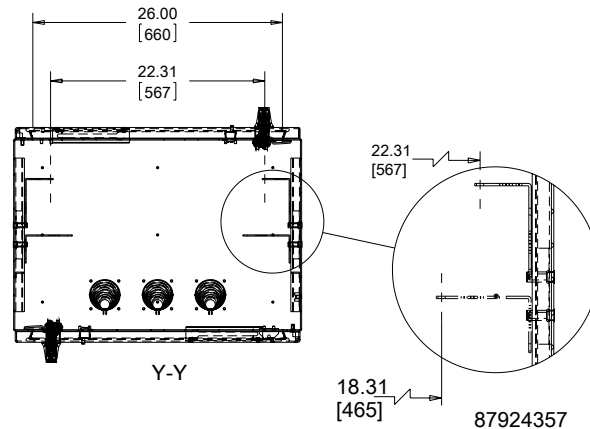
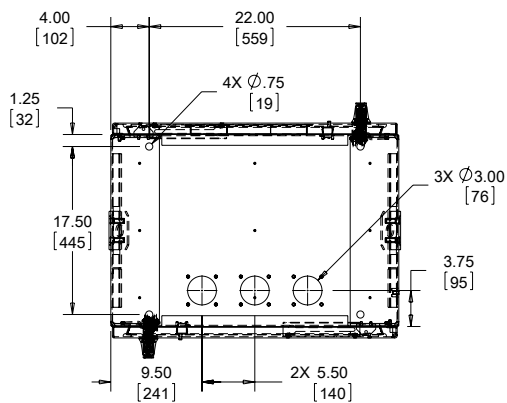

Y-Y

87924357

FIBER MANAGEMENT SPOOL



Fiber Management Spools mount inside the cabinet and help maintain proper bends when routing cable. Molded of black plastic. Includes thread-forming M5 mounting screws. Slots provided on flange for VELCRO® cable wrap.

VELCRO is a trademark of Velcro Industries B.V.

BULLETIN: DTX

Catalog Number	Radius (in.)	Radius (mm)	Pkg. Qty.
TOPTKSPL	1.18	30	4

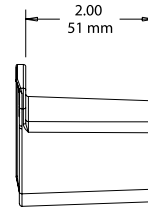

87951339

FIBER OPTIC CABINET POLE-MOUNT KIT

The Pole-Mount Kit installs on the rear of the single-access cabinets using the hardware provided. No drilling or tapping of the cabinet is required. Installation instructions are provided for mounting to various types of poles.

BULLETIN: DTX

Catalog Number	Kit Includes	Use With
T11FTXPMK	Channel and hardware for attaching to cabinet	11U Cabinet
T23FTXPMK	Channel and hardware for attaching to cabinet	23U Cabinet

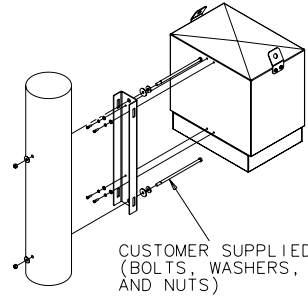

INSTALLATION ON WOOD POLE

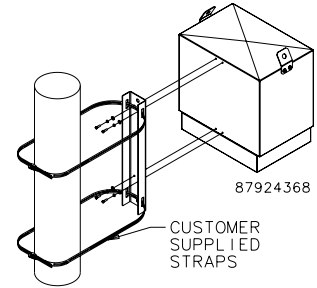

INSTALLATION ON CONCRETE OR STEEL POLE

CAGE NUT PACKAGE



Cage Nut Packages are for use with square-hole rack angles. Cage nuts are plated steel.

BULLETIN: DACCY

Catalog Number	Color	Description	Pkg. Qty.
PM5CN	Silver	M5 cage nut	20
PM6CN	Silver	M6 cage nut	20
PM6CN250	Silver	M6 cage nut	250
P1032CN	Silver	10-32 cage nut	20
P1032CN250	Silver	10-32 cage nut	250
P1224CN	Silver	12-24 cage nut	20
P1224CN250	Silver	12-24 cage nut	250

SCREW PACKAGE



Screws attach rack panels and rack-mounted equipment to rack-mounting angles.

BULLETIN: A80, DACCY, X20

Catalog Number	Color	Description	Pkg. Qty.
ES1224	Silver	12-24 x 5/8 in. combo head	20
ES1224250	Silver	12-24 x 5/8 in. combo head	250
ES1224B	Black	12-24 x 5/8 in. combo head	20
ES1224B250	Black	12-24 x 5/8 in. combo head	250
ASM5	Silver	M5 x 20 mm Combo Head	20
ASM6	Silver	M6 x 16 mm combo head	20
ASM5T	Silver	M5 x 12 mm thread-forming Phillips hex head screws	20
ASM6250	Silver	M6 x 16 mm combo head	250
AS1032	Silver	10-32 x 5/8 in. combo head	20
AS1032250	Silver	10-32 x 5/8 in. combo head	250
AS1032B	Black	10-32 x 5/8 in. combo head	20

Use ASM5T on PROLINE™ frame or Net Series extruded holes.

TOP SOLAR SHIELD FOR CABINET

The Top Solar Shield provides reduction to solar load by providing air insulation to the top of the cabinet. Shield top surface is angled to direct rain water off to the side of the cabinet. The solar shield bolts on to cabinet for easy assembly. Made of 0.80 aluminum with cabinet matching RAI 7035 finish

BULLETIN: DTX

Catalog Number	AxBxC in.	AxBxC mm	Use with B x C
TSS3020	1.73 x 30.20 x 21.26	44 x 767 x 540	Single Access
TSS3020D	1.73 x 30.20 x 22.36	44 x 767 x 568	Dual Access
TSS3028D	1.73 x 30.20 x 30.39	44 x 767 x 772	Dual Access

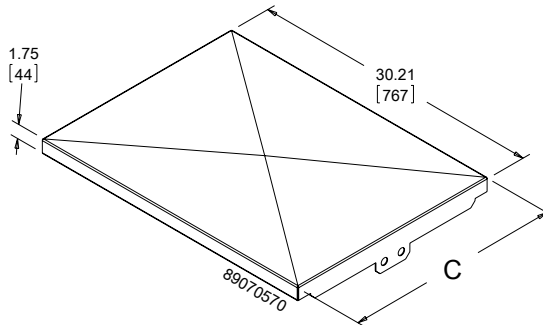

Notes