

**BRA!N BOXES**



**PCMCIA 1 PORT RS422/485**

**1.2 EDITION OCTOBER 1999**

## **Guarantee.**

### **FULL 36 MONTHS GUARANTEE.**

We guarantee your interface card for a full 36 months from purchase, parts and labour, provided it has been used in the specified manner. In the unlikely event of failure return your interface to your Dealer, with proof of purchase, who will determine whether to repair or replace this product with an equivalent unit.

## **COPYRIGHT.**

### **COPYRIGHT © 1985-1999.**

All rights reserved. No part of this hardware, circuitry or manual may be duplicated, copied, transmitted or reproduced in any way without the prior written consent of the Manufacturer.

Due to the Manufacturers commitment to quality, software is subject to continuous improvements: information regarding upgrades can be obtained from your supplier.

supplied to you by:

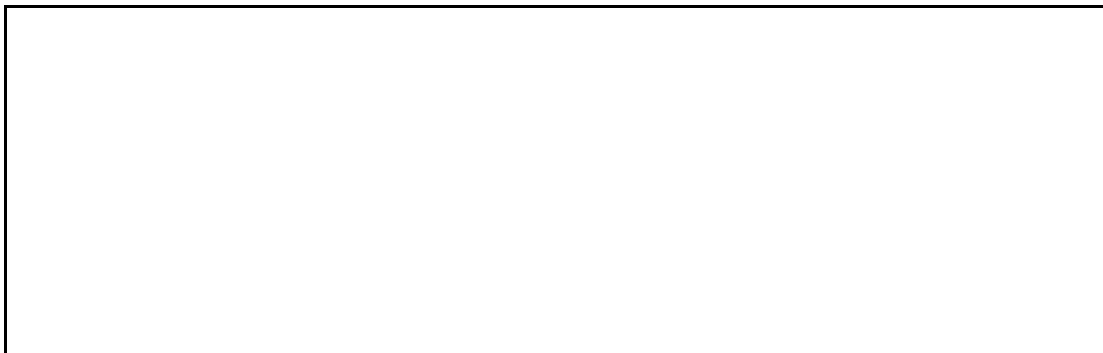

## **ACKNOWLEDGEMENTS.**

IBM, COMPAQ, Hewlett Packard, H.P. and EPSON are trademarks of the relevant companies. Windows is a trademark of Microsoft.

**The Layout Of This Manual**

**THE LAYOUT OF THIS MANUAL**

**Chapter 1 - Hardware Configuration**, Summarises the features of the **PCMCIA 1 Port RS422/485 Card**.

**Chapter 2 – Installing the card into the PC**, Explains how to insert a new PCMCIA card

**Chapter 3 –Software Installation**

This chapter details how to install and configure the **PCMCIA 1 Port RS422/485 Card in Windows 95, Windows 98 and Windows 2000**.

**Chapter 4 – Additional RS422/485 Operation**

**Table Of Contents.**

**CHAPTER 4 – ADDITIONAL RS422/485 OPERATION .....2**

**CHAPTER 1 HARDWARE GUIDE .....5**

    Introduction.....5

    PCMCIA 1 Port RS422/485 Card Features. ....5

    Configuring PCMCIA Cards. ....5

**CHAPTER 2 INSTALLING IN YOUR COMPUTER.....6**

**CHAPTER 3 SOFTWARE INSTALLATION.....7**

    Introduction.....7

    Windows 95 Installation .....7

        Windows 95 CD ROM Installation Procedure .....8

        Windows 95 Floppy Disk Installation Procedure .....10

    Windows 98 and Windows Millennium Installation .....11

        Windows 98 CD ROM Installation Procedure .....12

        Windows 98 Floppy Installation Procedure.....14

    PCMCIA Card Setup in Windows 95, Windows 98 and Windows Millennium .....16

    PCMCIA Port Setup in Windows 95, Windows 98 and Windows Millennium .....17

    Windows 2000 Installation .....21

        Windows 2000 CD ROM Installation Procedure .....22

        Windows 2000 Floppy Installation Procedure.....25

    PCMCIA Port Setup in Windows 2000 .....27

    Windows NT4 Installation.....29

    Windows CE Installation .....32

**CHAPTER 4 ADDITIONAL RS422/485 OPERATION .....35**

    The RS422 Standard. ....35

    The RS485 Standard. ....35

    Terminating Impedance's. ....36

    Fail Safe Open Circuit Detection. ....36

    Fail Safe Short Circuit Protection. ....37

    RS422 Operation.....37

<b>PCMCIA 1 Port RS422/485</b>	<b>Introduction</b>
RS422 Serial Port Cables.....	38
RS485 Operation.....	39
RS485 Cable. ....	39
RS485 One Talker - Many Listeners, Half Duplex. ....	40
RS485 Many Talkers- Many Listeners, Half Duplex. ....	41
RS485 Many Talkers- Many Listeners, Full Duplex.....	41
Optional Grounding Arrangements.....	43
<b>INDEX.....</b>	<b>46</b>

# CHAPTER 1

## HARDWARE GUIDE

### Introduction.

This chapter details the specifications of the PCMCIA 1 Port RS422/485 Serial card.

### PCMCIA RS422/485 Card Features.

- \* Reliable communications up to 1KM!
- \* 100% 16C550 PC Compatible serial port, up to 1 Megabaud.  
16950 Compatible FIFO provides 128-byte input and 128-byte output buffer on each port.
- \* Full modem control TX RX RTS CTS and GND signals.
- \* Fully double buffered for reliable asynchronous operation.  
High speed integrated circuitry ensures operation with fast PC's e.g. 650 MHz Pentium III.
- \* Fully Plug and Play.

Dimensions: 2 x 3.3 in, 85x55 mm

I/O Connection: Serial Port : 9 pin Male D type.

Weight: 16g

### Configuring PCMCIA Cards.

PCMCIA cards, by definition, require no hardware configuration and can be installed "directly from the box".

## CHAPTER 2 INSTALLING IN YOUR COMPUTER



This card is 'hot plug' compatible it may be inserted into your pcmcia type 2 slot when the machine is either off or powered on. Please refer to your machine user guide for detailed instructions on inserting a PC card.

## CHAPTER 3

# SOFTWARE INSTALLATION

### Introduction.

This section describes the software installation procedure allowing the PCMCIA 1 port RS422/485 to be configured within the Windows 95 and Windows 98/Millennium operating systems.

### Windows 95 Installation

- Insert the card into an available type2 socket. This can be done even if the machine is powered ON.
- If installing from a "power off" condition Windows 95 should then load normally. During the booting process, Windows 95 will detect the card and briefly display a message box indicating the detection process.



- Windows will then display the "Update Device Driver Wizard", requesting "insert any disk which came with the card". Insert the Serial Solutions CDROM installation disk or the Serial Solutions floppy disk into an appropriate drive and click 'Next' .



## Windows 95 CD ROM Installation Procedure



Click **Other Locations**



Type <drive>:\disking\sswin9x substituting the letter of your CD ROM drive for <drive>

Click OK

## PCMCIA 1 Port RS422/485

## Software Installation



Click Finish



Click OK

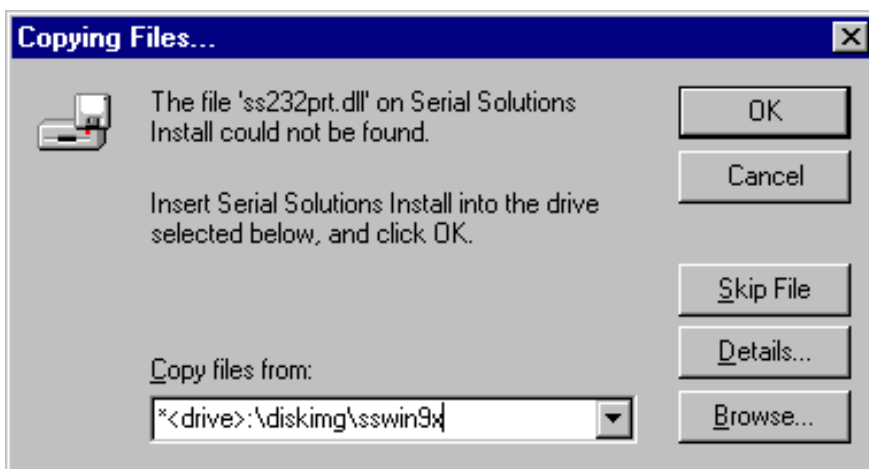

Type \*<drive>:\diskimg\sswin9x substituting the letter of your CD ROM drive for <drive>

Click OK

## Windows 95 Floppy Disk Installation Procedure



Click Finish

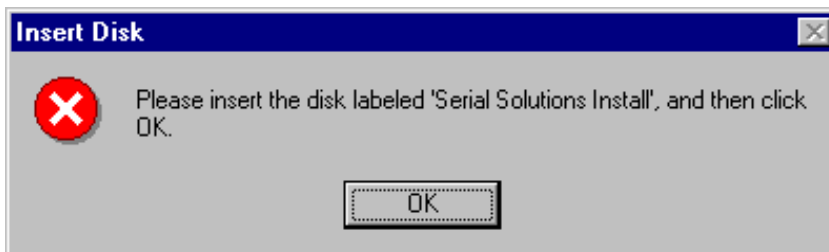

Click OK

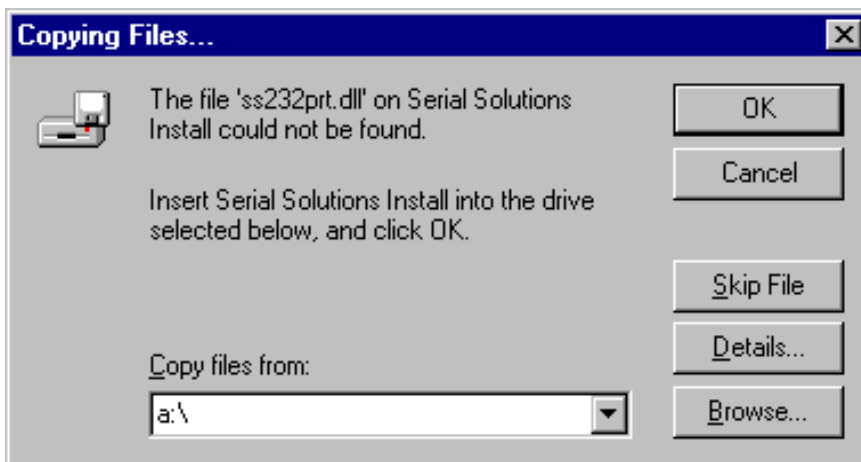

Type a:\

Click OK

## Windows 98 and Windows Millennium Installation

- Windows Millennium Installation follows the same procedure as Windows 98 Installation.
- Insert the card into an available type2 socket. This can be done even if the machine is powered ON.
- If installing from a "power off" condition Windows 98 should then load normally. During the booting process, Windows 98 will detect the card and briefly display a message box indicating the detection process.



- Windows will then display the "Update Device Driver Wizard", requesting "insert any disk which came with the card". Insert the Serial Solutions CDRom installation disk or the Serial Solutions floppy disk into an appropriate drive and click 'Next' .

## Windows 98 CD ROM Installation Procedure

Choose the “Search for the best driver for your device”



Click Next

Select Specify a location



Type `<Drive>:\disking\sswin9x\`

Where `<Drive>` is the letter of your CDROM Drive

Click Next

## PCMCIA 1 Port RS422/485

## Software Installation



Click **Next**



Click **Finish**

## Windows 98 Floppy Installation Procedure

Choose the “Search for the best driver for your device”



Click Next



Select Floppy disk drives

Click next

## PCMCIA 1 Port RS422/485

## Software Installation



Click next



Click Finish



## PCMCIA Card Setup in Windows 95, Windows 98 and Windows Millennium

Right Click **My Computer** -> **Properties** on the desktop

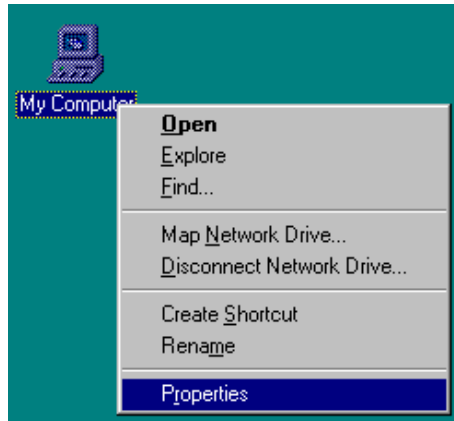

Click on the Device Manager tab

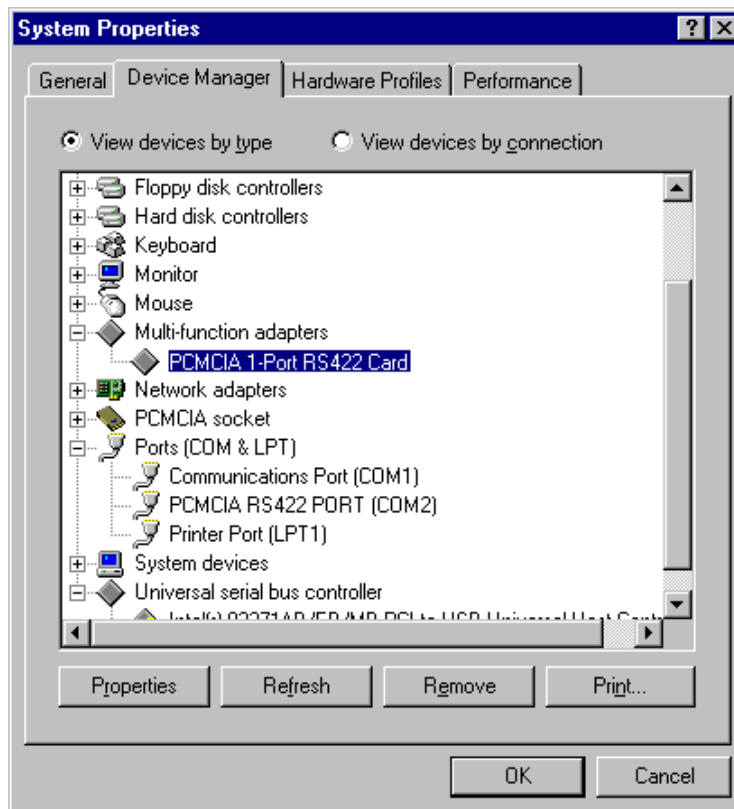

Under Multi-function adapters double-click on PCMCIA 1 Port 422 Card

## PCMCIA 1 Port RS422/485

## Software Installation

Click on the Serial Solutions tab

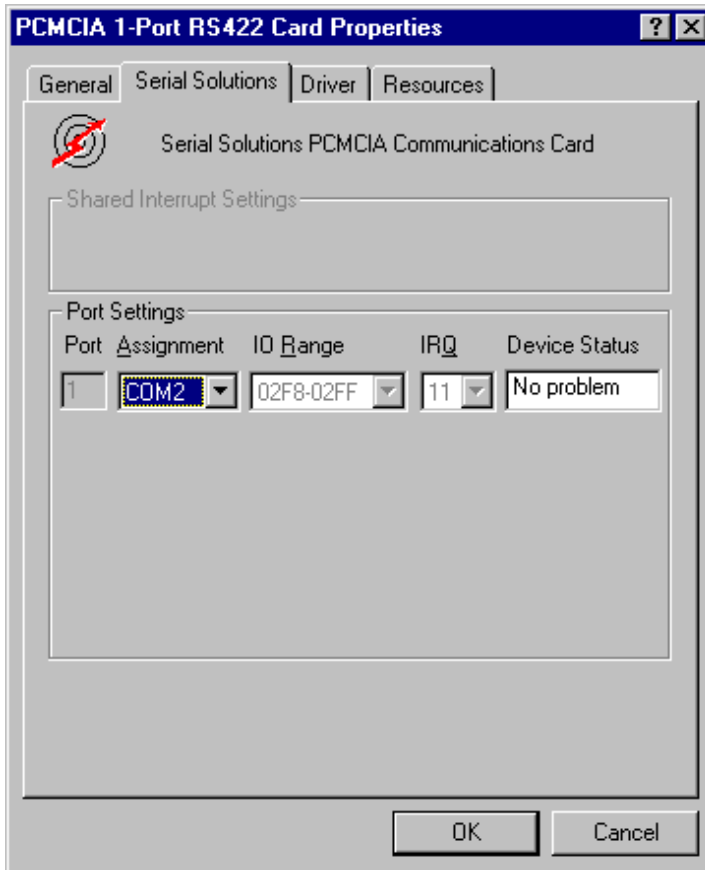

The Serial Solutions tab allows modification of any user controlled features for the card

## PCMCIA Port Setup in Windows 95, Windows 98 and Windows Millennium

Right Click **My Computer** -> **Properties** on the desktop

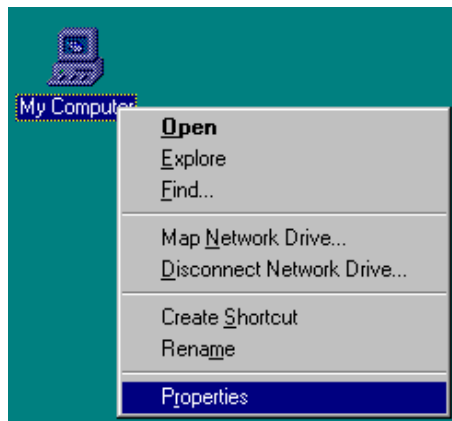

# PCMCIA 1 Port RS422/485

# Software Installation

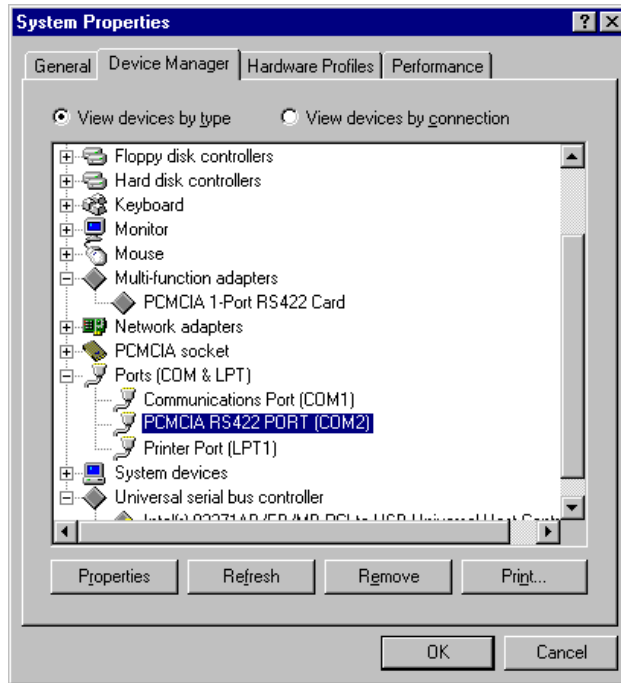

Under Ports (COM &LPT) double-click on PCMCIA RS422 PORT (COM\*)  
\*is the number allocated to the port.

Click on the Port Settings tab

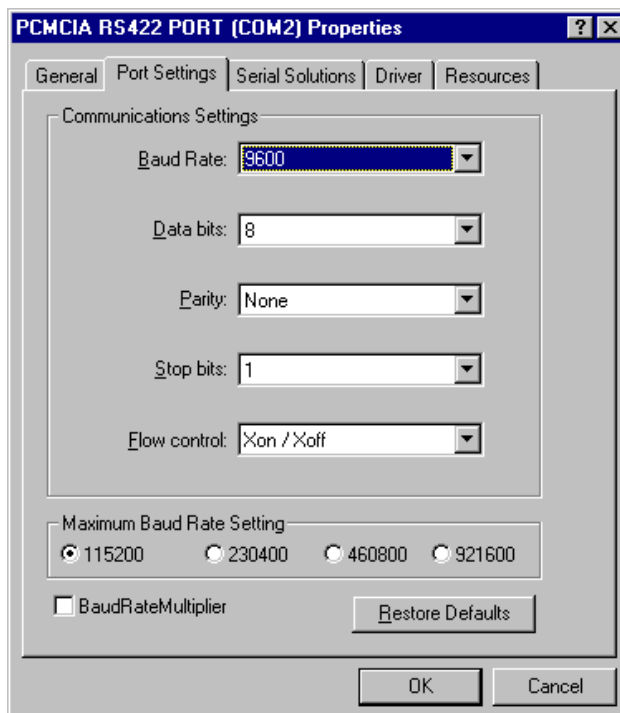

Settings available in this window are:

**Baud Rate.**  
**Data Bits.**  
**Parity.**  
**Stop Bits.**  
**Flow Control.**



Change to suit remote device.

**Restore Defaults** - When clicked, this will reset the selected port to the default values of:

Baud Rate:	9600
Data Bits:	8
Parity:	None
Stop Bits:	1
Flow Control:	Xon / Xoff

### Maximum Baud Rate Setting

These settings allow access to the faster data rates available on this card. The faster rates are not enabled by default for compatibility purposes. The faster data rates are only available directly from your application if it uses the standard Windows dialogue for serial port settings.

### Baud Rate Multiplier

This enables applications that do not use the standard Windows serial port configuration dialogue to access the faster data rates. e.g. with this option enabled, an application which selects 115,200 baud will actually set the hardware to the fastest possible rate of 921,600 baud. In other words the baud rate is multiplied by a factor of 8.

## PCMCIA 1 Port RS422/485

## Software Installation

Click on the Serial Solutions tab.

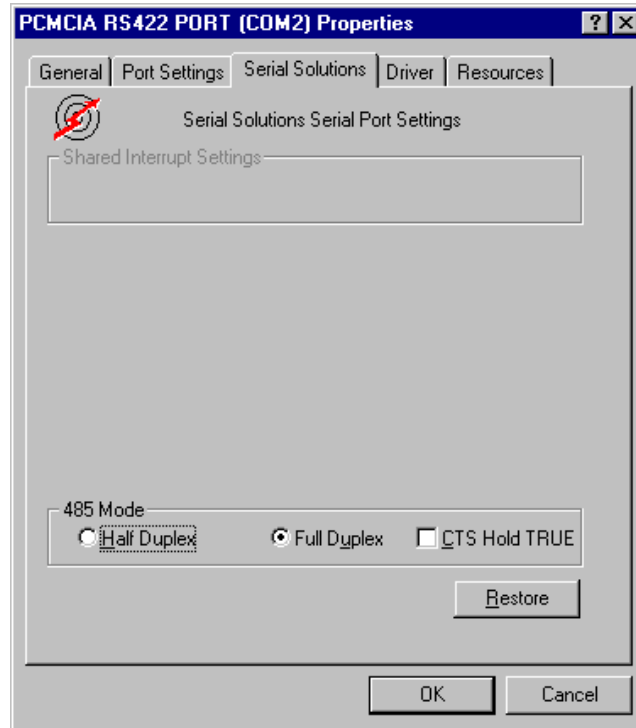

Settings available in this window are

485 mode. - This option enables the card to be switched into full or half duplex (2 or 4 wire) mode.

Please note that the supplied cable requires modification for 2 way communication in half duplex mode.

### Windows 2000 Installation

- Insert the card into an available type2 socket. This can be done even if the machine is powered ON.
- If installing from a "power off" condition Windows 2000 should then load normally. During the booting process, Windows 2000 will detect the card and briefly display a message box indicating the detection process.



- Windows will then display the "Found New Hardware Wizard", requesting "insert any disk which came with the card". Insert the Serial Solutions CDROM installation disk **or** the Serial Solutions floppy disk into an appropriate drive and click 'Next' .

## PCMCIA 1 Port RS422/485

## Software Installation



Select "Search for a suitable driver for my device"  
Click Next

## Windows 2000 CD ROM Installation Procedure

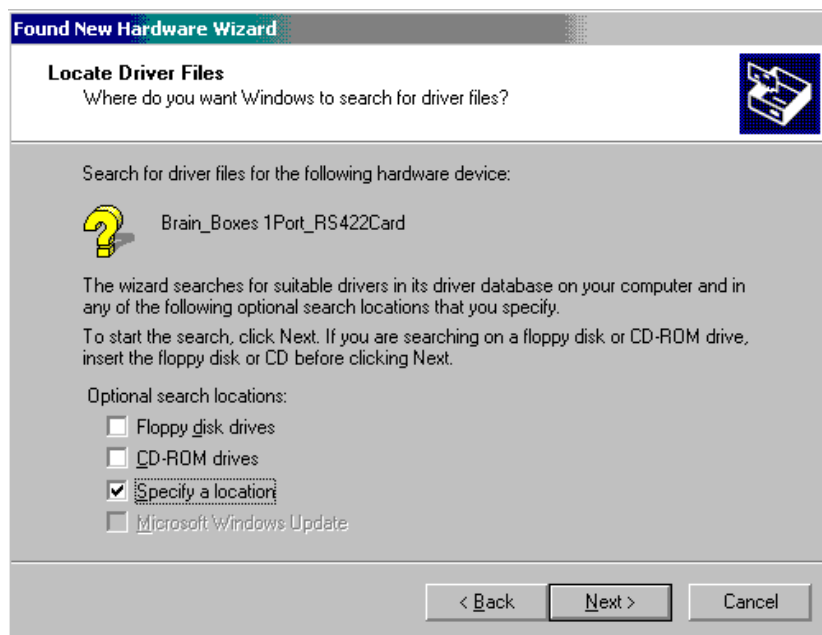

Select Specify a location  
Click Next

## PCMCIA 1 Port RS422/485

## Software Installation

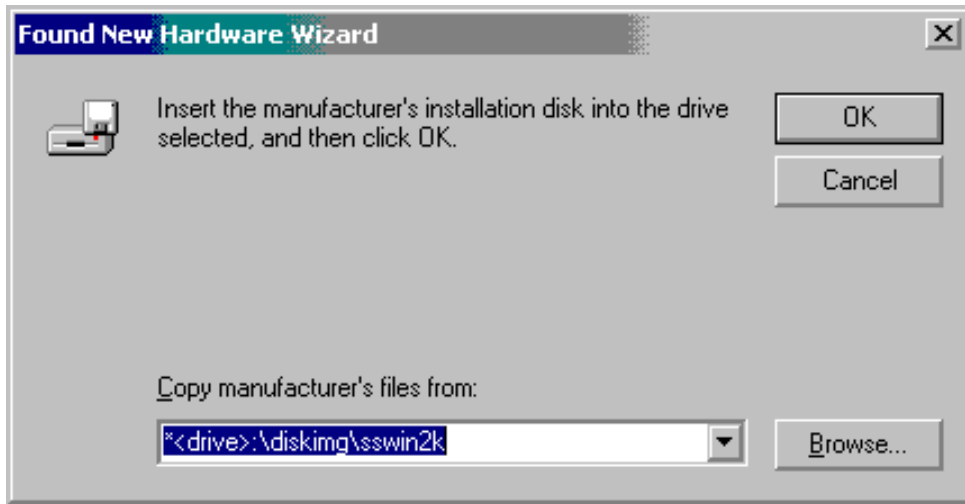

Type **<Drive>:\diskimg\sswin2k\**

Where **<Drive>** is the letter of your CDROM Drive

Click OK

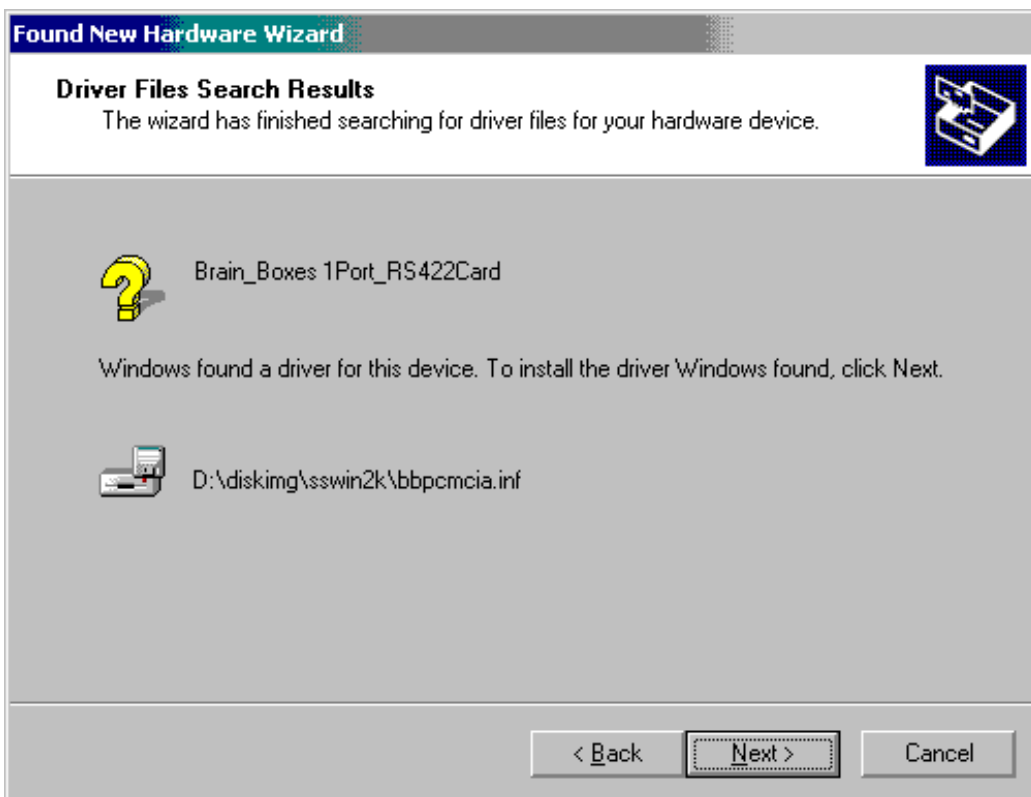

Click Next



## PCMCIA 1 Port RS422/485

## Software Installation

Please note, at the time of creation of this document, Windows2000 is still in BETA, and it is not possible to get drivers signed by Microsoft.  
Brain Boxes fully intend to have obtained a driver signature for this product shortly after the operating system is available on general release.

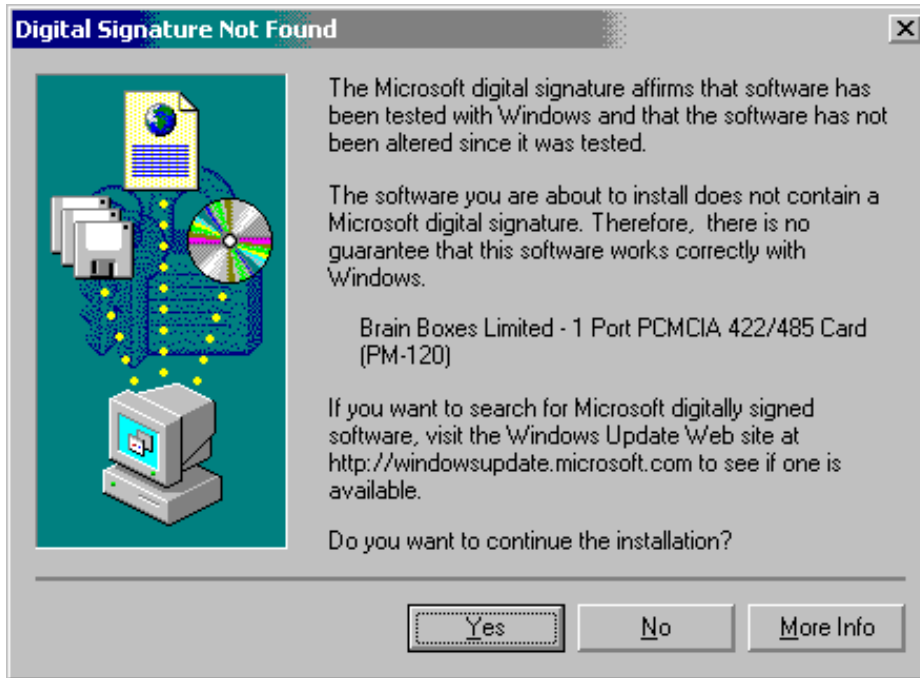

Click Yes



Click Finish

## Windows 2000 Floppy Installation Procedure

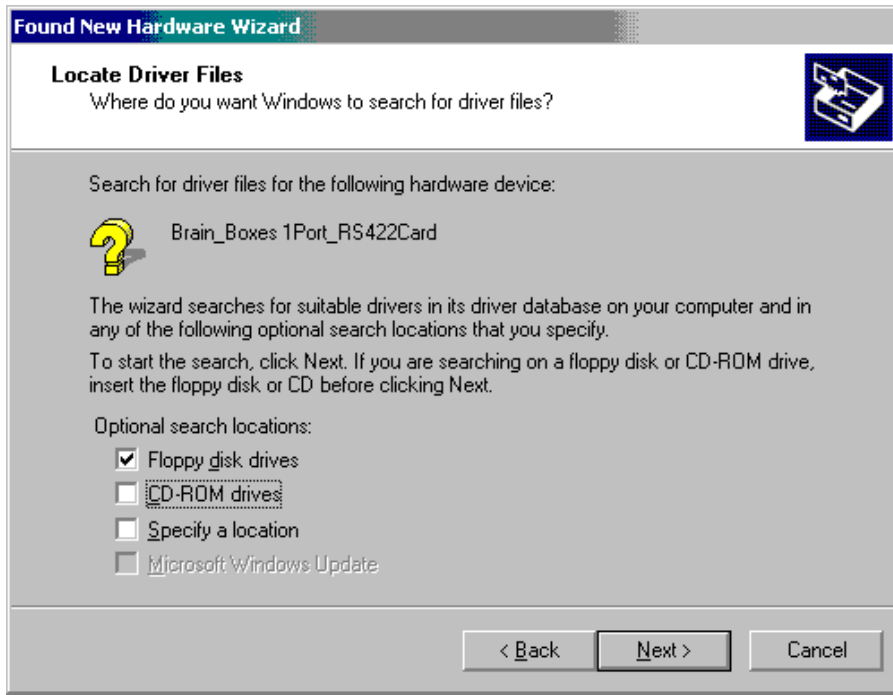

Select Floppy disk drives

Click next

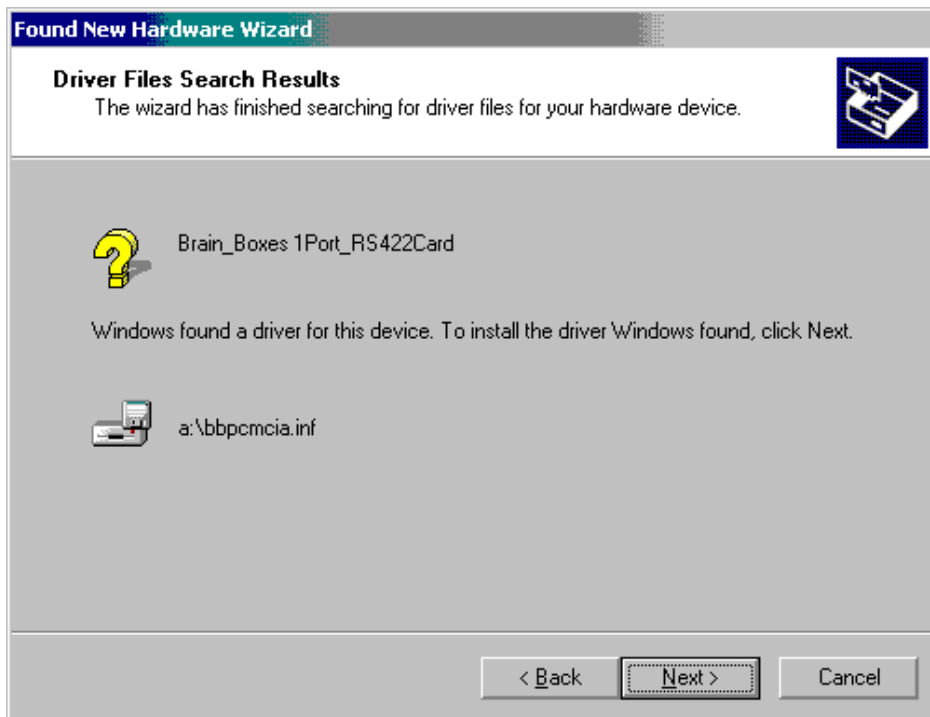

Click Next

## PCMCIA 1 Port RS422/485

## Software Installation

Please note, at the time of creation of this document, Windows2000 is still in BETA, and it is not possible to get drivers signed by Microsoft.  
Brain Boxes fully intend to have obtained a driver signature for this product shortly after the operating system is available on general release.

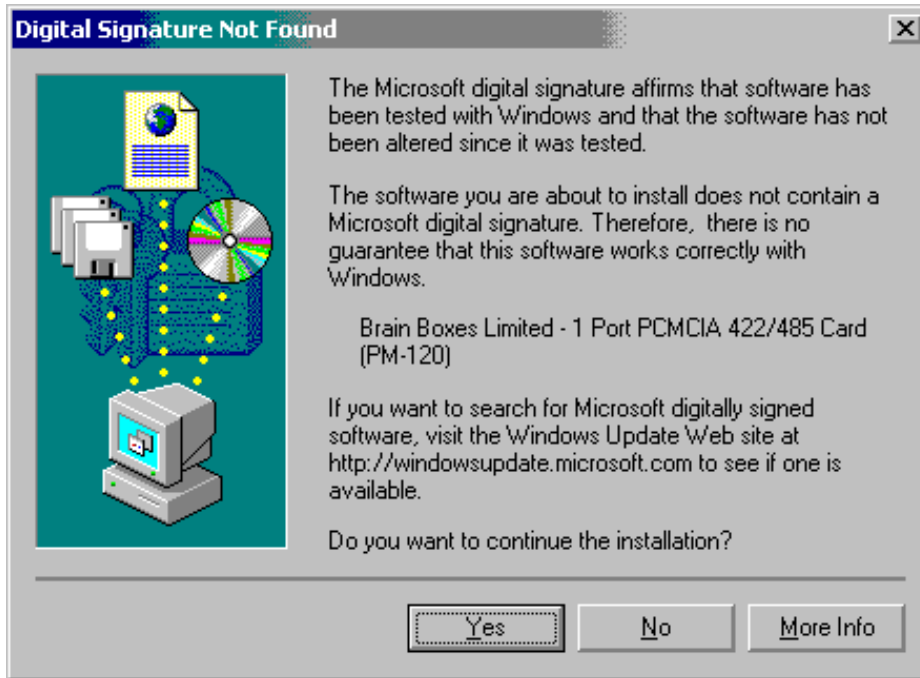

Click Yes

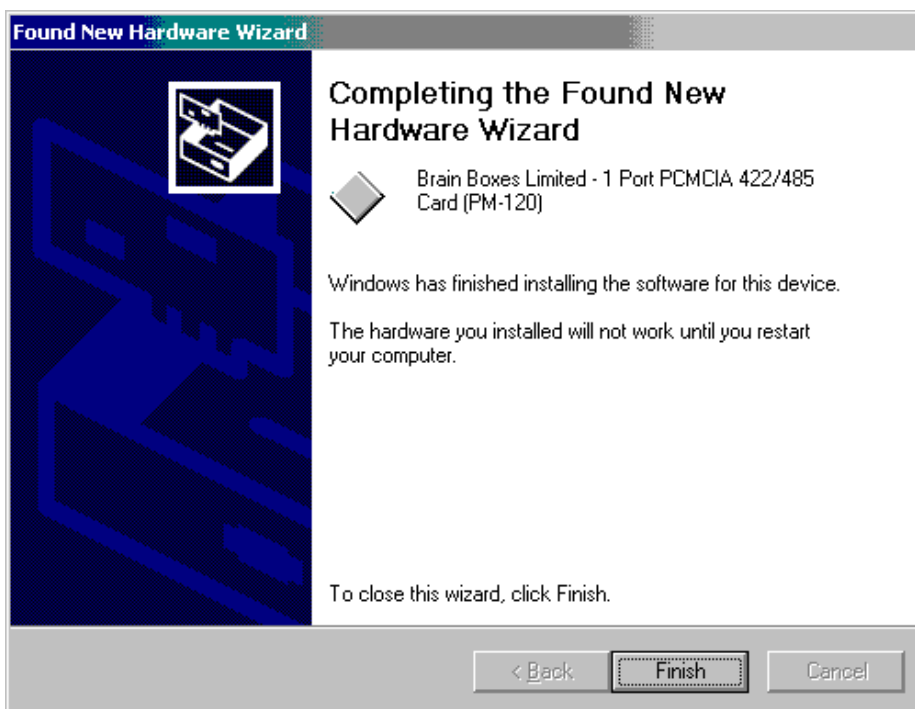

Click Finish

## PCMCIA Port Setup in Windows 2000

Right Click My Computer -> Properties on the desktop

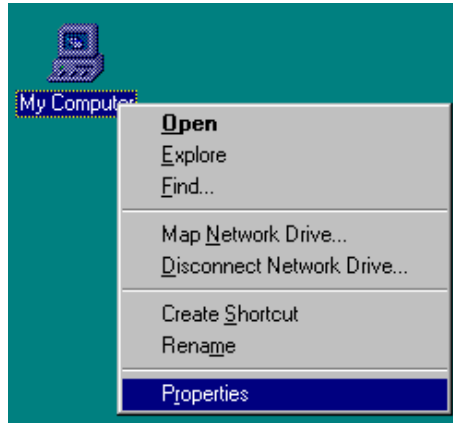

Select the Hardware Tab

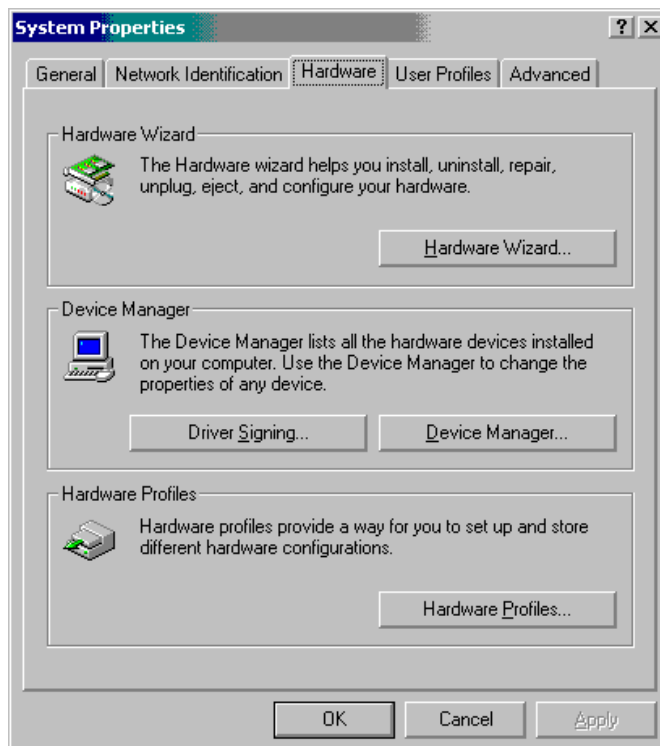

Click Device Manager

## PCMCIA 1 Port RS422/485

## Software Installation

Click on Ports (COM & LPT)

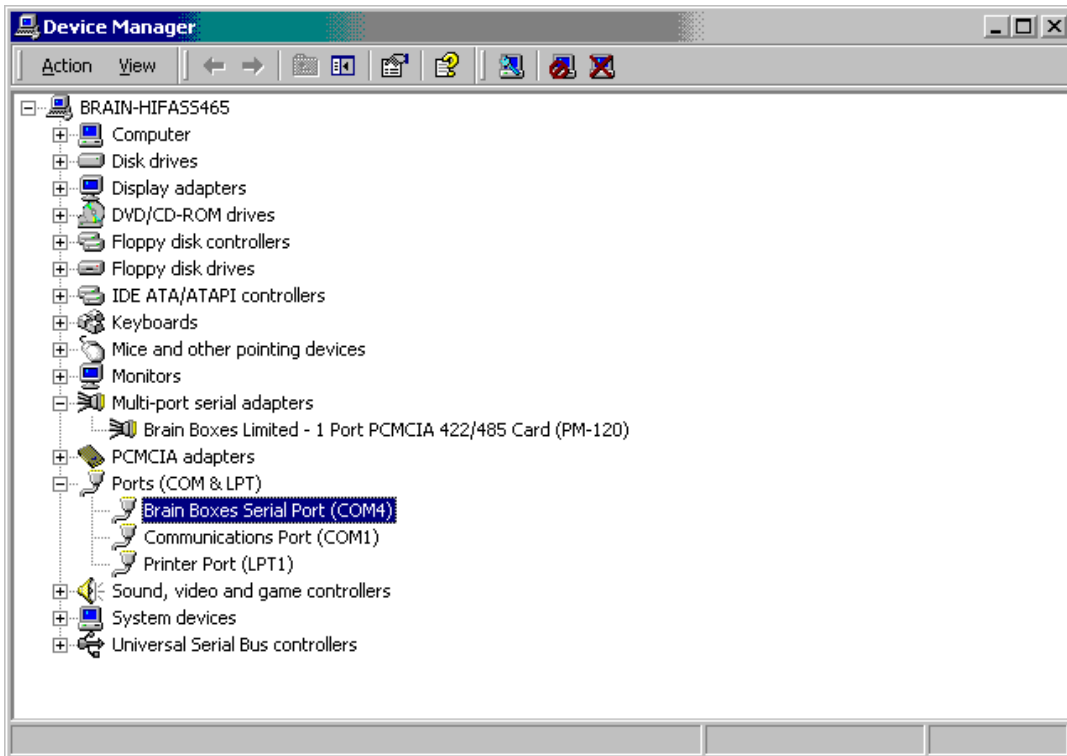

Double Click on Brain Boxes Serial Port

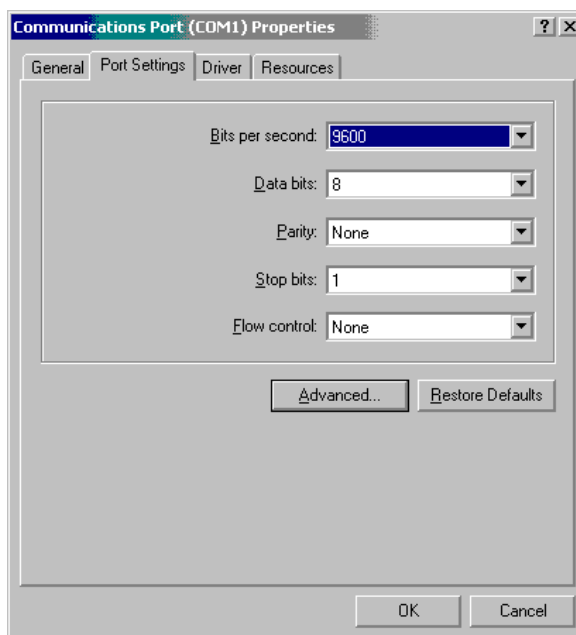

Select the Port Settings Tab  
Click on Advanced

## PCMCIA 1 Port RS422/485

## Software Installation

From this Screen COM port allocations can be changed

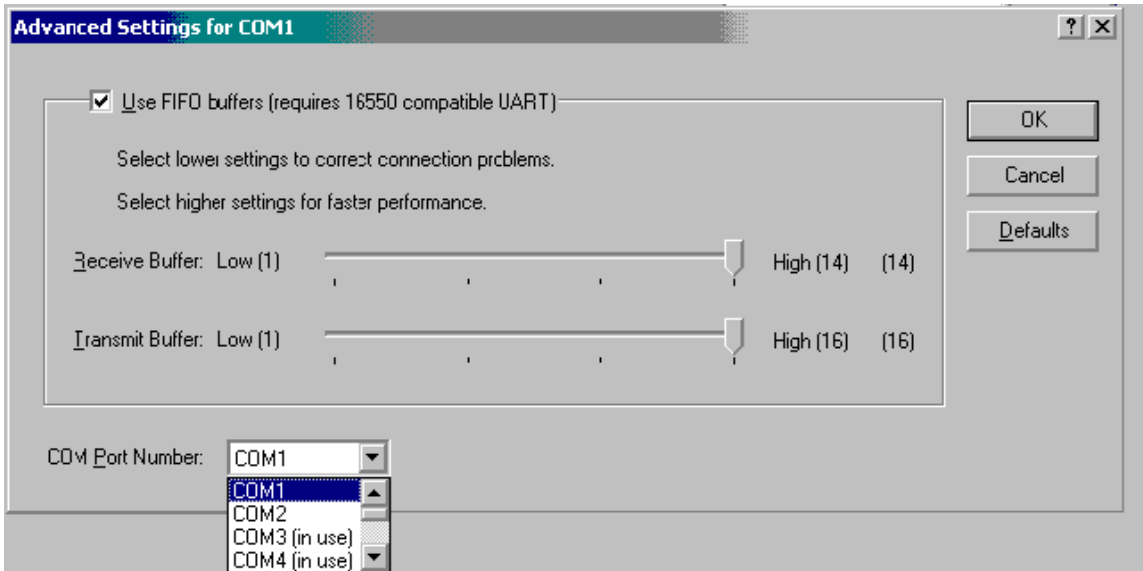

## Windows NT4 Installation

Though the PCMCIA 1 Port RS422/485 card can be used in Windows NT4 it is not yet available as a hot-pluggable card . Also not available is the half duplexing option.

Before inserting the card

Click on Start => Settings => Control Panel

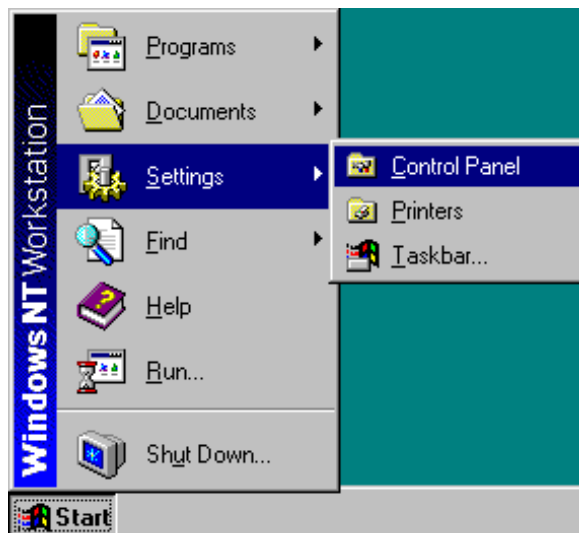

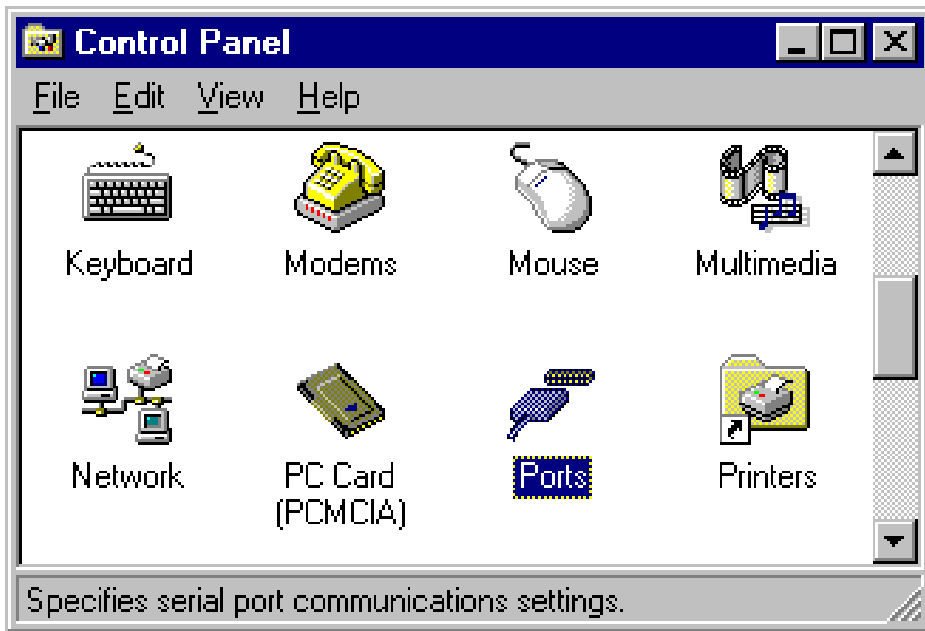

Double Click on the Ports Icon.

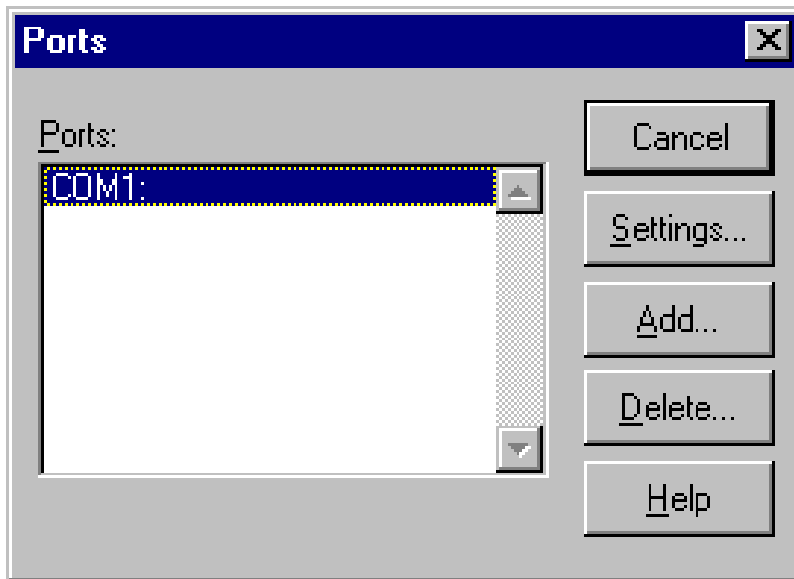

Note the COM Ports Listed  
Click Cancel.

Power down your computer  
Insert the PCMCIA Card.  
Power up your computer.

## PCMCIA 1 Port RS422/485

## Software Installation

Click on Start => Settings => Control Panel

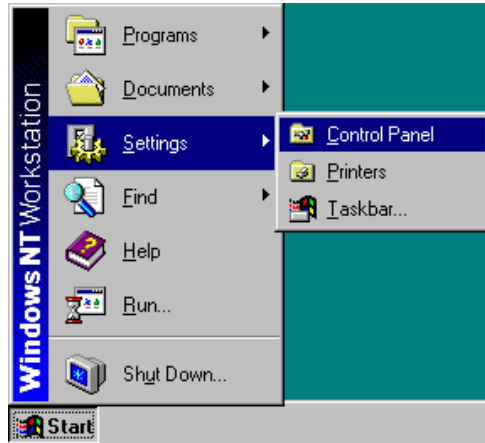

Double Click on the Ports Icon.

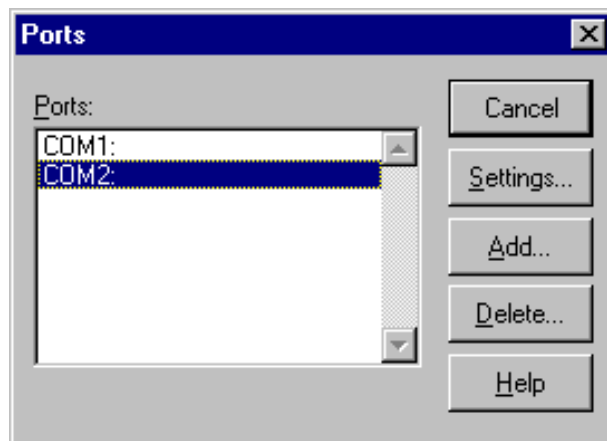
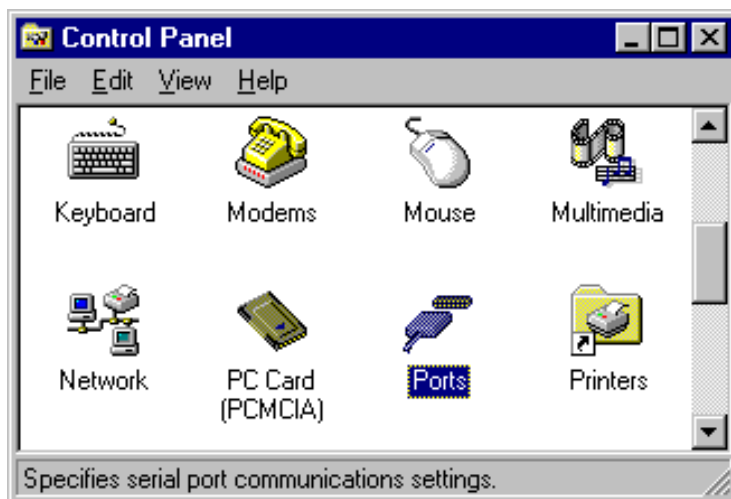

The New port listed (in this case COM2 will be the PCMCIA card port).



## Windows CE Installation

Place card in socket

Select Start

Programs

Communications

Remote Networking

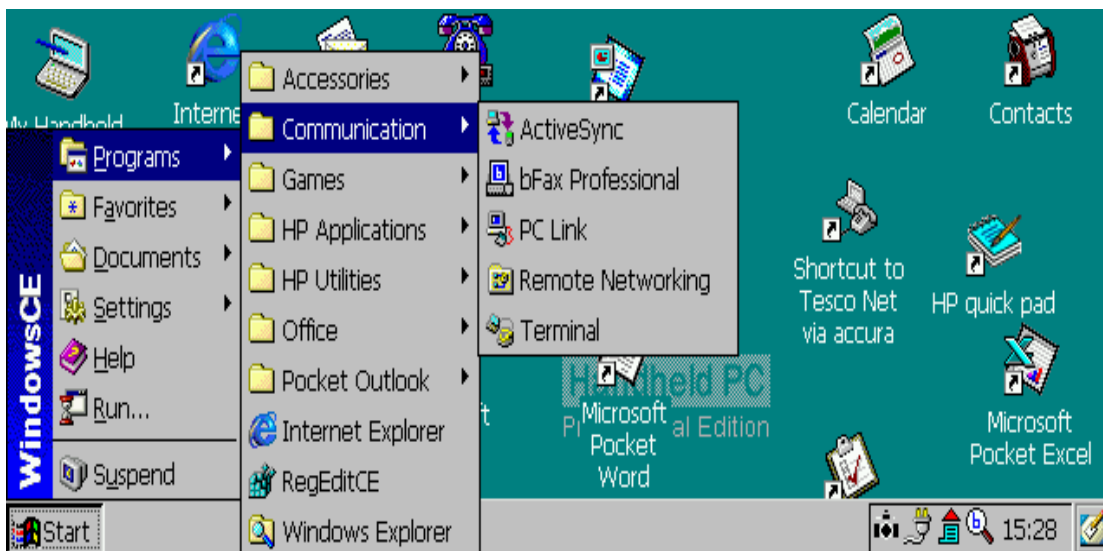

Select: " Make New Connection ", with your pen

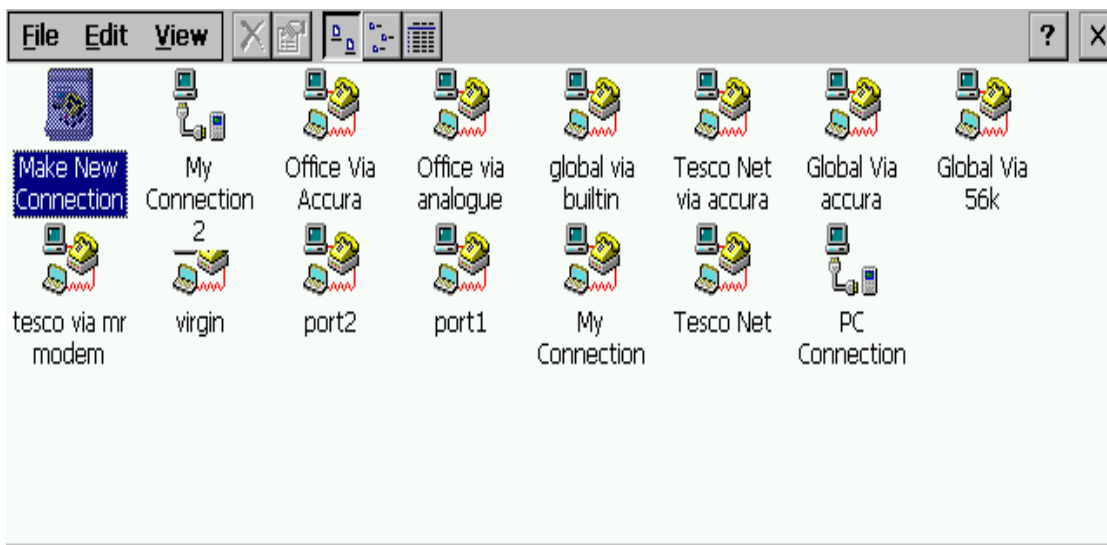

## PCMCIA 1 Port RS422/485 Additional 422/485 Operation

Type a name for the connection in the field under "Type a name for the connection"

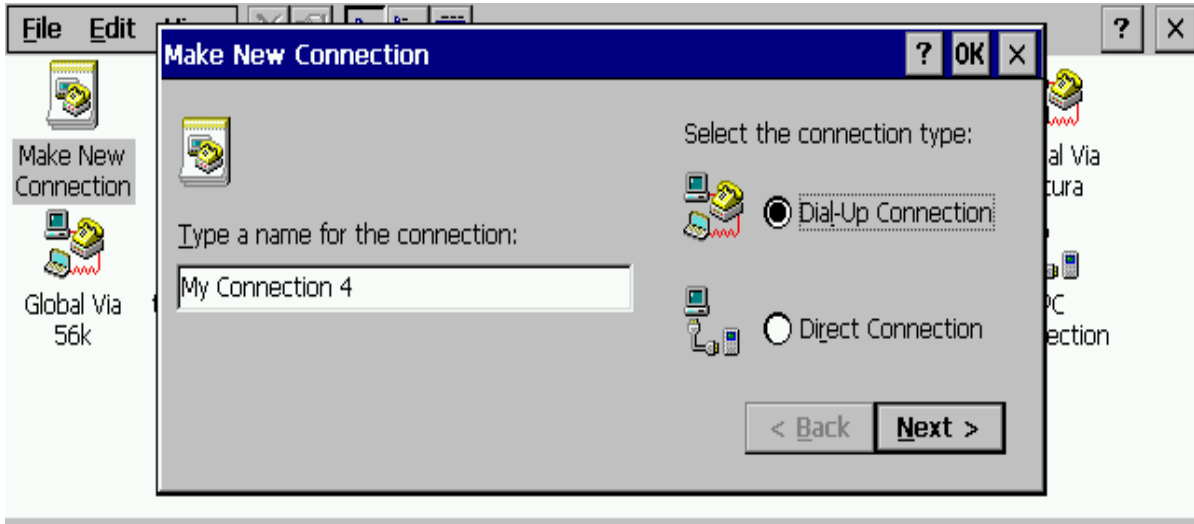

Select "Dial up Connection" Radio button  
Select Next>"

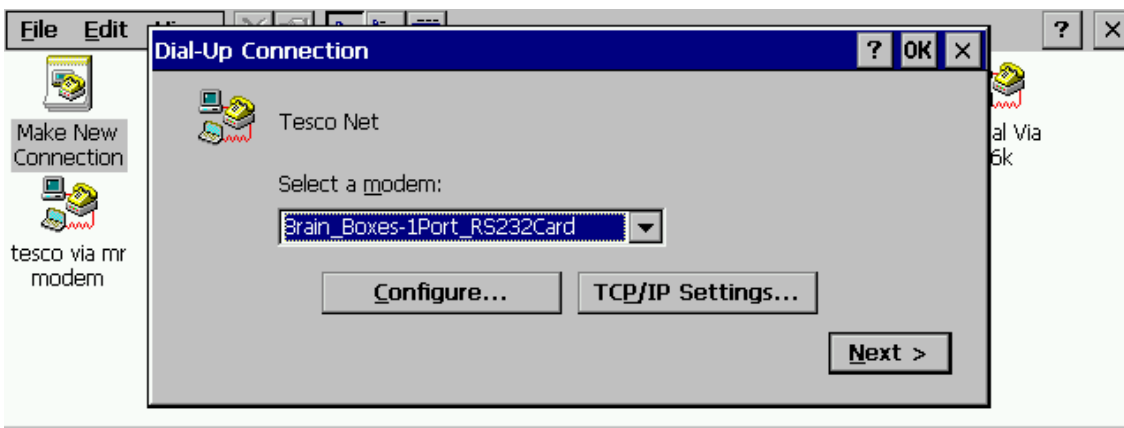

The Dialog shows a modem Icon with the name from the previous screen

There is a drop down dialog underneath "Select a Modem"  
Select

Brain\_Boxes-1port\_RS422/485 Card

## PCMCIA 1 Port RS422/485

## Additional 422/485 Operation

Select configure Button

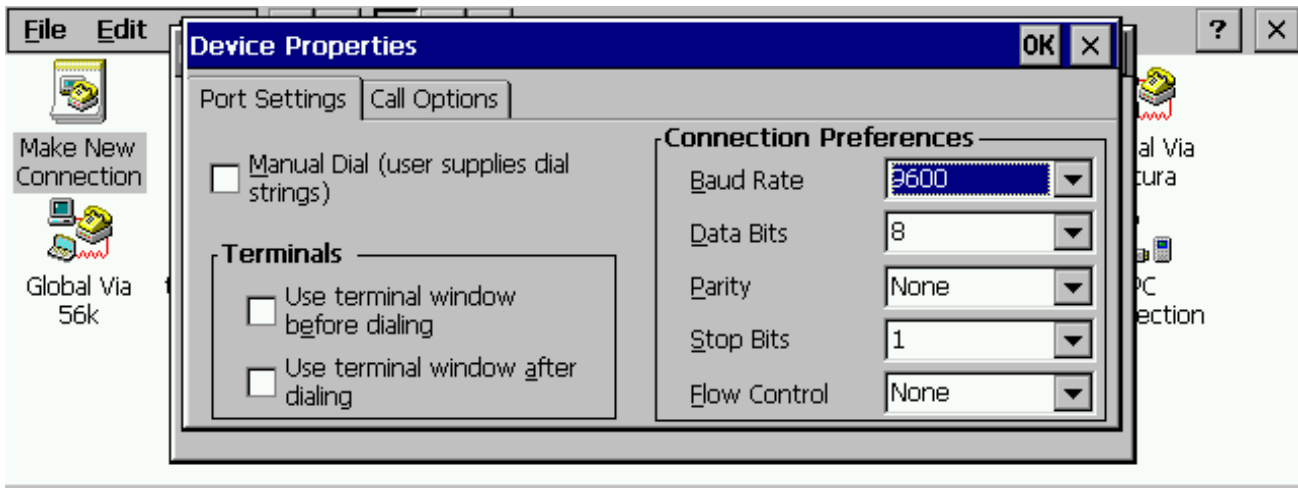

Device properties

set the following

Baud Rate	9600
Data Bits	8
Parity	None
Stop Bits	1
Flow Control	None

# CHAPTER 4 ADDITIONAL RS422/485 OPERATION

## The RS422 Standard.

The RS422 standard defines a serial communications standard. RS422 is a high speed and/or long distance data transmission. Each signal is carried by a pair of wires and is thus a differential data transmission system. Over distances up to 40 feet the maximum data rate is 10 Megabits per second, and for distances up to 4000 feet the maximum data rate is 100 Kilobytes per second. A 120-Ohm resistor should be used to terminate the receiving end of the line. It is generally used between one transmitter receiver pair to ONLY one other transmitter receiver pair, but each output can drive up to 10 receivers.

RS422 Standard	
1 Driver up to 10 Receivers	
Line Length	Max Data Rate
40 Feet = 12m	10 Mbits/sec
400 Feet = 122m	1 Mbits/sec
4000 Feet = 1219m	100 Kbits/sec

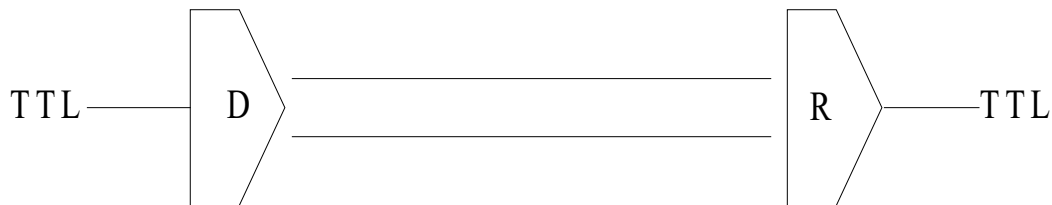

## The RS485 Standard.

The RS485 standard is similar to the RS422 standard upon which it is based. The main difference is that up to 32 transmitter receiver pairs may be present on the line at one time. A 120-Ohm resistor should be used to terminate either end of the main line. If more than one device may transmit data, the RTS line is used as

transmit enable signal, so preventing contention between talkers.

RS485 Standard	
Up to 32 Driver/Receiver Pairs	
Line Length	Max Data Rate
40 Feet = 12m	10 Mbits/sec
400 Feet = 122m	1 Mbits/sec
4000 Feet = 1219m	100 Kbits/sec

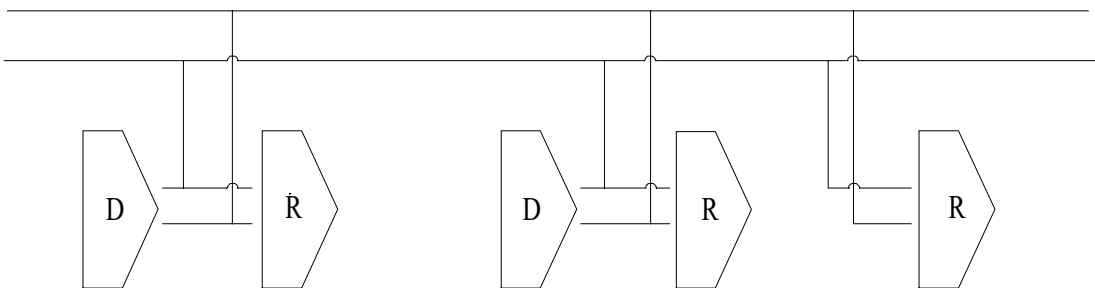

**Terminating Impedance’s.**

RS422 and RS485 lines should be terminated at the end of the main branch of the RECEIVER, in the cables characteristic impedance. These terminating impedance’s stop echoes caused by the serial data being reflected back at the cable ends. It is not necessary to terminate the transmitter end of the twisted pair.

The AT Dual Port RS422/485, Opto Isolated AT Dual Port RS422/485 and AT Velocity RS422/485 cards have the correct 120 Ohm (nominal) terminating resistors for the RXD twisted pair line and the CTS twisted pair line fitted on the RS422/485 card for both the serial ports on the card.

**There is no need to add any more at the PC end.**

The terminating impedance’s shown later in the wiring diagrams of Figure 4-1, Figure 4-2, Figure 4-4 & Figure 4-6 are automatically provided by the on board resistors and do not have to be added by the user.

**Fail Safe Open Circuit Detection.**

Open circuit is when there are no drivers on the circuit. This occurs by design in party line multi driver/receiver systems and

unintentionally when the twisted pair line is accidentally cut or disconnected or the transmitting device fails. In RS485 party line systems there are extended periods of time when none of the many possible talkers are gated onto the bus. This is known as the line idle state and occurs when all the driver outputs are in the high impedance state. The lines float, perhaps being pulled to the high or low state by noise or other voltages on the line.

Without fail safe open circuit detection false start bits are detected by the receivers, either corrupting good communications or causing noise to masquerade as good data.

The on board fail safe open circuit detection causes the receiver to go to a known, pre-determined state and prevents false start bits and bad data being detected during open circuits.

### **Fail Safe Short Circuit Protection.**

Short circuits are when the two lines of a twisted pair are connected together. This occurs due to either accidental damage to the cable or due to failure of one or more transmitter/receivers on the line. The short circuit condition is dangerous since damage to the receiver may occur and communication may be corrupted or prevented.

The on board fail safe short circuit detection prevents the line impedance from going to zero and thus protects the inputs of receivers and the outputs of drivers.

### **RS422 Operation.**

Generally, in RS422 systems all 8 signal lines from the 9 pin D connector participate in the data transfer sequence, thus 4 twisted pair cables are used. One twisted pair carries the TXD data outwards, one pair brings the RXD data inward, another pair carries the RTS handshake outwards and the fourth pair brings the CTS handshake inwards. There is no need to carry the ground from one device to another.

This RS422 arrangement allows data to be transmitted and received simultaneously since each signal has its own data cable pair. In addition, the receiver can set RTS true so telling the transmitter on its CTS input that the receiver is ready to accept data.

## PCMCIA 1 Port RS422/485

## Additional 422/485 Operation

In this way, no data will ever be transmitted when the receiver is unable to accept it, due to a full input buffer etc. And so no data will be lost.

### RS422 Serial Port Cables.

Use screened twisted pair Belden cable 9729 and 9829, L type 2493 and 2919 or IBM Part No 4716748 cable to make the RS422 connection. Unscreened Belden type 8795 may also be used in less noisy environments.

The on board resistor networks terminate the receiving end of the twisted pair cable in its characteristic impedance.

**Figure 4-1. Serial Port 1 To Other PC Cable.**

SERIAL PORT 1 Side  
9 Pin Female D Connector

Other PC SERIAL PORT Side.  
9 Pin Female D Connector

SCHEMATIC REPRESENTATION:

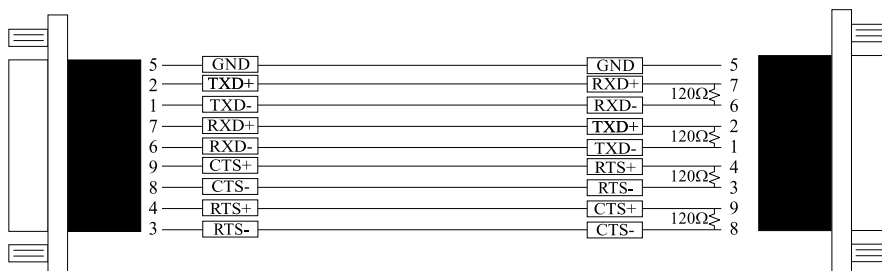

ACTUAL REPRESENTATION:

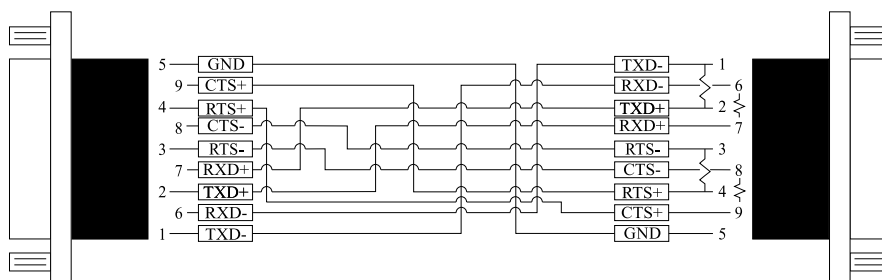

### Note:

Receiver ends terminated in characteristic impedance  
ONBOARD resistor networks.

USE BELDEN TYPE 9729 etc. see above.

RS485 Gating & Multiplex Jumpers as Factory Set.

**RS485 Operation.**

The RS485 standard is intended for up to 32 driver receiver pairs on the bus. The line drivers used in the Serial Solutions RS422/485 card are designed to work correctly in both RS422 and RS485 systems. The main difference therefore is in how the system is implemented. Though the card uses a 9 pin D connector, in general, not all the lines are used for RS485 systems. The RTS+/- and CTS+/- lines, though driven by the card, are usually not connected. In two wire, Half-Duplex configurations the TXD+ line is connected to the RXD+ whilst the TXD- line is connected to the RXD-, only one pair of twisted wire cable is used in RS485 Half Duplex communications.

The hardware handshaking performed by the CTS+/- and RTS+/- lines in RS422 systems are handled by a software protocol in RS485 systems. In situations where more than one device may transmit data on the shared data line, each cards RTS line is used as a gating signal to enable the TXD driver only when that card needs to transmit data, i.e. set TXD GATE or AUTO jumper. This mechanism prevents bus contention caused by multiple transmitters holding the line in opposing states. Revision 3 and higher versions of this card have a facility which automatically “gates” the RTS line, thus enabling the transmitter independently of any software. This “Auto gating” is described in more detail in the previous 485 half duplex section

The three wiring schemes given described below are: -

RS485 One Talker Many Listeners (HALF DUPLEX)

RS485 Many Talkers Many Listeners (HALF DUPLEX.)

RS485 Many Talkers Many Listeners (FULL DUPLEX.)

**RS485 Cable.**

For best noise immunity use twisted pair cables to make the RS485 connection. In Half Duplex wiring only 1 twisted cable pair is needed. Two twisted pair cables are needed for Full Duplex communications.

Use screened twisted pair Belden cable 9729 and 9829, UL type 2493 and 2919 or IBM Part No 4716748 cable to make the



RS485 connection. Terminate the twisted pair cable at either end in its characteristic impedance, which for the Belden 9729 cable is 120 Ohms. Unscreened Belden type 8795 may also be used in less noisy environments.

**RS485 One Talker - Many Listeners, Half Duplex.**

There are several schemes for connecting RS485 devices depending on the characteristics of the system. In many cases there will be only one device, which can transmit, data and all the others simply listen to it. This scheme is used for theatrical lighting intensity control in the DMX512 standard. This is shown in Figure 4-2, below. For the talker the RS485 TXD GATE jumper should remain in the factory set position, i.e. transmitter is always enabled. There is NO multiplexing of the TXD and RXD lines. Data is only flowing one way, from PC outwards, and is thus a Half-Duplex configuration, only one twisted pair cable is needed.

**Figure 4-2. RS485 1 Talker Many Listeners.**

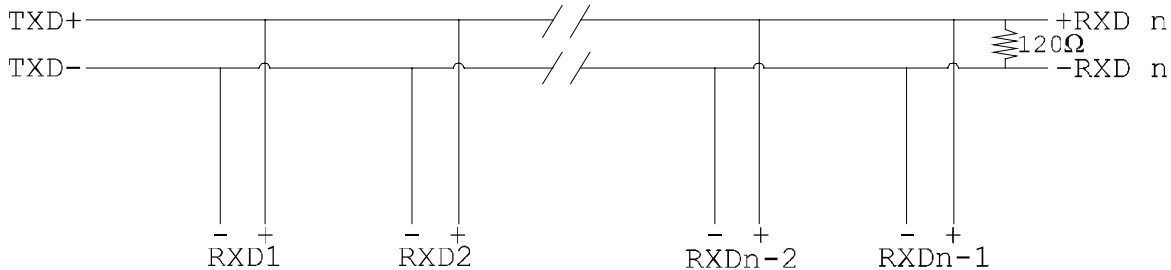

**Note:** The Receiver end of MAIN line terminated in characteristic impedance by ONBOARD resistor networks, stubs off the main not terminated.

In the above scheme, one RS485 device is talk only, it transmits data, but it does not receive any. The other RS485 devices are receive only, they do not transmit any data at all..

**Figure 4-3 Half Duplex Wiring**

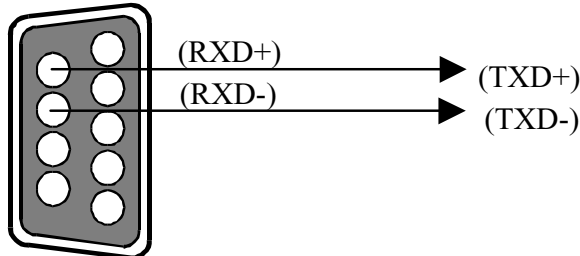

**RS485 Many Talkers- Many Listeners, Half Duplex.**

Another popular RS485 layout is for multiple talkers and multiple listeners. This is shown in Figure 4-4, below. This is also known as "party line" transmission. It is imperative to have some method of preventing two devices trying to drive the data lines at the same time. The normal method is to use the RTS line as a talk enable. The RTS line should go true immediately prior to the data transmission and go false immediately after the last byte in the stream is sent. See Figure 4-3 for jumper settings.

**Figure 4-4. RS485 Many Talkers & Listeners. Half Duplex**

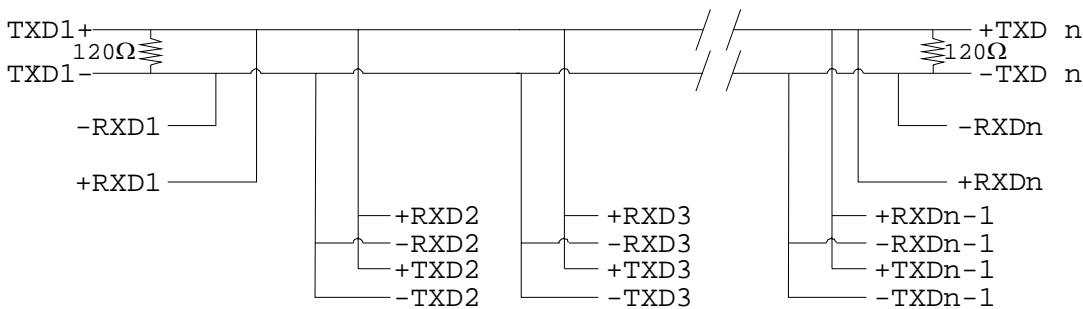

**Note:** BOTH ends of MAIN line terminated in characteristic impedance, stubs off main line not impedance, since both ends receive. The twisted pair ends are wired to both RXD+ & TXD+ and RXD- & TXD- at each RS485 device!

**RS485 Many Talkers- Many Listeners, Full Duplex.**

The RS485 many talkers, many listeners, Full Duplex system can be used when all the RS485 devices have separate Transmit and Receive channels. There is NO multiplexing of the TXD and RXD signals on the same device. This system is especially useful when there is no flow control available on the PC, usually due to the use of

a third party communications program that prevents the use of the RTS signal as a "transmit enable" control, via the TXD GATE jumper. It can be used in the following situations:-

- a) The PC is connected to only ONE RS485 device.
- b) The PC is communicating with several RS485 devices that are each able to recognize and respond to their own unique address.

The RS485 devices only drive their TXD lines when they are responding to requests from the PC to send data. In effect, the RS485 device's address and the command it receives is used to control access to the devices TXD channel.

This is a Full Duplex system. Two twisted pair cables are required. One twisted pair, is the PC's TXD channel, it carries the data sent from the PC's TXD outputs to the RXD inputs of each of the RS485 devices. The second twisted pair, is the Devices TXD channel, it carries the data sent from each of the devices' TXD outputs to the RXD inputs of the PC.

The advantages of this system are great, since no new communications, software is needed, and the PC can talk and listen at the same time. In effect, the handshaking is performed by the intelligence of the RS485 devices attached to the PC.

When wired as in Figure 4-6 below, the PC can transmit data at any time and all the RS485 devices #1 to #n simultaneously receives it.

Only one of the RS485 devices may talk, i.e. transmit data, at any one time. Each RS485 device recognizes commands and data addressed to it, it only talks when the PC commands it to do so. When the RS485 device receives the command to talk from the PC, it gates its TXD drivers on, sends the data down the device TXD channel, and disables its TXD drivers. The other RS485 devices remain in the receive only mode when they are not being addressed, they do not transmit any data at all.

**Figure 4-5. RS485 Full Duplex Wiring.**

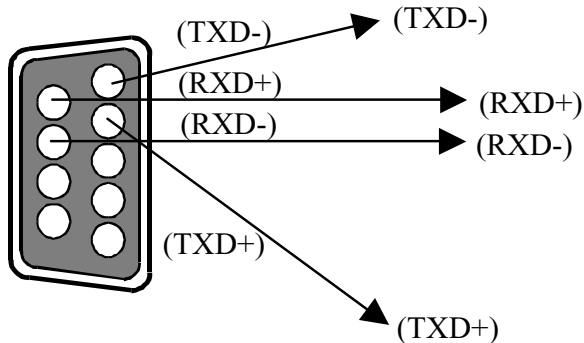

**Figure 4-6. RS485 Full Duplex.**

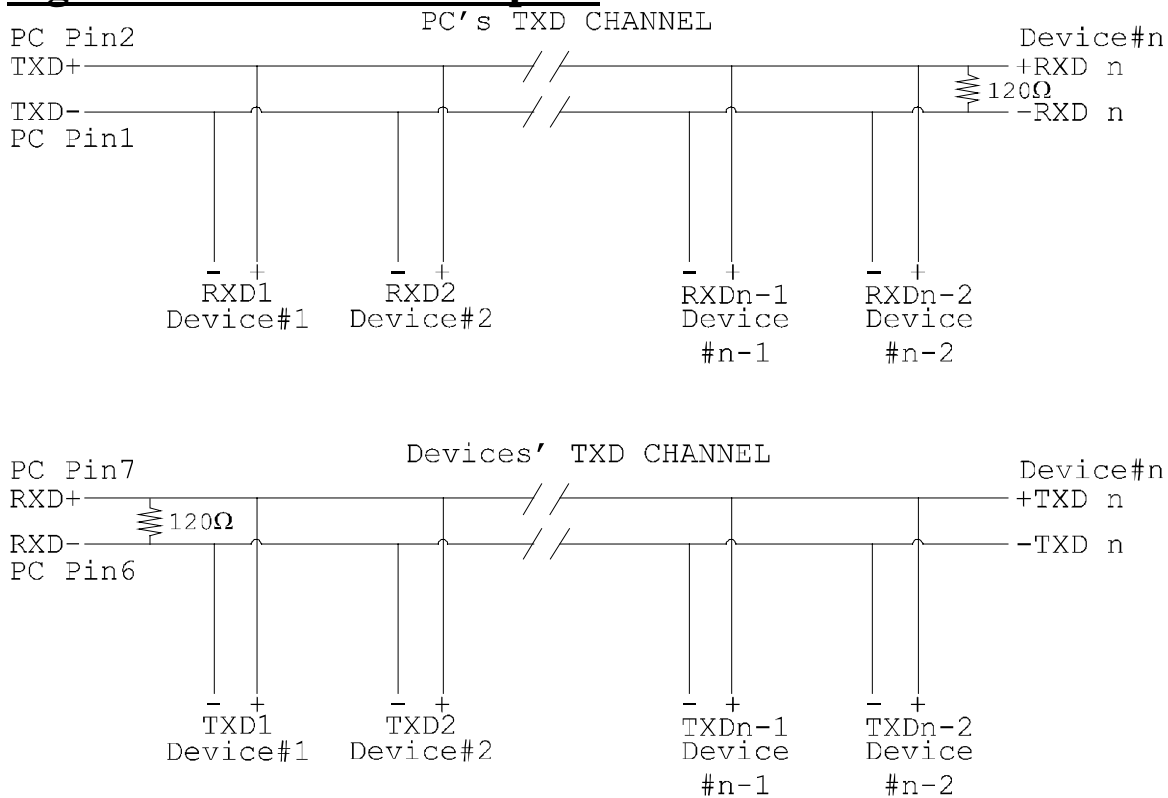

**Note:** The receiver end of MAIN line terminated in characteristic impedance, stubs off the main not terminated.

**Optional Grounding Arrangements.**

Proper operation of the cable circuit, according to TIA EIA: 485 A (1995) requires that the cable ground shield is not connected directly to the equipment ground shield. A current limiting resistor should be used in series with the shield to avoid possible large current flow due to differences in ground potential. Any one of the methods shown in Figure 4-7, below can do this.

**Figure 4-7 - Optional Grounding Arrangements For A PCI RS422/485 Card.**

**Configuration A)**

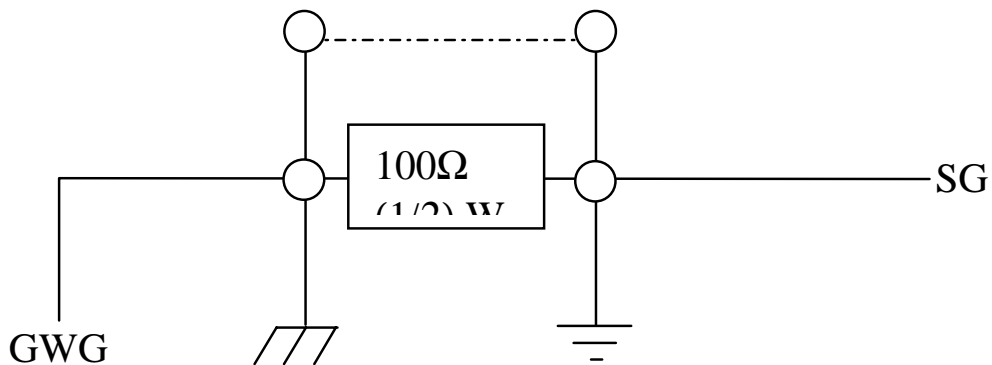

**Configuration B)**

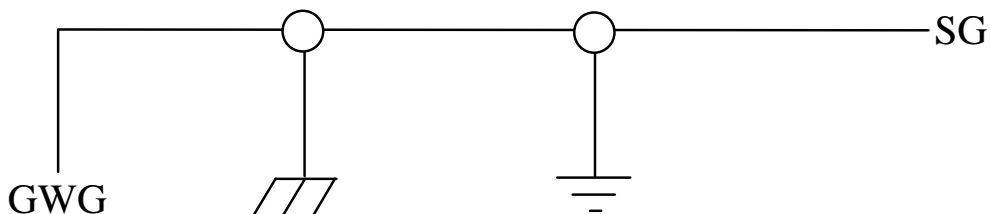

SG	=	Signal Ground Interchange circuit.
GWG	=	Green wire ground of power system.

**Configuration A)** The circuit common of the equipment is connected to protective ground, at one point only by a 100 Ω, ±20% resistor with a power dissipation rating of 1/2W. An additional provision may be made for the resistor to be bypassed with a strap to connect signal common and protective ground directly together when specific installation conditions necessitate.

**Configuration B)** The circuit common shall be connected directly to protective ground. The same configuration need not be used at both ends of an interconnection; however, care should be exercised to prevent establishment of ground loops carrying high currents. (Note: Under certain ground conditions in configuration A, above, high ground currents may cause the resistor to fail; therefore, a provision should be made for inspection and replacement of the resistor.)

**INDEX**

16450 / 16550 .....	5
asynchronous .....	5
baud / baud rate.....	5
Belden.....	38
bits .....	37
buffer .....	5, 38
buffered.....	5
cable.....	36, 37, 38, 39, 40
command .....	42
CTS.....	36, 37, 39
fail safe .....	37
FIFO.....	5
gating .....	39
handshake .....	37
impedance .....	36, 37, 38, 40, 41, 43
jumper.....	39, 40, 41, 42
last.....	41
mode .....	42
modem .....	5
open circuit .....	37
party line .....	36, 41
port / ports.....	5, 36
protocol.....	39
receive.....	40, 41, 42
resistor .....	35, 38, 40
RS232 .....	5, 7
RS422 / RS485 .....	35, 36, 37, 38, 39, 40, 41, 42, 43
RTS.....	35, 37, 39, 41, 42
RXD.....	36, 37, 39, 40, 41, 42
serial port .....	5, 36
short circuit .....	37
speed .....	5, 35
twisted pair.....	36, 37, 38, 39, 40, 41, 42
TXD.....	37, 39, 40, 41, 42
Windows .....	2