



Principales

Gamme de produits	Harmony XB5
Fonction produit	Tête
Destination du produit	Bouton-poussoir d'arrêt d'urgence
Nom abrégé de l'appareil	ZB5
Matériau de la collerette	Plastique
Diamètre de fixation	22 mm
Vente par quantité indivisible	1
Forme de la tête de l'unité de signalisation	Rond
Type d'unité de commande	Déclenchement et accrochage mécanique
Remise à zéro	Tourner pour déverrouiller
Profil de l'unité de commande	Rouge coup de poing Ø 30 mm non marqué

Complémentaires

Largeur hors tout CAO	30 mm
Hauteur hors tout CAO	30 mm
Profondeur hors tout CAO	57 mm
Poids	0.042 kg
Durée de vie mécanique	300000 cycle
Boite associée	XALD 1...5 trous XALK 1...5 trous
Electrical composition code	C11 pour <= 3 contacts using unique blocs en montage avant C15 pour 1 contacts using unique blocs en montage avant SF1 pour <= 3 contacts using unique blocs en montage avant SR1 pour <= 3 contacts using unique blocs en montage arrière C7 pour <= 4 contacts using unique blocs en montage avant C8 pour <= 4 contacts using simple et double blocs en montage avant C10 pour <= 4 contacts using simple et double blocs en montage avant

Environnement

traitement de protection	TH
température ambiante pour le stockage	-40...70 °C
température de fonctionnement	-40...70 °C
catégorie de surtension	Classe II conformément à IEC 60536
degré de protection IP	IP67 IP66 conformément à IEC 60529 IP69K IP69
tenue à l'environnement NEMA	NEMA 13 NEMA 4X
tenue au nettoyage haute pression	À 55 °C, distance: 0,1 m
Tenue aux chocs IK	IK03 conformément à IEC 50102
normes	EN/IEC 60204-1 EN/IEC 60947-1 EN/IEC 60947-5-1 EN/IEC 60947-5-4 EN/IEC 60947-5-5 EN/ISO 13850 IEC 60364-5-53 JIS C 4520 UL 508

certifications du produit	BV CSA DNV GL LROS (Lloyds register of shipping) RINA Listé UL
tenue aux vibrations	5 gn (f = 2...500 Hz) conformément à IEC 60068-2-6
tenue aux chocs mécaniques	30 gn (durée = 18 ms) pour accélération sur 1/2 sinusoïde conformément à IEC 60068-2-27 50 gn (durée = 11 ms) pour accélération sur 1/2 sinusoïde conformément à IEC 60068-2-27

Durabilité de l'offre

Statut environnemental	Produit Green Premium
RoHS (code date: AnnéeSemaine)	Conforme - depuis 0810 - Déclaration de conformité Schneider Electric
REACH	Référence ne contenant pas de SVHC au-delà du seuil
Profil environnemental du produit	Disponible
Instructions de fin de vie du produit	Pas d'opération de recyclage spécifiques

Contractual warranty

Période	18 mois
---------	---------

Dimensions

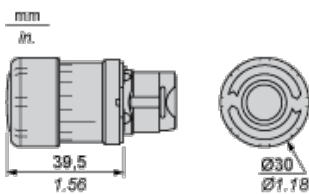

Panel Cut-out for Pushbuttons, Switches and Pilot Lights (Finished Holes, Ready for Installation)

Connection by Screw Clamp Terminals or Plug-in Connectors or on Printed Circuit Board

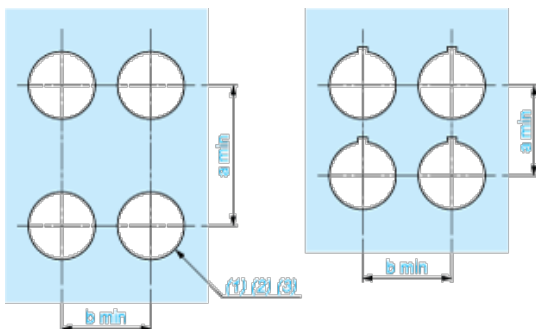

- (1) Diameter on finished panel or support
- (2) For selector switches and Emergency stop buttons, use of an anti-rotation plate type ZB5AZ902 is recommended.
- (3) $\varnothing 22.5$ mm recommended ($\varnothing 22.3_{0}^{+0.4}$) / $\varnothing 0.89$ in. recommended ($\varnothing 0.88$ in. $_{0}^{+0.016}$)

Connections	a in mm	a in in.	b in mm	b in in.
By screw clamp terminals or plug-in connector	40	1.57	30	1.18
By Faston connectors	45	1.77	32	1.26
On printed circuit board	30	1.18	30	1.18

Detail of Lug Recess

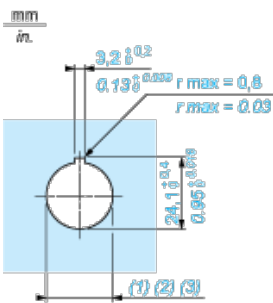

- (1) Diameter on finished panel or support
- (2) For selector switches and Emergency stop buttons, use of an anti-rotation plate type ZB5AZ902 is recommended.
- (3) $\varnothing 22.5$ mm recommended ($\varnothing 22.3 \text{ } ^{+0.4}$) / $\varnothing 0.89$ in. recommended ($\varnothing 0.88 \text{ in. } ^{+0.016}$)

Pushbuttons, Switches and Pilot Lights for Printed Circuit Board Connection

Panel Cut-outs (Viewed from Installer's Side)

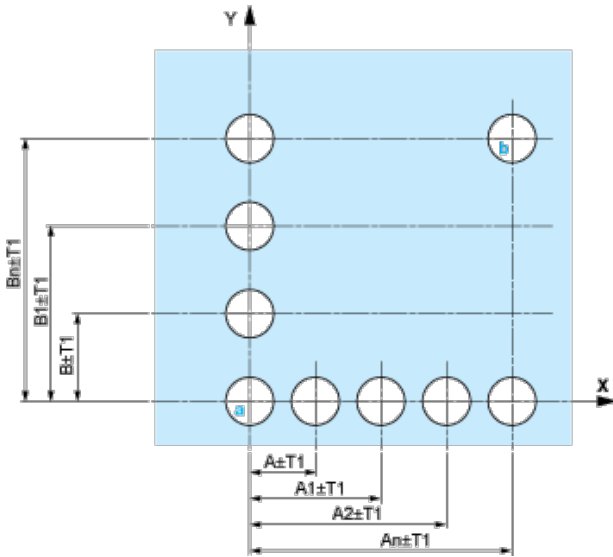

- A: 30 mm min. / 1.18 in. min.
 B: 40 mm min. / 1.57 in. min.

Printed Circuit Board Cut-outs (Viewed from Electrical Block Side)

Dimensions in mm

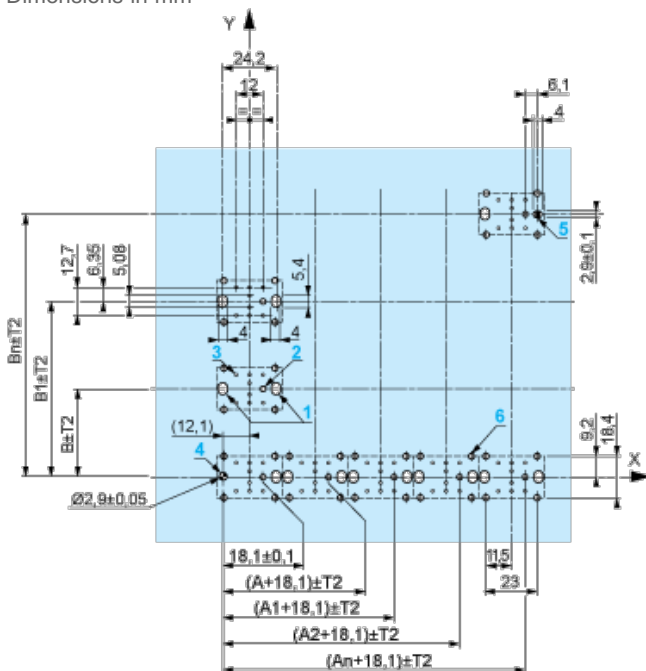

- A: 30 mm min.
 B: 40 mm min.

Dimensions in in.



A: 1.18 in. min.

B: 1.57 in. min.

General Tolerances of the Panel and Printed Circuit Board

The cumulative tolerance must not exceed 0.3 mm / 0.012 in.: $T1 + T2 = 0.3 \text{ mm max.}$

Installation Precautions

- | Minimum thickness of circuit board: 1.6 mm / 0.06 in.
- | Cut-out diameter: 22.4 mm \pm 0.1 / 0.88 in. \pm 0.004
- | Orientation of body/fixing collar ZB5AZ009: \pm 2°30' (excluding cut-outs marked **a** and **b**).
- | Tightening torque of screws ZBZ006: 0.6 N.m (5.3 lbf.in) max.
- | Allow for one ZB5AZ079 fixing collar/pillar and its fixing screws:
 - | every 90 mm / 3.54 in. horizontally (X), and 120 mm / 4.72 in. vertically (Y).
 - | with each selector switch head (ZB5AD•, ZB5AJ•, ZB5AG•).

The fixing centers marked **a** and **b** are diagonally opposed and must align with those marked **4** and **5**.



(1) Head ZB5AD•

(2) Panel

(2) Nut

(4) Printed circuit board

Mounting of Adapter (Socket) ZBZ01•

- | 1 2 elongated holes for ZBZ006 screw access
- | 2 1 hole \varnothing 2.4 mm \pm 0.05 / 0.09 in. \pm 0.002 for centring adapter ZBZ01•
- | 3 8 \times \varnothing 1.2 mm / 0.05 in. holes
- | 4 1 hole \varnothing 2.9 mm \pm 0.05 / 0.11 in. \pm 0.002, for aligning the printed circuit board (with cut-out marked **a**)

- | 5 1 elongated hole for aligning the printed circuit board (with cut-out marked **b**)
- | 6 4 holes \varnothing 2.4 mm / 0.09 in. for clipping in adapter ZBZ01•

Dimensions An + 18.1 relate to the \varnothing 2.4 mm \pm 0.05 / 0.09 in. \pm 0.002 holes for centring adapter ZBZ01•.

Electrical Composition Corresponding to Code C7



Electrical Compositions Corresponding to Code C8

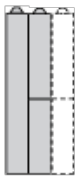

Electrical Compositions Corresponding to Code C10



Electrical Composition Corresponding to Codes C9, C11, SF1 and SR1

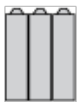

Electrical Composition Corresponding to Code C15

1 N/O



1 N/C



1 N/O + N/C or 1 N/O + N/O or 1 N/C + N/C

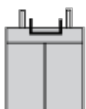

Legend

Single contact



Double contact



Light block



Possible location

