



CompactLogix™ Controllers

(Cat. No. 1769-L20, 1769-L30)

Inside...

For More Information	2
European Communities (EC) Directive Compliance	3
Hazardous Location Considerations	4
CompactLogix Controller Description	5
Install the Controller	5
Connect the Battery	6
Assemble the System	7
Mount the System	9
Grounding Considerations	12
Select the Controller's Operating Mode	12
RS-232 Connections to the Controller	13
Default Communication Configuration	14
Using the Channel 0 Default Communication Push Button	15
Troubleshoot the Controller Using the LEDs	16
Specifications	17
Dimensions	18
Battery Handling, Storing, and Transporting (Cat. No. 1747-BA)	19

For More Information

For	Refer to this Document	Pub. No.
A more detailed description of how to use your CompactLogix™ controllers.	CompactLogix™ System User Manual	1769-UM007C-EN-P
A programming guide for the Logix Instruction Set.	Logix5000™ Controllers Common Procedures Programming Manual	1756-PM001B-EN-P
A reference manual for the Logix Instruction Set.	Logix5000™ Controller General Instruction Set Reference Manual	1756-RM003D-EN-P
Information on installing and operating Compact I/O Power Supplies.	Compact™ 1769 Expansion I/O Power Supplies Installation Instructions	1769-IN028A-EN-P
Information on installing and operating Compact I/O.	Compact™ 1769 Expansion I/O Installation Instructions for your particular module	
More detailed information on installing and operating Compact I/O analog modules.	Compact™ 1769 I/O Analog Modules User Manual	1769-UM002A-EN-P
More detailed information on installing and operating the 1769 DeviceNet Adapter Module.	DeviceNet Adapter Module User Manual	1769-UM001A-US-P
Information on function block programming Logix5000 Controllers	Logix5000™ Controllers Process Control/Drives Instruction Set Reference Manual.	1756-RM006A-EN-P
More information on proper wiring and grounding techniques.	Industrial Automation Wiring and Grounding Guidelines	1770-4.1

If you would like a manual, you can:

- download a free electronic version from the internet:
www.theautomationbookstore.com
- purchase a printed manual by:
 - contacting your local distributor or Rockwell Automation representative
 - visiting **www.theautomationbookstore.com** and placing your order
 - calling **1.800.963.9548** (USA/Canada)
or **001.330.725.1574** (Outside USA/Canada)

TIP



Translated versions of the CompactLogix Controller Installation Instructions are available electronically. You can obtain a translated version of this publication at **www.theautomationbookstore.com**.

European Communities (EC) Directive Compliance

If this product has the CE mark it is approved for installation within the European Union and EEA regions. It has been designed and tested to meet the following directives.

EMC Directive

This product is tested to meet the Council Directive 89/336/EC Electromagnetic Compatibility (EMC) by applying the following standards, in whole or in part, documented in a technical construction file:

- EN 50081-2 EMC — Generic Emission Standard, Part 2 — Industrial Environment
- EN 50082-2 EMC — Generic Immunity Standard, Part 2 — Industrial Environment

This product is intended for use in an industrial environment.

Low Voltage Directive

This product is tested to meet Council Directive 73/23/EEC Low Voltage, by applying the safety requirements of EN 61131-2 Programmable Controllers, Part 2 - Equipment Requirements and Tests. For specific information required by EN 61131-2, see the appropriate sections in this publication, as well as the Allen-Bradley publication *Industrial Automation Wiring and Grounding Guidelines For Noise Immunity*, publication 1770-4.1. and the Automation Systems Catalog, B111.

This equipment is classified as open equipment and must be mounted in an enclosure during operation to provide safety protection.

Hazardous Location Considerations

This equipment is suitable for use in Class I, Division 2, Groups A, B, C, D or non-hazardous locations only. The following WARNING statement applies to use in hazardous locations.

WARNING



EXPLOSION HAZARD

- Substitution of components may impair suitability for Class I, Division 2.
 - Do not replace components or disconnect equipment unless power has been switched off or the area is known to be non-hazardous.
 - Do not connect or disconnect components unless power has been switched off or the area is known to be non-hazardous.
 - This product must be installed in an enclosure. All cables connected to the product must remain in the enclosure or be protected by conduit or other means.
 - All wiring must comply with N.E.C. article 501-4(b).
-

Environnements dangereux

Cet équipement est conçu pour être utilisé dans des environnements de Classe 1, Division 2, Groupes A, B, C, D ou non dangereux. La mise en garde suivante s'applique à une utilisation dans des environnements dangereux.

AVERTISSEMENT



DANGER D'EXPLOSION

- La substitution de composants peut rendre cet équipement impropre à une utilisation en environnement de Classe 1, Division 2.
 - Ne pas remplacer de composants ou déconnecter l'équipement sans s'être assuré que l'alimentation est coupée et que l'environnement est classé non dangereux.
 - Ne pas connecter ou déconnecter des composants sans s'être assuré que l'alimentation est coupée ou que l'environnement est classé non dangereux.
 - Ce produit doit être installé dans une armoire.
-

CompactLogix Controller Description

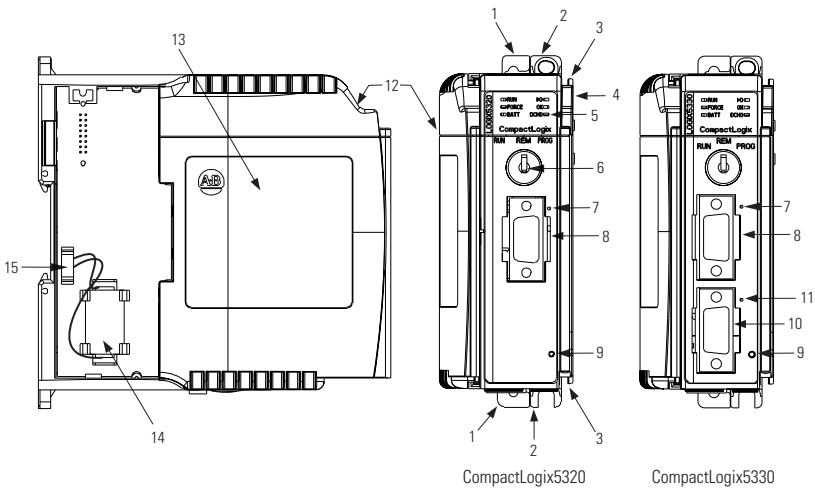

1	DIN rail latch	8	Channel 0 RS-232 Port
2	panel mounting tab	9	Channel 0 default communication push button
3	tongue and groove slots	10	Channel 1 RS-232 Port
4	stationary bus connector	11	Channel 1 RS-232 Port Status LED
5	status LEDs	12	battery door
6	key switch	13	battery door label
7	Channel 0 RS-232 Port Status LED	14	battery ⁽¹⁾
		15	battery connector

(1) See Connect the Battery on page 6 for the actual position of the battery.

Install the Controller

The CompactLogix5320 and 5330 controllers are suitable for use in an industrial environment when installed in accordance with these instructions. Specifically, this equipment is intended for use in clean, dry environments (Pollution Degree 2⁽¹⁾) and with circuits not exceeding Over Voltage Category II⁽²⁾ (IEC 60664-1).⁽³⁾

- (1) Pollution Degree 2 is an environment where, normally, only non-conductive pollution occurs except that occasionally a temporary conductivity caused by condensation shall be expected.
- (2) Over Voltage Category II is the load level section of the electrical distribution system. At this level transient voltages are controlled and do not exceed the impulse voltage capability of the product's insulation.
- (3) Pollution Degree 2 and Over Voltage Category II are International Electrotechnical Commission (IEC) designations.

Prevent Electrostatic Discharge

ATTENTION



Electrostatic discharge can damage integrated circuits or semiconductors if you touch bus connector pins. Follow these guidelines when you handle the module:

- Touch a grounded object to discharge static potential.
 - Wear an approved wrist-strap grounding device.
 - Do not touch the bus connector or connector pins.
 - Do not touch circuit components inside the module.
 - If available, use a static-safe work station.
 - When not in use, keep the module in its static-shield bag.
-

Remove Power

ATTENTION



Remove power before removing or inserting this module. When you remove or insert a module with power applied, an electrical arc may occur. An electrical arc can cause personal injury or property damage by:

- sending an erroneous signal to your system's field devices, causing unintended machine motion
- causing an explosion in a hazardous environment

Electrical arcing causes excessive wear to contacts on both the module and its mating connector. Worn contacts may create electrical resistance.

Connect the Battery

The controller is shipped with the battery packed separately. To connect the battery, follow the procedure shown below.

1. Slide the battery door (a) forward.
2. Insert the battery (b) into the battery port. Insert the battery connector into the connector port (c). The connector is keyed to engage only in the correct polarity.
3. Slide the battery door (a) back until it clicks into position.

For information on battery handling, see page 19.

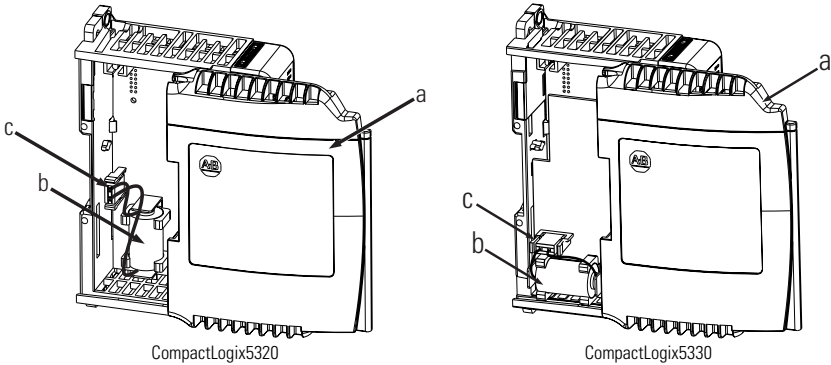

System Planning

Consider the following when planning your CompactLogix system:

- The CompactLogix controller is always the left-most module in the system.
- The controller must be located within four modules of the system power supply. Some I/O module's may be located up to 8 modules away from the power supply. See the documentation for your 1769 I/O modules for details.
- The CompactLogix5320 controller supports up to 8 I/O modules in a maximum of 2 I/O banks (1 expansion cable allowed).
- The CompactLogix5330 controller supports up to 16 I/O modules in a maximum of 3 I/O banks (2 expansion cables allowed).
- Each I/O bank requires its own power supply.
- Only one controller can be used in a CompactLogix system.
- A 1769-ECR (right end cap) or 1769-ECL (left end cap) is required to terminate the end of the communication bus.

Assemble the System

The controller can be attached to an adjacent I/O module or power supply *before* or *after* mounting. For mounting instructions, see “Panel Mounting” on page 9, or “DIN Rail Mounting” on page 11.

The following procedure shows you how to install the controller in a CompactLogix system.

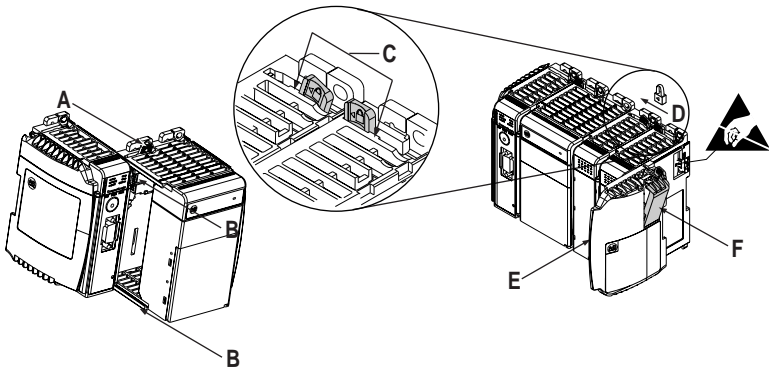

1. Disconnect line power.
2. Check that the lever of the adjacent module (A) is in the unlocked (fully right) position.
3. Use the upper and lower tongue-and-groove slots (B) to secure the modules together.
4. Move the module back along the tongue-and-groove slots until the bus connectors line up with each other.
5. Use your fingers or a small screwdriver to push the module's bus lever back slightly to clear the positioning tab (C).
6. Move the module's bus lever fully to the left (D) until it clicks. Ensure it is locked firmly in place.

ATTENTION



When attaching the controller, power supply, and I/O modules, it is very important that the bus connectors are securely locked together to ensure proper electrical connection.

7. Attach an end cap terminator (E) to the last module in the system by using the tongue-and-groove slots as before.
8. Lock the end cap bus terminator (F).

Mount the System

ATTENTION



During panel or DIN rail mounting of all devices, be sure that all debris (metal chips, wire strands, etc.) is kept from falling into the controller. Debris that falls into the controller could cause damage while the controller is energized.

Minimum Spacing

Maintain spacing from enclosure walls, wireways, adjacent equipment, etc. Allow 50 mm (2 in.) of space on all sides, as shown. This provides ventilation and electrical isolation.

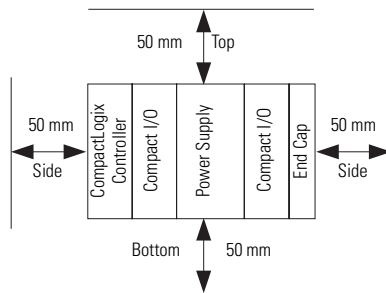

Panel Mounting

Mount the controller to a panel using two screws per module. Use M4 or #8 panhead screws. Mounting screws are required on every module.

Panel Mounting Using the Dimensional Template

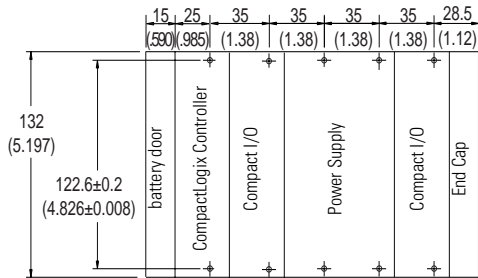

NOTE: All dimensions are in mm (in.).
 Hole spacing tolerance: ±0.4 mm (0.016 in.)

Panel Mounting Procedure Using Modules as a Template

The following procedure allows you to use the assembled modules as a template for drilling holes in the panel. If you have sophisticated panel mounting equipment, you can use the dimensional template provided on page 10. Due to module mounting hole tolerance, it is important to follow these procedures:

1. On a clean work surface, assemble no more than three modules.
2. Using the assembled modules as a template, carefully mark the center of all module-mounting holes on the panel.
3. Return the assembled modules to the clean work surface, including any previously mounted modules.
4. Drill and tap the mounting holes for the recommended M4 or #8 screw.
5. Place the modules back on the panel and check for proper hole alignment.
6. Attach the modules to the panel using the mounting screws.

TIP

If mounting more modules, mount only the last one of this group and put the others aside. This reduces remounting time during drilling and tapping of the next group.

7. Repeat steps 1 to 6 for any remaining modules.

DIN Rail Mounting

The controller can be mounted using the following DIN rails:

- 35 x 7.5 mm (EN 50 022 - 35 x 7.5)
- 35 x 15 mm (EN 50 022 - 35 x 15)

Before mounting the controller on a DIN rail, close the DIN rail latches. Press the DIN rail mounting area of the controller against the DIN rail. The latches will momentarily open and lock into place.

Grounding Considerations

This product is intended to be mounted to a well-grounded mounting surface such as a metal panel. Additional grounding connections from the controller's mounting tabs or DIN rail (if used), are not required unless the mounting surface cannot be grounded. Refer to *Industrial Automation Wiring and Grounding Guidelines*, Allen-Bradley publication 1770-4.1, for additional information.

Select the Controller's Operating Mode

Use the keyswitch on the front panel of the controller to determine the controller's operating mode.

Keyswitch Position	Description	
RUN	<ul style="list-style-type: none"> Run the program and enable outputs. You cannot create or delete tasks, programs, or routines. You cannot create or delete tags or edit online while the keyswitch is in the RUN position. You cannot change the mode using the programming software while the keyswitch is in the RUN position. 	
PROG	<ul style="list-style-type: none"> Disable outputs. Upload projects. Create, modify, and delete tasks, programs, or routines. The controller does not execute (scan) tasks while the keyswitch is in the PROG position. You cannot change the mode through the programming software while the keyswitch is in the PROG position. 	
REM	Change between Remote Program, Remote Test, and Remote Run modes through the programming software.	
	Remote Run	<ul style="list-style-type: none"> The controller executes (scans) tasks. Enable outputs. Edit online.
	Remote Program	<ul style="list-style-type: none"> Disable outputs. Create, modify, and delete tasks, programs or routines. Download projects. Edit online. The controller does not execute (scan) tasks.
	Remote Test	<ul style="list-style-type: none"> Execute tasks with outputs disabled. Edit online.

RS-232 Connections to the Controller

The following illustrations show which cables can be used to connect to the controller. To connect two cables to the CompactLogix5330, you must connect the straight cable end to Channel 0.

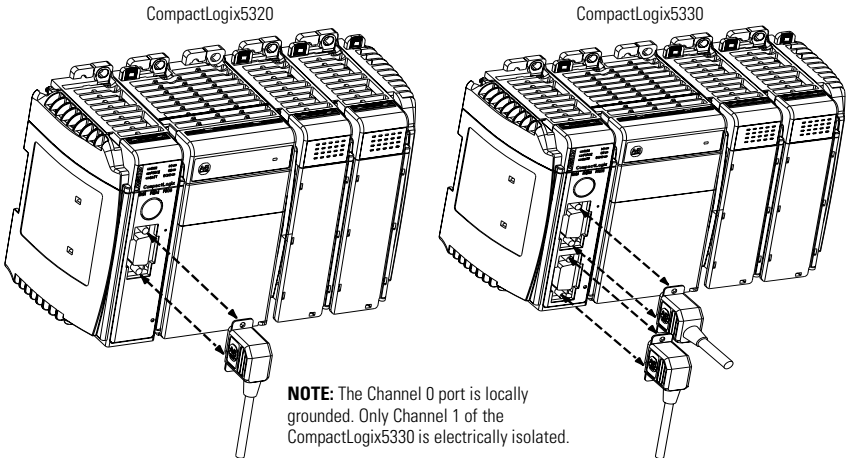

ATTENTION



When you connect or disconnect the serial cable while backplane power is on, an electrical arc can occur. In hazardous locations, this could cause an explosion.

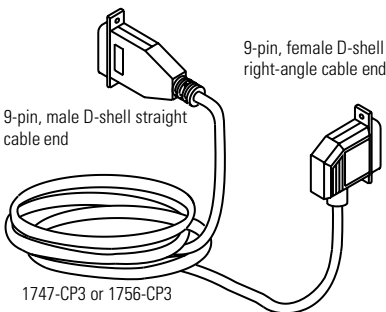

This cable must be shielded and tied to the connector housing.

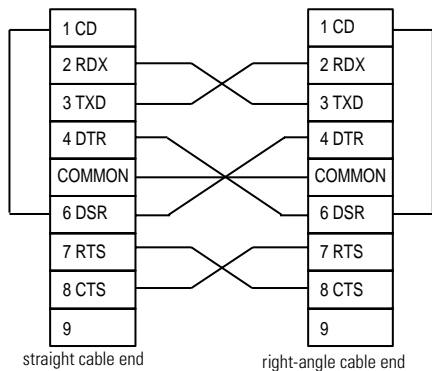

Default Communication Configuration

Channel 0 and Channel 1 (CompactLogix5330 only) have the following default communication configuration.

Parameter	Default
Protocol	DF1 full-duplex
Baud Rate	19.2K
Parity	none
Station Address	0
Control Lines	no handshaking
Error Detection	BCC
Embedded Responses	auto detect
Duplicate Packet (Message) Detect	enabled
ACK Timeout	50 (x 20 ms)
NAK Receive Limit	3 retries
ENQ Transmit Limit	3 retries
Data Bits	8
Stop Bits	1

Using the Channel 0 Default Communication Push Button

The Channel 0 Default Communication Push Button is located on the front of the controller in the lower right corner as shown in the illustration below.

Use the Channel 0 Default Communication Push Button to change from the user-defined communication configuration to the default communications mode. The Channel 0 Default Communications (DCH0) LED turns on (green, steady) to show when the default communication configuration is active.

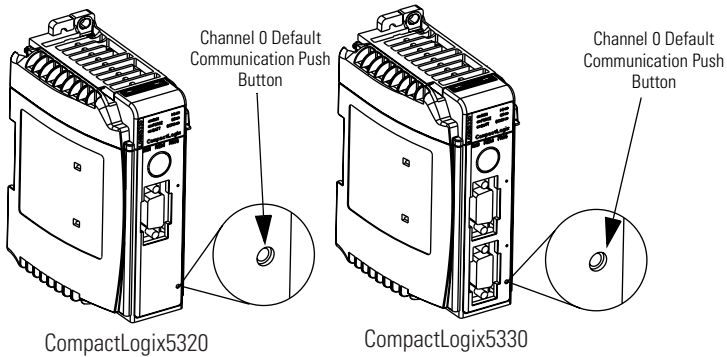

TIP



- The Default Communication Push Button is recessed.
- Before pressing the Default Communication Push Button, be sure to note the present communication configuration for Channel 0. Pushing the Default Communication Push Button resets all configured parameters back to their default settings. To return the channel to its user-configured parameters, you must enter them manually while online with the controller or download them as part of an RSLogix 5000 Project file. To accomplish this online using RSLogix 5000, enter the Controller Properties screen and use the Serial Port, System Protocol and User Protocol tabs.

Troubleshoot the Controller Using the LEDs

Indicator	Color/Status	Description
RUN	Off	No task(s) running Controller in Program mode
	Green	One or more tasks are running Controller is in the Run mode
FORCE	Off	No forces enabled
	Amber	Forces enabled
	Amber Flashing	One or more input or output addresses have been forced to an On or Off state, but the forces have not been enabled
BAT	Off	Battery supports memory
	Red	Battery may not support memory, replace battery
OK	Off	No power applied
	Green	Controller OK
	Red flashing	Recoverable controller fault
	Red	Non-recoverable controller fault: Cycle power. The OK LED should change to flashing red. If LED remains solid red, replace the controller.
I/O	Off ⁽¹⁾	No activity No I/O or communications configured
	Green	Communicating to all modules
	Green flashing	One or more modules not responding
	Red flashing	Not communicating to any modules
DCHO	Off	User-configured communications active
	Green	Default communication configuration active
Channel 0	Off	No activity
	Green	Network activity (DH485)
	Green flickering	Data is being received or transmitted (DF1)
Channel 1	Off	No activity
	Green	Network activity (DH485)
	Green flickering	Data is being received or transmitted (DF1)

(1) If the controller does not contain an application (controller memory is empty), the I/O indicator will be off.

Specifications

Description	CompactLogix5320	CompactLogix5330
Communication Ports	(1) RS-232	(2) RS-232
User Memory	64K bytes	256K bytes
Maximum number of I/O modules supported	8 I/O modules	16 I/O modules
Maximum number of I/O banks supported	2 banks	3 banks
Backplane Current	600 mA at +5V dc 0 mA at +24V dc	800 mA at +5V dc 0 mA at +24V dc
Operating Temperature	0° to +60°C (+32° to +140°F)	
Storage Temperature	-40° to +85°C (-40° to +185°F)	
Relative Humidity	5% to 95% non-condensing	
Power Supply Distance Rating	4 (The controller must be within four slot positions of the power supply.)	
Vibration	Operating: 10 to 500 Hz, 5G, 0.030 in. peak-to-peak	
Shock	Operating: 30G, 11 ms, panel mounted (20G, 11 ms, DIN rail mounted) Non-operating: 40G, panel mounted (30G, DIN rail mounted)	
Shipping Weight	325g (0.715 lbs)	360g (0.792 lbs)
Battery	1747-BA	
Programming Cable	1747-CP3 or 1756-CP3	
Agency Certification	<ul style="list-style-type: none"> • C-UL certified (under CSA C22.2 No.142) • UL 508 listed • CE compliant for all applicable directives 	
Hazardous Environment Class	Class I, Division 2, Hazardous Location, Groups A, B, C, D (UL 1604, C-UL under CSA C22.2 No. 213)	
Radiated and Conducted Emissions	EN50081-2 Class A	
<i>Electrical /EMC:</i>	<i>The unit has passed testing at the following levels:</i>	
ESD Immunity (IEC61000-4-2)	4 kV contact, 8 kV air, 4 kV indirect	
Radiated Immunity (IEC61000-4-3)	10 V/m, 80 to 1000 MHz, 80% amplitude modulation, +900 MHz keyed carrier	
Fast Transient Burst (IEC61000-4-4)	2 kV, 5 kHz	
Surge Immunity (IEC61000-4-5)	1 kV galvanic gun	
Conducted Immunity (IEC61000-4-6)	10V, 0.15 to 80 MHz ⁽¹⁾	

(1) Conducted Immunity frequency range may be 150 kHz to 30 MHz if the Radiated Immunity frequency range is 30 MHz to 1000 MHz.

Dimensions

CompactLogix Controller

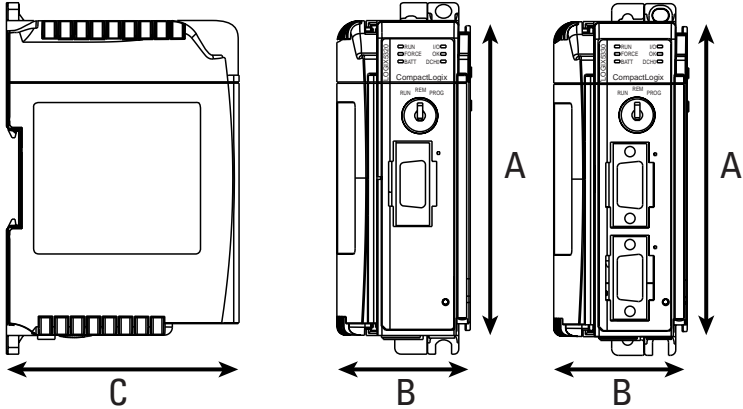

NOTE: All dimensions are in mm (in.).
Hole spacing tolerance: ± 0.4 mm (0.016 in.)

CompactLogix5320

CompactLogix5330

Height (A)	118 mm (4.649 in.)
Width (B)	50 mm (1.97 in.)
Depth (C)	87 mm (3.43 in.)

See page 10 for CompactLogix System dimensions.

Compact I/O Expansion Cable, I/O, Power Supply and End Cap

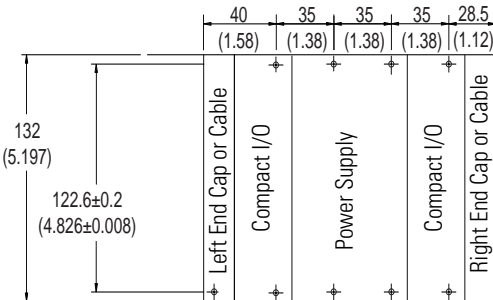

NOTE: All dimensions are in mm (in.).
Hole spacing tolerance: ± 0.4 mm (0.016 in.)

TIP



Compact I/O expansion cables have the same dimensions as the end caps. Expansion cables can be used on either the right or left end. A 1769-ECR (right end cap) or 1769-ECL (left end cap) is required to terminate the end of the communication bus.

Battery Handling, Storing, and Transporting (Cat. No. 1747-BA)

Handling

ATTENTION

Do not charge the batteries. An explosion could result or the cells could overheat causing burns. Do not open, puncture, crush, or otherwise mutilate the batteries. An explosion may result and/or toxic, corrosive, and flammable liquids would be exposed.

Storing

Store the lithium batteries in a cool, dry environment, typically +20°C to +25°C (+68°F to +77°F) and 40% to 60% relative humidity.

Transporting

One or Two Batteries - Up to two batteries can be shipped together within the United States without restriction. Regulations governing shipment to or within other countries may differ.

Three or More Batteries - Procedures for the transportation of three or more batteries shipped together within the United States are specified by the Department of Transportation (DOT) in the Code of Federal Regulations, CFR49, "Transportation". An exemption to these regulations, DOT - E7052, covers the transport of certain hazardous materials classified as flammable solids. This exemption authorizes transport of lithium batteries by motor vehicle, rail freight, cargo vessel, and cargo-only aircraft, providing certain conditions are met. Transport by passenger aircraft is not permitted.

Shipment of depleted batteries for disposal may be subject to specific regulation of the countries involved or to regulations endorsed by those countries, such as the IATA Restricted Articles Regulations of the International Air Transport Association, Geneva, Switzerland.

IMPORTANT

Regulations for transportation of lithium batteries are periodically revised.

ATTENTION

Do not incinerate or dispose of lithium batteries in general trash collection. Explosion or violent rupture is possible. Batteries should be collected for disposal in a manner to prevent against short circuiting, compacting, or destruction of case integrity and hermetic seal.

For disposal, batteries must be packaged and shipped in accordance with transportation regulations, to a proper disposal site. The U.S. Department of Transportation authorizes shipment of "Lithium batteries for disposal" by motor vehicle only in regulation 173.1015 of CFR 49 (effective January 5, 1983). For additional information contact:

U.S. Department of Transportation
Research and Special Programs Administration
400 Seventh Street, S.W.
Washington, D.C. 20590

Although the Environmental Protection Agency at this time has no regulations specific to lithium batteries, the material contained may be considered toxic, reactive, or corrosive. The person disposing of the material is responsible for any hazard created in doing so. State and local regulations may exist regarding the disposal of these materials.

For a lithium battery material safety data sheet, contact the manufacturer:

Sanyo Energy Corporation
600 Supreme Drive
Bensenville, IL 60106

CompactLogix and RSLogix 5000 are trademarks of Rockwell Automation.

Reach us now at www.rockwellautomation.com

Wherever you need us, Rockwell Automation brings together leading brands in industrial automation including Allen-Bradley controls, Reliance Electric power transmission products, Dodge mechanical power transmission components, and Rockwell Software. Rockwell Automation's unique, flexible approach to helping customers achieve a competitive advantage is supported by thousands of authorized partners, distributors and system integrators around the world.

Americas Headquarters, 1201 South Second Street, Milwaukee, WI 53204, USA, Tel: (1) 414 382-2000, Fax: (1) 414 382-4444
European Headquarters SA/NV, avenue Herrmann Diebroux, 46, 1160 Brussels, Belgium, Tel: (32) 2 663 06 00, Fax: (32) 2 663 06 40
Asia Pacific Headquarters, 27/F Citicorp Centre, 18 Whitfield Road, Causeway Bay, Hong Kong, Tel: (852) 2887 4788, Fax: (852) 2508 1846



Publication 1769-IN047B-EN-P - June 2001

Supersedes Publication 1769-IN047A-EN-P - October 2000

PN 40072-100-01(B)

© 2001 Rockwell International Corporation. Printed in the U.S.A.