

Portalampade e portastarter per lampade fluorescenti - Ambiente asciutto

26.514.5011

Portastarter

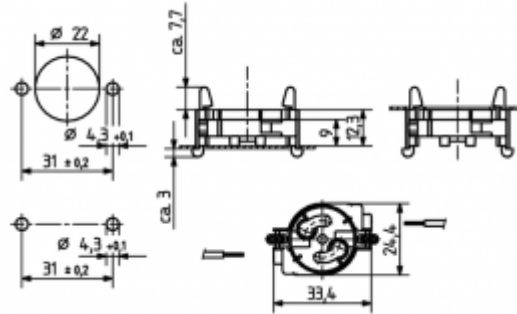

Colore Imb. Peso Codice
bianco 500 3 g 26.514.5011.50

Approvazione: in aggiunta cULus (660W / 250V)

Perni ad innesto superiori e inferiori

Corpo: PC

T 100			
		18 AWG 0,5 - 1,0 mm ²	0,5 - 1,1