

THIS DRAWING IS UNPUBLISHED. RELEASED FOR PUBLICATION
 © COPYRIGHT - By - ALL RIGHTS RESERVED.

LOC	DIST	REVISIONS					
G	14	P	LTR	DESCRIPTION	DATE	DWN	APVD
			K2	REVISED PER ECO-11-004917	11MAR11	RK	HMR

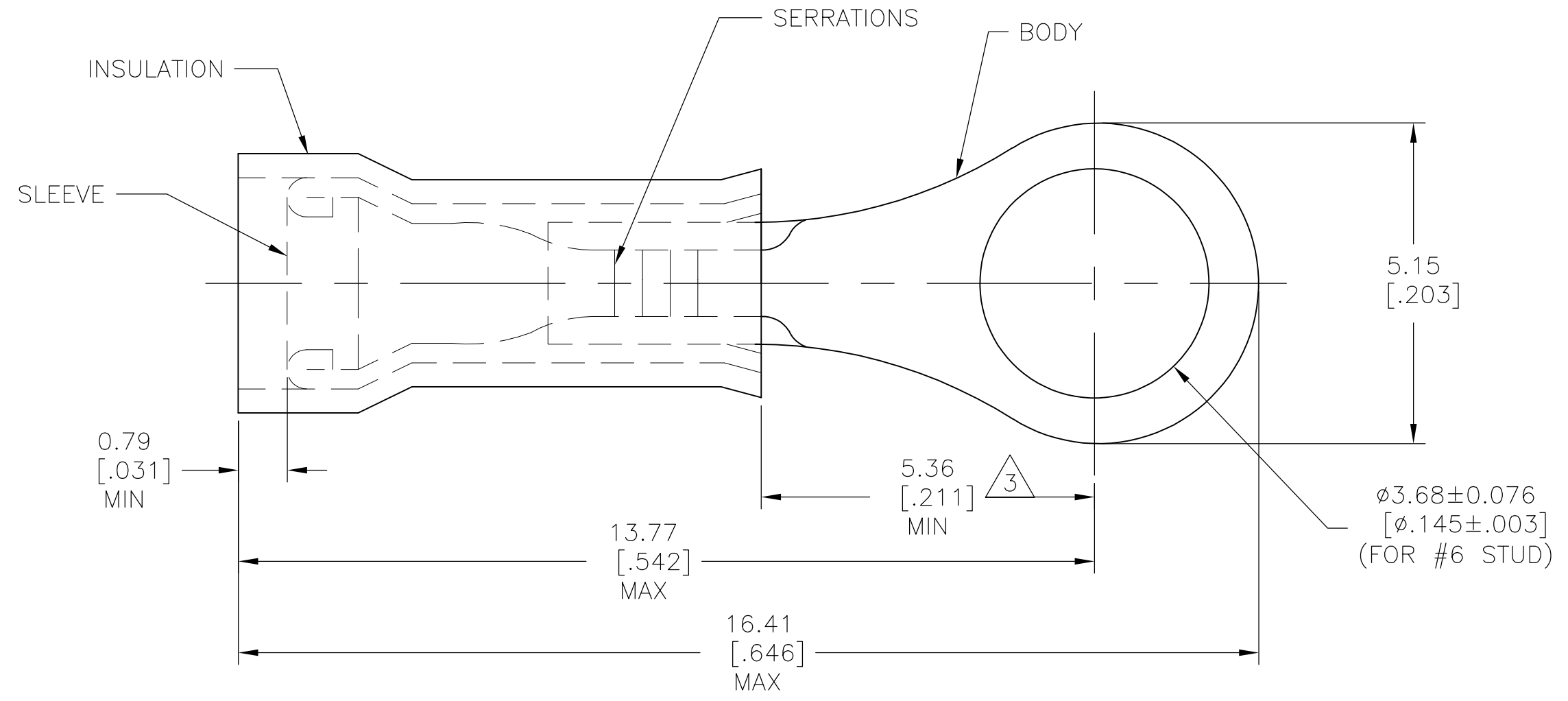

- 1 FOR 1.27[.050] TO 2.08[.082] WIRE INSULATION DIA
- 2 TONGUE MATERIAL THK 0.46±0.05[.018±.002]
- 3 APPLIES FROM EDGE OF METAL BARREL TO CENTERLINE OF STUD HOLE.

-	100	LOOSE PC, BOX	BODY: COPPER ASTM-B152 TIN PL ASTM-B545	8-323915-1
-	4000	ON TAPE, REEL	SLEEVE: COPPER ASTM-B152 TIN PL ASTM-B545	2-323915-2
2-323915-2	1	WIRE TERMINAL	INSULATION: NYLON ASTM-D4066 COLOR: YELLOW, TYPE I	323915
PART NO ON TAPE	QTY	DESCRIPTION	MATERIAL & FINISH	PART NO

THIS DRAWING IS A CONTROLLED DOCUMENT.		DWN RAGHAVENDRA 18MAR10	STE TE Connectivity	
DIMENSIONS: mm [INCHES]		CHK JEFF RUTH 18MAR10		
TOLERANCES UNLESS OTHERWISE SPECIFIED:		APVD TOM MICHIELUTTI 18MAR10	NAME	
0 PLC ± -		PRODUCT SPEC	WIRE TERMINAL	
1 PLC ± -		APPLICATION SPEC	PIDG - RING TONGUE	
2 PLC ± -		WEIGHT -	WIRE SIZE: 26-22	
3 PLC ± 0.20[.008]		SIZE	CAGE CODE	DRAWING NO
4 PLC ± -		A3	00779	C-323915
ANGLES ± 0° 30'		RESTRICTED TO		
MATERIAL SEE TABLE	FINISH SEE TABLE	CUSTOMER DRAWING		SCALE 12:1
			SHEET 1 OF 1	REV K2