

# EFR32FG1 Flex Gecko Proprietary Protocol SoC Family Data Sheet



The Flex Gecko proprietary protocol family of SoCs is part of the Wireless Gecko portfolio. Flex Gecko SoCs are ideal for enabling energy-friendly proprietary protocol networking for IoT devices.

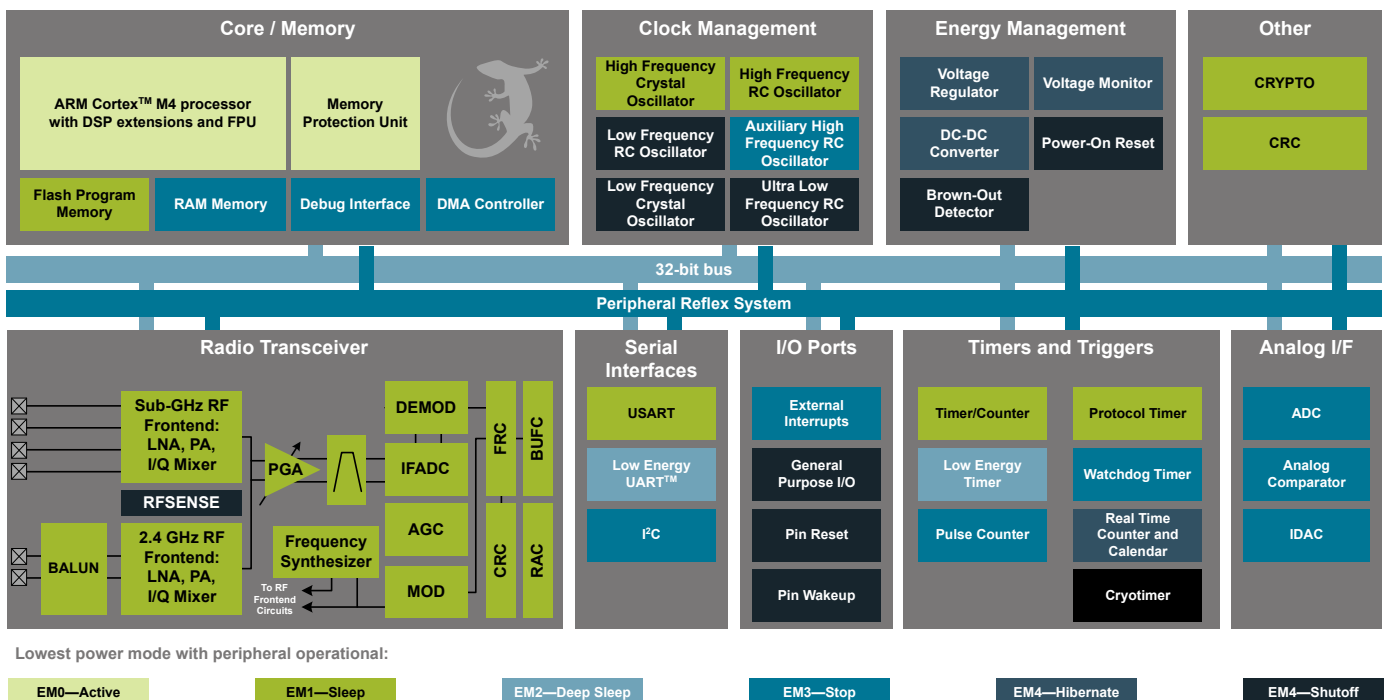
The single-die solution provides industry-leading energy efficiency, ultra-fast wakeup times, a scalable power amplifier, an integrated balun and no-compromise MCU features.

Flex Gecko applications include:

- Home and Building Automation and Security
- Metering
- Electronic Shelf Labels
- Industrial Automation
- Commercial and Retail Lighting and Sensing

## KEY FEATURES

- 32-bit ARM® Cortex®-M4 core with 40 MHz maximum operating frequency
- Scalable Memory and Radio configuration options available in several footprint compatible QFN packages
- 12-channel Peripheral Reflex System enabling autonomous interaction of MCU peripherals
- Autonomous Hardware Crypto Accelerator and Random Number Generator
- Integrated balun for 2.4 GHz and integrated PA with up to 19.5 dBm transmit power for 2.4 GHz and 20 dBm transmit power for Sub-GHz radios
- Integrated DC-DC with RF noise mitigation



## 1. Feature List

The EFR32FG1 highlighted features are listed below.

- **Low Power Wireless System-on-Chip.**
  - High Performance 32-bit 40 MHz ARM Cortex<sup>®</sup>-M4 with DSP instruction and floating-point unit for efficient signal processing
  - Up to 256 kB flash program memory
  - Up to 32 kB RAM data memory
  - 2.4 GHz and Sub-GHz radio operation
  - Transmit power:
    - 2.4 GHz radio: Up to 19.5 dBm
    - Sub-GHz radio: Up to 20 dBm
- **Low Energy Consumption**
  - 8.7 mA RX current at 2.4 GHz
  - 8.2 mA TX current @ 0 dBm output power at 2.4 GHz
  - 8.1 mA RX current at 868 MHz
  - 34.5 mA TX current @ 14 dBm output power at 868 MHz
  - 63  $\mu$ A/MHz in Active Mode (EM0)
  - 1.4  $\mu$ A EM2 DeepSleep current (full RAM retention and RTCC running from LFXO)
  - 0.58  $\mu$ A EM4H Hibernate Mode (128 byte RAM retention)
  - Wake on Radio with signal strength detection, preamble pattern detection, frame detection and timeout
- **High Receiver Performance**
  - -94 dBm sensitivity @ 1 Mbit/s GFSK (2.4GHz)
  - -121.4 dBm sensitivity at 2.4 kbps GFSK (868 MHz)
- **Supported Modulation Formats**
  - 2-FSK / 4-FSK with fully configurable shaping
  - Shaped OQPSK / (G)MSK
  - Configurable DSSS and FEC
  - BPSK / DBPSK TX
  - OOK / ASK
- **Supported Protocols:**
  - Proprietary Protocols
  - Wireless M-Bus
  - Low Power Wide Area Networks
- **Support for Internet Security**
  - General Purpose CRC
  - Random Number Generation
  - Hardware Cryptographic Acceleration for AES 128/256, SHA-1, SHA-2 (SHA-224 and SHA-256) and ECC
- **Wide selection of MCU peripherals**
  - 12-bit 1 Msps SAR Analog to Digital Converter (ADC)
  - 2 $\times$  Analog Comparator (ACMP)
  - Digital to Analog Current Converter (IDAC)
  - Up to 32 pins connected to analog channels (APORT) shared between Analog Comparators, ADC, and IDAC
  - Up to 32 General Purpose I/O pins with output state retention and asynchronous interrupts
  - 8 Channel DMA Controller
  - 12 Channel Peripheral Reflex System (PRS)
  - 2 $\times$ 16-bit Timer/Counter
    - 3 + 4 Compare/Capture/PWM channels
  - 32-bit Real Time Counter and Calendar
  - 16-bit Low Energy Timer for waveform generation
  - 32-bit Ultra Low Energy Timer/Counter for periodic wake-up from any Energy Mode
  - 16-bit Pulse Counter with asynchronous operation
  - Watchdog Timer with dedicated RC oscillator @ 50nA
  - 2 $\times$ Universal Synchronous/Asynchronous Receiver/Transmitter (UART/SPI/SmartCard (ISO 7816)/IrDA/I<sup>2</sup>S)
  - Low Energy UART (LEUART<sup>™</sup>)
  - I<sup>2</sup>C interface with SMBus support and address recognition in EM3 Stop
- **Wide Operating Range**
  - 1.85 V to 3.8 V single power supply
  - Integrated DC-DC, down to 1.8 V output with up to 200 mA load current for system
  - -40 °C to 85 °C
- **QFN32 5x5 mm Package**
- **QFN48 7x7 mm Package**

## 2. Ordering Information

| Ordering Code           | Protocol Stack | Frequency Band<br>@ Max TX Power   | Encryption | Flash<br>(kB) | RAM<br>(kB) | GPIO | Package |
|-------------------------|----------------|--|------------|---------------|-------------|------|---------|
| EFR32FG1P133F256GM48-C0 | Proprietary    | <ul style="list-style-type: none"> <li>• 2.4 GHz @ 19.5 dBm</li> <li>• Sub-GHz @ 20 dBm</li> </ul> | Full       | 256           | 32          | 28   | QFN48   |
| EFR32FG1P133F128GM48-C0 | Proprietary    | <ul style="list-style-type: none"> <li>• 2.4 GHz @ 19.5 dBm</li> <li>• Sub-GHz @ 20 dBm</li> </ul> | Full       | 128           | 32          | 28   | QFN48   |
| EFR32FG1P133F64GM48-C0  | Proprietary    | <ul style="list-style-type: none"> <li>• 2.4 GHz @ 19.5 dBm</li> <li>• Sub-GHz @ 20 dBm</li> </ul> | Full       | 64            | 16          | 28   | QFN48   |
| EFR32FG1P132F256GM48-C0 | Proprietary    | 2.4 GHz @ 19.5 dBm   | Full       | 256           | 32          | 31   | QFN48   |
| EFR32FG1P132F128GM48-C0 | Proprietary    | 2.4 GHz @ 19.5 dBm   | Full       | 128           | 32          | 31   | QFN48   |
| EFR32FG1P132F64GM48-C0  | Proprietary    | 2.4 GHz @ 19.5 dBm   | Full       | 64            | 16          | 31   | QFN48   |
| EFR32FG1P132F256GM32-C0 | Proprietary    | 2.4 GHz @ 19.5 dBm   | Full       | 256           | 32          | 16   | QFN32   |
| EFR32FG1P132F128GM32-C0 | Proprietary    | 2.4 GHz @ 19.5 dBm   | Full       | 128           | 32          | 16   | QFN32   |
| EFR32FG1P132F64GM32-C0  | Proprietary    | 2.4 GHz @ 19.5 dBm   | Full       | 64            | 16          | 16   | QFN32   |
| EFR32FG1P131F256GM48-C0 | Proprietary    | Sub-GHz @ 20 dBm   | Full       | 256           | 32          | 32   | QFN48   |
| EFR32FG1P131F128GM48-C0 | Proprietary    | Sub-GHz @ 20 dBm   | Full       | 128           | 32          | 32   | QFN48   |
| EFR32FG1P131F64GM48-C0  | Proprietary    | Sub-GHz @ 20 dBm   | Full       | 64            | 16          | 32   | QFN48   |
| EFR32FG1P131F256GM32-C0 | Proprietary    | Sub-GHz @ 20 dBm   | Full       | 256           | 32          | 16   | QFN32   |
| EFR32FG1P131F128GM32-C0 | Proprietary    | Sub-GHz @ 20 dBm   | Full       | 128           | 32          | 16   | QFN32   |
| EFR32FG1P131F64GM32-C0  | Proprietary    | Sub-GHz @ 20 dBm   | Full       | 64            | 16          | 16   | QFN32   |
| EFR32FG1V132F256GM48-C0 | Proprietary    | 2.4 GHz @ 16.5 dBm   | AES only   | 256           | 32          | 31   | QFN48   |
| EFR32FG1V132F128GM48-C0 | Proprietary    | 2.4 GHz @ 16.5 dBm   | AES only   | 128           | 16          | 31   | QFN48   |
| EFR32FG1V132F64GM48-C0  | Proprietary    | 2.4 GHz @ 16.5 dBm   | AES only   | 64            | 16          | 31   | QFN48   |
| EFR32FG1V132F32GM48-C0  | Proprietary    | 2.4 GHz @ 16.5 dBm   | AES only   | 32            | 8           | 31   | QFN48   |
| EFR32FG1V132F256GM32-C0 | Proprietary    | 2.4 GHz @ 16.5 dBm   | AES only   | 256           | 32          | 16   | QFN32   |
| EFR32FG1V132F128GM32-C0 | Proprietary    | 2.4 GHz @ 16.5 dBm   | AES only   | 128           | 16          | 16   | QFN32   |
| EFR32FG1V132F64GM32-C0  | Proprietary    | 2.4 GHz @ 16.5 dBm   | AES only   | 64            | 16          | 16   | QFN32   |
| EFR32FG1V132F32GM32-C0  | Proprietary    | 2.4 GHz @ 16.5 dBm   | AES only   | 32            | 8           | 16   | QFN32   |
| EFR32FG1V131F256GM48-C0 | Proprietary    | Sub-GHz @ 16.5 dBm   | AES only   | 256           | 32          | 32   | QFN48   |
| EFR32FG1V131F128GM48-C0 | Proprietary    | Sub-GHz @ 16.5 dBm   | AES only   | 128           | 16          | 32   | QFN48   |
| EFR32FG1V131F64GM48-C0  | Proprietary    | Sub-GHz @ 16.5 dBm   | AES only   | 64            | 16          | 32   | QFN48   |
| EFR32FG1V131F32GM48-C0  | Proprietary    | Sub-GHz @ 16.5 dBm   | AES only   | 32            | 8           | 32   | QFN48   |
| EFR32FG1V131F256GM32-C0 | Proprietary    | Sub-GHz @ 16.5 dBm   | AES only   | 256           | 32          | 16   | QFN32   |
| EFR32FG1V131F128GM32-C0 | Proprietary    | Sub-GHz @ 16.5 dBm   | AES only   | 128           | 16          | 16   | QFN32   |
| EFR32FG1V131F64GM32-C0  | Proprietary    | Sub-GHz @ 16.5 dBm   | AES only   | 64            | 16          | 16   | QFN32   |
| EFR32FG1V131F32GM32-C0  | Proprietary    | Sub-GHz @ 16.5 dBm   | AES only   | 32            | 8           | 16   | QFN32   |

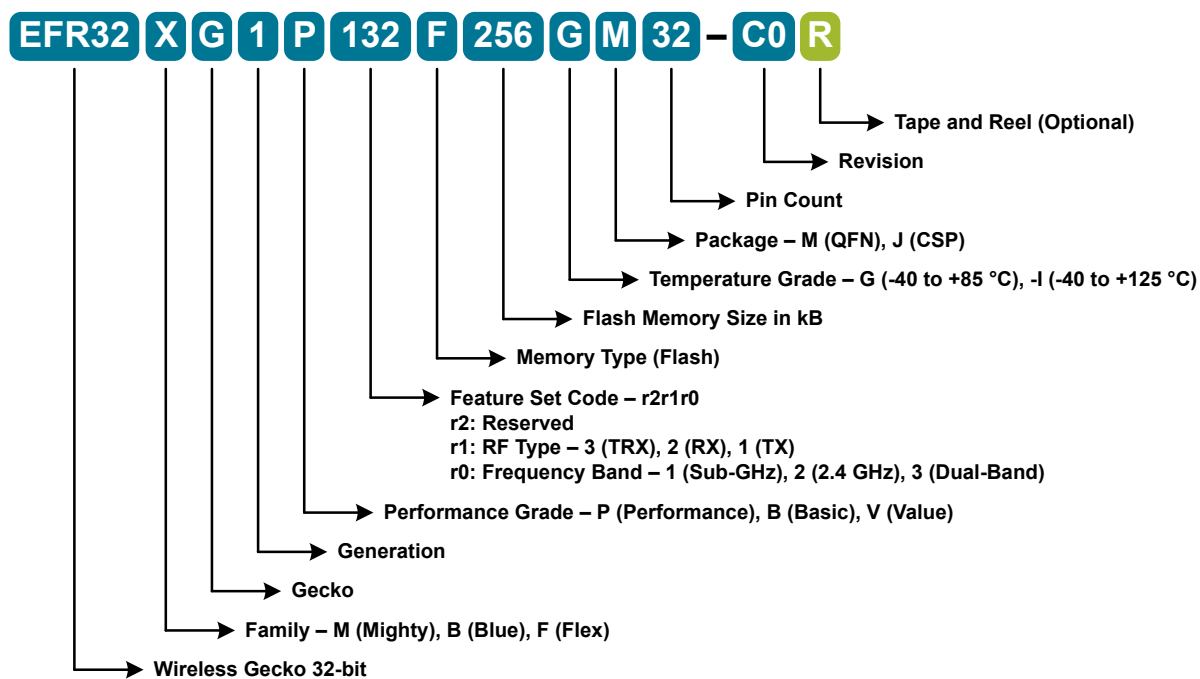


Figure 2.1. OPN Decoder

### 3. System Overview

#### 3.1 Introduction

The EFR32 product family combines an energy-friendly MCU with a highly integrated radio transceiver. The devices are well suited for any battery operated application as well as other systems requiring high performance and low energy consumption. This section gives a short introduction to the full radio and MCU system. The detailed functional description can be found in the EFR32 Reference Manual.

A block diagram of the EFR32FG1 family is shown in [Figure 3.1 Detailed EFR32FG1 Block Diagram on page 4](#). The diagram shows a superset of features available on the family, which vary by OPN. For more information about specific device features, consult [Ordering Information](#).

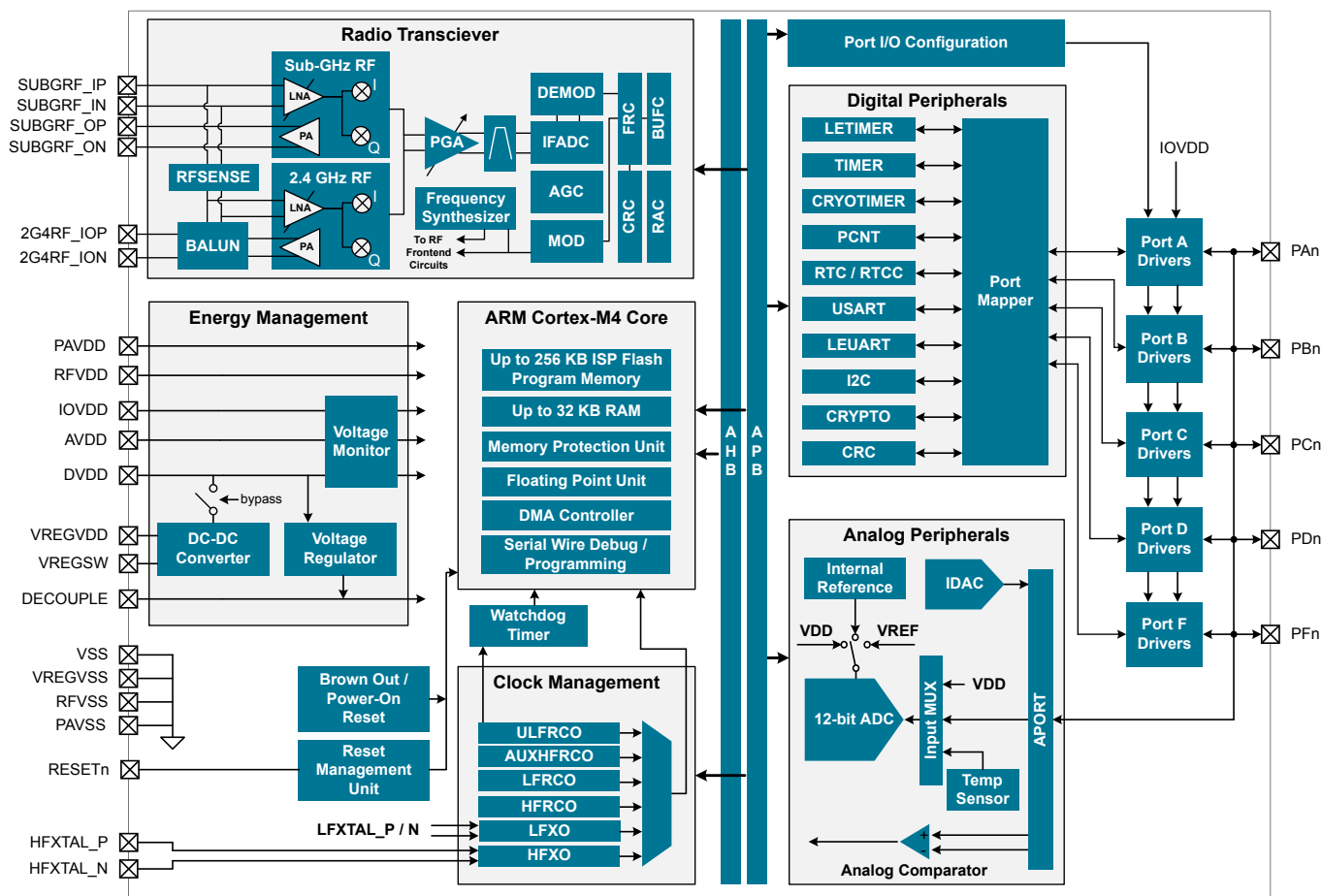


Figure 3.1. Detailed EFR32FG1 Block Diagram

#### 3.2 Radio

The Flex Gecko family features a radio transceiver supporting proprietary wireless protocols.

### 3.2.1 Antenna Interface

The EFR32FG1 family includes devices which support both single-band and dual-band RF communication over separate physical RF interfaces.

The 2.4 GHz antenna interface consists of two pins (2G4RF\_IOP and 2G4RF\_ION) that interface directly to the on-chip BALUN. The 2G4RF\_ION pin should be grounded externally.

The sub-GHz antenna interface consists of a differential transmit interface (pins SUBGRF\_OP and SUBGRF\_ON) and a differential receive interface (pins SUBGRF\_IP and SUBGRF\_IN).

The external components and power supply connections for the antenna interface typical applications are shown in the RF Matching Networks section.

### 3.2.2 Fractional-N Frequency Synthesizer

The EFR32FG1 contains a high performance, low phase noise, fully integrated fractional-N frequency synthesizer. The synthesizer is used in receive mode to generate the LO frequency used by the down-conversion mixer. It is also used in transmit mode to directly generate the modulated RF carrier.

The fractional-N architecture provides excellent phase noise performance combined with frequency resolution better than 100 Hz, with low energy consumption. The synthesizer has fast frequency settling which allows very short receiver and transmitter wake up times to optimize system energy consumption.

### 3.2.3 Receiver Architecture

The EFR32FG1 uses a low-IF receiver architecture, consisting of a Low-Noise Amplifier (LNA) followed by an I/Q down-conversion mixer, employing a crystal reference. The I/Q signals are further filtered and amplified before being sampled by the IF analog-to-digital converter (IFADC).

The IF frequency is configurable from 150 kHz to 1371 kHz. The IF can further be configured for high-side or low-side injection, providing flexibility with respect to known interferers at the image frequency.

The Automatic Gain Control (AGC) module adjusts the receiver gain to optimize performance and avoid saturation for excellent selectivity and blocking performance. The 2.4 GHz radio is calibrated at production to improve image rejection performance. The sub-GHz radio can be calibrated on-demand by the user for the desired frequency band.

Demodulation is performed in the digital domain. The demodulator performs configurable decimation and channel filtering to allow receive bandwidths ranging from 0.1 to 2530 kHz. High carrier frequency and baud rate offsets are tolerated by active estimation and compensation. Advanced features supporting high quality communication under adverse conditions include forward error correction by block and convolutional coding as well as Direct Sequence Spread Spectrum (DSSS).

A Received Signal Strength Indicator (RSSI) is available for signal quality metrics, for level-based proximity detection, and for RF channel access by Collision Avoidance (CA) or Listen Before Talk (LBT) algorithms. An RSSI capture value is associated with each received frame and the dynamic RSSI measurement can be monitored throughout reception.

The EFR32FG1 features integrated support for antenna diversity to improve link budget for 802.15.4 DSSS-OQPSK PHY configuration in the 2.4GHz band, using complementary control outputs to an external switch. Internal configurable hardware controls automatic switching between antennae during RF receive detection operations.

### 3.2.4 Transmitter Architecture

The EFR32FG1 uses a direct-conversion transmitter architecture. For constant envelope modulation formats, the modulator controls phase and frequency modulation in the frequency synthesizer. Transmit symbols or chips are optionally shaped by a digital shaping filter. The shaping filter is fully configurable, including the BT product, and can be used to implement Gaussian or Raised Cosine shaping.

Carrier Sense Multiple Access - Collision Avoidance (CSMA-CA) or Listen Before Talk (LBT) algorithms can be automatically timed by the EFR32FG1. These algorithms are typically defined by regulatory standards to improve inter-operability in a given bandwidth between devices that otherwise lack synchronized RF channel access.

### 3.2.5 Wake on Radio

The Wake on Radio feature allows flexible, autonomous RF sensing, qualification, and demodulation without required MCU activity, using a subsystem of the EFR32FG1 including the Radio Controller (RAC), Peripheral Reflex System (PRS), and Low Energy peripherals.

### 3.2.6 RFSENSE

The RFSENSE module generates a system wakeup interrupt upon detection of wideband RF energy at the antenna interface, providing true RF wakeup capabilities from low energy modes including EM2, EM3 and EM4.

RFSENSE triggers on a relatively strong RF signal and is available in the lowest energy modes, allowing exceptionally low energy consumption. RFSENSE does not demodulate or otherwise qualify the received signal, but software may respond to the wakeup event by enabling normal RF reception.

Various strategies for optimizing power consumption and system response time in presence of false alarms may be employed using available timer peripherals.

### 3.2.7 Flexible Frame Handling

EFR32FG1 has an extensive and flexible frame handling support for easy implementation of even complex communication protocols. The Frame Controller (FRC) supports all low level and timing critical tasks together with the Radio Controller and Modulator/Demodulator:

- Highly adjustable preamble length
- Up to 2 simultaneous synchronization words, each up to 32 bits and providing separate interrupts
- Frame disassembly and address matching (filtering) to accept or reject frames
- Automatic ACK frame assembly and transmission
- Fully flexible CRC generation and verification:
  - Multiple CRC values can be embedded in a single frame
  - 8, 16, 24 or 32-bit CRC value
  - Configurable CRC bit and byte ordering
- Selectable bit-ordering (least significant or most significant bit first)
- Optional data whitening
- Optional Forward Error Correction (FEC), including convolutional encoding / decoding and block encoding / decoding
- Half rate convolutional encoder and decoder with constraint lengths from 2 to 7 and optional puncturing
- Optional symbol interleaving, typically used in combination with FEC
- Symbol coding, such as Manchester or DSSS, or biphase space encoding using FEC hardware
- UART encoding over air, with start and stop bit insertion / removal
- Test mode support, such as modulated or unmodulated carrier output
- Received frame timestamping

### 3.2.8 Packet and State Trace

The EFR32FG1 Frame Controller has a packet and state trace unit that provides valuable information during the development phase. It features:

- Non-intrusive trace of transmit data, receive data and state information
- Data observability on a single-pin UART data output, or on a two-pin SPI data output
- Configurable data output bitrate / baudrate
- Multiplexed transmitted data, received data and state / meta information in a single serial data stream

### 3.2.9 Data Buffering

The EFR32FG1 features an advanced Radio Buffer Controller (BUFC) capable of handling up to 4 buffers of adjustable size from 64 bytes to 4096 bytes. Each buffer can be used for RX, TX or both. The buffer data is located in RAM, enabling zero-copy operations.

### 3.2.10 Radio Controller (RAC)

The Radio Controller controls the top level state of the radio subsystem in the EFR32FG1. It performs the following tasks:

- Precisely-timed control of enabling and disabling of the receiver and transmitter circuitry
- Run-time calibration of receiver, transmitter and frequency synthesizer
- Detailed frame transmission timing, including optional LBT or CSMA-CA

### 3.2.11 Random Number Generator

The Frame Controller (FRC) implements a random number generator that uses entropy gathered from noise in the RF receive chain. The data is suitable for use in cryptographic applications.

Output from the random number generator can be used either directly or as a seed or entropy source for software-based random number generator algorithms such as Fortuna.



### 3.3 Power

The EFR32FG1 has an Energy Management Unit (EMU) and efficient integrated regulators to generate internal supply voltages. Only a single external supply voltage is required, from which all internal voltages are created. An optional integrated DC-DC buck regulator can be utilized to further reduce the current consumption. The DC-DC regulator requires one external inductor and one external capacitor.

AVDD and VREGVDD need to be 1.85 V or higher for the MCU to operate across all conditions; however the rest of the system will operate down to 1.62 V, including the digital supply and I/O. This means that the device is fully compatible with 1.8 V components. Running from a sufficiently high supply, the device can use the DC-DC to regulate voltage not only for itself, but also for other PCB components, supplying up to a total of 200 mA.

#### 3.3.1 Energy Management Unit (EMU)

The Energy Management Unit manages transitions of energy modes in the device. Each energy mode defines which peripherals and features are available and the amount of current the device consumes. The EMU can also be used to turn off the power to unused RAM blocks, and it contains control registers for the dc-dc regulator and the Voltage Monitor (VMON). The VMON is used to monitor multiple supply voltages. It has multiple channels which can be programmed individually by the user to determine if a sensed supply has fallen below a chosen threshold.

#### 3.3.2 DC-DC Converter

The DC-DC buck converter covers a wide range of load currents and provides up to 90% efficiency in energy modes EM0, EM1, EM2 and EM3, and can supply up to 200 mA to the device and surrounding PCB components. Patented RF noise mitigation allows operation of the DC-DC converter without degrading sensitivity of radio components. Protection features include programmable current limiting, short-circuit protection, and dead-time protection. The DC-DC converter may also enter bypass mode when the input voltage is too low for efficient operation. In bypass mode, the DC-DC input supply is internally connected directly to its output through a low resistance switch. Bypass mode also supports in-rush current limiting to prevent input supply voltage droops due to excessive output current transients.

### 3.4 General Purpose Input/Output (GPIO)

EFR32FG1 has up to 32 General Purpose Input/Output pins. Each GPIO pin can be individually configured as either an output or input. More advanced configurations including open-drain, open-source, and glitch-filtering can be configured for each individual GPIO pin. The GPIO pins can be overridden by peripheral connections, like SPI communication. Each peripheral connection can be routed to several GPIO pins on the device. The input value of a GPIO pin can be routed through the Peripheral Reflex System to other peripherals. The GPIO subsystem supports asynchronous external pin interrupts.

### 3.5 Clocking

#### 3.5.1 Clock Management Unit (CMU)

The Clock Management Unit controls oscillators and clocks in the EFR32FG1. Individual enabling and disabling of clocks to all peripheral modules is performed by the CMU. The CMU also controls enabling and configuration of the oscillators. A high degree of flexibility allows software to optimize energy consumption in any specific application by minimizing power dissipation in unused peripherals and oscillators.

#### 3.5.2 Internal and External Oscillators

The EFR32FG1 supports two crystal oscillators and fully integrates four RC oscillators, listed below.

- A high frequency crystal oscillator (HFXO) with integrated load capacitors, tunable in small steps, provides a precise timing reference for the MCU. Crystal frequencies in the range from 38 to 40 MHz are supported. An external clock source such as a TCXO can also be applied to the HFXO input for improved accuracy over temperature.
- A 32.768 kHz crystal oscillator (LFXO) provides an accurate timing reference for low energy modes.
- An integrated high frequency RC oscillator (HFRCO) is available for the MCU system, when crystal accuracy is not required. The HFRCO employs fast startup at minimal energy consumption combined with a wide frequency range.
- An integrated auxiliary high frequency RC oscillator (AUXHFRCO) is available for timing the general-purpose ADC and the Serial Wire debug port with a wide frequency range.
- An integrated low frequency 32.768 kHz RC oscillator (LFRCO) can be used as a timing reference in low energy modes, when crystal accuracy is not required.
- An integrated ultra-low frequency 1 kHz RC oscillator (ULFRCO) is available to provide a timing reference at the lowest energy consumption in low energy modes.

## 3.6 Counters/Timers and PWM

### 3.6.1 Timer/Counter (TIMER)

TIMER peripherals keep track of timing, count events, generate PWM outputs and trigger timed actions in other peripherals through the PRS system. The core of each TIMER is a 16-bit counter with up to 4 compare/capture channels. Each channel is configurable in one of three modes. In capture mode, the counter state is stored in a buffer at a selected input event. In compare mode, the channel output reflects the comparison of the counter to a programmed threshold value. In PWM mode, the TIMER supports generation of pulse-width modulation (PWM) outputs of arbitrary waveforms defined by the sequence of values written to the compare registers, with optional dead-time insertion available in timer unit TIMER\_0 only.

### 3.6.2 Real Time Counter and Calendar (RTCC)

The Real Time Counter and Calendar (RTCC) is a 32-bit counter providing timekeeping in all energy modes. The RTCC includes a Binary Coded Decimal (BCD) calendar mode for easy time and date keeping. The RTCC can be clocked by any of the on-board oscillators with the exception of the AUXHFRCO, and it is capable of providing system wake-up at user defined instances. When receiving frames, the RTCC value can be used for timestamping. The RTCC includes 128 bytes of general purpose data retention, allowing easy and convenient data storage in all energy modes.

### 3.6.3 Low Energy Timer (LETIMER)

The unique LETIMER is a 16-bit timer that is available in energy mode EM2 Deep Sleep in addition to EM1 Sleep and EM0 Active. This allows it to be used for timing and output generation when most of the device is powered down, allowing simple tasks to be performed while the power consumption of the system is kept at an absolute minimum. The LETIMER can be used to output a variety of waveforms with minimal software intervention. The LETIMER is connected to the Real Time Counter and Calendar (RTCC), and can be configured to start counting on compare matches from the RTCC.

### 3.6.4 Ultra Low Power Wake-up Timer (CRYOTIMER)

The CRYOTIMER is a 32-bit counter that is capable of running in all energy modes. It can be clocked by either the 32.768 kHz crystal oscillator (LFXO), the 32.768 kHz RC oscillator (LFRCO), or the 1 kHz RC oscillator (ULFRCO). It can provide periodic Wakeup events and PRS signals which can be used to wake up peripherals from any energy mode. The CRYOTIMER provides a wide range of interrupt periods, facilitating flexible ultra-low energy operation.

### 3.6.5 Pulse Counter (PCNT)

The Pulse Counter (PCNT) peripheral can be used for counting pulses on a single input or to decode quadrature encoded inputs. The clock for PCNT is selectable from either an external source on pin PCTNn\_S0IN or from an internal timing reference, selectable from among any of the internal oscillators, except the AUXHFRCO. The module may operate in energy mode EM0 Active, EM1 Sleep, EM2 Deep Sleep, and EM3 Stop.

### 3.6.6 Watchdog Timer (WDOG)

The watchdog timer can act both as an independent watchdog or as a watchdog synchronous with the CPU clock. It has windowed monitoring capabilities, and can generate a reset or different interrupts depending on the failure mode of the system. The watchdog can also monitor autonomous systems driven by PRS.

## 3.7 Communications and Other Digital Peripherals

### 3.7.1 Universal Synchronous/Asynchronous Receiver/Transmitter (USART)

The Universal Synchronous/Asynchronous Receiver/Transmitter is a flexible serial I/O module. It supports full duplex asynchronous UART communication with hardware flow control as well as RS-485, SPI, MicroWire and 3-wire. It can also interface with devices supporting:

- ISO7816 SmartCards
- IrDA
- I<sup>2</sup>S

### 3.7.2 Low Energy Universal Asynchronous Receiver/Transmitter (LEUART)

The unique LEUART™ provides two-way UART communication on a strict power budget. Only a 32.768 kHz clock is needed to allow UART communication up to 9600 baud. The LEUART includes all necessary hardware to make asynchronous serial communication possible with a minimum of software intervention and energy consumption.

### 3.7.3 Inter-Integrated Circuit Interface (I<sup>2</sup>C)

The I<sup>2</sup>C module provides an interface between the MCU and a serial I<sup>2</sup>C bus. It is capable of acting as both a master and a slave and supports multi-master buses. Standard-mode, fast-mode and fast-mode plus speeds are supported, allowing transmission rates from 10 kbit/s up to 1 Mbit/s. Slave arbitration and timeouts are also available, allowing implementation of an SMBus-compliant system. The interface provided to software by the I<sup>2</sup>C module allows precise timing control of the transmission process and highly automated transfers. Automatic recognition of slave addresses is provided in active and low energy modes.

### 3.7.4 Peripheral Reflex System (PRS)

The Peripheral Reflex System provides a communication network between different peripheral modules without software involvement. Peripheral modules producing Reflex signals are called producers. The PRS routes Reflex signals from producers to consumer peripherals which in turn perform actions in response. Edge triggers and other functionality can be applied by the PRS. The PRS allows peripheral to act autonomously without waking the MCU core, saving power.

## 3.8 Security Features

### 3.8.1 GPCRC (General Purpose Cyclic Redundancy Check)

The GPCRC module implements a Cyclic Redundancy Check (CRC) function. It supports both 32-bit and 16-bit polynomials. The supported 32-bit polynomial is 0x04C11DB7 (IEEE 802.3), while the 16-bit polynomial can be programmed to any value, depending on the needs of the application.

### 3.8.2 Crypto Accelerator (CRYPTO)

The Crypto Accelerator is a fast and energy-efficient autonomous hardware encryption and decryption accelerator. EFR32 devices support various levels of hardware-accelerated encryption, depending on the part number. The Ordering Information Table specifies whether this part has **full** or **AES-only** crypto support. AES-only devices support AES encryption and decryption with 128- or 256-bit keys. Full crypto support adds ECC over both GF(P) and GF(2<sup>m</sup>), SHA-1 and SHA-2 (SHA-224 and SHA-256).

Supported block cipher modes of operation for AES include: ECB, CTR, CBC, PCBC, CFB, OFB, GCM, CBC-MAC, GMAC and CCM.

Supported ECC NIST recommended curves include P-192, P-224, P-256, K-163, K-233, B-163 and B-233.

The CRYPTO is tightly linked to the Radio Buffer Controller (BUFC) enabling fast and efficient autonomous cipher operations on data buffer content. It allows fast processing of GCM (AES), ECC and SHA with little CPU intervention. CRYPTO also provides trigger signals for DMA read and write operations.

## 3.9 Analog

### 3.9.1 Analog Port (APORT)

The Analog Port (APORT) is an analog interconnect matrix allowing access to analog modules ADC, ACMP, and IDAC on a flexible selection of pins. Each APORT bus consists of analog switches connected to a common wire. Since many clients can operate differentially, buses are grouped by X/Y pairs.

### 3.9.2 Analog Comparator (ACMP)

The Analog Comparator is used to compare the voltage of two analog inputs, with a digital output indicating which input voltage is higher. Inputs are selected from among internal references and external pins. The tradeoff between response time and current consumption is configurable by software. Two 6-bit reference dividers allow for a wide range of internally-programmable reference sources. The ACMP can also be used to monitor the supply voltage. An interrupt can be generated when the supply falls below or rises above the programmable threshold.

### 3.9.3 Analog to Digital Converter (ADC)

The ADC is a Successive Approximation Register (SAR) architecture, with a resolution of up to 12 bits at up to 1 MSamples/s. The output sample resolution is configurable and additional resolution is possible using integrated hardware for averaging over multiple samples. The ADC includes integrated voltage references and an integrated temperature sensor. Inputs are selectable from a wide range of sources, including pins configurable as either single-ended or differential.

### 3.9.4 Digital to Analog Current Converter (IDAC)

The Digital to Analog Current Converter can source or sink a configurable constant current. This current can be driven on an output pin or routed to the selected ADC input pin for capacitive sensing. The current is programmable between 0.05  $\mu\text{A}$  and 64  $\mu\text{A}$  with several ranges with various step sizes.

### 3.10 Reset Management Unit (RMU)

The RMU is responsible for handling reset of the EFR32FG1. A wide range of reset sources are available, including several power supply monitors, pin reset, software controlled reset, core lockup reset and watchdog reset.

### 3.11 Core and Memory

#### 3.11.1 Processor Core

The ARM Cortex-M processor includes a 32-bit RISC processor integrating the following features and tasks in the system:

- ARM Cortex-M4 RISC processor achieving 1.25 Dhrystone MIPS/MHz
- Memory Protection Unit (MPU) supporting up to 8 memory segments
- Up to 256 kB flash program memory
- Up to 32 kB RAM data memory
- Configuration and event handling of all modules
- 2-pin Serial-Wire debug interface

#### 3.11.2 Memory System Controller (MSC)

The Memory System Controller (MSC) is the program memory unit of the microcontroller. The flash memory is readable and writable from both the Cortex-M and DMA. The flash memory is divided into two blocks; the main block and the information block. Program code is normally written to the main block, whereas the information block is available for special user data and flash lock bits. There is also a read-only page in the information block containing system and device calibration data. Read and write operations are supported in energy modes EM0 Active and EM1 Sleep.

#### 3.11.3 Linked Direct Memory Access Controller (LDMA)

The Linked Direct Memory Access (LDMA) controller features 8 channels capable of performing memory operations independently of software. This reduces both energy consumption and software workload. The LDMA allows operations to be linked together and staged, enabling sophisticated operations to be implemented.

### 3.12 Memory Map

The EFR32FG1 memory map is shown in the figures below. RAM and flash sizes are for the largest memory configuration.

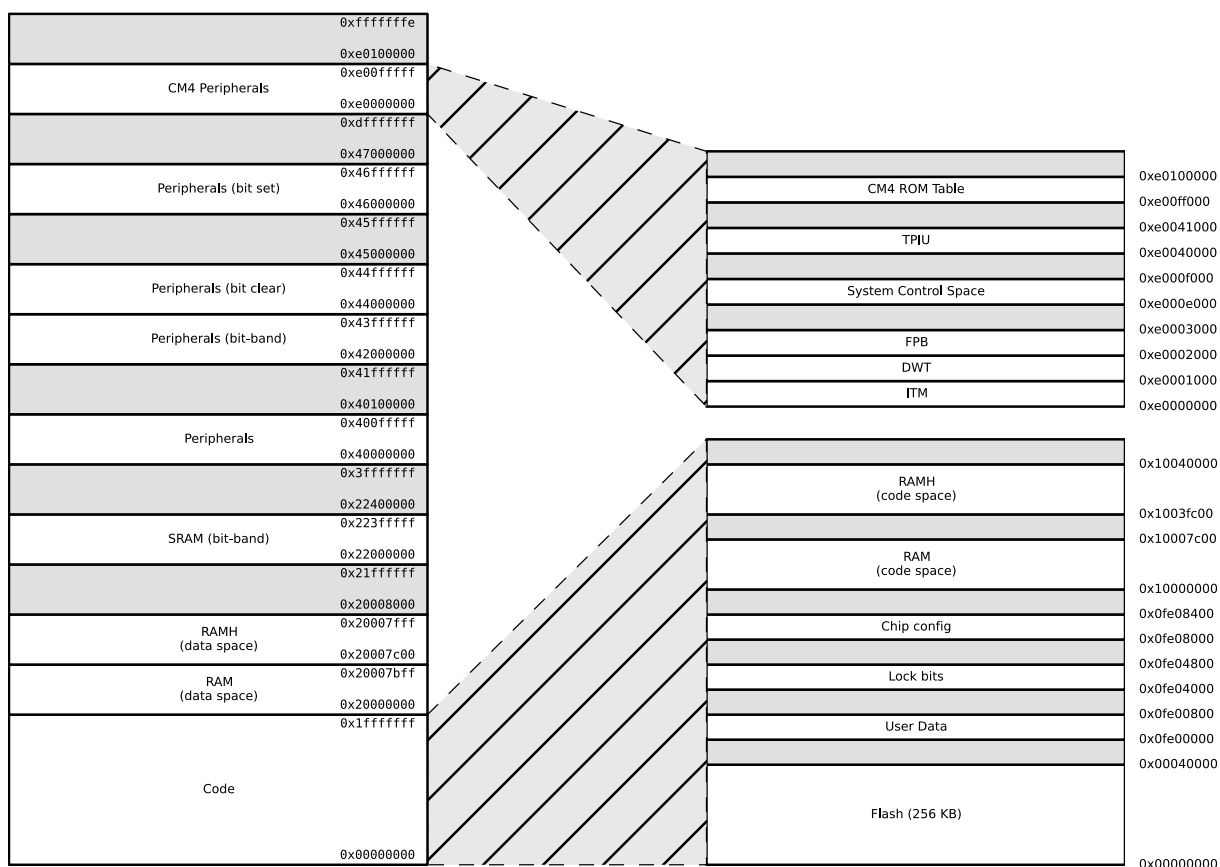


Figure 3.2. EFR32FG1 Memory Map — Core Peripherals and Code Space

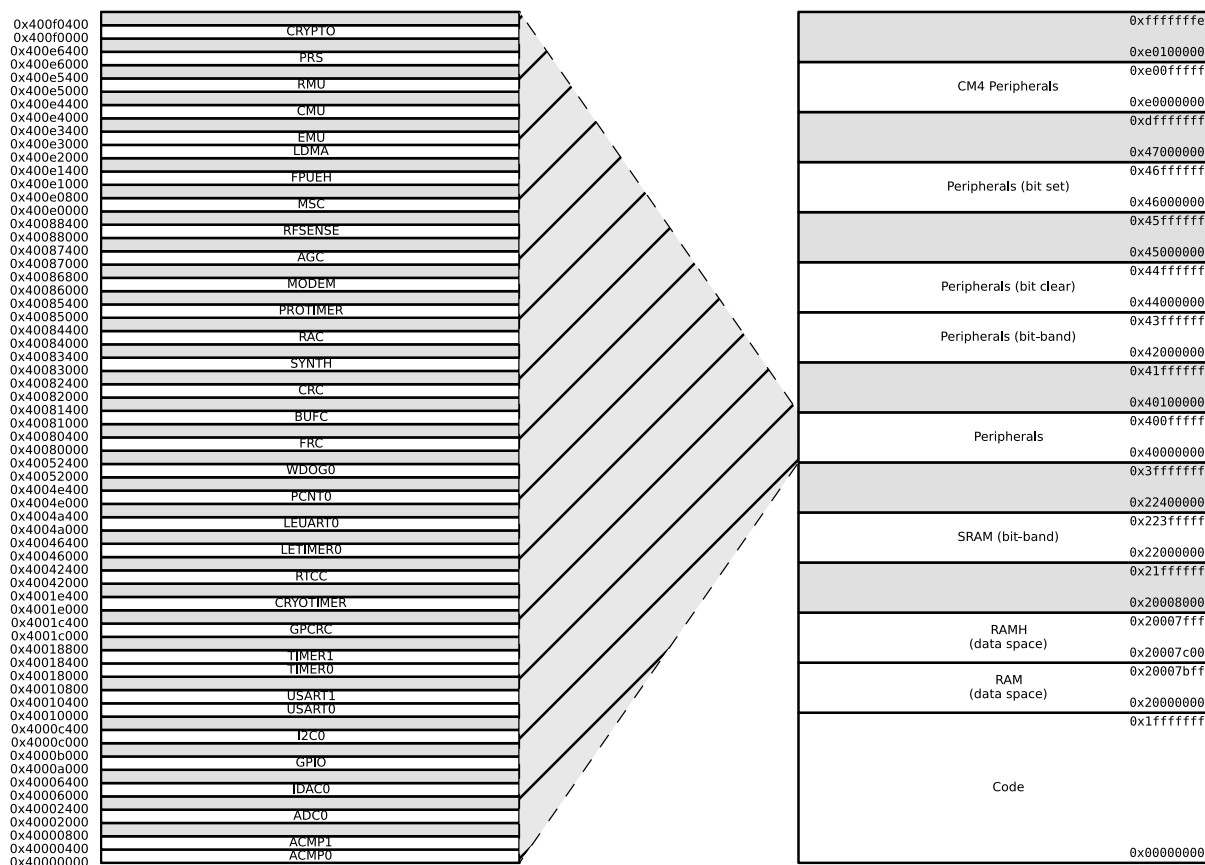


Figure 3.3. EFR32FG1 Memory Map — Peripherals

### 3.13 Configuration Summary

The features of the EFR32FG1 are a subset of the feature set described in the device reference manual. The table below describes device specific implementation of the features. Remaining modules support full configuration.

Table 3.1. Configuration Summary

| Module | Configuration                   | Pin Connections                 |
|--------|---------------------------------|---------------------------------|
| USART0 | IrDA SmartCard                  | US0_TX, US0_RX, US0_CLK, US0_CS |
| USART1 | IrDA I <sup>2</sup> S SmartCard | US1_TX, US1_RX, US1_CLK, US1_CS |
| TIMER0 | with DTI.                       | TIM0_CC[2:0], TIM0_CDTI[2:0]    |
| TIMER1 |                                 | TIM1_CC[3:0]                    |

## 4. Electrical Specifications

### 4.1 Electrical Characteristics

All electrical parameters in all tables are specified under the following conditions, unless stated otherwise:

- Typical values are based on  $T_{AMB}=25\text{ }^{\circ}\text{C}$  and  $V_{DD}=3.3\text{ V}$ , by production test and/or technology characterization.
- Radio performance numbers are measured in conducted mode, based on Silicon Laboratories reference designs using output power-specific external RF impedance-matching networks for interfacing to a  $50\ \Omega$  antenna.
- Minimum and maximum values represent the worst conditions across supply voltage, process variation, and an operating temperature of  $-40$  to  $+85\text{ }^{\circ}\text{C}$ , unless stated otherwise.

Refer to [Table 4.2 General Operating Conditions on page 17](#) for more details about operational supply and temperature limits.

### 4.1.1 Absolute Maximum Ratings

Stresses above those listed below may cause permanent damage to the device. This is a stress rating only and functional operation of the devices at those or any other conditions above those indicated in the operation listings of this specification is not implied. Exposure to maximum rating conditions for extended periods may affect device reliability. For more information on the available quality and reliability data, see the Quality and Reliability Monitor Report at <http://www.silabs.com/support/quality/pages/default.aspx>.

**Table 4.1. Absolute Maximum Ratings**

| Parameter  | Symbol                   | Test Condition | Min  | Typ | Max                      | Unit   |
|--|--------------------------|----------------|------|-----|--------------------------|--------|
| Storage temperature range  | T <sub>STG</sub>         |                | -50  | —   | 150                      | °C     |
| External main supply voltage   | V <sub>DDMAX</sub>       |                | 0    | —   | 3.8                      | V      |
| External main supply voltage ramp rate                                     | V <sub>DDRAMP</sub> MAX  |                | —    | —   | 1                        | V / μs |
| Voltage on any 5V tolerant GPIO pin <sup>1</sup>                           | V <sub>DIGPIN</sub>      |                | -0.3 | —   | Min of 5.25 and IOVDD +2 | V      |
| Voltage on non-5V tolerant GPIO pins                                       |                          |                | -0.3 | —   | IOVDD+0.3                | V      |
| Voltage on HFXO pins   | V <sub>HFXOPIN</sub>     |                | -0.3 | —   | 1.4                      | V      |
| Input RF level on pins 2G4RF_IOP and 2G4RF_ION                             | P <sub>RFMAX2G4</sub>    |                | —    | —   | 10                       | dBm    |
| Voltage differential between RF pins (2G4RF_IOP - 2G4RF_ION)               | V <sub>MAX2G4</sub>      |                | -50  | —   | 50                       | mV     |
| Absolute Voltage on RF pins 2G4RF_IOP and 2G4RF_ION                        | V <sub>MAXDIFF2G4</sub>  |                | -0.3 | —   | 3.3                      | V      |
| Input RF level on pins SUBGRF_IP and SUBGRF_IN                             | P <sub>RFMAXSUBG</sub>   |                | —    | —   | 10                       | dBm    |
| Voltage differential between RF pins (SUBGRF_IP - SUBGRF_IN)               | V <sub>MAXSUBG</sub>     |                | -50  | —   | 50                       | mV     |
| Absolute Voltage on RF pins SUBGRF_IP, SUBGRF_IN, SUBGRF_OP, and SUBGRF_ON | V <sub>MAXDIFFSUBG</sub> |                | -0.3 | —   | 3.3                      | V      |
| Total current into V <sub>DD</sub> power lines (source)                    | I <sub>VDDMAX</sub>      |                | —    | —   | TBD                      | mA     |
| Total current into V <sub>SS</sub> ground lines (sink)                     | I <sub>VSSMAX</sub>      |                | —    | —   | 200                      | mA     |
| Current per I/O pin (sink)   | I <sub>IOMAX</sub>       |                | —    | —   | 50                       | mA     |
| Current per I/O pin (source)   |                          |                | —    | —   | 50                       | mA     |
| Current for all I/O pins (sink)  | I <sub>IOALLMAX</sub>    |                | —    | —   | 200                      | mA     |
| Current for all I/O pins (source)  |                          |                | —    | —   | 200                      | mA     |
| Voltage difference between AVDD and VREGVDD                                | ΔV <sub>DD</sub>         |                | —    | —   | 0.3                      | V      |



| Parameter   | Symbol | Test Condition | Min | Typ | Max | Unit |
|---|--------|----------------|-----|-----|-----|------|
| <b>Note:</b><br>1. When a GPIO pin is routed to the analog module through the APORT, the maximum voltage = IOVDD. |        |                |     |     |     |      |

## 4.1.2 Operating Conditions

When assigning supply sources, the following requirements must be observed:

- VREGVDD must be the highest voltage in the system
- VREGVDD = AVDD
- DVDD ≤ AVDD
- IOVDD ≤ AVDD
- RFVDD ≤ AVDD
- PAVDD ≤ AVDD

### 4.1.2.1 General Operating Conditions

**Table 4.2. General Operating Conditions**

| Parameter  | Symbol               | Test Condition                                       | Min  | Typ  | Max                  | Unit |
|--|----------------------|--|------|------|----------------------|------|
| Operating temperature range                            | T <sub>OP</sub>      | -G temperature grade                                 | -40  | 25   | 85                   | °C   |
| AVDD Supply voltage <sup>1</sup>                       | V <sub>AVDD</sub>    |  | 1.85 | 3.3  | 3.8                  | V    |
| VREGVDD Operating supply voltage <sup>12</sup>         | V <sub>VREGVDD</sub> | DCDC in regulation                                   | 2.4  | 3.3  | 3.8                  | V    |
|  |                      | DCDC in bypass, 50mA load                            | 1.85 | 3.3  | 3.8                  | V    |
|  |                      | DCDC not in use. DVDD external-ly shorted to VREGVDD | 1.85 | 3.3  | 3.8                  | V    |
| VREGVDD Current  | I <sub>VREGVDD</sub> | DCDC in bypass                                       | —    | —    | 200                  | mA   |
| RFVDD Operating supply voltage                         | V <sub>RFVDD</sub>   |  | 1.62 | —    | V <sub>VREGVDD</sub> | V    |
| DVDD Operating supply voltage                          | V <sub>DVDD</sub>    |  | 1.62 | —    | V <sub>VREGVDD</sub> | V    |
| PAVDD Operating supply voltage                         | V <sub>PAVDD</sub>   |  | 1.62 | —    | V <sub>VREGVDD</sub> | V    |
|  |                      | V <sub>VREGVDD</sub> < 1.62 V                        | 0    | —    | V <sub>VREGVDD</sub> | V    |
| IOVDD Operating supply voltage                         | V <sub>IOVDD</sub>   |  | 1.62 | —    | V <sub>VREGVDD</sub> | V    |
| Difference between AVDD and VREGVDD, ABS(AVDD-VREGVDD) | dV <sub>DD</sub>     |  | —    | —    | 0.1                  | V    |
| HFCLK frequency  | f <sub>CORE</sub>    | 0 wait-states (MODE = WS0) <sup>3</sup>              | —    | —    | 26                   | MHz  |
|  |                      | 1 wait-states (MODE = WS1) <sup>3</sup>              | —    | 38.4 | 40                   | MHz  |

**Note:**

1. VREGVDD must be tied to AVDD. Both VREGVDD and AVDD minimum voltages must be satisfied for the part to operate.
2. The minimum voltage required in bypass mode is calculated using R<sub>BYP</sub> from the DCDC specification table. Requirements for other loads can be calculated as V<sub>DVDD\_min</sub>+I<sub>LOAD</sub> \* R<sub>BYP\_max</sub>
3. in MSC\_READCTRL register

4.1.3 Thermal Characteristics

Table 4.3. Thermal Characteristics

| Parameter          | Symbol              | Test Condition                                   | Min | Typ  | Max | Unit |
|--------------------|---------------------|--|-----|------|-----|------|
| Thermal Resistance | THETA <sub>JA</sub> | QFN32 Package, 2-Layer PCB, Air velocity = 0 m/s | —   | 79   | —   | °C/W |
|                    |                     | QFN32 Package, 2-Layer PCB, Air velocity = 1 m/s | —   | 62.2 | —   | °C/W |
|                    |                     | QFN32 Package, 2-Layer PCB, Air velocity = 2 m/s | —   | 54.1 | —   | °C/W |
|                    |                     | QFN32 Package, 4-Layer PCB, Air velocity = 0 m/s | —   | 32   | —   | °C/W |
|                    |                     | QFN32 Package, 4-Layer PCB, Air velocity = 1 m/s | —   | 28.1 | —   | °C/W |
|                    |                     | QFN32 Package, 4-Layer PCB, Air velocity = 2 m/s | —   | 26.9 | —   | °C/W |
|                    |                     | QFN48 Package, 2-Layer PCB, Air velocity = 0 m/s | —   | 64.5 | —   | °C/W |
|                    |                     | QFN48 Package, 2-Layer PCB, Air velocity = 1 m/s | —   | 51.6 | —   | °C/W |
|                    |                     | QFN48 Package, 2-Layer PCB, Air velocity = 2 m/s | —   | 47.7 | —   | °C/W |
|                    |                     | QFN48 Package, 4-Layer PCB, Air velocity = 0 m/s | —   | 26.2 | —   | °C/W |
|                    |                     | QFN48 Package, 4-Layer PCB, Air velocity = 1 m/s | —   | 23.1 | —   | °C/W |
|                    |                     | QFN48 Package, 4-Layer PCB, Air velocity = 2 m/s | —   | 22.1 | —   | °C/W |

#### 4.1.4 DC-DC Converter

Test conditions:  $L_{DCDC}=4.7\ \mu\text{H}$  (Murata LQH3NPN4R7MM0L),  $C_{DCDC}=1.0\ \mu\text{F}$  (Murata GRM188R71A105KA61D),  $V_{DCDC\_I}=3.3\ \text{V}$ ,  $V_{DCDC\_O}=1.8\ \text{V}$ ,  $I_{DCDC\_LOAD}=50\ \text{mA}$ , Heavy Drive configuration,  $F_{DCDC\_LN}=7\ \text{MHz}$ , unless otherwise indicated.

**Table 4.4. DC-DC Converter**

| Parameter                                      | Symbol          | Test Condition  | Min  | Typ | Max                | Unit          |
|--|-----------------|---|------|-----|--------------------|---------------|
| Input voltage range                            | $V_{DCDC\_I}$   | Bypass mode, $I_{DCDC\_LOAD} = 50\ \text{mA}$   | 1.85 | —   | $V_{VREGVDD\_MAX}$ | V             |
|  |                 | Low noise (LN) mode, 1.8 V output, $I_{DCDC\_LOAD} = 100\ \text{mA}$ , or Low power (LP) mode, 1.8 V output, $I_{DCDC\_LOAD} = 10\ \text{mA}$ | 2.4  | —   | $V_{VREGVDD\_MAX}$ | V             |
|  |                 | Low noise (LN) mode, 1.8 V output, $I_{DCDC\_LOAD} = 200\ \text{mA}$  | 2.6  | —   | $V_{VREGVDD\_MAX}$ | V             |
| Output voltage programmable range <sup>1</sup> | $V_{DCDC\_O}$   |   | 1.8  | —   | $V_{VREGVDD}$      | V             |
| Regulation DC Accuracy                         | $ACC_{DC}$      | Low noise (LN) mode, 1.8 V target output  | TBD  | —   | TBD                | mV            |
|  |                 | Low power (LP) mode, $LPCMPBIAS^2 = 0$ , 1.8 V target output, $I_{DCDC\_LOAD} = 75\ \mu\text{A}$  | TBD  | —   | TBD                | mV            |
|  |                 | Low power (LP) mode, $LPCMPBIAS^2 = 3$ , 1.8 V target output, $I_{DCDC\_LOAD} = 10\ \text{mA}$  | TBD  | —   | TBD                | mV            |
| Steady-state output ripple                     | $V_R$           | Radio disabled.   | —    | 3   | —                  | mVpp          |
| Output voltage under/overshoot                 | $V_{OV}$        | CCM Mode ( $LNFORCECCM^2 = 1$ ), Load changes between 0 mA and 100 mA   | —    | —   | 150                | mV            |
|  |                 | DCM Mode ( $LNFORCECCM^2 = 0$ ), Load changes between 0 mA and 10 mA  | —    | —   | 150                | mV            |
| DC line regulation                             | $V_{REG}$       | Input changes between $V_{VREGVDD\_MAX}$ and 2.4 V  | —    | 0.1 | —                  | %             |
| DC load regulation                             | $I_{REG}$       | Load changes between 0 mA and 100 mA in CCM mode  | —    | 0.1 | —                  | %             |
| Max load current                               | $I_{LOAD\_MAX}$ | Low noise (LN) mode, Heavy Drive <sup>3</sup>   | —    | —   | 200                | mA            |
|  |                 | Low noise (LN) mode, Medium Drive <sup>3</sup>  | —    | —   | 100                | mA            |
|  |                 | Low noise (LN) mode, Light Drive <sup>3</sup>   | —    | —   | 50                 | mA            |
|  |                 | Low power (LP) mode, $LPCMPBIAS^2 = 0$  | —    | —   | 75                 | $\mu\text{A}$ |
|  |                 | Low power (LP) mode, $LPCMPBIAS^2 = 3$  | —    | —   | 10                 | mA            |
| DCDC nominal output capacitor                  | $C_{DCDC}$      | 25% tolerance   | 1    | 1   | TBD                | $\mu\text{F}$ |

| Parameter                    | Symbol            | Test Condition | Min | Typ | Max | Unit |
|------------------------------|-------------------|----------------|-----|-----|-----|------|
| DCDC nominal output inductor | L <sub>DCDC</sub> | 20% tolerance  | 4.7 | 4.7 | 4.7 | μH   |
| Resistance in Bypass mode    | R <sub>BYP</sub>  |                | —   | 1.2 | 2.5 | Ω    |

**Note:**

1. Due to internal dropout, the DC-DC output will never be able to reach its input voltage,  $V_{VREGVDD}$
2. In EMU\_DCDCMISCCTRL register
3. Drive levels are defined by configuration of the PFETCNT and NFETCNT registers. Light Drive: PFETCNT=NFETCNT=3; Medium Drive: PFETCNT=NFETCNT=7; Heavy Drive: PFETCNT=NFETCNT=15.

#### 4.1.5 Current Consumption

##### 4.1.5.1 Current Consumption 3.3 V without DC-DC Converter

Unless otherwise indicated, typical conditions are: VREGVDD = AVDD = DVDD = RFVDD = PAVDD= 3.3 V. T<sub>OP</sub> = 25 °C. EMU\_PWRCFG\_PWRCG=NODCDC. EMU\_DCDCCTRL\_DCDCMODE=BYPASS. Minimum and maximum values in this table represent the worst conditions across supply voltage and process variation at T<sub>OP</sub> = 25 °C. See [Figure 5.1 EFR32FG1 Typical Application Circuit: Direct Supply Configuration without DC-DC converter on page 92](#).

**Table 4.5. Current Consumption 3.3V without DC/DC**

| Parameter  | Symbol              | Test Condition   | Min | Typ  | Max  | Unit   |
|--|---------------------|--|-----|------|------|--------|
| Current consumption in EM0 Active mode with all peripherals disabled | I <sub>ACTIVE</sub> | 38.4 MHz crystal, CPU running while loop from flash <sup>1</sup> | —   | 130  | —    | μA/MHz |
|  |                     | 38 MHz HFRCO, CPU running Prime from flash                       | —   | 88   | —    | μA/MHz |
|  |                     | 38 MHz HFRCO, CPU running while loop from flash                  | —   | 100  | 105  | μA/MHz |
|  |                     | 38 MHz HFRCO, CPU running CoreMark from flash                    | —   | 112  | —    | μA/MHz |
|  |                     | 26 MHz HFRCO, CPU running while loop from flash                  | —   | 102  | 106  | μA/MHz |
|  |                     | 1 MHz HFRCO, CPU running while loop from flash                   | —   | 222  | 350  | μA/MHz |
| Current consumption in EM1 Sleep mode with all peripherals disabled  | I <sub>EM1</sub>    | 38.4 MHz crystal <sup>1</sup>                                    | —   | 65   | —    | μA/MHz |
|  |                     | 38 MHz HFRCO   | —   | 35   | 38   | μA/MHz |
|  |                     | 26 MHz HFRCO   | —   | 37   | 41   | μA/MHz |
|  |                     | 1 MHz HFRCO  | —   | 157  | 275  | μA/MHz |
| Current consumption in EM2 Deep Sleep mode.                          | I <sub>EM2</sub>    | Full RAM retention and RTCC running from LFXO                    | —   | 3.3  | —    | μA     |
|  |                     | 4 kB RAM retention and RTCC running from LFRCO                   | —   | 3    | 6.3  | μA     |
| Current consumption in EM3 Stop mode                                 | I <sub>EM3</sub>    | Full RAM retention and CRYO-TIMER running from ULFRCO            | —   | 2.8  | 6    | μA     |
| Current consumption in EM4H Hibernate mode                           | I <sub>EM4</sub>    | 128 byte RAM retention, RTCC running from LFXO                   | —   | 1.1  | —    | μA     |
|  |                     | 128 byte RAM retention, CRYO-TIMER running from ULFRCO           | —   | 0.65 | —    | μA     |
|  |                     | 128 byte RAM retention, no RTCC                                  | —   | 0.65 | 1.3  | μA     |
| Current consumption in EM4S Shutoff mode                             | I <sub>EM4S</sub>   | no RAM retention, no RTCC  | —   | 0.04 | 0.11 | μA     |
| <b>Note:</b><br>1. CMU_HFXOCTRL_LOWPOWER=0                           |                     |  |     |      |      |        |

#### 4.1.5.2 Current Consumption 3.3 V using DC-DC Converter

Unless otherwise indicated, typical conditions are: VREGVDD = AVDD = IOVDD = 3.3 V, DVDD = RFVDD = PAVDD= 1.8 V DC-DC output. T<sub>OP</sub> = 25 °C. Minimum and maximum values in this table represent the worst conditions across supply voltage and process variation at T<sub>OP</sub> = 25 °C. See [Figure 5.2 EFR32FG1 Typical Application Circuit: Configuration with DC-DC converter \(PAVDD from VDCDC\)](#) on page 92.

**Table 4.6. Current Consumption 3.3V with DC-DC**

| Parameter   | Symbol              | Test Condition   | Min | Typ  | Max | Unit   |
|---|---------------------|--|-----|------|-----|--------|
| Current consumption in EM0 Active mode with all peripherals disabled, DCDC in Low Noise DCM mode <sup>1</sup> . | I <sub>ACTIVE</sub> | 38.4 MHz crystal, CPU running while loop from flash <sup>2</sup> | —   | 88   | —   | µA/MHz |
|   |                     | 38 MHz HFRCO, CPU running Prime from flash                       | —   | 63   | —   | µA/MHz |
|   |                     | 38 MHz HFRCO, CPU running while loop from flash                  | —   | 71   | —   | µA/MHz |
|   |                     | 38 MHz HFRCO, CPU running CoreMark from flash                    | —   | 78   | —   | µA/MHz |
|   |                     | 26 MHz HFRCO, CPU running while loop from flash                  | —   | 76   | —   | µA/MHz |
| Current consumption in EM0 Active mode with all peripherals disabled, DCDC in Low Noise CCM mode <sup>3</sup> . | I <sub>ACTIVE</sub> | 38.4 MHz crystal, CPU running while loop from flash <sup>2</sup> | —   | 98   | —   | µA/MHz |
|   |                     | 38 MHz HFRCO, CPU running Prime from flash                       | —   | 75   | —   | µA/MHz |
|   |                     | 38 MHz HFRCO, CPU running while loop from flash                  | —   | 81   | —   | µA/MHz |
|   |                     | 38 MHz HFRCO, CPU running CoreMark from flash                    | —   | 88   | —   | µA/MHz |
|   |                     | 26 MHz HFRCO, CPU running while loop from flash                  | —   | 94   | —   | µA/MHz |
| Current consumption in EM1 Sleep mode with all peripherals disabled, DCDC in Low Noise DCM mode <sup>1</sup> .  | I <sub>EM1</sub>    | 38.4 MHz crystal <sup>2</sup>                                    | —   | 49   | —   | µA/MHz |
|   |                     | 38 MHz HFRCO   | —   | 32   | —   | µA/MHz |
|   |                     | 26 MHz HFRCO   | —   | 38   | —   | µA/MHz |
| Current consumption in EM1 Sleep mode with all peripherals disabled, DCDC in Low Noise CCM mode <sup>3</sup> .  | I <sub>EM1</sub>    | 38.4 MHz crystal <sup>2</sup>                                    | —   | 61   | —   | µA/MHz |
|   |                     | 38 MHz HFRCO   | —   | 45   | —   | µA/MHz |
|   |                     | 26 MHz HFRCO   | —   | 58   | —   | µA/MHz |
| Current consumption in EM2 Deep Sleep mode. DCDC in Low Power mode <sup>4</sup> .                               | I <sub>EM2</sub>    | Full RAM retention and RTCC running from LFXO                    | —   | 1.4  | —   | µA     |
|   |                     | 4 kB RAM retention and RTCC running from LFRCO                   | —   | 1.4  | —   | µA     |
| Current consumption in EM3 Stop mode  | I <sub>EM3</sub>    | Full RAM retention and CRYO-TIMER running from ULFRCO            | —   | 1.1  | —   | µA     |
| Current consumption in EM4H Hibernate mode  | I <sub>EM4</sub>    | 128 byte RAM retention, RTCC running from LFXO                   | —   | 0.86 | —   | µA     |
|   |                     | 128 byte RAM retention, CRYO-TIMER running from ULFRCO           | —   | 0.58 | —   | µA     |
|   |                     | 128 byte RAM retention, no RTCC                                  | —   | 0.58 | —   | µA     |

| Parameter                                | Symbol     | Test Condition            | Min | Typ  | Max | Unit          |
|--|------------|---------------------------|-----|------|-----|---------------|
| Current consumption in EM4S Shutoff mode | $I_{EM4S}$ | no RAM retention, no RTCC | —   | 0.04 | —   | $\mu\text{A}$ |

**Note:**

1. DCDC Low Noise DCM Mode = Light Drive (PFETCNT=NFETCNT=3), F=3.0 MHz (RCOBAND=0), ANASW=DVDD
2. CMU\_HFXOCTRL\_LOWPOWER=0
3. DCDC Low Noise CCM Mode = Light Drive (PFETCNT=NFETCNT=3), F=6.4 MHz (RCOBAND=4), ANASW=DVDD
4. DCDC Low Power Mode = Medium Drive (PFETCNT=NFETCNT=7), LPOSCDIV=1, LPBIAS=3, LPCILIMSEL=1, ANASW=DVDD



#### 4.1.5.3 Current Consumption 1.85 V without DC-DC Converter

Unless otherwise indicated, typical conditions are: VREGVDD = AVDD = DVDD = RFVDD = PAVDD= 1.85 V. T<sub>OP</sub> = 25 °C. EMU\_PWRCFG\_PWRCG=NODCDC. EMU\_DCDCCTRL\_DCDCMODE=BYPASS. Minimum and maximum values in this table represent the worst conditions across supply voltage and process variation at T<sub>OP</sub> = 25 °C. See [Figure 5.1 EFR32FG1 Typical Application Circuit: Direct Supply Configuration without DC-DC converter on page 92](#).

**Table 4.7. Current Consumption 1.85V without DC/DC**

| Parameter  | Symbol              | Test Condition   | Min | Typ  | Max | Unit   |
|--|---------------------|--|-----|------|-----|--------|
| Current consumption in EM0 Active mode with all peripherals disabled | I <sub>ACTIVE</sub> | 38.4 MHz crystal, CPU running while loop from flash <sup>1</sup> | —   | 131  | —   | µA/MHz |
|  |                     | 38 MHz HFRCO, CPU running Prime from flash                       | —   | 88   | —   | µA/MHz |
|  |                     | 38 MHz HFRCO, CPU running while loop from flash                  | —   | 100  | —   | µA/MHz |
|  |                     | 38 MHz HFRCO, CPU running CoreMark from flash                    | —   | 112  | —   | µA/MHz |
|  |                     | 26 MHz HFRCO, CPU running while loop from flash                  | —   | 102  | —   | µA/MHz |
|  |                     | 1 MHz HFRCO, CPU running while loop from flash                   | —   | 220  | —   | µA/MHz |
| Current consumption in EM1 Sleep mode with all peripherals disabled  | I <sub>EM1</sub>    | 38.4 MHz crystal <sup>1</sup>                                    | —   | 65   | —   | µA/MHz |
|  |                     | 38 MHz HFRCO   | —   | 35   | —   | µA/MHz |
|  |                     | 26 MHz HFRCO   | —   | 37   | —   | µA/MHz |
|  |                     | 1 MHz HFRCO  | —   | 154  | —   | µA/MHz |
| Current consumption in EM2 Deep Sleep mode                           | I <sub>EM2</sub>    | Full RAM retention and RTCC running from LFXO                    | —   | 3.2  | —   | µA     |
|  |                     | 4 kB RAM retention and RTCC running from LFRCO                   | —   | 2.8  | —   | µA     |
| Current consumption in EM3 Stop mode                                 | I <sub>EM3</sub>    | Full RAM retention and CRYO-TIMER running from ULFRCO            | —   | 2.7  | —   | µA     |
| Current consumption in EM4H Hibernate mode                           | I <sub>EM4</sub>    | 128 byte RAM retention, RTCC running from LFXO                   | —   | 1    | —   | µA     |
|  |                     | 128 byte RAM retention, CRYO-TIMER running from ULFRCO           | —   | 0.62 | —   | µA     |
|  |                     | 128 byte RAM retention, no RTCC                                  | —   | 0.62 | —   | µA     |
| Current consumption in EM4S Shutoff mode                             | I <sub>EM4S</sub>   | No RAM retention, no RTCC  | —   | 0.02 | —   | µA     |

**Note:**

1. CMU\_HFXOCTRL\_LOWPOWER=0

#### 4.1.5.4 Current Consumption Using Radio

Unless otherwise indicated, typical conditions are: VREGVDD = AVDD = IOVDD = 3.3 V, DVDD = RFVDD = PAVDD. T<sub>OP</sub> = 25 °C. Minimum and maximum values in this table represent the worst conditions across supply voltage and process variation at T<sub>OP</sub> = 25 °C. See [Figure 5.2 EFR32FG1 Typical Application Circuit: Configuration with DC-DC converter \(PAVDD from VDCDC\)](#) on page 92 or [Figure 5.1 EFR32FG1 Typical Application Circuit: Direct Supply Configuration without DC-DC converter](#) on page 92.

**Table 4.8. Current Consumption Using Radio 3.3 V with DC-DC**

| Parameter  | Symbol          | Test Condition   | Min | Typ | Max | Unit |
|--|-----------------|--|-----|-----|-----|------|
| Current consumption in receive mode, active packet reception (MCU in EM1 @ 38.4 MHz, peripheral clocks disabled) | I <sub>RX</sub> | 500 kbit/s, 2GFSK, F = 915MHz , Radio clock prescaled by 4   | —   | 8.1 | 10  | mA   |
|  |                 | 38.4 kbit/s, 2GFSK, F = 868 MHz , Radio clock prescaled by 4 | —   | 8.1 | 10  | mA   |
|  |                 | 38.4 kbit/s, 2GFSK, F = 490 MHz , Radio clock prescaled by 4 | —   | 7.9 | 10  | mA   |
|  |                 | 50 kbit/s, 2GFSK, F = 433 MHz , Radio clock prescaled by 4   | —   | 7.7 | 10  | mA   |
|  |                 | 38.4 kbit/s, 2GFSK, F = 315MHz , Radio clock prescaled by 4  | —   | 7.9 | 10  | mA   |
|  |                 | 38.4 kbit/s, 2GFSK, F = 169MHz , Radio clock prescaled by 4  | —   | 7.6 | 10  | mA   |
|  |                 | 1 Mbit/s, 2GFSK, F = 2.4 GHz, Radio clock prescaled by 4     | —   | 8.7 | —   | mA   |

| Parameter  | Symbol               | Test Condition  | Min | Typ   | Max   | Unit |
|--|----------------------|---|-----|-------|-------|------|
| Current consumption in transmit mode (MCU in EM1 @ 38.4 MHz, peripheral clocks disabled) | I <sub>TX</sub>      | F = 915 MHz, CW, 20 dBm match, PAVDD connected directly to external 3.3V supply   | —   | 80.2  | 104   | mA   |
|  |                      | F = 915 MHz, CW, 14 dBm match, PAVDD connected to DCDC output                     | —   | 35.5  | 40.9  | mA   |
|  |                      | F = 868 MHz, CW, 20 dBm match, PAVDD connected directly to external 3.3V supply   | —   | 84.9  | 114   | mA   |
|  |                      | F = 868 MHz, CW, 14 dBm match, PAVDD connected to DCDC output                     | —   | 34.5  | 42    | mA   |
|  |                      | F = 490 MHz, CW, 20 dBm match, PAVDD connected directly to external 3.3V supply   | —   | 82.8  | 112   | mA   |
|  |                      | F = 433 MHz, CW, 14 dBm match, PAVDD connected to DCDC output                     | —   | 32.3  | 37.8  | mA   |
|  |                      | F = 433 MHz, CW, 10 dBm match, PAVDD connected to DCDC output                     | —   | 19.5  | 22.1  | mA   |
|  |                      | F = 315 MHz, CW, 14 dBm match, PAVDD connected to DCDC output                     | —   | 32.5  | 39.4  | mA   |
|  |                      | F = 169 MHz, CW, 20 dBm match, PAVDD connected directly to external 3.3V supply   | —   | 80.2  | 106.9 | mA   |
|  |                      | F = 2.4 GHz, CW, 0 dBm match, Radio clock prescaled by 3                          | —   | 8.2   | —     | mA   |
|  |                      | F = 2.4 GHz, CW, 3 dBm match  | —   | 16.5  | —     | mA   |
|  |                      | F = 2.4 GHz, CW, 8 dBm match  | —   | 23.3  | —     | mA   |
|  |                      | F = 2.4 GHz, CW, 10.5 dBm match   | —   | 32.7  | —     | mA   |
|  |                      | F = 2.4 GHz, CW, 16.5 dBm match, PAVDD connected directly to external 3.3V supply | —   | 83.9  | —     | mA   |
|  |                      | F = 2.4 GHz, CW, 19.5 dBm match, PAVDD connected directly to external 3.3V supply | —   | 126.7 | —     | mA   |
| RFSENSE current consumption  | I <sub>RFSENSE</sub> |   | —   | 51    | —     | nA   |

#### 4.1.6 Wake up times

**Table 4.9. Wake up times**

| Parameter  | Symbol         | Test Condition            | Min | Typ  | Max | Unit          |
|--|----------------|---------------------------|-----|------|-----|---------------|
| Wake up from EM2 Deep Sleep  | $t_{EM2\_WU}$  | Code execution from flash | —   | 10.7 | —   | $\mu\text{s}$ |
|  |                | Code execution from RAM   | —   | 3    | —   | $\mu\text{s}$ |
| Wakeup time from EM1 Sleep   | $t_{EM1\_WU}$  | Executing from flash      | —   | 3    | —   | AHB Clocks    |
|  |                | Executing from RAM        | —   | 3    | —   | AHB Clocks    |
| Wake up from EM3 Stop  | $t_{EM3\_WU}$  | Executing from flash      | —   | 10.7 | —   | $\mu\text{s}$ |
|  |                | Executing from RAM        | —   | 3    | —   | $\mu\text{s}$ |
| Wake up from EM4H Hibernate <sup>1</sup>   | $t_{EM4H\_WU}$ | Executing from flash      | —   | 60   | —   | $\mu\text{s}$ |
| Wake up from EM4S Shut-off <sup>1</sup>  | $t_{EM4S\_WU}$ |                           | —   | 290  | —   | $\mu\text{s}$ |
| <b>Note:</b>   |                |                           |     |      |     |               |
| 1. Time from wakeup request until first instruction is executed. Wakeup results in device reset. |                |                           |     |      |     |               |

#### 4.1.7 Brown Out Detector

**Table 4.10. Brown Out Detector**

| Parameter           | Symbol               | Test Condition                           | Min  | Typ | Max  | Unit          |
|---------------------|----------------------|--|------|-----|------|---------------|
| DVDD BOD threshold  | $V_{DVDDBOD}$        | DVDD rising                              | —    | —   | 1.62 | V             |
|                     |                      | DVDD falling                             | 1.35 | —   | —    | V             |
| DVDD BOD hysteresis | $V_{DVDDBOD\_HYST}$  |  | —    | 24  | —    | mV            |
| DVDD response time  | $t_{DVDDBOD\_DELAY}$ | Supply drops at 0.1V/ $\mu\text{s}$ rate | —    | 2.4 | —    | $\mu\text{s}$ |
| AVDD BOD threshold  | $V_{AVDDBOD}$        | AVDD rising                              | —    | —   | 1.85 | V             |
|                     |                      | AVDD falling                             | 1.62 | —   | —    | V             |
| AVDD BOD hysteresis | $V_{AVDDBOD\_HYST}$  |  | —    | 21  | —    | mV            |
| AVDD response time  | $t_{AVDDBOD\_DELAY}$ | Supply drops at 0.1V/ $\mu\text{s}$ rate | —    | 2.4 | —    | $\mu\text{s}$ |
| EM4 BOD threshold   | $V_{EM4BOD}$         | AVDD rising                              | —    | —   | 1.7  | V             |
|                     |                      | AVDD falling                             | 1.45 | —   | —    | V             |
| EM4 BOD hysteresis  | $V_{EM4BOD\_HYST}$   |  | —    | 46  | —    | mV            |
| EM4 response time   | $t_{EM4BOD\_DELAY}$  | Supply drops at 0.1V/ $\mu\text{s}$ rate | —    | 300 | —    | $\mu\text{s}$ |

#### 4.1.8 Frequency Synthesizer Characteristics

**Table 4.11. Frequency Synthesizer Characteristics**

| Parameter  | Symbol                        | Test Condition          | Min  | Typ | Max    | Unit |
|--|-------------------------------|-------------------------|------|-----|--------|------|
| RF Synthesizer Frequency range                       | $F_{\text{RANGE\_2400}}$      | 2.4 GHz frequency range | 2400 | —   | 2483.5 | MHz  |
| LO tuning frequency range                            | $F_{\text{RANGE\_900}}$       | Sub GHz frequency range | 779  | —   | 956    | MHz  |
|  | $F_{\text{RANGE\_433}}$       |                         | 390  | —   | 574    | MHz  |
|  | $F_{\text{RANGE\_315}}$       |                         | 195  | —   | 358    | MHz  |
|  | $F_{\text{RANGE\_169}}$       |                         | 110  | —   | 191    | MHz  |
| LO tuning frequency resolution with 38.4 MHz crystal | $F_{\text{RES\_2400}}$        | 2400 - 2483.5 MHz       | —    | —   | 73     | Hz   |
|  | $F_{\text{RES\_900}}$         | 779 - 956 MHz           | —    | —   | 24     | Hz   |
|  | $F_{\text{RES\_433}}$         | 390 - 574 MHz           | —    | —   | 12.2   | Hz   |
|  | $F_{\text{RES\_315}}$         | 195 - 358 MHz           | —    | —   | 7.3    | Hz   |
|  | $F_{\text{RES\_169}}$         | 110 - 191 MHz           | —    | —   | 4.6    | Hz   |
| Frequency deviation resolution with 38.4 MHz crystal | $\Delta F_{\text{RES\_2400}}$ | 2400 - 2483.5 MHz       | —    | —   | 73     | Hz   |
|  | $\Delta F_{\text{RES\_900}}$  | 779 - 956 MHz           | —    | —   | 24     | Hz   |
|  | $\Delta F_{\text{RES\_433}}$  | 390 - 574 MHz           | —    | —   | 12.2   | Hz   |
|  | $\Delta F_{\text{RES\_315}}$  | 195 - 358 MHz           | —    | —   | 7.3    | Hz   |
|  | $\Delta F_{\text{RES\_169}}$  | 110 - 191 MHz           | —    | —   | 4.6    | Hz   |
| Maximum frequency deviation with 38.4 MHz crystal    | $\Delta F_{\text{MAX\_2400}}$ | 2400 - 2483.5 MHz       | —    | —   | 1677   | kHz  |
|  | $\Delta F_{\text{MAX\_900}}$  | 779 - 956 MHz           | —    | —   | 559    | kHz  |
|  | $\Delta F_{\text{MAX\_433}}$  | 390 - 574 MHz           | —    | —   | 280    | kHz  |
|  | $\Delta F_{\text{MAX\_315}}$  | 195 - 358 MHz           | —    | —   | 167    | kHz  |
|  | $\Delta F_{\text{MAX\_169}}$  | 110 - 191 MHz           | —    | —   | 105    | kHz  |

#### 4.1.9 2.4 GHz RF Transceiver Characteristics

##### 4.1.9.1 RF Transmitter General Characteristics for the 2.4 GHz Band

Unless otherwise indicated, typical conditions are:  $T_{OP} = 25\text{ }^{\circ}\text{C}$ ,  $V_{REGVDD} = AVDD = IOVDD = 3.3\text{ V}$ ,  $DVDD = RFVDD = PAVDD$ . RFVDD and PAVDD path is filtered using ferrites. Crystal frequency=38.4MHz. RF center frequency 2.45 GHz. Test circuit according to [Figure 5.2 EFR32FG1 Typical Application Circuit: Configuration with DC-DC converter \(PAVDD from VDCDC\) on page 92](#) and [Figure 5.4 Typical 2.4 GHz RF impedance-matching network circuits on page 94](#).

**Table 4.12. RF Transmitter General Characteristics for 2.4 GHz Band**

| Parameter   | Symbol                | Test Condition   | Min  | Typ  | Max    | Unit |
|---|-----------------------|--|------|------|--------|------|
| Maximum TX power <sup>1</sup>                                 | POUT <sub>MAX</sub>   | 19.5 dBm-rated part numbers.<br>PAVDD connected directly to external 3.3V supply                 | —    | 19.5 | —      | dBm  |
|   |                       | 16.5 dBm-rated part numbers.<br>PAVDD connected directly to external 3.3V supply                 | —    | 16.5 | —      | dBm  |
| Minimum active TX Power                                       | POUT <sub>MIN</sub>   | CW   | —    | -30  | —      | dBm  |
| Output power step size  | POUT <sub>STEP</sub>  | -5 dBm < Output power < 0 dBm  | —    | 1    | —      | dB   |
|   |                       | 0 dBm < output power < POUT <sub>MAX</sub>   | —    | 0.5  | —      | dB   |
| Output power variation vs supply at POUT <sub>MAX</sub>       | POUT <sub>VAR_V</sub> | 1.85 V < V <sub>REGVDD</sub> < 3.3 V without DC-DC converter, operation at higher than 10.5 dBm. | —    | 4.5  | —      | dB   |
|   |                       | 1.85 V < V <sub>REGVDD</sub> < 3.3 V using DC-DC converter                                       | —    | 2.2  | —      | dB   |
| Output power variation vs temperature at POUT <sub>MAX</sub>  | POUT <sub>VAR_T</sub> | From -40 to +85 °C, PAVDD connected to DCDC output   | —    | 1.5  | —      | dB   |
|   |                       | From -40 to +85 °C, PAVDD connected to external supply   | —    | 1.5  | —      | dB   |
| Output power variation vs RF frequency at POUT <sub>MAX</sub> | POUT <sub>VAR_F</sub> | Over RF tuning frequency range   | —    | 0.4  | —      | dB   |
| RF tuning frequency range                                     | F <sub>RANGE</sub>    |  | 2400 | —    | 2483.5 | MHz  |

**Note:**

1. Supported transmit power levels are determined by the ordering part number (OPN). Transmit power ratings for all devices covered in this datasheet can be found in the Max TX Power column of [2. Ordering Information](#)

#### 4.1.9.2 RF Receiver General Characteristics for the 2.4 GHz Band

Unless otherwise indicated, typical conditions are:  $T_{OP} = 25\text{ }^{\circ}\text{C}$ ,  $V_{REGVDD} = AVDD = IOVDD = 3.3\text{ V}$ ,  $DVDD = RFVDD = PAVDD$ . RFVDD and PAVDD path is filtered using ferrites. Crystal frequency=38.4MHz. RF center frequency 2.440 GHz. Test circuit according to [Figure 5.2 EFR32FG1 Typical Application Circuit: Configuration with DC-DC converter \(PAVDD from VDCDC\)](#) on page 92 and [Figure 5.4 Typical 2.4 GHz RF impedance-matching network circuits](#) on page 94.

**Table 4.13. RF Receiver General Characteristics for 2.4 GHz Band**

| Parameter  | Symbol            | Test Condition                            | Min  | Typ   | Max    | Unit |
|--|-------------------|---|------|-------|--------|------|
| RF tuning frequency range  | $F_{RANGE}$       |   | 2400 | —     | 2483.5 | MHz  |
| Receive mode maximum spurious emission   | $SPUR_{RX}$       | 30 MHz to 1 GHz                           | —    | -57   | —      | dBm  |
|  |                   | 1 GHz to 12 GHz                           | —    | -47   | —      | dBm  |
| Max spurious emissions during active receive mode, per FCC Part 15.109(a)  | $SPUR_{RX\_FCC}$  | 216 MHz to 960 MHz, Conducted Measurement | —    | -55.2 | —      | dBm  |
|  |                   | Above 960 MHz, Conducted Measurement      | —    | -47.2 | —      | dBm  |
| Level above which RFSENSE will trigger <sup>1</sup>  | $RFSENSE_{TRIG}$  | CW at 2.45 GHz                            | —    | -24   | —      | dBm  |
| Level below which RFSENSE will not trigger <sup>1</sup>  | $RFSENSE_{THRES}$ |   | —    | -50   | —      | dBm  |
| 1% PER Sensitivity   | $SENS_{2GFSK}$    | 2 Mbps 2GFSK signal                       | —    | -89.5 | —      | dBm  |
| 0.1% BER Sensitivity   |                   | 250 kbps 2GFSK signal                     | —    | -99   | —      | dBm  |
| <b>Note:</b><br>1. RFSENSE performance is only valid from 0 to 85 °C. RFSENSE does not meet specified performances outside this Temperature range. |                   |   |      |       |        |      |

#### 4.1.9.3 RF Transmitter Characteristics for 1Mbps 2GFSK in the 2.4 GHz Band

Unless otherwise indicated, typical conditions are:  $T_{OP} = 25\text{ }^{\circ}\text{C}$ ,  $V_{REGVDD} = AVDD = IOVDD = 3.3\text{ V}$ ,  $DVDD = RFVDD = PAVDD$ . RFVDD and PAVDD path is filtered using ferrites. Crystal frequency=38.4MHz. RF center frequency 2.44 GHz. Test circuit according to Figure 5.2 EFR32FG1 Typical Application Circuit: Configuration with DC-DC converter (PAVDD from VDCDC) on page 92 and Figure 5.4 Typical 2.4 GHz RF impedance-matching network circuits on page 94.

**Table 4.14. RF Transmitter Characteristics for 1Mbps 2GFSK in the 2.4GHz Band**

| Parameter  | Symbol                   | Test Condition  | Min | Typ  | Max | Unit     |
|--|--------------------------|---|-----|------|-----|----------|
| Transmit 6dB bandwidth   | TXBW                     |   | —   | 740  | —   | kHz      |
| Power spectral density limit   | PSD <sub>LIMIT</sub>     | Per FCC part 15.247 at 10 dBm   | —   | -6.5 | —   | dBm/3kHz |
|  |                          | Per FCC part 15.247 at 20 dBm   | —   | -2.6 | —   | dBm/3kHz |
|  |                          | Per ETSI 300.328 at 10 dBm/1 MHz  | —   | 10   | —   | dBm      |
| Occupied channel bandwidth per ETSI EN300.328  | OCP <sub>ETSI328</sub>   | 99% BW at highest and lowest channels in band   | —   | 1.1  | —   | MHz      |
| Emissions of harmonics out-of-band, per FCC part 15.247  | SPUR <sub>HARM_FCC</sub> | 2nd,3rd, 5, 6, 8, 9,10 harmonics; continuous transmission of modulated carrier              | —   | -47  | —   | dBm      |
| Spurious emissions out-of-band, per FCC part 15.247, excluding harmonics captured in SPUR <sub>HARM,FCC</sub> . Restricted Bands | SPUR <sub>OOB_FCC</sub>  | Above 2.483 GHz or below 2.4 GHz; continuous transmission of modulated carrier <sup>1</sup> | —   | -47  | —   | dBm      |
|  |                          | Above 2.483 GHz or below 2.4 GHz; continuous transmission of modulated carrier              | —   | -26  | —   | dBc      |
| Spurious emissions out-of-band; per ETSI 300.328   | SPUR <sub>ETSI328</sub>  | [2400-BW to 2400] MHz, [2483.5 to 2483.5+BW] MHz  | —   | -16  | —   | dBm      |
|  |                          | [2400-2BW to 2400-BW] MHz, [2483.5+BW to 2483.5+2BW] MHz per ETSI 300.328                   | —   | -26  | —   | dBm      |
| Spurious emissions per ETSI EN300.440  | SPUR <sub>ETSI440</sub>  | 47-74 MHz,87.5-108 MHz, 174-230 MHz, 470-862 MHz  | —   | -60  | —   | dBm      |
|  |                          | 25-1000 MHz   | —   | -42  | —   | dBm      |
|  |                          | 1-12 GHz  | —   | -36  | —   | dBm      |

**Note:**

1. For 2480 Mhz, a maximum duty cycle of 20% is used to achieve this value.



#### 4.1.9.4 RF Receiver Characteristics for 1Mbps 2GFSK in the 2.4 GHz Band

Unless otherwise indicated, typical conditions are:  $T_{OP} = 25^{\circ}C$ ,  $V_{REGVDD} = AVDD = IOVDD = 3.3 V$ ,  $DVDD = RFVDD = PAVDD$ . RFVDD and PAVDD path is filtered using ferrites. Crystal frequency=38.4MHz. RF center frequency 2.440 GHz. Test circuit according to [Figure 5.2 EFR32FG1 Typical Application Circuit: Configuration with DC-DC converter \(PAVDD from VDCDC\)](#) on page 92 and [Figure 5.4 Typical 2.4 GHz RF impedance-matching network circuits](#) on page 94.

**Table 4.15. RF Receiver Characteristics for 1Mbps 2GFSK in the 2.4GHz Band**

| Parameter   | Symbol               | Test Condition   | Min | Typ   | Max | Unit |
|---|----------------------|--|-----|-------|-----|------|
| Max usable receiver input level, 0.1% BER   | SAT                  | Signal is reference signal <sup>1</sup> . Packet length is 20 bytes.                                     | —   | 10    | —   | dBm  |
| Sensitivity, 0.1% BER   | SENS                 | Signal is reference signal <sup>1</sup> . Using DC-DC converter  | —   | -94   | —   | dBm  |
| Signal to co-channel interferer, 0.1% BER   | C/I <sub>CC</sub>    | Desired signal 3 dB above reference sensitivity  | —   | 8.3   | —   | dB   |
| N+1 adjacent channel (1 MHz) selectivity, 0.1% BER, with allowable exceptions. Desired is reference signal at -67 dBm | C/I <sub>1+</sub>    | Interferer is reference signal at +1 MHz offset. Desired frequency 2402 MHz ≤ F <sub>c</sub> ≤ 2480 MHz  | —   | -3    | —   | dB   |
| N-1 adjacent channel (1 MHz) selectivity, 0.1% BER, with allowable exceptions. Desired is reference signal at -67 dBm | C/I <sub>1-</sub>    | Interferer is reference signal at -1 MHz offset. Desired frequency 2402 MHz ≤ F <sub>c</sub> ≤ 2480 MHz  | —   | -0.5  | —   | dB   |
| Alternate (2 MHz) selectivity, 0.1% BER, with allowable exceptions. Desired is reference signal at -67 dBm            | C/I <sub>2</sub>     | Interferer is reference signal at ± 2 MHz offset. Desired frequency 2402 MHz ≤ F <sub>c</sub> ≤ 2480 MHz | —   | -43   | —   | dB   |
| Alternate (3 MHz) selectivity, 0.1% BER, with allowable exceptions. Desired is reference signal at -67 dBm            | C/I <sub>3</sub>     | Interferer is reference signal at ±3 MHz offset. Desired frequency 2404 MHz ≤ F <sub>c</sub> ≤ 2480 MHz  | —   | -46.7 | —   | dB   |
| Selectivity to image frequency, 0.1% BER. Desired is reference signal at -67 dBm                                      | C/I <sub>IM</sub>    | Interferer is reference signal at image frequency with 1 MHz precision                                   | —   | -38.7 | —   | dB   |
| Selectivity to image frequency +1 MHz, 0.1% BER. Desired is reference signal at -67 dBm                               | C/I <sub>IM+1</sub>  | Interferer is reference signal at image frequency +1 MHz with 1 MHz precision                            | —   | -48.2 | —   | dB   |
| Blocking, 0.1% BER, Desired is reference signal at -67 dBm. Interferer is CW in OOB range.                            | BLOCK <sub>OOB</sub> | Interferer frequency 30 MHz ≤ f ≤ 2000 MHz   | —   | -27   | —   | dBm  |
|   |                      | Interferer frequency 2003 MHz ≤ f ≤ 2399 MHz   | —   | -32   | —   | dBm  |
|   |                      | Interferer frequency 2484 MHz ≤ f ≤ 2997 MHz   | —   | -32   | —   | dBm  |
|   |                      | Interferer frequency 3 GHz ≤ f ≤ 12.75 GHz   | —   | -27   | —   | dBm  |
| Upper limit of input power range over which RSSI resolution is maintained   | RSSI <sub>MAX</sub>  |  | 4   | —     | —   | dBm  |

| Parameter   | Symbol              | Test Condition                                  | Min | Typ | Max  | Unit |
|---|---------------------|---|-----|-----|------|------|
| Lower limit of input power range over which RSSI resolution is maintained | RSSI <sub>MIN</sub> |   | —   | —   | -101 | dBm  |
| RSSI resolution   | RSSI <sub>RES</sub> | Over RSSI <sub>MIN</sub> to RSSI <sub>MAX</sub> | —   | —   | 0.5  | dB   |

**Note:**

- Reference signal is defined 2GFSK at -67 dBm, Modulation index = 0.5, BT = 0.5, Bit rate = 1 Mbps, desired data = PRBS9; interferer data = PRBS15; frequency accuracy better than 1 ppm

#### 4.1.9.5 RF Transmitter Characteristics for 802.15.4 O-QPSK DSSS in the 2.4 GHz Band

Unless otherwise indicated, typical conditions are: T=25 °C, VREGVDD = AVDD = IOVDD = 3.3 V, DVDD = RFVDD = PAVDD. RFVDD and PAVDD path is filtered using ferrites. Crystal frequency=38.4 MHz. RF center frequency 2.45 GHz. Test circuit according to [Figure 5.2 EFR32FG1 Typical Application Circuit: Configuration with DC-DC converter \(PAVDD from VDCDC\) on page 92](#) and [Figure 5.4 Typical 2.4 GHz RF impedance-matching network circuits on page 94](#)

**Table 4.16. RF Transmitter Characteristics for 802.15.4 DSSS-OQPSK in the 2.4GHz Band**

| Parameter   | Symbol                      | Test Condition   | Min | Typ   | Max | Unit     |
|---|-----------------------------|--|-----|-------|-----|----------|
| Error vector magnitude (offset EVM), per 802.15.4-2011, not including 2415 MHz channel  | EVM                         | Average across frequency. Signal is DSSS-OQPSK reference packet <sup>1</sup> | —   | 5.5   | —   | % rms    |
| Power spectral density limit  | PSD <sub>LIMIT</sub>        | Relative, at carrier ±3.5 MHz  | —   | -26   | —   | dBc      |
|   |                             | Absolute, at carrier ±3.5 MHz <sup>2</sup>                                   | —   | -36   | —   | dBm      |
|   |                             | Per FCC part 15.247  | —   | -4.2  | —   | dBm/3kHz |
|   |                             | Output power level which meets 10dBm/MHz ETSI 300.328 specification          | —   | 12    | —   | dBm      |
| Occupied channel bandwidth per ETSI EN300.328   | OCP <sub>ETSI328</sub>      | 99% BW at highest and lowest channels in band                                | —   | 2.25  | —   | MHz      |
| Spurious emissions of harmonics in restricted bands, per FCC Part 15.205 / 15.209 . Pout Max for PAVDD= 3.3V, PAVDD connected to VBATT, 2450MHz | SPUR <sub>HRM_FCC_R</sub>   | Continuous transmission of modulated carrier                                 | —   | -45.8 | —   | dBm      |
|   |                             |  | —   | -26   | —   | dBc      |
| Spurious emissions of harmonics in non-restricted bands, per FCC Part 15.247 / 15.35 Pout Max for PAVDD=3.3V, PAVDD connected to VBATT, 2450MHz | SPUR <sub>HRM_FCC_NRR</sub> |  |     |       |     |          |

| Parameter  | Symbol                     | Test Condition  | Min | Typ   | Max | Unit |
|--|----------------------------|---|-----|-------|-----|------|
| Spurious emissions out-of-band in restricted bands (30-88MHz), per FCC Part 15.205 / 15.209 PAVDD= 3.3V, PAVDD connected to VBATT, 2450MHz   | SPUR <sub>OOB_FCC_R</sub>  | Above 2.483 GHz or below 2.4 GHz; continuous transmission of modulated carrier <sup>3</sup> | —   | -52   | —   | dBm  |
| Spurious emissions out-of-band in restricted bands (88-216MHz), per FCC Part 15.205 / 15.209 PAVDD= 3.3V, PAVDD connected to VBATT, 2450MHz  |                            |   | —   | -62   | —   | dBm  |
| Spurious emissions out-of-band in restricted bands (216-960MHz), per FCC Part 15.205 / 15.209 PAVDD= 3.3V, PAVDD connected to VBATT, 2450MHz |                            |   | —   | -57   | —   | dBm  |
| Spurious emissions out-of-band in restricted bands (>960MHz), per FCC Part 15.205 / 15.209 PAVDD= 3.3V, PAVDD connected to VBATT, 2450MHz    |                            |   | —   | -48   | —   | dBm  |
| Spurious emissions out-of-band, per FCC part 15.247, excluding harmonics, Non Restricted Bands   | SPUR <sub>OOB_FCC_NR</sub> | Above 2.483 GHz or below 2.4 GHz; continuous transmission of modulated carrier              | —   | -26   | —   | dBc  |
| Spurious emissions out-of-band; per ETSI 300.328 <sup>4</sup>  | SPUR <sub>ETSI328</sub>    | [2400-BW to 2400], [2483.5 to 2483.5+BW];   | —   | -36.1 | —   | dBm  |
|  |                            | [2400-2BW to 2400-BW], [2483.5+BW to 2483.5+2BW]; per ETSI 300.328                          | —   | -26   | —   | dBm  |
| Spurious emissions per ETSI EN300.440 <sup>4</sup>   | SPUR <sub>ETSI440</sub>    | 47-74 MHz, 87.5-108 MHz, 174-230 MHz, 470-862 MHz   | —   | -60   | —   | dBm  |
|  |                            | 25-1000 MHz, excluding above frequencies  | —   | -42   | —   | dBm  |
|  |                            | 1G-14G  | —   | -36   | —   | dBm  |

**Note:**

- Reference packet is defined as 20 octet PSDU, modulated according to 802.15.4-2011 DSSS-OQPSK in the 2.4GHz band, with pseudo-random packet data content
- For 2415 Mhz, a maximum duty cycle of 50% is used to achieve this value.
- For 2480 Mhz, a maximum duty cycle of 20% is used to achieve this value.
- Specified at maximum power output level of 10 dBm

#### 4.1.9.6 RF Receiver Characteristics for 802.15.4 O-QPSK DSSS in the 2.4 GHz Band

Unless otherwise indicated, typical conditions are: T=25 °C, VREGVDD = AVDD = IOVDD = 3.3 V, DVDD = RFVDD = PAVDD. RFVDD and PAVDD path is filtered using ferrites. Crystal frequency=38.4 MHz. RF center frequency 2.445 GHz. Test circuit according to [Figure 5.2 EFR32FG1 Typical Application Circuit: Configuration with DC-DC converter \(PAVDD from VDCDC\) on page 92](#) and [Figure 5.4 Typical 2.4 GHz RF impedance-matching network circuits on page 94](#)

**Table 4.17. RF Receiver Characteristics for 802.15.4 DSSS-OQPSK in the 2.4 GHz Band**

| Parameter   | Symbol                  | Test Condition  | Min | Typ   | Max | Unit |
|---|-------------------------|---|-----|-------|-----|------|
| Max usable receiver input level, 1% PER   | SAT                     | Signal is reference signal <sup>1</sup> . Packet length is 20 octets.             | —   | 10    | —   | dBm  |
| Sensitivity, 1% PER   | SENS                    | Signal is reference signal. Packet length is 20 octets. Using DC-DC converter.    | —   | -101  | —   | dBm  |
|   |                         | Signal is reference signal. Packet length is 20 octets. Without DC-DC converter.  | —   | -101  | —   | dBm  |
| Co-channel interferer rejection, 1% PER   | CCR                     | Desired signal 10 dB above sensitivity limit                                      | —   | -2.6  | —   | dB   |
| High-side adjacent channel rejection, 1% PER. Desired is reference signal at 3dB above reference sensitivity level <sup>2</sup>                                       | ACR <sub>+1</sub>       | Interferer is reference signal at +1 channel-spacing.                             | —   | 33.75 | —   | dB   |
|   |                         | Interferer is filtered reference signal <sup>3</sup> at +1 channel-spacing.       | —   | 52.2  | —   | dB   |
|   |                         | Interferer is CW at +1 channel-spacing. <sup>4</sup>                              | —   | 58.6  | —   | dB   |
| Low-side adjacent channel rejection, 1% PER. Desired is reference signal at 3dB above reference sensitivity level <sup>2</sup>  | ACR <sub>-1</sub>       | Interferer is reference signal at -1 channel-spacing.                             | —   | 35    | —   | dB   |
|   |                         | Interferer is filtered reference signal <sup>3</sup> at -1 channel-spacing.       | —   | 54.7  | —   | dB   |
|   |                         | Interferer is CW at -1 channel-spacing.   | —   | 60.1  | —   | dB   |
| Alternate channel rejection, 1% PER. Desired is reference signal at 3dB above reference sensitivity level <sup>2</sup>  | ACR <sub>2</sub>        | Interferer is reference signal at ±2 channel-spacing                              | —   | 45.9  | —   | dB   |
|   |                         | Interferer is filtered reference signal <sup>3</sup> at ±2 channel-spacing        | —   | 56.8  | —   | dB   |
|   |                         | Interferer is CW at ±2 channel-spacing  | —   | 65.5  | —   | dB   |
| Image rejection , 1% PER, Desired is reference signal at 3dB above reference sensitivity level <sup>2</sup>   | IR                      | Interferer is CW in image band <sup>4</sup>                                       | —   | 49.3  | —   | dB   |
| Blocking rejection of all other channels. 1% PER, Desired is reference signal at 3dB above reference sensitivity level <sup>2</sup> . Interferer is reference signal. | BLOCK                   | Interferer frequency < Desired frequency - 3 channel-spacing                      | —   | 57.2  | —   | dB   |
|   |                         | Interferer frequency > Desired frequency + 3 channel-spacing                      | —   | 57.9  | —   | dB   |
| Blocking rejection of 802.11g signal centered at +12MHz or -13MHz   | BLOCK <sub>80211G</sub> | Desired is reference signal at 6dB above reference sensitivity level <sup>2</sup> | —   | 51.6  | —   | dB   |

| Parameter   | Symbol              | Test Condition                                  | Min | Typ  | Max | Unit |
|---|---------------------|---|-----|------|-----|------|
| Upper limit of input power range over which RSSI resolution is maintained | RSSI <sub>MAX</sub> |   | 5   | —    | —   | dBm  |
| Lower limit of input power range over which RSSI resolution is maintained | RSSI <sub>MIN</sub> |   | —   | —    | -98 | dBm  |
| RSSI resolution   | RSSI <sub>RES</sub> | over RSSI <sub>MIN</sub> to RSSI <sub>MAX</sub> | —   | 0.25 | —   | dB   |
| RSSI linearity as defined by 802.15.4-2003                                | RSSI <sub>LIN</sub> |   | —   | 0.5  | —   | dB   |

**Note:**

1. Reference signal is defined as O-QPSK DSSS per 802.15.4, Frequency range = 2400-2483.5 MHz, Symbol rate = 62.5 ksymbols/s
2. Reference sensitivity level is -85 dBm
3. Filter is characterized as a symmetric bandpass centered on the adjacent channel having a 3dB bandwidth of 4.6 MHz and stop-band rejection better than 26 dB beyond 3.15 MHz from the adjacent carrier.
4. Due to low-IF frequency, there is some overlap of adjacent channel and image channel bands. Adjacent channel CW blocker tests place the Interferer center frequency at the Desired frequency  $\pm 5$  MHz on the channel raster, whereas the image rejection test places the CW interferer near the image frequency of the Desired signal carrier, regardless of the channel raster.

#### 4.1.10 Sub-GHz RF Transceiver Characteristics

#### 4.1.10.1 Sub-GHz RF Transmitter Characteristics in the 915 MHz Band

Unless otherwise indicated, typical conditions are:  $T_{OP} = 25\text{ }^{\circ}\text{C}$ ,  $V_{REGVDD} = AVDD = IOVDD = 3.3\text{ V}$ ,  $DVDD = RFVDD = PAVDD$ . RFVDD and PAVDD path is filtered using ferrites. Crystal frequency=38.4MHz. RF center frequency 915 MHz. Test circuit according to Figure 5.2 EFR32FG1 Typical Application Circuit: Configuration with DC-DC converter (PAVDD from VDCDC) on page 92 and Figure 5.5 Typical Sub-GHz RF impedance-matching network circuits on page 95.

**Table 4.18. Sub-GHz RF Transmitter characteristics for 915 MHz Band**

| Parameter   | Symbol          | Test Condition  | Min  | Typ   | Max  | Unit |
|---|-----------------|---|------|-------|------|------|
| RF tuning frequency range                           | $F_{RANGE}$     |   | 902  | —     | 930  | MHz  |
| Maximum TX Power <sup>1</sup>                       | $POUT_{MAX}$    | PAVDD connected directly to external 3.3V supply, 20 dBm output power setting | 17.7 | 20.3  | 24.5 | dBm  |
|   |                 | PAVDD connected to DCDC, 14 dBm output power setting                          | 10.4 | 13.8  | 17.6 | dBm  |
| Minimum active TX Power                             | $POUT_{MIN}$    |   | —    | -45.5 | —    | dBm  |
| Output power step size                              | $POUT_{STEP}$   | output power > 0 dBm  | —    | 0.5   | —    | dB   |
| Output power variation vs supply at $POUT_{MAX}$    | $POUT_{VAR\_V}$ | 1.8 V < $V_{REGVDD}$ < 3.3 V without DCDC                                     | —    | 4.8   | —    | dB   |
|   |                 | 1.8 V < $V_{REGVDD}$ < 3.3 V with DCDC  | —    | 1.9   | —    | dB   |
| Output power variation vs temperature, peak to peak | $POUT_{VAR\_T}$ | -40 to +85C with VBATT  | —    | 0.6   | 1.3  | dB   |
|   |                 | -40 to +85C DCDC  | —    | 0.7   | 1.4  | dB   |
| Output power variation vs RF frequency              | $POUT_{VAR\_F}$ | Without DCDC  | —    | 0.2   | 0.6  | dB   |
|   |                 | With DCDC   | —    | 0.3   | 0.6  | dB   |



| Parameter  | Symbol                      | Test Condition                     | Min | Typ   | Max   | Unit |
|--|-----------------------------|------------------------------------|-----|-------|-------|------|
| Spurious emissions of harmonics in restricted bands, per FCC Part 15.205 / 15.209 . PAVDD= 3.3V, PAVDD connected to DCDC, 915MHz           | SPUR <sub>HARM_FCC_20</sub> | Conducted measurement, 20dBm match | —   | -64.6 | -47   | dBm  |
| Spurious emissions of harmonics in non-restricted bands, per FCC Part 15.231 PAVDD=3.3V, PAVDD connected to DCDC, 915MHz                   |                             |                                    | —   | -64.2 | -42   | dBc  |
| Spurious emissions out-of-band in non-restricted bands, per FCC Part 15.231. PAVDD= 3.3V, PAVDD connected to DCDC, 915MHz                  | SPUR <sub>OOB_FCC_20</sub>  |                                    | —   | -76.2 | -66   | dBc  |
| Spurious emissions out-of-band in restricted bands (30-88MHz), per FCC Part 15.205 / 15.209 PAVDD= 3.3V, PAVDD connected to DCDC, 915MHz   |                             |                                    | —   | -68.8 | -52   | dBm  |
| Spurious emissions out-of-band in restricted bands (88-216MHz), per FCC Part 15.205 / 15.209 PAVDD= 3.3V, PAVDD connected to DCDC, 915MHz  |                             |                                    | —   | -67.7 | -62   | dBm  |
| Spurious emissions out-of-band in restricted bands (216-960MHz), per FCC Part 15.205 / 15.209 PAVDD= 3.3V, PAVDD connected to DCDC, 915MHz |                             |                                    | —   | -69.1 | -58   | dBm  |
| Spurious emissions out-of-band in restricted bands (>960MHz), per FCC Part 15.205 / 15.209 PAVDD= 3.3V, PAVDD connected to DCDC, 915MHz    |                             |                                    | —   | -54.6 | -42.4 | dBm  |

| Parameter   | Symbol                      | Test Condition                     | Min | Typ   | Max | Unit |
|---|-----------------------------|------------------------------------|-----|-------|-----|------|
| Spurious emissions of harmonics in restricted bands, per FCC Part 15.205 / 15.209 . PAVDD= 3.3V, PAVDD connected to VBATT, 915MHz           | SPUR <sub>HARM_FCC_14</sub> | Conducted measurement, 14dBm match | —   | -75.2 | -60 | dBm  |
| Spurious emissions of harmonics in non-restricted bands, per FCC Part 15.231 PAVDD=3.3V, PAVDD connected to VBATT, 915MHz                   |                             |                                    | —   | -69   | -49 | dBc  |
| Spurious emissions out-of-band in non-restricted bands, per FCC Part 15.231. PAVDD= 3.3V, PAVDD connected to VBATT, 915MHz                  | SPUR <sub>OOB_FCC_14</sub>  |                                    | —   | -87.5 | -66 | dBc  |
| Spurious emissions out-of-band in restricted bands (30-88MHz), per FCC Part 15.205 / 15.209 PAVDD= 3.3V, PAVDD connected to VBATT, 915MHz   |                             |                                    | —   | -74.2 | -52 | dBm  |
| Spurious emissions out-of-band in restricted bands (88-216MHz), per FCC Part 15.205 / 15.209 PAVDD= 3.3V, PAVDD connected to VBATT, 915MHz  |                             |                                    | —   | -73.1 | -67 | dBm  |
| Spurious emissions out-of-band in restricted bands (216-960MHz), per FCC Part 15.205 / 15.209 PAVDD= 3.3V, PAVDD connected to VBATT, 915MHz |                             |                                    | —   | -74.3 | -58 | dBm  |
| Spurious emissions out-of-band in restricted bands (>960MHz), per FCC Part 15.205 / 15.209 PAVDD= 3.3V, PAVDD connected to VBATT, 915MHz    |                             |                                    | —   | -60.2 | -49 | dBm  |

**Note:**

- Supported transmit power levels are determined by the ordering part number (OPN). Transmit power ratings for all devices covered in this datasheet can be found in the Max TX Power column of Section 2. [Ordering Information](#)

#### 4.1.10.2 Sub-GHz RF Receiver Characteristics in the 915 MHz Band

Unless otherwise indicated, typical conditions are:  $T_{OP} = 25\text{ }^{\circ}\text{C}$ ,  $V_{REGVDD} = AVDD = IOVDD = 3.3\text{ V}$ ,  $DVDD = RFVDD = PAVDD$ . RFVDD and PAVDD path is filtered using ferrites. Crystal frequency=38.4MHz. RF center frequency 915 MHz. Test circuit according to [Figure 5.2 EFR32FG1 Typical Application Circuit: Configuration with DC-DC converter \(PAVDD from VDCDC\) on page 92](#) and [Figure 5.5 Typical Sub-GHz RF impedance-matching network circuits on page 95](#). Unless otherwise indicated, all interferer tests have been performed with an unmodulated (CW) interferer with the desired signal 3 dB above sensitivity limit.

**Table 4.19. Sub-GHz RF Receiver Characteristics for 915 MHz Band**

| Parameter  | Symbol                   | Test Condition   | Min | Typ    | Max    | Unit |
|--|--------------------------|--|-----|--------|--------|------|
| Tuning frequency range   | F <sub>RANGE</sub>       |  | 902 | —      | 930    | MHz  |
| Max usable input level, 0.1% BER   | SAT                      | Desired is reference 500 kbps GFSK signal <sup>5</sup>                                 | —   | —      | 10     | dBm  |
| Sensitivity  | SENS                     | Desired is reference 4.8 kbps OOK signal <sup>1</sup> , 20% PER                        | —   | -104.7 | -100.7 | dBm  |
|  |                          | Desired is reference 600 bps GFSK signal <sup>2</sup> , 0.1% BER                       | —   | -126.4 | —      | dBm  |
|  |                          | Desired is reference 50 kbps GFSK signal <sup>3</sup> , 0.1% BER                       | —   | -107.5 | -104.2 | dBm  |
|  |                          | Desired is reference 100 kbps GFSK signal <sup>4</sup> , 0.1% BER                      | —   | -105.1 | -101.5 | dBm  |
|  |                          | Desired is reference 500 kbps GFSK signal <sup>5</sup> , 0.1% BER                      | —   | -97.7  | -93.2  | dBm  |
|  |                          | Desired is reference 400 kbps GFSK signal <sup>6</sup> , 1% PER                        | —   | -90.9  | -87.5  | dBm  |
| Level above which RFSENSE will trigger <sup>7</sup>                              | RFSENSE <sub>TRIG</sub>  | CW at 915 MHz  | —   | -25.8  | —      | dBm  |
| Level below which RFSENSE will not trigger <sup>7</sup>                          | RFSENSE <sub>THRES</sub> |  | —   | -50    | —      | dBm  |
| Adjacent channel selectivity, Interferer is CW at $\pm 1 \times$ channel-spacing | C/I <sub>1</sub>         | Desired is 4.8 kbps OOK signal <sup>1</sup> at 3dB above sensitivity level, 20% PER    | —   | 43.7   | —      | dB   |
|  |                          | Desired is 600 bps GFSK signal <sup>2</sup> at 3dB above sensitivity level, 0.1% BER   | —   | 65.76  | —      | dB   |
|  |                          | Desired is 50 kbps GFSK signal <sup>3</sup> at 3dB above sensitivity level, 0.1% BER   | —   | 48.24  | —      | dB   |
|  |                          | Desired is 100 kbps GFSK signal <sup>4</sup> at 3dB above sensitivity level, 0.1% BER  | —   | 51.1   | —      | dB   |
|  |                          | Desired is 500 kbps GFSK signal <sup>5</sup> at 3dB above sensitivity level, 0.1% BER  | —   | 47     | —      | dB   |
|  |                          | Desired is 400 kbps 4GFSK signal <sup>6</sup> at 3dB above sensitivity level, 0.1% BER | —   | 35.9   | —      | dB   |

| Parameter  | Symbol           | Test Condition   | Min | Typ   | Max   | Unit |
|--|------------------|--|-----|-------|-------|------|
| Alternate channel selectivity, Interferer is CW at $\pm 2 \times$ channel-spacing              | $C/I_2$          | Desired is 4.8 kbps OOK signal <sup>1</sup> at 3dB above sensitivity level, 20% PER    | —   | 57.2  | —     | dB   |
|  |                  | Desired is 600 bps GFSK signal <sup>2</sup> at 3dB above sensitivity level, 0.1% BER   | —   | 71.76 | —     | dB   |
|  |                  | Desired is 50 kbps GFSK signal <sup>3</sup> at 3dB above sensitivity level, 0.1% BER   | —   | 53.6  | —     | dB   |
|  |                  | Desired is 100 kbps GFSK signal <sup>4</sup> at 3dB above sensitivity level, 0.1% BER  | —   | 56.9  | —     | dB   |
|  |                  | Desired is 500 kbps GFSK signal <sup>5</sup> at 3dB above sensitivity level, 0.1% BER  | —   | 53.6  | —     | dB   |
|  |                  | Desired is 400 kbps 4GFSK signal <sup>6</sup> at 3dB above sensitivity level, 0.1% BER | —   | 44    | —     | dB   |
| Image rejection, Interferer is CW at image frequency   | $C/I_{IMAGE}$    | Desired is 4.8 kbps OOK signal <sup>1</sup> at 3dB above sensitivity level, 20% PER    | —   | 41.2  | —     | dB   |
|  |                  | Desired is 50 kbps GFSK signal <sup>3</sup> at 3dB above sensitivity level, 0.1% BER   | —   | 52.4  | —     | dB   |
|  |                  | Desired is 100 kbps GFSK signal <sup>4</sup> at 3dB above sensitivity level, 0.1% BER  | —   | 50.35 | —     | dB   |
|  |                  | Desired is 500 kbps GFSK signal <sup>5</sup> at 3dB above sensitivity level, 0.1% BER  | —   | 46.2  | —     | dB   |
|  |                  | Desired is 400 kbps 4GFSK signal <sup>6</sup> at 3dB above sensitivity level, 0.1% BER | —   | 35.9  | —     | dB   |
| Blocking selectivity, 0.1% BER. Desired is 100 kbps GFSK signal at 3dB above sensitivity level | $C/I_{BLOCKER}$  | Interferer CW at Desired $\pm 1$ MHz   | —   | 58.7  | —     | dB   |
|  |                  | Interferer CW at Desired $\pm 2$ MHz   | —   | 60.9  | —     | dB   |
|  |                  | Interferer CW at Desired $\pm 10$ MHz  | —   | 76.4  | —     | dB   |
| Intermod selectivity, 0.1% BER. CW interferers at 400 kHz and 800 kHz offsets                  | $C/I_{IM}$       | Desired is 100 kbps GFSK signal <sup>4</sup> at 3dB above sensitivity level            | —   | 46.1  | —     | dBm  |
| Upper limit of input power range over which RSSI resolution is maintained                      | $RSSI_{MAX}$     |  | —   | —     | 5     | dBm  |
| Lower limit of input power range over which RSSI resolution is maintained                      | $RSSI_{MIN}$     |  | -98 | —     | —     | dBm  |
| RSSI resolution  | $RSSI_{RES}$     | Over $RSSI_{MIN}$ to $RSSI_{MAX}$ range  | —   | 0.25  | —     | dBm  |
| Max spurious emissions during active receive mode, per FCC Part 15.109(a)                      | $SPUR_{RX\_FCC}$ | 216-960 MHz  | —   | -77.7 | -49.2 | dBm  |
|  |                  | Above 960 MHz  | —   | -62.7 | -51.7 | dBm  |

| Parameter  | Symbol                  | Test Condition            | Min | Typ   | Max | Unit |
|--|-------------------------|---------------------------|-----|-------|-----|------|
| Max spurious emissions during active receive mode, per ARIB STD-T108 Section 3.3 | SPUR <sub>RX_ARIB</sub> | Below 710 MHz, RBW=100kHz | —   | -77.7 | -60 | dBm  |
|  |                         | 710-900 MHz, RBW=1MHz     | —   | -75.8 | -61 | dBm  |
|  |                         | 900-915 MHz, RBW=100kHz   | —   | -85.4 | -61 | dBm  |
|  |                         | 915-930 MHz, RBW=100kHz   | —   | -85.6 | -55 | dBm  |
|  |                         | 930-1000 MHz, RBW=100kHz  | —   | -85.1 | -60 | dBm  |
|  |                         | Above 1000 MHz, RBW=1MHz  | —   | -57.9 | -47 | dBm  |

**Note:**

1. Definition of reference signal is 4.8 kbps OOK, RX channel BW = 315.6 kHz, channel spacing = 500 kHz
2. Definition of reference signal is 600 bps 2GFSK, BT=0.5,  $\Delta f = 0.3$  kHz, RX channel BW = 1262 Hz, channel spacing = 300 kHz
3. Definition of reference signal is 50 kbps 2GFSK, BT=0.5,  $\Delta f = 25$  kHz, RX channel BW = 120.229 kHz, channel spacing = 200 kHz
4. Definition of reference signal is 100 kbps 2GFSK, BT=0.5,  $\Delta f = 50$  kHz, RX channel BW = 210.4kHz, channel spacing = 200 kHz
5. Definition of reference signal is 500 kbps 2GFSK, BT=0.5,  $\Delta f = 175$  kHz, RX channel BW = 2524.8 kHz, channel spacing = 1 MHz
6. Definition of reference signal is 400 kbps 4GFSK, BT=0.5, inner deviation = 33.3 kHz, RX channel BW = 336.64 kHz, channel spacing = 600 kHz
7. RFSENSE performance is only valid from 0 to 85 °C. RFSENSE does not meet specified performances outside this Temperature range.

### 4.1.10.3 Sub-GHz RF Transmitter Characteristics in the 868 MHz Band

Unless otherwise indicated, typical conditions are:  $T_{OP} = 25\text{ }^{\circ}\text{C}$ ,  $V_{REGVDD} = AVDD = IOVDD = 3.3\text{ V}$ ,  $DVDD = RFVDD = PAVDD$ . RFVDD and PAVDD path is filtered using ferrites. Crystal frequency=38.4MHz. RF center frequency 868 MHz. Test circuit according to [Figure 5.2 EFR32FG1 Typical Application Circuit: Configuration with DC-DC converter \(PAVDD from VDCDC\) on page 92](#) and [Figure 5.5 Typical Sub-GHz RF impedance-matching network circuits on page 95](#).

**Table 4.20. Sub-GHz RF Transmitter characteristics for 868 MHz Band**

| Parameter  | Symbol                    | Test Condition  | Min  | Typ   | Max   | Unit |
|--|---------------------------|---|------|-------|-------|------|
| RF tuning frequency range  | $F_{RANGE}$               |   | 863  | —     | 876   | MHz  |
| Maximum TX Power <sup>1</sup>  | $POUT_{MAX}$              | PAVDD connected directly to external 3.3V supply, 20 dBm output power setting | 16.6 | 19.6  | 23    | dBm  |
|  |                           | PAVDD connected to DCDC, 14 dBm output power setting                          | 10   | 14.7  | 17.5  | dBm  |
| Minimum active TX Power  | $POUT_{MIN}$              |   | —    | -43.5 | —     | dBm  |
| Output power step size   | $POUT_{STEP}$             | output power > 0 dBm  | —    | 0.5   | —     | dB   |
| Output power variation vs supply at $POUT_{MAX}$   | $POUT_{VAR\_V\_NO\ DCDC}$ | $1.8\text{ V} < V_{REGVDD} < 3.3\text{ V}$ without DCDC                       | —    | 5     | —     | dB   |
|  | $POUT_{VAR\_V\_DC\ DC}$   | $1.8\text{ V} < V_{REGVDD} < 3.3\text{ V}$ with DCDC                          | —    | 2     | —     | dB   |
| Output power variation vs temperature, peak to peak  | $POUT_{VAR\_T\_NO\ DCDC}$ | -40 to +85C with VBATT  | —    | 0.6   | 0.9   | dB   |
|  | $POUT_{VAR\_T\_DC\ DC}$   | -40 to +85C DCDC  | —    | 0.5   | 1.2   | dB   |
| Output power variation vs RF frequency   | $POUT_{VAR\_F\_NO\ DCDC}$ | VBATT   | —    | 0.2   | 0.6   | dB   |
|  | $POUT_{VAR\_F\_DC\ DC}$   | DCDC  | —    | 0.2   | 0.8   | dB   |
| Spurious emissions of harmonics, per ETSI EN 300-220, Section 7.8.2.1  | $SPUR_{HARM\_ETSI}$       | Conducted measurement, PAVDD connected to DCDC                                | —    | -44   | -30   | dB   |
| Spurious emissions, 47-74 / 87.5-118 / 174-230 / 470-862 MHz and 470-862 MHz, per ETSI EN 300-220, Section 7.8.2.1 | $SPUR_{OOB\_ETSI}$        |   | —    | -61.7 | -55.7 | dB   |
| Spurious emissions, other frequencies below 1 GHz, per ETSI EN 300-220, Section 7.8.2.1                            |                           |   | —    | -64.2 | -43.5 | dB   |
| Spurious emissions, frequencies above 1 GHz, per ETSI EN 300-220, Section 7.8.2.1                                  |                           |   | —    | -59.9 | -30   | dB   |

**Note:**

- Supported transmit power levels are determined by the ordering part number (OPN). Transmit power ratings for all devices covered in this datasheet can be found in the Max TX Power column of [Section 2. Ordering Information](#)

#### 4.1.10.4 Sub-GHz RF Receiver Characteristics in the 868 MHz Band

Unless otherwise indicated, typical conditions are:  $T_{OP} = 25\text{ }^{\circ}\text{C}$ ,  $V_{REGVDD} = AVDD = IOVDD = 3.3\text{ V}$ ,  $DVDD = RFVDD = PAVDD$ . RFVDD and PAVDD path is filtered using ferrites. Crystal frequency=38.4MHz. RF center frequency 868 MHz. Test circuit according to [Figure 5.2 EFR32FG1 Typical Application Circuit: Configuration with DC-DC converter \(PAVDD from VDCDC\) on page 92](#) and [Figure 5.5 Typical Sub-GHz RF impedance-matching network circuits on page 95](#). Unless otherwise indicated, all interferer tests have been performed with an unmodulated (CW) interferer with the desired signal 3 dB above sensitivity limit.

**Table 4.21. Sub-GHz RF Receiver Characteristics for 868 MHz Band**

| Parameter  | Symbol            | Test Condition  | Min  | Typ    | Max    | Unit |
|--|-------------------|---|------|--------|--------|------|
| Tuning frequency range   | $F_{RANGE}$       |   | 863  | —      | 876    | MHz  |
| Max usable input level, 0.1% BER   | SAT               | Desired is reference 2.4 kbps GFSK signal <sup>1</sup>                                | —    | —      | 10     | dBm  |
|  |                   | Desired is reference 38.4 kbps GFSK signal <sup>2</sup>                               | —    | —      | 10     | dBm  |
| Sensitivity  | SENS              | Desired is reference 2.4 kbps GFSK signal <sup>1</sup> , 0.1% BER                     | —    | -121.4 | -116.5 | dBm  |
|  |                   | Desired is reference 38.4 kbps GFSK signal <sup>2</sup> , 0.1% BER                    | —    | -109.2 | -105.4 | dBm  |
|  |                   | Desired is reference 500 kbps GFSK signal <sup>3</sup> , 0.1% BER                     | —    | -95.1  | —      | dBm  |
| Level above which RFSENSE will trigger <sup>4</sup>  | $RFSENSE_{TRIG}$  | CW at 868 MHz   | —    | -25.8  | —      | dBm  |
| Level below which RFSENSE will not trigger <sup>4</sup>  | $RFSENSE_{THRES}$ |   | —    | -50    | —      | dBm  |
| Adjacent channel selectivity, Interferer is CW at $\pm 1 \times$ channel-spacing                               | $C/I_1$           | Desired is 2.4 kbps GFSK signal <sup>1</sup> at 3dB above sensitivity level, 0.1% BER | 48.5 | 57.7   | —      | dB   |
|  |                   | Desired is 38.4kbps GFSK signal <sup>2</sup> at 3dB above sensitivity level, 0.1% BER | 36.4 | 44.9   | —      | dB   |
| Alternate channel selectivity, Interferer is CW at $\pm 2 \times$ channel-spacing                              | $C/I_2$           | Desired is 2.4kbps GFSK signal <sup>1</sup> at 3dB above sensitivity level, 0.1% BER  | —    | 59.1   | —      | dB   |
|  |                   | Desired is 38.4kbps GFSK signal <sup>2</sup> at 3dB above sensitivity level, 0.1% BER | —    | 47.7   | —      | dB   |
| Image rejection, Interferer is CW at image frequency   | $C/I_{IMAGE}$     | Desired is 2.4kbps GFSK signal <sup>1</sup> at 3dB above sensitivity level, 0.1% BER  | —    | 47.5   | —      | dB   |
|  |                   | Desired is 38.4kbps GFSK signal <sup>2</sup> at 3dB above sensitivity level, 0.1% BER | —    | 47.2   | —      | dB   |
| Blocking selectivity, 0.1% BER. Desired is 2.4 kbps GFSK signal <sup>1</sup> at 3 dB above sensitivity level . | $C/I_{BLOCKER}$   | Interferer CW at Desired $\pm 1$ MHz  | —    | 71.9   | —      | dB   |
|  |                   | Interferer CW at Desired $\pm 2$ MHz  | —    | 77.9   | —      | dB   |
|  |                   | Interferer CW at Desired $\pm 10$ MHz   | —    | 90.9   | —      | dB   |
| Upper limit of input power range over which RSSI resolution is maintained                                      | $RSSI_{MAX}$      |   | —    | —      | 5      | dBm  |

| Parameter   | Symbol              | Test Condition  | Min | Typ   | Max | Unit |
|---|---------------------|---|-----|-------|-----|------|
| Lower limit of input power range over which RSSI resolution is maintained | RSSI <sub>MIN</sub> |   | -98 | —     | —   | dBm  |
| RSSI resolution   | RSSI <sub>RES</sub> | Over RSSI <sub>MIN</sub> to RSSI <sub>MAX</sub> range | —   | 0.25  | —   | dBm  |
| Max spurious emissions during active receive mode                         | SPUR <sub>RX</sub>  | 30 MHz to 1 GHz                                       | —   | -77.1 | -69 | dBm  |
|   |                     | 1 GHz to 12 GHz                                       | —   | -59.9 | -50 | dBm  |

**Note:**

1. Definition of reference signal is 2.4 kbps 2GFSK, BT=0.5,  $\Delta f = 1.2$  kHz, RX channel BW = 5.05 kHz, channel spacing = 12.5 kHz
2. Definition of reference signal is 38.4 kbps 2GFSK, BT=0.5,  $\Delta f = 20$  kHz, RX channel BW = 84.16 kHz, channel spacing = 100 kHz
3. Definition of reference signal is 500 kbps 2GFSK, BT=0.5,  $\Delta f = 125$  kHz, RX channel BW = 841.6 kHz
4. RFSENSE performance is only valid from 0 to 85 °C. RFSENSE does not meet specified performances outside this Temperature range.



#### 4.1.10.5 Sub-GHz RF Transmitter Characteristics in the 490 MHz Band

Unless otherwise indicated, typical conditions are:  $T_{OP} = 25\text{ }^{\circ}\text{C}$ ,  $V_{REGVDD} = AVDD = IOVDD = 3.3\text{ V}$ ,  $DVDD = RFVDD = PAVDD$ . RFVDD and PAVDD path is filtered using ferrites. Crystal frequency=38.4MHz. RF center frequency 433 MHz. Test circuit according to [Figure 5.2 EFR32FG1 Typical Application Circuit: Configuration with DC-DC converter \(PAVDD from VDCDC\) on page 92](#) and [Figure 5.5 Typical Sub-GHz RF impedance-matching network circuits on page 95](#).

**Table 4.22. Sub-GHz RF Transmitter characteristics for 490 MHz Band**

| Parameter   | Symbol            | Test Condition                                   | Min  | Typ   | Max   | Unit |
|---|-------------------|--|------|-------|-------|------|
| RF tuning frequency range   | $F_{RANGE}$       |  | 584  | —     | 717   | MHz  |
| Maximum TX Power <sup>1</sup>   | $POUT_{MAX}$      | PAVDD connected directly to external 3.3V supply | 18.5 | 21.1  | 23    | dBm  |
| Minimum active TX Power   | $POUT_{MIN}$      |  |      | -44.9 | —     | dBm  |
| Output power step size  | $POUT_{STEP}$     | output power > 0 dBm                             | —    | 0.5   | —     | dB   |
| Output power variation vs supply, peak to peak  | $POUT_{VAR\_V}$   | at 10 dBm; $1.8\text{ V} < VDD < 3.3\text{ V}$   | —    | 4.3   | —     | dB   |
| Output power variation vs temperature, peak to peak   | $POUT_{VAR\_T}$   | -40 to +85C at 20 dBm                            | —    | 0.2   | 0.9   | dB   |
| Output power variation vs RF frequency  | $POUT_{VAR\_F}$   |  | —    | 0.2   | 0.4   | dB   |
| Harmonic emissions, frequencies below 1GHz, per China SRW Requirement, Section 2.1                                    | $SPUR_{HARM\_CN}$ | 20 dBm output power setting, 490MHz              | —    | -41.3 | -34.9 | dBm  |
| Harmonic emissions, frequencies above 1GHz, per China SRW Requirement, Section 2.1                                    |                   |  | —    | -47.2 | -36   | dBm  |
| Spurious emissions, 48.5-72.5MHz, 76-108MHz, 167-223MHz, 470-556MHz, 606-798MHz, per China SRW Requirement, Section 3 | $SPUR_{OOB\_CN}$  |  | —    | -57.5 | —     | dBm  |
| Spurious emissions, other frequencies below 1GHz, per China SRW Requirement, Section 2.1                              |                   |  | —    | -58.5 | —     | dBm  |
| Spurious emissions, frequencies above 1GHz, per China SRW Requirement, Section 2.1                                    |                   |  | —    | -47.9 | —     | dBm  |

**Note:**

- Supported transmit power levels are determined by the ordering part number (OPN). Transmit power ratings for all devices covered in this datasheet can be found in the Max TX Power column of [Section 2. Ordering Information](#)

#### 4.1.10.6 Sub-GHz RF Receiver Characteristics in the 490 MHz Band

Unless otherwise indicated, typical conditions are:  $T_{OP} = 25\text{ }^{\circ}\text{C}$ ,  $V_{REGVDD} = AVDD = IOVDD = 3.3\text{ V}$ ,  $DVDD = RFVDD = PAVDD$ . RFVDD and PAVDD path is filtered using ferrites. Crystal frequency=38.4MHz. RF center frequency 490 MHz. Test circuit according to [Figure 5.2 EFR32FG1 Typical Application Circuit: Configuration with DC-DC converter \(PAVDD from VDCDC\) on page 92](#) and [Figure 5.5 Typical Sub-GHz RF impedance-matching network circuits on page 95](#). Unless otherwise indicated, all interferer tests have been performed with an unmodulated (CW) interferer with the desired signal 3 dB above sensitivity limit.

**Table 4.23. Sub-GHz RF Receiver Characteristics for 490 MHz Band**

| Parameter  | Symbol                   | Test Condition  | Min | Typ    | Max    | Unit |
|--|--------------------------|---|-----|--------|--------|------|
| Tuning frequency range   | F <sub>RANGE</sub>       |   | 584 | —      | 717    | dBm  |
| Max usable input level, 0.1% BER   | SAT                      | Desired is reference 2.4 kbps GFSK signal <sup>1</sup>                                | —   | —      | 10     | dBm  |
|  |                          | Desired is reference 38.4 kbps GFSK signal <sup>2</sup>                               | —   | —      | 10     | dBm  |
| Sensitivity  | SENS                     | Desired is reference 2.4 kbps GFSK signal <sup>1</sup> , 0.1% BER                     | —   | -122.2 | —      | dBm  |
|  |                          | Desired is reference 38.4 kbps GFSK signal <sup>2</sup> , 0.1% BER                    | —   | -111.7 | -108.9 | dBm  |
|  |                          | Desired is reference 10 kbps GFSK signal <sup>3</sup> , 0.1% BER                      | —   | -117.5 | -114.8 | dBm  |
|  |                          | Desired is reference 100 kbps GFSK signal <sup>4</sup> , 0.1% BER                     | —   | -107.6 | -104.7 | dBm  |
| Level above which RFSENSE will trigger <sup>5</sup>  | RFSENSE <sub>TRIG</sub>  | CW at 490 MHz   | —   | -25.8  | —      | dBm  |
| Level below which RFSENSE will not trigger <sup>5</sup>  | RFSENSE <sub>THRES</sub> |   | —   | -50    | —      | dBm  |
| Adjacent channel selectivity, Interferer is CW at $\pm 1 \times$ channel-spacing                               | C/I <sub>1</sub>         | Desired is 2.4 kbps GFSK signal <sup>1</sup> at 3dB above sensitivity level, 0.1% BER | 48  | 58.4   | —      | dB   |
|  |                          | Desired is 38.4kbps GFSK signal <sup>2</sup> at 3dB above sensitivity level, 0.1% BER | 40  | 47.5   | —      | dB   |
| Alternate channel selectivity, Interferer is CW at $\pm 2 \times$ channel-spacing                              | C/I <sub>2</sub>         | Desired is 2.4kbps GFSK signal <sup>1</sup> at 3dB above sensitivity level, 0.1% BER  | —   | 60.8   | —      | dB   |
|  |                          | Desired is 38.4kbps GFSK signal <sup>2</sup> at 3dB above sensitivity level, 0.1% BER | —   | 51.7   | —      | dB   |
| Image rejection, Interferer is CW at image frequency   | C/I <sub>IMAGE</sub>     | Desired is 2.4kbps GFSK signal <sup>1</sup> at 3dB above sensitivity level, 0.1% BER  | —   | 60.9   | —      | dB   |
|  |                          | Desired is 38.4kbps GFSK signal <sup>2</sup> at 3dB above sensitivity level, 0.1% BER | —   | 53     | —      | dB   |
| Blocking selectivity, 0.1% BER. Desired is 2.4 kbps GFSK signal <sup>1</sup> at 3 dB above sensitivity level . | C/I <sub>BLOCKER</sub>   | Interferer CW at Desired $\pm 1$ MHz  | —   | 71.9   | —      | dB   |
|  |                          | Interferer CW at Desired $\pm 2$ MHz  | —   | 74.1   | —      | dB   |
|  |                          | Interferer CW at Desired $\pm 10$ MHz   | —   | 87.9   | —      | dB   |

| Parameter   | Symbol              | Test Condition  | Min | Typ   | Max | Unit |
|---|---------------------|---|-----|-------|-----|------|
| Upper limit of input power range over which RSSI resolution is maintained | RSSI <sub>MAX</sub> |   | —   | —     | 5   | dBm  |
| Lower limit of input power range over which RSSI resolution is maintained | RSSI <sub>MIN</sub> |   | -98 | —     | —   | dBm  |
| RSSI resolution   | RSSI <sub>RES</sub> | Over RSSI <sub>MIN</sub> to RSSI <sub>MAX</sub> range | —   | 0.25  | —   | dBm  |
| Max spurious emissions during active receive mode                         | SPUR <sub>RX</sub>  | 30 MHz to 1 GHz                                       | —   | -84.7 | -54 | dBm  |
|   |                     | 1 GHz to 12 GHz                                       | —   | -66.8 | -54 | dBm  |

**Note:**

1. Definition of reference signal is 2.4 kbps 2GFSK, BT=0.5,  $\Delta f = 1.2$  kHz, RX channel BW = 5.05 kHz, channel spacing = 12.5 kHz
2. Definition of reference signal is 38.4 kbps 2GFSK, BT=0.5,  $\Delta f = 20$  kHz, RX channel BW = 84.16 kHz, channel spacing = 100 kHz
3. Definition of reference signal is 10 kbps 2GFSK, BT=0.5,  $\Delta f = 5$  kHz, RX channel BW = 21.04 kHz
4. Definition of reference signal is 100 kbps 2GFSK, BT=0.5,  $\Delta f = 50$  kHz, RX channel BW = 210.4 kHz
5. RFSense performance is only valid from 0 to 85 °C. RFSense does not meet specified performances outside this Temperature range.

#### 4.1.10.7 Sub-GHz RF Transmitter Characteristics in the 433 MHz Band

Unless otherwise indicated, typical conditions are:  $T_{OP} = 25\text{ }^{\circ}\text{C}$ ,  $V_{REGVDD} = AVDD = IOVDD = 3.3\text{ V}$ ,  $DVDD = RFVDD = PAVDD$ . RFVDD and PAVDD path is filtered using ferrites. Crystal frequency=38.4MHz. RF center frequency 433 MHz. Test circuit according to Figure 5.2 EFR32FG1 Typical Application Circuit: Configuration with DC-DC converter (PAVDD from VDCDC) on page 92 and Figure 5.5 Typical Sub-GHz RF impedance-matching network circuits on page 95.

**Table 4.24. Sub-GHz RF Transmitter characteristics for 433 MHz Band**

| Parameter   | Symbol          | Test Condition                 | Min | Typ  | Max | Unit |
|---|-----------------|--------------------------------|-----|------|-----|------|
| RF tuning frequency range                                       | $F_{RANGE}$     |                                | 426 | —    | 445 | MHz  |
| Maximum TX Power <sup>1</sup>                                   | $POUT_{MAX}$    | PAVDD connected to DCDC        | 11  | 14.3 | 18  | dBm  |
|   |                 |                                | 7   | 10.7 | 14  | dBm  |
| Minimum active TX Power   | $POT_{MIN}$     |                                | —   | -42  | —   | dBm  |
| Output power step size  | $POUT_{STEP}$   | output power > 0 dBm           | —   | 0.5  | —   | dB   |
| Output power variation vs supply, peak to peak Pout = 10dBm     | $POUT_{VAR\_V}$ | at 10 dBm; 1.8 V < VDD < 3.3 V | —   | 1.7  | —   | dB   |
| Output power variation vs temperature, peak to peak Pout= 10dBm | $POUT_{VAR\_T}$ | -40 to +85C at 10dBm           | —   | 0.5  | 1.2 | dB   |
| Output power variation vs RF frequency Pout = 10dBm             | $POUT_{VAR\_F}$ |                                | —   | 0.2  | 0.6 | dB   |

| Parameter  | Symbol                   | Test Condition   | Min | Typ   | Max   | Unit |
|--|--------------------------|--|-----|-------|-------|------|
| Spurious emissions of harmonics in restricted bands per FCC Part 15.205 / 15.209 . PAVDD= 3.3V, PAVDD connected to DCDC, 434MHz            | SPUR <sub>HARM_FCC</sub> | Conducted measurement using rms detector, Pout=+14dBm              | —   | -61.2 | -47   | dBm  |
| Spurious emissions of harmonics in non-restricted bands, per FCC Part 15.231 PAVDD=3.3V, PAVDD connected to DCDC, 434MHz                   |                          | Conducted measurement using peak detector, Pout=+14dBm             | —   | -68.5 | -26   | dBc  |
| Spurious emissions out-of-band in non-restricted bands, per FCC Part 15.231. PAVDD= 3.3V, PAVDD connected to DCDC, 434MHz                  | SPUR <sub>OOB_FCC</sub>  |  | —   | -86.2 | -26   | dBc  |
| Spurious emissions out-of-band in restricted bands (30-88MHz), per FCC Part 15.205 / 15.209 PAVDD= 3.3V, PAVDD connected to DCDC, 434MHz   |                          | Conducted measurement using peak , 434MHz                          | —   | -71.9 | -52   | dBm  |
| Spurious emissions out-of-band in restricted bands (88-216MHz), per FCC Part 15.205 / 15.209 PAVDD= 3.3V, PAVDD connected to DCDC, 434MHz  |                          | Conducted measurement using peak detector, Pout=+14dBm             | —   | -70.2 | -62   | dBm  |
| Spurious emissions out-of-band in restricted bands (216-960MHz), per FCC Part 15.205 / 15.209 PAVDD= 3.3V, PAVDD connected to DCDC, 434MHz |                          |  | —   | -60.5 | -54.5 | dBm  |
| Spurious emissions out-of-band in restricted bands (>960MHz), per FCC Part 15.205 / 15.209 PAVDD= 3.3V, PAVDD connected to DCDC, 434MHz    |                          | Conducted measurement using rms detector, Pout=+14dBm              | —   | -57.7 | -46   | dBm  |
|  |                          |  |     |       |       |      |
| Spurious emissions of harmonics, frequencies below 1Ghz, per ETSI EN 300-220, Section 7.8.2.1, 434MHz                                      | SPUR <sub>HRM_ETSI</sub> | Conducted measurement using peak detector, PAVDD connected to DCDC | —   | -57.3 | -36   | dBm  |
| Spurious emissions of harmonics, frequencies above 1GHz, per ETSI EN 300-220, Section 7.8.2.1, 434MHz                                      |                          |  | —   | -84.5 | -36   | dBm  |

| Parameter  | Symbol                   | Test Condition   | Min | Typ   | Max | Unit |
|--|--------------------------|--|-----|-------|-----|------|
| Spurious emissions, 47-74 / 87.5-118 / 174-230 / 470-862 MHz and 470-862 MHz, per ETSI EN 300-220, Section 7.8.2.1, 434MHz | SPUR <sub>OOB_ETSI</sub> | Conducted measurement using rms detector, PAVDD connected to DCDC  | —   | -65.1 | -60 | dBm  |
| Spurious emissions, other frequencies below 1 GHz, per ETSI EN 300-220, Section 7.8.2.1, 434MHz                            |                          |  | —   | -63.9 | -42 | dBm  |
| Spurious emissions, frequencies above 1 GHz, per ETSI EN 300-220, Section 7.8.2.1, 434MHz                                  |                          | Conducted measurement using peak detector, PAVDD connected to DCDC | —   | -56.8 | -36 | dBm  |

**Note:**

- Supported transmit power levels are determined by the ordering part number (OPN). Transmit power ratings for all devices covered in this datasheet can be found in the Max TX Power column of Section [2. Ordering Information](#)

#### 4.1.10.8 Sub-GHz RF Receiver Characteristics in the 433 MHz Band

Unless otherwise indicated, typical conditions are:  $T_{OP} = 25\text{ }^{\circ}\text{C}$ ,  $V_{REGVDD} = AVDD = IOVDD = 3.3\text{ V}$ ,  $DVDD = RFVDD = PAVDD$ . RFVDD and PAVDD path is filtered using ferrites. Crystal frequency=38.4MHz. RF center frequency 433 MHz. Test circuit according to [Figure 5.2 EFR32FG1 Typical Application Circuit: Configuration with DC-DC converter \(PAVDD from VDCDC\) on page 92](#) and [Figure 5.5 Typical Sub-GHz RF impedance-matching network circuits on page 95](#). Unless otherwise indicated, all interferer tests have been performed with an unmodulated (CW) interferer with the desired signal 3 dB above sensitivity limit.

**Table 4.25. Sub-GHz RF Receiver Characteristics for 433 MHz Band**

| Parameter  | Symbol                   | Test Condition  | Min  | Typ    | Max    | Unit |
|--|--------------------------|---|------|--------|--------|------|
| Tuning frequency range   | F <sub>RANGE</sub>       |   | 426  | —      | 445    | MHz  |
| Max usable input level, 0.1% BER   | SAT                      | Desired is reference 2.4 kbps GFSK signal <sup>4</sup>                                | —    | —      | 10     | dBm  |
|  |                          | Desired is reference 50 kbps GFSK signal <sup>3</sup>                                 | —    | —      | 10     | dBm  |
| Sensitivity  | SENS                     | Desired is reference 4.8 kbps OOK signal <sup>1</sup> , 20% PER                       | —    | -107   | —      | dBm  |
|  |                          | Desired is reference 100 kbps GFSK signal <sup>2</sup> , 0.1% BER                     | —    | -107.5 | -105   | dBm  |
|  |                          | Desired is reference 50 kbps GFSK signal <sup>3</sup> , 0.1% BER                      | —    | -122.3 | —      | dBm  |
|  |                          | Desired is reference 2.4 kbps GFSK signal <sup>4</sup> , 0.1% BER                     | —    | -110   | -107.2 | dBm  |
|  |                          | Desired is reference 9.6 kbps GFSK signal <sup>5</sup> , 1% PER                       | —    | TBD    | —      | dBm  |
| Level above which RFSENSE will trigger <sup>6</sup>                              | RFSENSE <sub>TRIG</sub>  | CW at 433 MHz   | —    | -25.8  | —      | dBm  |
| Level below which RFSENSE will not trigger <sup>6</sup>                          | RFSENSE <sub>THRES</sub> |   | —    | -50    | —      | dBm  |
| Adjacent channel selectivity, Interferer is CW at $\pm 1 \times$ channel-spacing | C/I <sub>1</sub>         | Desired is 4.8 kbps OOK signal <sup>1</sup> at 3dB above sensitivity level, 20% PER   | —    | 46     | —      | dB   |
|  |                          | Desired is 100 kbps GFSK signal <sup>2</sup> at 3dB above sensitivity level, 0.1% BER | 24.8 | 33.4   | —      | dB   |
|  |                          | Desired is 2.4 kbps GFSK signal <sup>4</sup> at 3dB above sensitivity level, 0.1% BER | 47   | 59.1   | —      | dB   |
|  |                          | Desired is 50 kbps GFSK signal <sup>3</sup> at 3dB above sensitivity level, 0.1% BER  | 45.6 | 50.7   | —      | dB   |
|  |                          | Desired is 9.6 kbps 4GFSK signal <sup>5</sup> at 3dB above sensitivity level, 1% PER  | —    | TBD    | —      | dB   |

| Parameter   | Symbol            | Test Condition  | Min | Typ   | Max | Unit |
|---|-------------------|---|-----|-------|-----|------|
| Alternate channel selectivity, Interferer is CW at $\pm 2 \times$ channel-spacing                           | $C/I_2$           | Desired is 4.8 kbps OOK signal <sup>1</sup> at 3dB above sensitivity level, 20% PER   | —   | 56.8  | —   | dB   |
|   |                   | Desired is 100 kbps GFSK signal <sup>2</sup> at 3dB above sensitivity level, 0.1% BER | —   | 56.2  | —   | dB   |
|   |                   | Desired is 2.4 kbps GFSK signal <sup>4</sup> at 3dB above sensitivity level, 0.1% BER | —   | 62.2  | —   | dB   |
|   |                   | Desired is 50 kbps GFSK signal <sup>3</sup> at 3dB above sensitivity level, 0.1% BER  | —   | 57.4  | —   | dB   |
|   |                   | Desired is 9.6 kbps 4GFSK signal <sup>5</sup> at 3dB above sensitivity level, 1% PER  | —   | TBD   | —   | dB   |
| Image rejection, Interferer is CW at image frequency  | $C/I_{IMAGE}$     | Desired is 4.8 kbps OOK signal <sup>1</sup> at 3dB above sensitivity level, 20% PER   | —   | 42.2  | —   | dB   |
|   |                   | Desired is 100 kbps GFSK signal <sup>2</sup> at 3dB above sensitivity level, 0.1% BER | —   | 50    | —   | dB   |
|   |                   | Desired is 2.4 kbps GFSK signal <sup>4</sup> at 3dB above sensitivity level, 0.1% BER | —   | 52.3  | —   | dB   |
|   |                   | Desired is 50 kbps GFSK signal <sup>3</sup> at 3dB above sensitivity level, 0.1% BER  | —   | 53    | —   | dB   |
|   |                   | Desired is 9.6 kbps 4GFSK signal <sup>5</sup> at 3dB above sensitivity level, 1% PER  | —   | TBD   | —   | dB   |
| Blocking selectivity, 0.1% BER. Desired is 2.4 kbps GFSK signal <sup>4</sup> at 3dB above sensitivity level | $C/I_{BLOCKER}$   | Interferer CW at Desired $\pm 1$ MHz  | —   | 73.8  | —   | dB   |
|   |                   | Interferer CW at Desired $\pm 2$ MHz  | —   | 75.7  | —   | dB   |
|   |                   | Interferer CW at Desired $\pm 10$ MHz   | —   | 89.9  | —   | dB   |
| Intermod selectivity, 0.1% BER. CW interferers at TBD kHz and TBD kHz offsets                               | $C/I_{IM}$        | Desired is 2.4 kbps GFSK signal <sup>4</sup> at 3dB above sensitivity level           | —   | 59.1  | —   | dBm  |
| Upper limit of input power range over which RSSI resolution is maintained                                   | $RSSI_{MAX}$      |   | —   | —     | 5   | dBm  |
| Lower limit of input power range over which RSSI resolution is maintained                                   | $RSSI_{MIN}$      |   | -98 | —     | —   | dBm  |
| RSSI resolution   | $RSSI_{RES}$      | Over $RSSI_{MIN}$ to $RSSI_{MAX}$ range   | —   | 0.25  | —   | dBm  |
| Max spurious emissions during active receive mode, per FCC Part 15.109(a)                                   | $SPUR_{RX\_FCC}$  | 216-960 MHz   | —   | -83.5 | -57 | dBm  |
|   |                   | Above 960 MHz   | —   | -62.5 | -52 | dBm  |
| Max spurious emissions during active receive mode, per ETSI 300-220 Section 8.6                             | $SPUR_{RX\_ETSI}$ | below 1000 MHz  | —   | -84.6 | -57 | dBm  |
|   |                   | Above 1000 MHz  | —   | -59.7 | -52 | dBm  |



| Parameter  | Symbol            | Test Condition            | Min | Typ   | Max | Unit |
|--|-------------------|---------------------------|-----|-------|-----|------|
| Max spurious emissions during active receive mode, per ARIB STD T67 Section 3.3(5) | $SPUR_{RX\_ARIB}$ | Below 710 MHz, RBW=100kHz | —   | -83.6 | -57 | dBm  |

**Note:**

1. Definition of reference signal is 4.8 kbps OOK, RX channel BW = 315.6 kHz, channel spacing = 500 kHz
2. Definition of reference signal is 100 kbps 2GFSK, BT=0.5,  $\Delta f = 50$  kHz, RX channel BW = 210.4 kHz, channel spacing = 200 kHz
3. Definition of reference signal is 50 kbps 2GFSK, BT=0.5,  $\Delta f = 25$  kHz, RX channel BW = 120.229 kHz, channel spacing = 200 kHz
4. Definition of reference signal is 2.4 kbps 2GFSK, BT=0.5,  $\Delta f = 1.2$  kHz, RX channel BW = 5.05 kHz, channel spacing = 12.5 kHz
5. Definition of reference signal is 9.6 kbps 4GFSK, BT=0.5, inner deviation = 0.8 kHz, RX channel BW = TBD, channel spacing = TBD
6. RFSENSE performance is only valid from 0 to 85 °C. RFSENSE does not meet specified performances outside this Temperature range.

#### 4.1.10.9 Sub-GHz RF Transmitter Characteristics in the 315 MHz Band

Unless otherwise indicated, typical conditions are:  $T_{OP} = 25\text{ }^{\circ}\text{C}$ ,  $V_{REGVDD} = AVDD = IOVDD = 3.3\text{ V}$ ,  $DVDD = RFVDD = PAVDD$ . RFVDD and PAVDD path is filtered using ferrites. Crystal frequency=38.4MHz. RF center frequency 315 MHz. Test circuit according to Figure 5.2 EFR32FG1 Typical Application Circuit: Configuration with DC-DC converter (PAVDD from VDCDC) on page 92 and Figure 5.5 Typical Sub-GHz RF impedance-matching network circuits on page 95.

**Table 4.26. Sub-GHz RF Transmitter characteristics for 315 MHz Band**

| Parameter                              | Symbol          | Test Condition                                   | Min  | Typ   | Max | Unit |
|--|-----------------|--|------|-------|-----|------|
| RF tuning frequency range              | $F_{RANGE}$     |  | 195  | —     | 358 | MHz  |
| Maximum TX Power <sup>1</sup>          | $POUT_{MAX}$    | PAVDD connected directly to external 3.3V supply | 10.8 | 15.3  | 17  | dBm  |
| Minimum active TX Power                | $POUT_{MIN}$    |  |      | -43.9 | —   | dBm  |
| Output power step size                 | $POUT_{STEP}$   | output power > 0 dBm                             | —    | 0.5   | —   | dB   |
| Output power variation vs supply       | $POUT_{VAR\_V}$ | 1.8 V < VDD < 3.3 V                              | —    | 1.8   | —   | dB   |
| Output power variation vs temperature  | $POUT_{VAR\_T}$ |  | —    | 0.5   | 1.2 | dB   |
| Output power variation vs RF frequency | $POUT_{VAR\_F}$ |  | —    | 0.1   | 0.7 | dB   |

| Parameter  | Symbol                   | Test Condition  | Min | Typ   | Max | Unit |
|--|--------------------------|---|-----|-------|-----|------|
| Spurious emissions of harmonics in restricted bands, per FCC Part 15.205 / 15.209 . PAVDD= 3.3V, PAVDD connected to DCDC, 303MHz           | SPUR <sub>HARM_FCC</sub> | Conducted measurement using averaging detector, Pout=+14dBm | —   | -53.8 | -47 | dBm  |
| Spurious emissions of harmonics in non-restricted bands, per FCC Part 15.231 PAVDD=3.3V, PAVDD connected to DCDC, 303MHz                   |                          |   | —   | -63.4 | -26 | dBc  |
| Spurious emissions out-of-band in non-restricted bands, per FCC Part 15.231. PAVDD= 3.3V, PAVDD connected to DCDC, 303MHz                  | SPUR <sub>OOB_FCC</sub>  |   | —   | -76.6 | -26 | dBc  |
| Spurious emissions out-of-band in restricted bands (30-88MHz), per FCC Part 15.205 / 15.209 PAVDD= 3.3V, PAVDD connected to DCDC, 303MHz   |                          |   | —   | -71.8 | -51 | dBm  |
| Spurious emissions out-of-band in restricted bands (88-216MHz), per FCC Part 15.205 / 15.209 PAVDD= 3.3V, PAVDD connected to DCDC, 303MHz  |                          |   | —   | -70.2 | -61 | dBm  |
| Spurious emissions out-of-band in restricted bands (216-960MHz), per FCC Part 15.205 / 15.209 PAVDD= 3.3V, PAVDD connected to DCDC, 303MHz |                          |   | —   | -68.2 | -57 | dBm  |
| Spurious emissions out-of-band in restricted bands (>960MHz), per FCC Part 15.205 / 15.209 PAVDD= 3.3V, PAVDD connected to DCDC, 303MHz    |                          |   | —   | -57.5 | -46 | dBm  |

**Note:**

- Supported transmit power levels are determined by the ordering part number (OPN). Transmit power ratings for all devices covered in this datasheet can be found in the Max TX Power column of Section 2. [Ordering Information](#)

#### 4.1.10.10 Sub-GHz RF Receiver Characteristics in the 315 MHz Band

Unless otherwise indicated, typical conditions are:  $T_{OP} = 25\text{ }^{\circ}\text{C}$ ,  $V_{REGVDD} = AVDD = IOVDD = 3.3\text{ V}$ ,  $DVDD = RFVDD = PAVDD$ . RFVDD and PAVDD path is filtered using ferrites. Crystal frequency=38.4MHz. RF center frequency 315 MHz. Test circuit according to [Figure 5.2 EFR32FG1 Typical Application Circuit: Configuration with DC-DC converter \(PAVDD from VDCCDC\) on page 92](#) and [Figure 5.5 Typical Sub-GHz RF impedance-matching network circuits on page 95](#). Unless otherwise indicated, all interferer tests have been performed with an unmodulated (CW) interferer with the desired signal 3 dB above sensitivity limit.

**Table 4.27. Sub-GHz RF Receiver Characteristics for 315 MHz Band**

| Parameter  | Symbol                   | Test Condition  | Min  | Typ    | Max    | Unit |
|--|--------------------------|---|------|--------|--------|------|
| Tuning frequency range   | F <sub>RANGE</sub>       |   | 195  | —      | 358    | dBm  |
| Max usable input level, 0.1% BER   | SAT                      | Desired is reference 2.4 kbps GFSK signal <sup>1</sup>  | —    | —      | 10     | dBm  |
|  |                          | Desired is reference 38.4 kbps GFSK signal <sup>2</sup>   | —    | —      | 10     | dBm  |
| Sensitivity  | SENS                     | Desired is reference 2.4 kbps GFSK signal <sup>1</sup> , 0.1% BER                                   | —    | -123.5 | -120.7 | dBm  |
|  |                          | Desired is reference 38.4 kbps GFSK signal <sup>2</sup> , 0.1% BER                                  | —    | -111.4 | -108.6 | dBm  |
|  |                          | Desired is reference 500 kbps GFSK signal <sup>3</sup> , 0.1% BER                                   | —    | -97.2  | -94.6  | dBm  |
| Level above which RFSENSE will trigger <sup>4</sup>  | RFSENSE <sub>TRIG</sub>  | CW at 315 MHz   | —    | -25.8  | —      | dBm  |
| Level below which RFSENSE will not trigger <sup>4</sup>  | RFSENSE <sub>THRES</sub> |   | —    | -50    | —      | dBm  |
| Adjacent channel selectivity, Interferer is CW at $\pm 1 \times$ channel-spacing                               | C/I <sub>1</sub>         | Desired is 2.4 kbps GFSK signal <sup>1</sup> at 3dB above sensitivity level, 0.1% BER               | 54.1 | 64.2   | —      | dB   |
|  |                          | Desired is 38.4kbps GFSK signal <sup>2</sup> at 3dB above sensitivity level, 0.1% BER               | 46   | 50     | —      | dB   |
| Alternate channel selectivity, Interferer is CW at $\pm 2 \times$ channel-spacing                              | C/I <sub>2</sub>         | Desired is 2.4kbps GFSK signal <sup>1</sup> at 3dB above sensitivity level, 0.1% BER                | —    | 66     | —      | dB   |
|  |                          | Desired is 38.4kbps GFSK signal <sup>2</sup> at 3dB above sensitivity level <sup>2</sup> , 0.1% BER | —    | 54     | —      | dB   |
| Image rejection, Interferer is CW at image frequency   | C/I <sub>IMAGE</sub>     | Desired is 2.4kbps GFSK signal <sup>1</sup> at 3dB above sensitivity level, 0.1% BER                | —    | 54.4   | —      | dB   |
|  |                          | Desired is 38.4kbps GFSK signal <sup>2</sup> at 3dB above sensitivity level, 0.1% BER               | —    | 51.9   | —      | dB   |
| Blocking selectivity, 0.1% BER. Desired is 2.4 kbps GFSK signal <sup>1</sup> at 3 dB above sensitivity level . | C/I <sub>BLOCKER</sub>   | Interferer CW at Desired $\pm 1$ MHz  | —    | 74.9   | —      | dB   |
|  |                          | Interferer CW at Desired $\pm 2$ MHz  | —    | 76.7   | —      | dB   |
|  |                          | Interferer CW at Desired $\pm 10$ MHz   | 72.6 | 93.1   | —      | dB   |

| Parameter   | Symbol              | Test Condition  | Min | Typ   | Max | Unit |
|---|---------------------|---|-----|-------|-----|------|
| Upper limit of input power range over which RSSI resolution is maintained | RSSI <sub>MAX</sub> |   | —   | —     | 5   | dBm  |
| Lower limit of input power range over which RSSI resolution is maintained | RSSI <sub>MIN</sub> |   | -98 | —     | —   | dBm  |
| RSSI resolution   | RSSI <sub>RES</sub> | Over RSSI <sub>MIN</sub> to RSSI <sub>MAX</sub> range | —   | 0.25  | —   | dBm  |
| Max spurious emissions during active receive mode                         | SPUR <sub>RX</sub>  | FCC 216 to 960 MHz                                    | —   | -87.4 | -55 | dBm  |
|   |                     | FCC >960MHz   | —   | -76.7 | -47 | dBm  |

**Note:**

1. Definition of reference signal is 2.4 kbps 2GFSK, BT=0.5,  $\Delta f = 1.2$  kHz, RX channel BW = 5.05 kHz, channel spacing = 12.5 kHz
2. Definition of reference signal is 38.4 kbps 2GFSK, BT=0.5,  $\Delta f = 20$  kHz, RX channel BW = 84.16 kHz, channel spacing = 100 kHz
3. Definition of reference signal is 500 kbps 2GFSK, BT=0.5,  $\Delta f = 125$  kHz, RX channel BW = 841.6 kHz
4. RFSense performance is only valid from 0 to 85 °C. RFSense does not meet specified performances outside this Temperature range.

#### 4.1.10.11 Sub-GHz RF Transmitter Characteristics in the 169 MHz Band

Unless otherwise indicated, typical conditions are:  $T_{OP} = 25\text{ }^{\circ}\text{C}$ ,  $V_{REGVDD} = AVDD = IOVDD = 3.3\text{ V}$ ,  $DVDD = RFVDD = PAVDD$ . RFVDD and PAVDD path is filtered using ferrites. Crystal frequency=38.4MHz. RF center frequency 169.5MHz. Test circuit according to [Figure 5.2 EFR32FG1 Typical Application Circuit: Configuration with DC-DC converter \(PAVDD from VDCDC\) on page 92](#) and [Figure 5.5 Typical Sub-GHz RF impedance-matching network circuits on page 95](#).

**Table 4.28. Sub-GHz RF Transmitter characteristics for 169 MHz Band**

| Parameter  | Symbol              | Test Condition                                   | Min                | Typ   | Max   | Unit |
|--|---------------------|--|--------------------|-------|-------|------|
| RF tuning frequency range  | $F_{RANGE}$         |  | 169                | —     | 170   | MHz  |
| Maximum TX Power <sup>1</sup>  | $POUT_{MAX}$        | PAVDD connected to DCDC                          | 18.4               | 20.4  | 23.3  | dBm  |
| Minimum active TX Power  | $POUT_{MIN}$        |  |                    | -42.6 | —     | dBm  |
| Output power step size   | $POUT_{STEP}$       | output power > 0 dBm                             | —                  | 0.5   | —     | dB   |
| Output power variation vs supply, peak to peak   | $POUT_{VAR\_VDD}$   | 1.8 V < VDD < 3.3 V                              | —                  | 4.8   | —     | dB   |
| Output power variation vs temperature, peak to peak  | $POUT_{VAR\_TEMP}$  | -40 to +85C at 10dBm                             | —                  | 0.6   | 1.2   | dB   |
| Harmonic emissions above 1 GHz, per ETSI EN 300-220, Section 7.8.2.1   | $SPUR_{HARM\_ETSI}$ | Conducted measurement, $P_{out} = +20\text{dBm}$ | —                  | -49.3 | -36   | dBm  |
| Harmonic emissions, 47-74 MHz, 87.5-118 MHz, 174-230 MHz and 470-862 MHz, per ETSI EN 300-220, Section 7.8.2.1                       |                     |  | —                  | -58.2 | -53   | dBm  |
| Harmonic emissions, other frequencies below 1 GHz, per ETSI EN 300-220, Section 7.8.2.1  |                     |  | —                  | -38.9 | -25.4 | dBm  |
| Spurious emissions (excluding harmonics) above 1 GHz, per ETSI EN 300-220, Section 7.8.2.1   |                     |  | $SPUR_{OOB\_ETSI}$ | —     | -61.8 | -36  |
| Spurious emissions (excluding harmonics), 47-74 MHz, 87.5-118 MHz, 174-230 MHz and 470-862 MHz, per ETSI EN 300-220, Section 7.8.2.1 | —                   | -62  |                    | -54   | dBm   |      |
| Spurious emissions (excluding harmonics), other frequencies below 1 GHz, per ETSI EN 300-220, Section 7.8.2.1                        | —                   | -47.6  |                    | -41.1 | dBm   |      |

**Note:**

1. Supported transmit power levels are determined by the ordering part number (OPN). Transmit power ratings for all devices covered in this datasheet can be found in the Max TX Power column of [Section 2. Ordering Information](#)

#### 4.1.10.12 Sub-GHz RF Receiver Characteristics in the 169 MHz Band

Unless otherwise indicated, typical conditions are:  $T_{OP} = 25^{\circ}C$ ,  $V_{REGVDD} = AVDD = IOVDD = 3.3 V$ ,  $DVDD = RFVDD = PAVDD$ . RFVDD and PAVDD path is filtered using ferrites. Crystal frequency=38.4MHz. RF center frequency 169.5MHz. Test circuit according to [Figure 5.2 EFR32FG1 Typical Application Circuit: Configuration with DC-DC converter \(PAVDD from VDCDC\)](#) on page 92 and [Figure 5.5 Typical Sub-GHz RF impedance-matching network circuits](#) on page 95. Unless otherwise indicated, all interferer tests have been performed with an unmodulated (CW) interferer with the desired signal 3 dB above sensitivity limit.

**Table 4.29. Sub-GHz RF Receiver Characteristics for 169 MHz Band**

| Parameter  | Symbol                   | Test Condition  | Min  | Typ    | Max   | Unit |
|--|--------------------------|---|------|--------|-------|------|
| Tuning frequency range   | F <sub>RANGE</sub>       |   | 169  | —      | 170   | dBm  |
| Max usable input level, 0.1% BER   | SAT                      | Desired is reference 2.4 kbps GFSK signal <sup>1</sup>                                | —    | —      | 10    | dBm  |
|  |                          | Desired is reference 38.4 kbps GFSK signal <sup>2</sup>                               | —    | —      | 10    | dBm  |
| Sensitivity  | SENS                     | Desired is reference 2.4 kbps GFSK signal <sup>1</sup> , 0.1% BER                     | —    | -124   | —     | dBm  |
|  |                          | Desired is reference 38.4 kbps GFSK signal <sup>2</sup> , 0.1% BER                    | —    | -111.9 | -108  | dBm  |
|  |                          | Desired is reference 500 kbps GFSK signal <sup>3</sup> , 0.1% BER                     | —    | -97.7  | -94.6 | dBm  |
| Level above which RFSENSE will trigger <sup>4</sup>  | RFSENSE <sub>TRIG</sub>  | CW at 169 MHz   | —    | -25.8  | —     | dBm  |
| Level below which RFSENSE will not trigger <sup>4</sup>  | RFSENSE <sub>THRES</sub> |   | —    | -50    | —     | dBm  |
| Adjacent channel selectivity, Interferer is CW at $\pm 1 \times$ channel-spacing                               | C/I <sub>1</sub>         | Desired is 2.4 kbps GFSK signal <sup>1</sup> at 3dB above sensitivity level, 0.1% BER | —    | 65     | —     | dB   |
|  |                          | Desired is 38.4kbps GFSK signal <sup>1</sup> at 3dB above sensitivity level, 0.1% BER | 43.3 | 50.4   | —     | dB   |
| Alternate channel selectivity, Interferer is CW at $\pm 2 \times$ channel-spacing                              | C/I <sub>2</sub>         | Desired is 2.4kbps GFSK signal <sup>1</sup> at 3dB above sensitivity level, 0.1% BER  | —    | 67.9   | —     | dB   |
|  |                          | Desired is 38.4kbps GFSK signal <sup>2</sup> at 3dB above sensitivity level, 0.1% BER | —    | 55.5   | —     | dB   |
| Image rejection, Interferer is CW at image frequency   | C/I <sub>IMAGE</sub>     | Desired is 2.4kbps GFSK signal <sup>1</sup> at 3dB above sensitivity level, 0.1% BER  | —    | 54.6   | —     | dB   |
|  |                          | Desired is 38.4kbps GFSK signal <sup>2</sup> at 3dB above sensitivity level, 0.1% BER | —    | 51     | —     | dB   |
| Blocking selectivity, 0.1% BER. Desired is 2.4 kbps GFSK signal <sup>1</sup> at 3 dB above sensitivity level . | C/I <sub>BLOCKER</sub>   | Interferer CW at Desired $\pm 1$ MHz  | —    | 74.2   | —     | dB   |
|  |                          | Interferer CW at Desired $\pm 2$ MHz  | 68.7 | 76     | —     | dB   |
|  |                          | Interferer CW at Desired $\pm 10$ MHz   | 80   | 90.6   | —     | dB   |
| Upper limit of input power range over which RSSI resolution is maintained                                      | RSSI <sub>MAX</sub>      |   | —    | —      | 5     | dBm  |

| Parameter   | Symbol              | Test Condition  | Min | Typ   | Max | Unit |
|---|---------------------|---|-----|-------|-----|------|
| Lower limit of input power range over which RSSI resolution is maintained | RSSI <sub>MIN</sub> |   | -98 | —     | —   | dBm  |
| RSSI resolution   | RSSI <sub>RES</sub> | Over RSSI <sub>MIN</sub> to RSSI <sub>MAX</sub> range | —   | 0.25  | —   | dBm  |
| Max spurious emissions during active receive mode                         | SPUR <sub>RX</sub>  | 30 MHz to 1 GHz                                       | —   | -83.7 | -63 | dBm  |
|   |                     | 1 GHz to 12 GHz                                       | —   | -58.8 | -50 | dBm  |

**Note:**

1. Definition of reference signal is 2.4 kbps 2GFSK, BT=0.5, Δf = 1.2 kHz, RX channel BW = 5.05 kHz, channel spacing = 12.5 kHz
2. Definition of reference signal is 38.4 kbps 2GFSK, BT=0.5, Δf = 20 kHz, RX channel BW = 84.16 kHz, channel spacing = 100 kHz
3. Definition of reference signal is 500 kbps 2GFSK, BT=0.5, Δf = 125 kHz, RX channel BW = 841.6 kHz
4. RFSENSE performance is only valid from 0 to 85 °C. RFSENSE does not meet specified performances outside this Temperature range.

**4.1.11 Modem Features**

**Table 4.30. Modem Features**

| Parameter         | Symbol                  | Test Condition  | Min | Typ | Max  | Unit |
|-------------------|-------------------------|---|-----|-----|------|------|
| Receive Bandwidth | RX <sub>Bandwidth</sub> | Configurable range with 38.4 MHz crystal                            | 0.1 | —   | 2530 | kHz  |
| IF Frequency      | IF <sub>Freq</sub>      | Configurable range with 38.4 MHz crystal. Selected steps available. | 150 | —   | 1371 | kHz  |



## 4.1.12 Oscillators

### 4.1.12.1 LFXO

Table 4.31. LFXO

| Parameter  | Symbol         | Test Condition   | Min | Typ    | Max | Unit       |
|--|----------------|--|-----|--------|-----|------------|
| Crystal frequency  | $f_{LFXO}$     |  | —   | 32.768 | —   | kHz        |
| Supported crystal equivalent series resistance (ESR)     | $ESR_{LFXO}$   |  | —   | —      | 70  | k $\Omega$ |
| Supported range of crystal load capacitance <sup>1</sup> | $C_{LFXO\_CL}$ |  | 6   | —      | 18  | pF         |
| On-chip tuning cap range <sup>2</sup>                    | $C_{LFXO\_T}$  | On each of LFX TAL_N and LFX TAL_P pins  | 8   | —      | 40  | pF         |
| On-chip tuning cap step size                             | $SS_{LFXO}$    |  | —   | 0.25   | —   | pF         |
| Current consumption after startup <sup>3</sup>           | $I_{LFXO}$     | ESR = 70 k $\Omega$ , $C_L$ =7 pF, GAIN <sup>4</sup> = 3, AGC <sup>4</sup> = 1 | —   | 273    | —   | nA         |
| Start- up time   | $t_{LFXO}$     | ESR=70 k $\Omega$ , $C_L$ =7 pF, GAIN <sup>4</sup> =2                          | —   | 308    | —   | ms         |

**Note:**

1. Total load capacitance as seen by the crystal
2. The effective load capacitance seen by the crystal will be  $C_{LFXO\_T} / 2$ . This is because each XTAL pin has a tuning cap and the two caps will be seen in series by the crystal.
3. Block is supplied by AVDD if ANASW = 0, or DVDD if ANASW=1 in EMU\_PWRCTRL register
4. In CMU\_LFXOCTRL register

#### 4.1.12.2 HFXO

**Table 4.32. HFXO**

| Parameter  | Symbol                     | Test Condition                              | Min | Typ  | Max | Unit          |
|--|----------------------------|---|-----|------|-----|---------------|
| Crystal Frequency  | $f_{\text{HFXO}}$          |   | 38  | 38.4 | 40  | MHz           |
| Supported crystal equivalent series resistance (ESR)     | $\text{ESR}_{\text{HFXO}}$ | Crystal frequency 38.4 MHz                  | —   | —    | 60  | $\Omega$      |
| Supported range of crystal load capacitance <sup>1</sup> | $C_{\text{HFXO\_CL}}$      |   | 6   | —    | 12  | pF            |
| On-chip tuning cap range <sup>2</sup>                    | $C_{\text{HFXO\_T}}$       | On each of HFXTAL_N and HFXTAL_P pins       | 9   | 20   | 25  | pF            |
| On-chip tuning capacitance step                          | $\text{SS}_{\text{HFXO}}$  |   | —   | 0.04 | —   | pF            |
| Startup time   | $t_{\text{HFXO}}$          | 38.4 MHz: ESR=50 $\Omega$ , $C_L = 10$ pF   | —   | 300  | —   | $\mu\text{s}$ |
| Frequency Tolerance for the crystal                      | $\text{FT}_{\text{HFXO}}$  | 38.4 MHz, ESR = 50 $\Omega$ , $C_L = 10$ pF | -40 | —    | 40  | ppm           |

**Note:**

1. Total load capacitance as seen by the crystal
2. The effective load capacitance seen by the crystal will be  $C_{\text{HFXO\_T}}/2$ . This is because each XTAL pin has a tuning cap and the two caps will be seen in series by the crystal.

#### 4.1.12.3 LFRCO

**Table 4.33. LFRCO**

| Parameter                        | Symbol             | Test Condition               | Min    | Typ    | Max    | Unit          |
|----------------------------------|--------------------|------------------------------|--------|--------|--------|---------------|
| Oscillation frequency            | $f_{\text{LFRCO}}$ | ENVREF = 1 in CMU_LFRCCOCTRL | 30.474 | 32.768 | 34.243 | kHz           |
|                                  |                    | ENVREF = 0 in CMU_LFRCCOCTRL | 30.474 | 32.768 | 33.915 | kHz           |
| Startup time                     | $t_{\text{LFRCO}}$ |                              | —      | 500    | —      | $\mu\text{s}$ |
| Current consumption <sup>1</sup> | $I_{\text{LFRCO}}$ | ENVREF = 1 in CMU_LFRCCOCTRL | —      | 342    | —      | nA            |
|                                  |                    | ENVREF = 0 in CMU_LFRCCOCTRL | —      | 494    | —      | nA            |

**Note:**

1. Block is supplied by AVDD if ANASW = 0, or DVDD if ANASW=1 in EMU\_PWRCTRL register

#### 4.1.12.4 HFRCO and AUXHFRCO

**Table 4.34. HFRCO and AUXHFRCO**

| Parameter                           | Symbol              | Test Condition  | Min  | Typ | Max | Unit          |
|-------------------------------------|---------------------|---|------|-----|-----|---------------|
| Frequency Accuracy                  | $f_{\text{HFRCO}}$  | Any frequency band, across supply voltage and temperature | -2.5 | —   | 2.5 | %             |
| Start-up time                       | $t_{\text{HFRCO}}$  | $f_{\text{HFRCO}} \geq 19 \text{ MHz}$                    | —    | 300 | —   | ns            |
|                                     |                     | $4 < f_{\text{HFRCO}} < 19 \text{ MHz}$                   | —    | 1   | —   | $\mu\text{s}$ |
|                                     |                     | $f_{\text{HFRCO}} \leq 4 \text{ MHz}$                     | —    | 2.5 | —   | $\mu\text{s}$ |
| Current consumption on all supplies | $I_{\text{HFRCO}}$  | $f_{\text{HFRCO}} = 38 \text{ MHz}$                       | —    | 204 | 228 | $\mu\text{A}$ |
|                                     |                     | $f_{\text{HFRCO}} = 32 \text{ MHz}$                       | —    | 171 | 190 | $\mu\text{A}$ |
|                                     |                     | $f_{\text{HFRCO}} = 26 \text{ MHz}$                       | —    | 147 | 164 | $\mu\text{A}$ |
|                                     |                     | $f_{\text{HFRCO}} = 19 \text{ MHz}$                       | —    | 126 | 138 | $\mu\text{A}$ |
|                                     |                     | $f_{\text{HFRCO}} = 16 \text{ MHz}$                       | —    | 110 | 120 | $\mu\text{A}$ |
|                                     |                     | $f_{\text{HFRCO}} = 13 \text{ MHz}$                       | —    | 100 | 110 | $\mu\text{A}$ |
|                                     |                     | $f_{\text{HFRCO}} = 7 \text{ MHz}$                        | —    | 81  | 91  | $\mu\text{A}$ |
|                                     |                     | $f_{\text{HFRCO}} = 4 \text{ MHz}$                        | —    | 33  | 35  | $\mu\text{A}$ |
|                                     |                     | $f_{\text{HFRCO}} = 2 \text{ MHz}$                        | —    | 31  | 35  | $\mu\text{A}$ |
|                                     |                     | $f_{\text{HFRCO}} = 1 \text{ MHz}$                        | —    | 30  | 35  | $\mu\text{A}$ |
| Step size                           | $SS_{\text{HFRCO}}$ | Coarse (% of period)                                      | —    | 0.8 | —   | %             |
|                                     |                     | Fine (% of period)  | —    | 0.1 | —   | %             |
| Duty cycle                          | $DC_{\text{HFRCO}}$ |   | TBD  | —   | TBD | %             |
| Period Jitter                       | $PJ_{\text{HFRCO}}$ |   | —    | 0.2 | —   | % RMS         |

#### 4.1.12.5 ULFRCO

**Table 4.35. ULFRCO**

| Parameter             | Symbol              | Test Condition | Min  | Typ | Max  | Unit |
|-----------------------|---------------------|----------------|------|-----|------|------|
| Oscillation frequency | $f_{\text{ULFRCO}}$ |                | 0.95 | 1   | 1.07 | kHz  |

#### 4.1.13 Flash Memory Characteristics

**Table 4.36. Flash Memory Characteristics<sup>1</sup>**

| Parameter                                 | Symbol        | Test Condition | Min   | Typ | Max | Unit    |
|---|---------------|----------------|-------|-----|-----|---------|
| Flash erase cycles before failure         | $EC_{FLASH}$  |                | 10000 | —   | —   | cycles  |
| Flash data retention                      | $RET_{FLASH}$ |                | 10    | —   | —   | years   |
| Word (32-bit) programming time            | $t_{W\_PROG}$ |                | 20    | 26  | 40  | $\mu s$ |
| Page erase time                           | $t_{PERASE}$  |                | 20    | 27  | 40  | ms      |
| Mass erase time                           | $t_{MERASE}$  |                | 20    | 27  | 40  | ms      |
| Device erase time <sup>2</sup>            | $t_{DERASE}$  |                | —     | 60  | 74  | ms      |
| Page erase current <sup>3</sup>           | $I_{ERASE}$   |                | —     | —   | 3   | mA      |
| Mass or Device erase current <sup>3</sup> |               |                | —     | —   | 5   | mA      |
| Write current <sup>3</sup>                | $I_{WRITE}$   |                | —     | —   | 3   | mA      |

**Note:**

1. Flash data retention information is published in the Quarterly Quality and Reliability Report.
2. Device erase is issued over the AAP interface and erases all flash, SRAM, the Lock Bit (LB) page, and the User data page Lock Word (ULW)
3. Measured at 25°C

4.1.14 GPIO

Table 4.37. GPIO

| Parameter  | Symbol          | Test Condition  | Min               | Typ | Max               | Unit       |
|--|-----------------|---|-------------------|-----|-------------------|------------|
| Input low voltage  | $V_{IOIL}$      |   | —                 | —   | $IOVDD \cdot 0.3$ | V          |
| Input high voltage   | $V_{IOIH}$      |   | $IOVDD \cdot 0.7$ | —   | —                 | V          |
| Output high voltage relative to IOVDD                          | $V_{IOOH}$      | Sourcing 3 mA, $IOVDD \geq 3$ V,<br>DRIVESTRENGTH <sup>1</sup> = WEAK                 | $IOVDD \cdot 0.8$ | —   | —                 | V          |
|  |                 | Sourcing 1.2 mA, $IOVDD \geq 1.62$ V<br>DRIVESTRENGTH <sup>1</sup> = WEAK             | $IOVDD \cdot 0.6$ | —   | —                 | V          |
|  |                 | Sourcing 20 mA, $IOVDD \geq 3$ V,<br>DRIVESTRENGTH <sup>1</sup> = STRONG              | $IOVDD \cdot 0.8$ | —   | —                 | V          |
|  |                 | Sourcing 8 mA, $IOVDD \geq 1.62$ V<br>DRIVESTRENGTH <sup>1</sup> = STRONG             | $IOVDD \cdot 0.6$ | —   | —                 | V          |
| Output low voltage relative to IOVDD                           | $V_{IOOL}$      | Sinking 3 mA, $IOVDD \geq 3$ V,<br>DRIVESTRENGTH <sup>1</sup> = WEAK                  | —                 | —   | $IOVDD \cdot 0.2$ | V          |
|  |                 | Sinking 1.2 mA, $IOVDD \geq 1.62$ V<br>DRIVESTRENGTH <sup>1</sup> = WEAK              | —                 | —   | $IOVDD \cdot 0.4$ | V          |
|  |                 | Sinking 20 mA, $IOVDD \geq 3$ V,<br>DRIVESTRENGTH <sup>1</sup> = STRONG               | —                 | —   | $IOVDD \cdot 0.2$ | V          |
|  |                 | Sinking 8 mA, $IOVDD \geq 1.62$ V<br>DRIVESTRENGTH <sup>1</sup> = STRONG              | —                 | —   | $IOVDD \cdot 0.4$ | V          |
| Input leakage current  | $I_{IOLEAK}$    | All GPIO except LFXO pins, $GPIO \leq IOVDD$  | —                 | 0.1 | 30                | nA         |
|  |                 | LFXO Pins, $GPIO \leq IOVDD$  | —                 | 0.1 | 50                | nA         |
| Input leakage current on 5VTOL pads above IOVDD                | $I_{5VTOLLEAK}$ | $IOVDD < GPIO \leq IOVDD + 2$ V   | —                 | 3.3 | 15                | $\mu$ A    |
| I/O pin pull-up resistor                                       | $R_{PU}$        |   | 30                | 43  | 65                | k $\Omega$ |
| I/O pin pull-down resistor                                     | $R_{PD}$        |   | 30                | 43  | 65                | k $\Omega$ |
| Pulse width of pulses removed by the glitch suppression filter | $t_{IOGLITCH}$  |   | 20                | 25  | 35                | ns         |
| Output fall time, From 70% to 30% of $V_{IO}$                  | $t_{IOOF}$      | $C_L = 50$ pF,<br>DRIVESTRENGTH <sup>1</sup> = STRONG,<br>SLEWRATE <sup>1</sup> = 0x6 | —                 | 1.8 | —                 | ns         |
|  |                 | $C_L = 50$ pF,<br>DRIVESTRENGTH <sup>1</sup> = WEAK,<br>SLEWRATE <sup>1</sup> = 0x6   | —                 | 4.5 | —                 | ns         |

| Parameter                                     | Symbol     | Test Condition  | Min | Typ | Max | Unit |
|---|------------|---|-----|-----|-----|------|
| Output rise time, From 30% to 70% of $V_{IO}$ | $t_{IOOR}$ | $C_L = 50$ pF,<br>DRIVESTRENGTH <sup>1</sup> = STRONG,<br>SLEWRATE = 0x6 <sup>1</sup> | —   | 2.2 | —   | ns   |
|   |            | $C_L = 50$ pF,<br>DRIVESTRENGTH <sup>1</sup> = WEAK,<br>SLEWRATE <sup>1</sup> = 0x6   | —   | 7.4 | —   | ns   |
| <b>Note:</b><br>1. In GPIO_Pn_CTRL register   |            |   |     |     |     |      |

#### 4.1.15 VMON

Table 4.38. VMON

| Parameter                        | Symbol            | Test Condition                           | Min  | Typ  | Max  | Unit    |
|----------------------------------|-------------------|--|------|------|------|---------|
| VMON Supply Current              | $I_{VMON}$        | In EM0 or EM1, 1 supply monitored        | —    | 5.8  | 8.26 | $\mu$ A |
|                                  |                   | In EM0 or EM1, 4 supplies monitored      | —    | 11.8 | 16.8 | $\mu$ A |
|                                  |                   | In EM2, EM3 or EM4, 1 supply monitored   | —    | 62   | —    | nA      |
|                                  |                   | In EM2, EM3 or EM4, 4 supplies monitored | —    | 99   | —    | nA      |
| VMON Loading of Monitored Supply | $I_{SENSE}$       | In EM0 or EM1                            | —    | 2    | —    | $\mu$ A |
|                                  |                   | In EM2, EM3 or EM4                       | —    | 2    | —    | nA      |
| Threshold range                  | $V_{VMON\_RANGE}$ |  | 1.62 | —    | 3.4  | V       |
| Threshold step size              | $N_{VMON\_STESP}$ | Coarse                                   | —    | 200  | —    | mV      |
|                                  |                   | Fine                                     | —    | 20   | —    | mV      |
| Response time                    | $t_{VMON\_RES}$   | Supply drops at 1V/ $\mu$ s rate         | —    | 460  | —    | ns      |
| Hysteresis                       | $V_{VMON\_HYST}$  |  | —    | 26   | —    | mV      |

4.1.16 ADC

Table 4.39. ADC

| Parameter   | Symbol                | Test Condition  | Min        | Typ | Max               | Unit    |
|---|-----------------------|---|------------|-----|-------------------|---------|
| Resolution  | $V_{RESOLUTION}$      |   | 6          | —   | 12                | Bits    |
| Input voltage range   | $V_{ADCIN}$           | Single ended  | 0          | —   | $2 \cdot V_{REF}$ | V       |
|   |                       | Differential  | $-V_{REF}$ | —   | $V_{REF}$         | V       |
| Input range of external reference voltage, single ended and differential  | $V_{ADCREFIN\_P}$     |   | 1          | —   | $V_{AVDD}$        | V       |
| Power supply rejection <sup>1</sup>   | $PSRR_{ADC}$          | At DC   | —          | 80  | —                 | dB      |
| Analog input common mode rejection ratio  | $CMRR_{ADC}$          | At DC   | —          | 80  | —                 | dB      |
| Current from all supplies, using internal reference buffer. Continuous operation. $WARMUPMODE^2 = KEEPADCWARM$                        | $I_{ADC\_CONTINUOUS}$ | 1 Msps / 16 MHz ADCCLK,<br>$BIASPROG^3 = 0$                             | —          | 326 | TBD               | $\mu A$ |
|   |                       | 250 ksps / 4 MHz ADCCLK, $BIASPROG^3 = 6$                               | —          | 170 | —                 | $\mu A$ |
|   |                       | 62.5 ksps / 1 MHz ADCCLK,<br>$BIASPROG^3 = 15$                          | —          | 111 | —                 | $\mu A$ |
| Current from all supplies, using internal reference buffer. Duty-cycled operation. $WARMUPMODE^2 = NORMAL$                            | $I_{ADC\_NORMAL}$     | 35 ksps / 16 MHz ADCCLK,<br>$BIASPROG^3 = 0$                            | —          | 75  | —                 | $\mu A$ |
|   |                       | 5 ksps / 16 MHz ADCCLK<br>$BIASPROG^3 = 0$                              | —          | 10  | —                 | $\mu A$ |
| Current from all supplies, using internal reference buffer. Duty-cycled operation. $AWARMUPMODE^2 = KEEPINSTANDBY$ or $KEEPINSLOWACC$ | $I_{ADC\_STANDBY}$    | 125 ksps / 16 MHz ADCCLK,<br>$BIASPROG^3 = 0$                           | —          | 122 | —                 | $\mu A$ |
|   |                       | 35 ksps / 16 MHz ADCCLK,<br>$BIASPROG^3 = 0$                            | —          | 86  | —                 | $\mu A$ |
| ADC Clock Frequency   | $f_{ADCCLK}$          |   | —          | —   | 16                | MHz     |
| Throughput rate   | $f_{ADCRATE}$         |   | —          | —   | 1                 | Msps    |
| Conversion time <sup>4</sup>  | $t_{ADCCONV}$         | 6 bit   | —          | 7   | —                 | cycles  |
|   |                       | 8 bit   | —          | 9   | —                 | cycles  |
|   |                       | 12 bit  | —          | 13  | —                 | cycles  |
| Startup time of reference generator and ADC core in NORMAL mode   | $t_{ADCSTART}$        | $WARMUPMODE^2 = NORMAL$   | —          | —   | 5                 | $\mu s$ |
| From standby mode   |                       | $WARMUPMODE^2 = KEEPINSTANDBY$ or $KEEPINSLOWACC$                       | —          | —   | 1                 | $\mu s$ |
| SNDR at 1Msps and $f_{in} = 10kHz$  | $SNDR_{ADC}$          | Internal reference, 2.5 V full-scale, differential (-1.25, 1.25)        | 58         | 67  | —                 | dB      |
|   |                       | $v_{refp\_in} = 1.25$ V direct mode with 2.5 V full-scale, differential | —          | 68  | —                 | dB      |

| Parameter                                      | Symbol                    | Test Condition                              | Min | Typ   | Max | Unit  |
|--|---------------------------|---|-----|-------|-----|-------|
| Spurious-Free Dynamic Range (SFDR)             | SFDR <sub>ADC</sub>       | 1 MSamples/s, 10 kHz full-scale sine wave   | —   | 75    | —   | dB    |
| Input referred ADC noise, rms                  | V <sub>REF_NOISE</sub>    | Including quantization noise and distortion | —   | 380   | —   | μV    |
| Offset Error                                   | V <sub>ADCOFFSETERR</sub> |   | -3  | 1     | 3   | LSB   |
| Gain error in ADC                              | V <sub>ADC_GAIN</sub>     | Using internal reference                    | —   | -0.2  | 5   | %     |
|  |                           | Using external reference                    | —   | -1    | —   | %     |
| Differential non-linearity (DNL)               | DNL <sub>ADC</sub>        | 12 bit resolution                           | -1  | —     | 2   | LSB   |
| Integral non-linearity (INL), End point method | INL <sub>ADC</sub>        | 12 bit resolution                           | -6  | —     | 6   | LSB   |
| Temperature Sensor Slope                       | V <sub>TS_SLOPE</sub>     |   | —   | -1.84 | —   | mV/°C |

**Note:**

1. PSRR is referenced to AVDD when ANASW=0 and to DVDD when ANASW=1 in EMU\_PWRCTRL
2. In ADCn\_CNTL register
3. In ADCn\_BIASPROG register
4. Derived from ADCCLK



4.1.17 IDAC

Table 4.40. IDAC

| Parameter  | Symbol             | Test Condition  | Min  | Typ  | Max | Unit |
|--|--------------------|---|------|------|-----|------|
| Number of Ranges   | $N_{IDAC\_RANGES}$ |   | —    | 4    | —   | -    |
| Output Current   | $I_{IDAC\_OUT}$    | RANGESEL <sup>1</sup> = RANGE0  | 0.05 | —    | 1.6 | μA   |
|  |                    | RANGESEL <sup>1</sup> = RANGE1  | 1.6  | —    | 4.7 | μA   |
|  |                    | RANGESEL <sup>1</sup> = RANGE2  | 0.5  | —    | 16  | μA   |
|  |                    | RANGESEL <sup>1</sup> = RANGE3  | 2    | —    | 64  | μA   |
| Linear steps within each range   | $N_{IDAC\_STEPS}$  |   | —    | 32   | —   |      |
| Step size  | $SS_{IDAC}$        | RANGESEL <sup>1</sup> = RANGE0  | —    | 50   | —   | nA   |
|  |                    | RANGESEL <sup>1</sup> = RANGE1  | —    | 100  | —   | nA   |
|  |                    | RANGESEL <sup>1</sup> = RANGE2  | —    | 500  | —   | nA   |
|  |                    | RANGESEL <sup>1</sup> = RANGE3  | —    | 2    | —   | μA   |
| Total Accuracy, STEPSEL <sup>1</sup> = 0x10  | $ACC_{IDAC}$       | EM0 or EM1, AVDD=3.3 V, T = 25 °C   | -2   | —    | 2   | %    |
|  |                    | EM0 or EM1  | -18  | —    | 22  | %    |
|  |                    | EM2 or EM3  | TBD  | —    | TBD | %    |
| Start up time  | $t_{IDAC\_SU}$     | Output within 1% of steady state value                                    | —    | 5    | —   | μs   |
| Settling time, (output settled within 1% of steady state value)                                    | $t_{IDAC\_SETTLE}$ | Range setting is changed  | —    | 5    | —   | μs   |
|  |                    | Step value is changed   | —    | 1    | —   | μs   |
| Current consumption in EM0 or EM1 <sup>2</sup>   | $I_{IDAC}$         | Source mode, excluding output current                                     | —    | 8.9  | 13  | μA   |
|  |                    | Sink mode, excluding output current                                       | —    | 12   | 16  | μA   |
| Output voltage compliance in source mode, source current change relative to current sourced at 0 V | $I_{COMP\_SRC}$    | RANGESEL1=0, output voltage = $\min(V_{IOVDD}, V_{AVDD}^2-100\text{ mV})$ | —    | 0.16 | —   | %    |
|  |                    | RANGESEL1=1, output voltage = $\min(V_{IOVDD}, V_{AVDD}^2-100\text{ mV})$ | —    | 0.08 | —   | %    |
|  |                    | RANGESEL1=2, output voltage = $\min(V_{IOVDD}, V_{AVDD}^2-150\text{ mV})$ | —    | 0.03 | —   | %    |
|  |                    | RANGESEL1=3, output voltage = $\min(V_{IOVDD}, V_{AVDD}^2-250\text{ mV})$ | —    | 0.03 | —   | %    |

| Parameter   | Symbol                 | Test Condition                       | Min | Typ  | Max | Unit |
|---|------------------------|--------------------------------------|-----|------|-----|------|
| Output voltage compliance in sink mode, sink current change relative to current sunk at IOVDD | I <sub>COMP_SINK</sub> | RANGESEL1=0, output voltage = 100 mV | —   | 0.82 | —   | %    |
|   |                        | RANGESEL1=1, output voltage = 100 mV | —   | 0.65 | —   | %    |
|   |                        | RANGESEL1=2, output voltage = 150 mV | —   | 0.4  | —   | %    |
|   |                        | RANGESEL1=3, output voltage = 250 mV | —   | 0.25 | —   | %    |

**Note:**

1. In IDAC\_CURPROG register
2. The IDAC is supplied by either AVDD, DVDD, or IOVDD based on the setting of ANASW in the EMU\_PWRCTRL register and PWRSEL in the IDAC\_CTRL register. Setting PWRSEL to 1 selects IOVDD. With PWRSEL cleared to 0, ANASW selects between AVDD (0) and DVDD (1).

4.1.18 Analog Comparator (ACMP)

Table 4.41. ACMP

| Parameter  | Symbol         | Test Condition   | Min   | Typ | Max                | Unit |
|--|----------------|--|-------|-----|--------------------|------|
| Input voltage range  | $V_{ACMPIN}$   | CMPVDD =<br>ACMPn_CTRL_PWRSEL <sup>1</sup>                           | 0     | —   | CMPVDD             | V    |
| Supply Voltage   | $V_{ACMPVDD}$  | BIASPROG <sup>2</sup> ≤ 0x10 or FULL-<br>BIAS <sup>2</sup> = 0       | 1.85  | —   | $V_{VREGVDD\_MAX}$ | V    |
|  |                | 0x10 < BIASPROG <sup>2</sup> ≤ 0x20 and<br>FULLBIAS <sup>2</sup> = 1 | 2.1   | —   | $V_{VREGVDD\_MAX}$ | V    |
| Active current not including<br>voltage reference  | $I_{ACMP}$     | BIASPROG <sup>2</sup> = 1, FULLBIAS <sup>2</sup> = 0                 | —     | 50  | —                  | nA   |
|  |                | BIASPROG <sup>2</sup> = 0x10, FULLBIAS <sup>2</sup><br>= 0           | —     | 306 | —                  | nA   |
|  |                | BIASPROG <sup>2</sup> = 0x20, FULLBIAS <sup>2</sup><br>= 1           | —     | 74  | 95                 | μA   |
| Current consumption of inter-<br>nal voltage reference   | $I_{ACMPREF}$  | VLP selected as input using 2.5 V<br>Reference / 4 (0.625 V)         | —     | 50  | —                  | nA   |
|  |                | VLP selected as input using VDD                                      | —     | 20  | —                  | nA   |
|  |                | VBDIV selected as input using<br>1.25 V reference / 1                | —     | 4.1 | —                  | μA   |
|  |                | VADIV selected as input using<br>VDD/1                               | —     | 2.4 | —                  | μA   |
| Hysteresis ( $V_{CM} = 1.25$ V,<br>BIASPROG <sup>2</sup> = 0x10, FULL-<br>BIAS <sup>2</sup> = 1) | $V_{ACMPHYST}$ | HYSTSEL <sup>3</sup> = HYST0   | -1.75 | 0   | 1.75               | mV   |
|  |                | HYSTSEL <sup>3</sup> = HYST1   | 10    | 18  | 26                 | mV   |
|  |                | HYSTSEL <sup>3</sup> = HYST2   | 21    | 32  | 46                 | mV   |
|  |                | HYSTSEL <sup>3</sup> = HYST3   | 27    | 44  | 63                 | mV   |
|  |                | HYSTSEL <sup>3</sup> = HYST4   | 32    | 55  | 80                 | mV   |
|  |                | HYSTSEL <sup>3</sup> = HYST5   | 38    | 65  | 100                | mV   |
|  |                | HYSTSEL <sup>3</sup> = HYST6   | 43    | 77  | 121                | mV   |
|  |                | HYSTSEL <sup>3</sup> = HYST7   | 47    | 86  | 148                | mV   |
|  |                | HYSTSEL <sup>3</sup> = HYST8   | -4    | 0   | 4                  | mV   |
|  |                | HYSTSEL <sup>3</sup> = HYST9   | -27   | -18 | -10                | mV   |
|  |                | HYSTSEL <sup>3</sup> = HYST10  | -47   | -32 | -18                | mV   |
|  |                | HYSTSEL <sup>3</sup> = HYST11  | -64   | -43 | -27                | mV   |
|  |                | HYSTSEL <sup>3</sup> = HYST12  | -78   | -54 | -32                | mV   |
|  |                | HYSTSEL <sup>3</sup> = HYST13  | -93   | -64 | -37                | mV   |
|  |                | HYSTSEL <sup>3</sup> = HYST14  | -113  | -74 | -42                | mV   |
| HYSTSEL <sup>3</sup> = HYST15  | -135           | -85  | -47   | mV  |                    |      |

| Parameter                            | Symbol           | Test Condition  | Min | Typ  | Max  | Unit          |
|--------------------------------------|------------------|---|-----|------|------|---------------|
| Comparator delay <sup>4</sup>        | $t_{ACMPDELAY}$  | BIASPROG <sup>2</sup> = 1, FULLBIAS <sup>2</sup> = 0    | —   | 30   | —    | $\mu\text{s}$ |
|                                      |                  | BIASPROG <sup>2</sup> = 0x10, FULLBIAS <sup>2</sup> = 0 | —   | 3.7  | —    | $\mu\text{s}$ |
|                                      |                  | BIASPROG <sup>2</sup> = 0x20, FULLBIAS <sup>2</sup> = 1 | —   | 35   | —    | ns            |
| Offset voltage                       | $V_{ACMPOFFSET}$ | BIASPROG <sup>2</sup> = 0x10, FULLBIAS <sup>2</sup> = 1 | -35 | —    | 35   | mV            |
| Reference Voltage                    | $V_{ACMPREF}$    | Internal 1.25 V reference                               | 1   | 1.25 | 1.47 | V             |
|                                      |                  | Internal 2.5 V reference                                | 2   | 2.5  | 2.8  | V             |
| Capacitive Sense Internal Resistance | $R_{CSRES}$      | CSRESSEL <sup>5</sup> = 0                               | —   | inf  | —    | k $\Omega$    |
|                                      |                  | CSRESSEL <sup>5</sup> = 1                               | —   | 15   | —    | k $\Omega$    |
|                                      |                  | CSRESSEL <sup>5</sup> = 2                               | —   | 27   | —    | k $\Omega$    |
|                                      |                  | CSRESSEL <sup>5</sup> = 3                               | —   | 39   | —    | k $\Omega$    |
|                                      |                  | CSRESSEL <sup>5</sup> = 4                               | —   | 51   | —    | k $\Omega$    |
|                                      |                  | CSRESSEL <sup>5</sup> = 5                               | —   | 102  | —    | k $\Omega$    |
|                                      |                  | CSRESSEL <sup>5</sup> = 6                               | —   | 164  | —    | k $\Omega$    |
|                                      |                  | CSRESSEL <sup>5</sup> = 7                               | —   | 239  | —    | k $\Omega$    |

**Note:**

1. CMPVDD is a supply chosen by the setting in ACMPn\_CTRL\_PWRSEL and may be IOVDD, AVDD or DVDD
2. In ACMPn\_CTRL register
3. In ACMPn\_HYSTERESIS register
4.  $\pm 100$  mV differential drive
5. In ACMPn\_INPUTSEL register

The total ACMP current is the sum of the contributions from the ACMP and its internal voltage reference as given as:

$$I_{ACMPTOTAL} = I_{ACMP} + I_{ACMPREF}$$

$I_{ACMPREF}$  is zero if an external voltage reference is used.

4.1.19 I2C

I2C Standard-mode (Sm)

Table 4.42. I2C Standard-mode (Sm)<sup>1</sup>

| Parameter  | Symbol              | Test Condition | Min | Typ | Max  | Unit |
|--|---------------------|----------------|-----|-----|------|------|
| SCL clock frequency <sup>2</sup>                 | f <sub>SCL</sub>    |                | 0   | —   | 100  | kHz  |
| SCL clock low time                               | t <sub>LOW</sub>    |                | 4.7 | —   | —    | μs   |
| SCL clock high time                              | t <sub>HIGH</sub>   |                | 4   | —   | —    | μs   |
| SDA set-up time                                  | t <sub>SU,DAT</sub> |                | 250 | —   | —    | ns   |
| SDA hold time <sup>3</sup>                       | t <sub>HD,DAT</sub> |                | 100 | —   | 3450 | ns   |
| Repeated START condition set-up time             | t <sub>SU,STA</sub> |                | 4.7 | —   | —    | μs   |
| (Repeated) START condition hold time             | t <sub>HD,STA</sub> |                | 4   | —   | —    | μs   |
| STOP condition set-up time                       | t <sub>SU,STO</sub> |                | 4   | —   | —    | μs   |
| Bus free time between a STOP and START condition | t <sub>BUF</sub>    |                | 4.7 | —   | —    | μs   |

**Note:**

1. For CLHR set to 0 in the I2Cn\_CTRL register
2. For the minimum HPPERCLK frequency required in Standard-mode, refer to the I2C chapter in the reference manual
3. The maximum SDA hold time (t<sub>HD,DAT</sub>) needs to be met only when the device does not stretch the low time of SCL (t<sub>LOW</sub>)

## I2C Fast-mode (Fm)

**Table 4.43. I2C Fast-mode (Fm)<sup>1</sup>**

| Parameter  | Symbol              | Test Condition | Min | Typ | Max | Unit |
|--|---------------------|----------------|-----|-----|-----|------|
| SCL clock frequency <sup>2</sup>                 | f <sub>SCL</sub>    |                | 0   | —   | 400 | kHz  |
| SCL clock low time                               | t <sub>LOW</sub>    |                | 1.3 | —   | —   | μs   |
| SCL clock high time                              | t <sub>HIGH</sub>   |                | 0.6 | —   | —   | μs   |
| SDA set-up time                                  | t <sub>SU,DAT</sub> |                | 100 | —   | —   | ns   |
| SDA hold time <sup>3</sup>                       | t <sub>HD,DAT</sub> |                | 100 | —   | 900 | ns   |
| Repeated START condition set-up time             | t <sub>SU,STA</sub> |                | 0.6 | —   | —   | μs   |
| (Repeated) START condition hold time             | t <sub>HD,STA</sub> |                | 0.6 | —   | —   | μs   |
| STOP condition set-up time                       | t <sub>SU,STO</sub> |                | 0.6 | —   | —   | μs   |
| Bus free time between a STOP and START condition | t <sub>BUF</sub>    |                | 1.3 | —   | —   | μs   |

**Note:**

1. For CLHR set to 1 in the I2Cn\_CTRL register
2. For the minimum HFPERCLK frequency required in Fast-mode, refer to the I2C chapter in the reference manual
3. The maximum SDA hold time (t<sub>HD,DAT</sub>) needs to be met only when the device does not stretch the low time of SCL (t<sub>LOW</sub>)

## I2C Fast-mode Plus (Fm+)

**Table 4.44. I2C Fast-mode Plus (Fm+)<sup>1</sup>**

| Parameter  | Symbol              | Test Condition | Min  | Typ | Max  | Unit |
|--|---------------------|----------------|------|-----|------|------|
| SCL clock frequency <sup>2</sup>                 | f <sub>SCL</sub>    |                | 0    | —   | 1000 | kHz  |
| SCL clock low time                               | t <sub>LOW</sub>    |                | 0.5  | —   | —    | μs   |
| SCL clock high time                              | t <sub>HIGH</sub>   |                | 0.26 | —   | —    | μs   |
| SDA set-up time                                  | t <sub>SU,DAT</sub> |                | 50   | —   | —    | ns   |
| SDA hold time                                    | t <sub>HD,DAT</sub> |                | 100  | —   | —    | ns   |
| Repeated START condition set-up time             | t <sub>SU,STA</sub> |                | 0.26 | —   | —    | μs   |
| (Repeated) START condition hold time             | t <sub>HD,STA</sub> |                | 0.26 | —   | —    | μs   |
| STOP condition set-up time                       | t <sub>SU,STO</sub> |                | 0.26 | —   | —    | μs   |
| Bus free time between a STOP and START condition | t <sub>BUF</sub>    |                | 0.5  | —   | —    | μs   |

**Note:**

1. For CLHR set to 0 or 1 in the I2Cn\_CTRL register
2. For the minimum HFPERCLK frequency required in Fast-mode Plus, refer to the I2C chapter in the reference manual

### 4.1.20 USART SPI

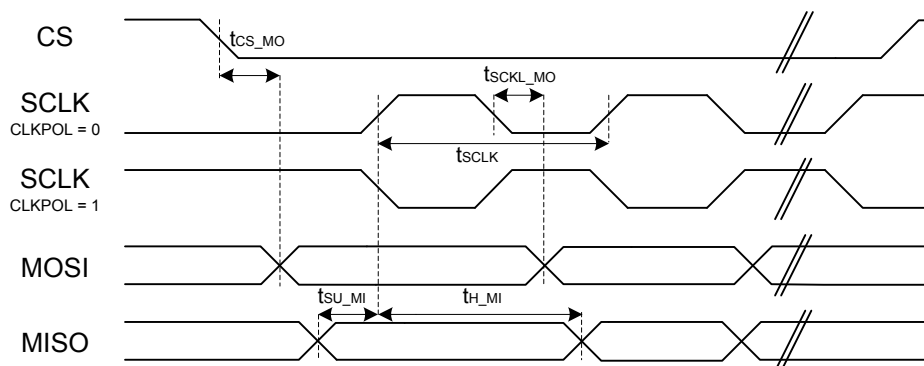
#### SPI Master Timing

**Table 4.45. SPI Master Timing**

| Parameter                      | Symbol         | Test Condition | Min                | Typ | Max | Unit |
|--------------------------------|----------------|----------------|--------------------|-----|-----|------|
| SCLK period <sup>1 2</sup>     | $t_{SCLK}$     |                | 2 * $t_{HFPERCLK}$ | —   | —   | ns   |
| CS to MOSI <sup>1 2</sup>      | $t_{CS\_MO}$   |                | 0                  | —   | 8   | ns   |
| SCLK to MOSI <sup>1 2</sup>    | $t_{SCLK\_MO}$ |                | 3                  | —   | 20  | ns   |
| MISO setup time <sup>1 2</sup> | $t_{SU\_MI}$   | IOVDD = 1.62 V | 56                 | —   | —   | ns   |
|                                |                | IOVDD = 3.0 V  | 37                 | —   | —   | ns   |
| MISO hold time <sup>1 2</sup>  | $t_{H\_MI}$    |                | 6                  | —   | —   | ns   |

**Note:**

1. Applies for both CLKPHA = 0 and CLKPHA = 1 (figure only shows CLKPHA = 0)
2. Measurement done with 8 pF output loading at 10% and 90% of  $V_{DD}$  (figure shows 50% of  $V_{DD}$ )



**Figure 4.1. SPI Master Timing Diagram**

SPI Slave Timing

Table 4.46. SPI Slave Timing

| Parameter                         | Symbol            | Test Condition | Min                       | Typ | Max                        | Unit |
|-----------------------------------|-------------------|----------------|---------------------------|-----|----------------------------|------|
| SCKL period <sup>1 2</sup>        | $t_{SCLK\_sl}$    |                | 2 *<br>$t_{HFPERCLK}$     | —   | —                          | ns   |
| SCLK high period <sup>1 2</sup>   | $t_{SCLK\_hi}$    |                | 3 *<br>$t_{HFPERCLK}$     | —   | —                          | ns   |
| SCLK low period <sup>1 2</sup>    | $t_{SCLK\_lo}$    |                | 3 *<br>$t_{HFPERCLK}$     | —   | —                          | ns   |
| CS active to MISO <sup>1 2</sup>  | $t_{CS\_ACT\_MI}$ |                | 4                         | —   | 50                         | ns   |
| CS disable to MISO <sup>1 2</sup> | $t_{CS\_DIS\_MI}$ |                | 4                         | —   | 50                         | ns   |
| MOSI setup time <sup>1 2</sup>    | $t_{SU\_MO}$      |                | 4                         | —   | —                          | ns   |
| MOSI hold time <sup>1 2</sup>     | $t_{H\_MO}$       |                | 3 + 2 *<br>$t_{HFPERCLK}$ | —   | —                          | ns   |
| SCLK to MISO <sup>1 2</sup>       | $t_{SCLK\_MI}$    |                | 16 +<br>$t_{HFPERCLK}$    | —   | 66 + 2 *<br>$t_{HFPERCLK}$ | ns   |

**Note:**

1. Applies for both CLKPHA = 0 and CLKPHA = 1 (figure only shows CLKPHA = 0)
2. Measurement done with 8 pF output loading at 10% and 90% of  $V_{DD}$  (figure shows 50% of  $V_{DD}$ )

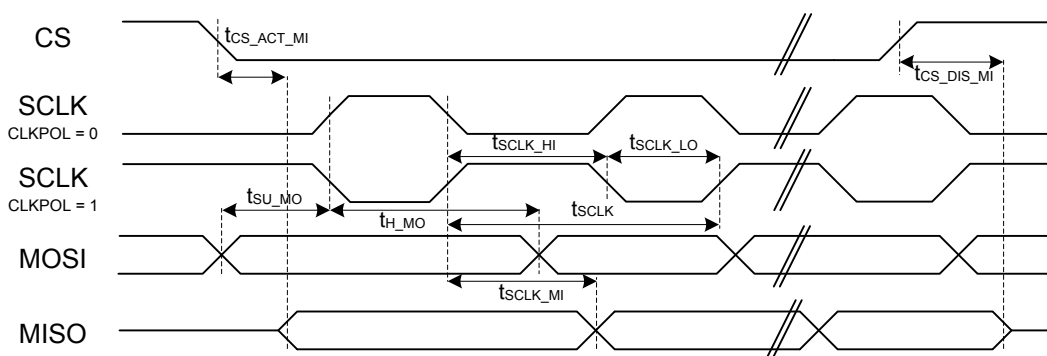


Figure 4.2. SPI Slave Timing Diagram

4.2 Typical Performance Curves

Typical performance curves indicate typical characterized performance under the stated conditions.



### 4.2.1 Supply Current

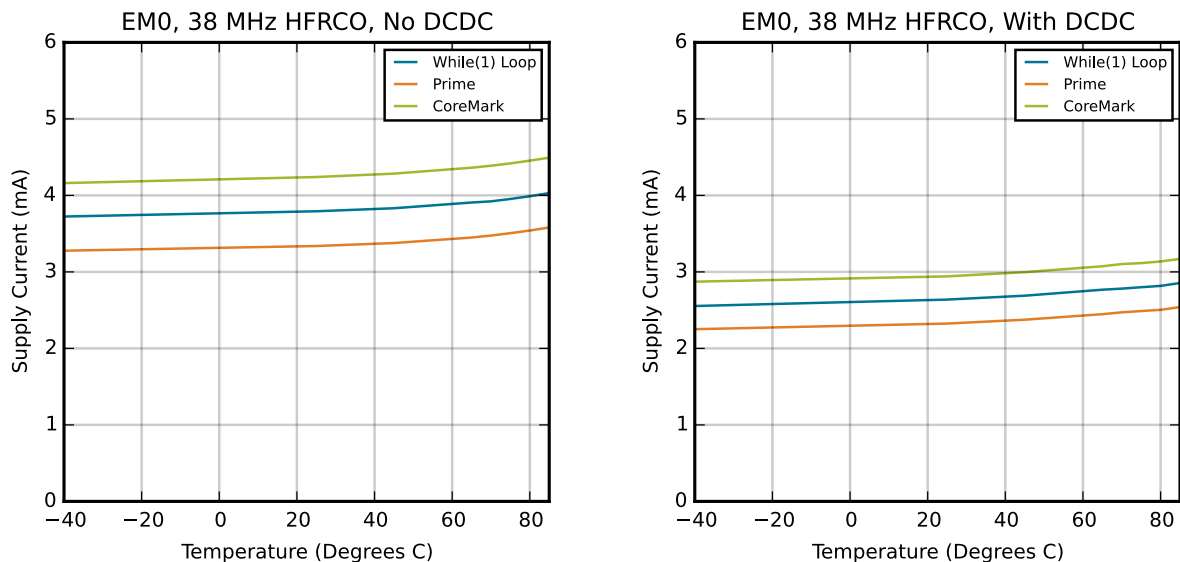


Figure 4.3. EM0 Active Mode Typical Supply Current

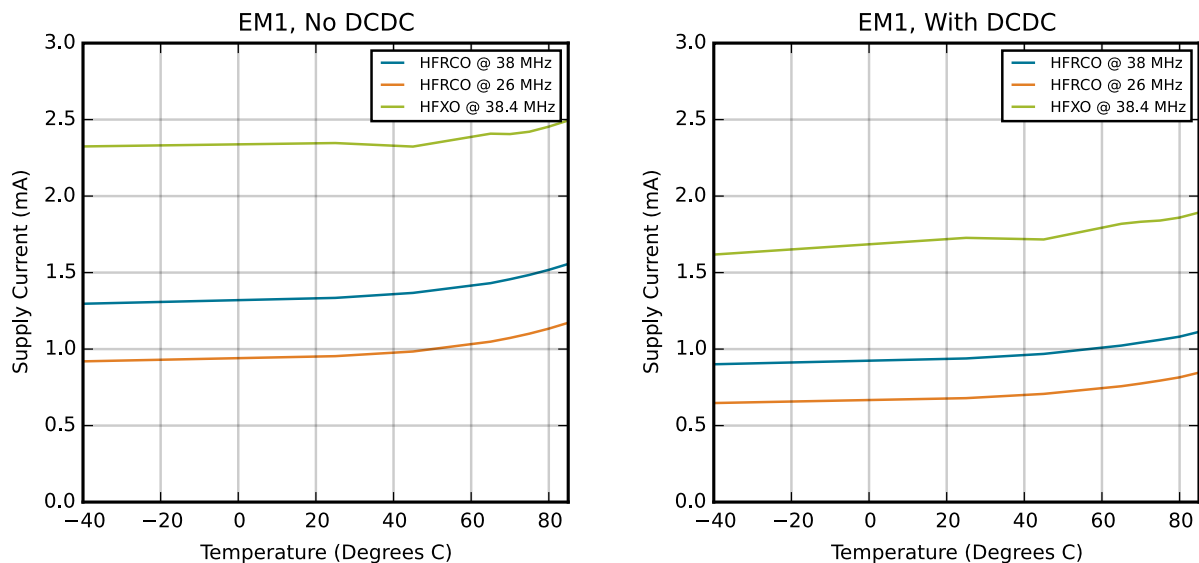


Figure 4.4. EM1 Sleep Mode Typical Supply Current

Typical supply current for EM2, EM3 and EM4H using standard software libraries from Silicon Laboratories.

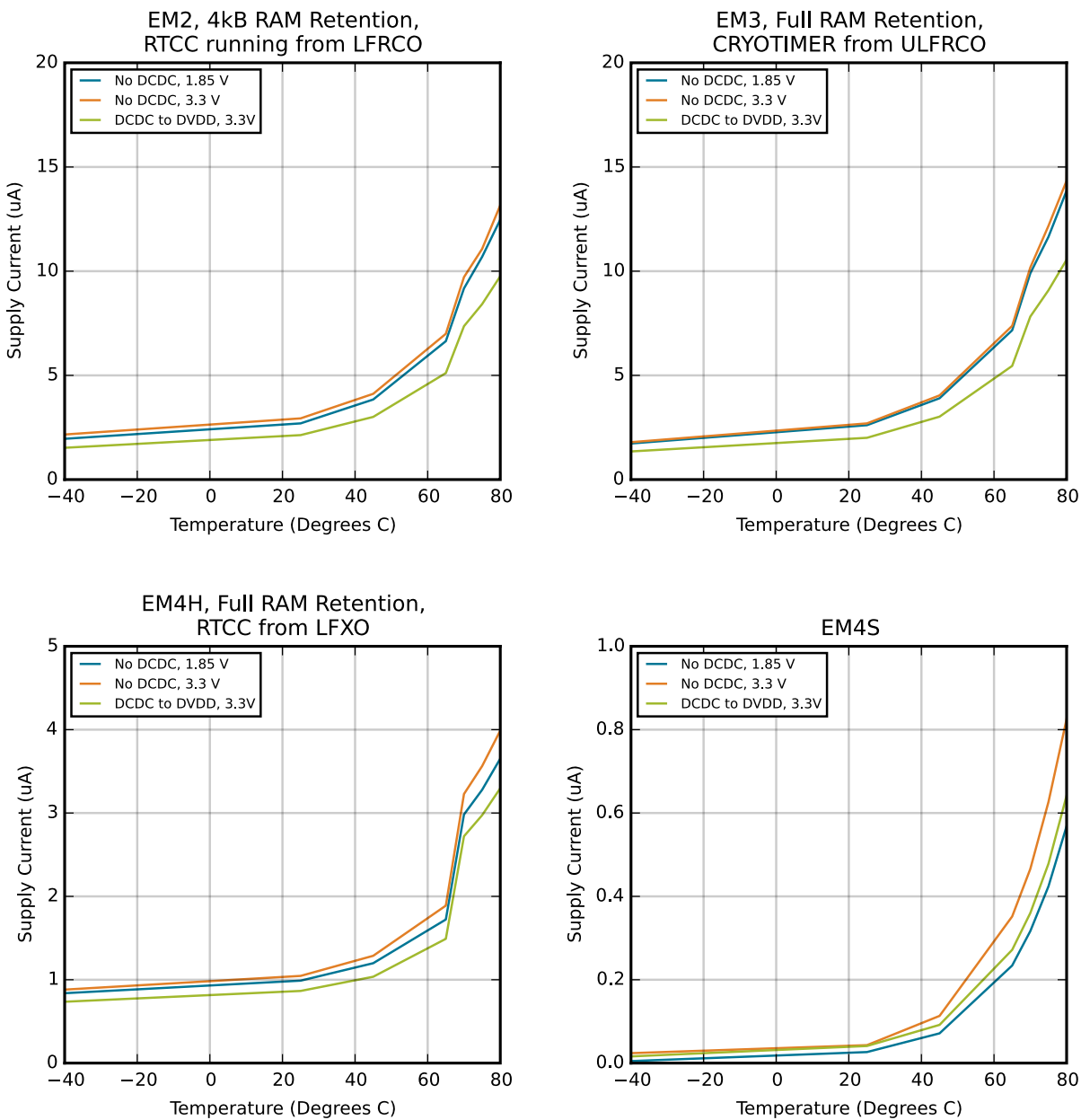


Figure 4.5. EM2, EM3, EM4H and EM4S Typical Supply Current

### 4.2.2 DC-DC Converter

Default test conditions: CCM mode, LDCDC = 4.7  $\mu$ H, CDCDC = 1.0  $\mu$ F, VDCDC\_I = 3.3 V, VDCDC\_O = 1.8 V, FDCDC\_LN = 7 MHz

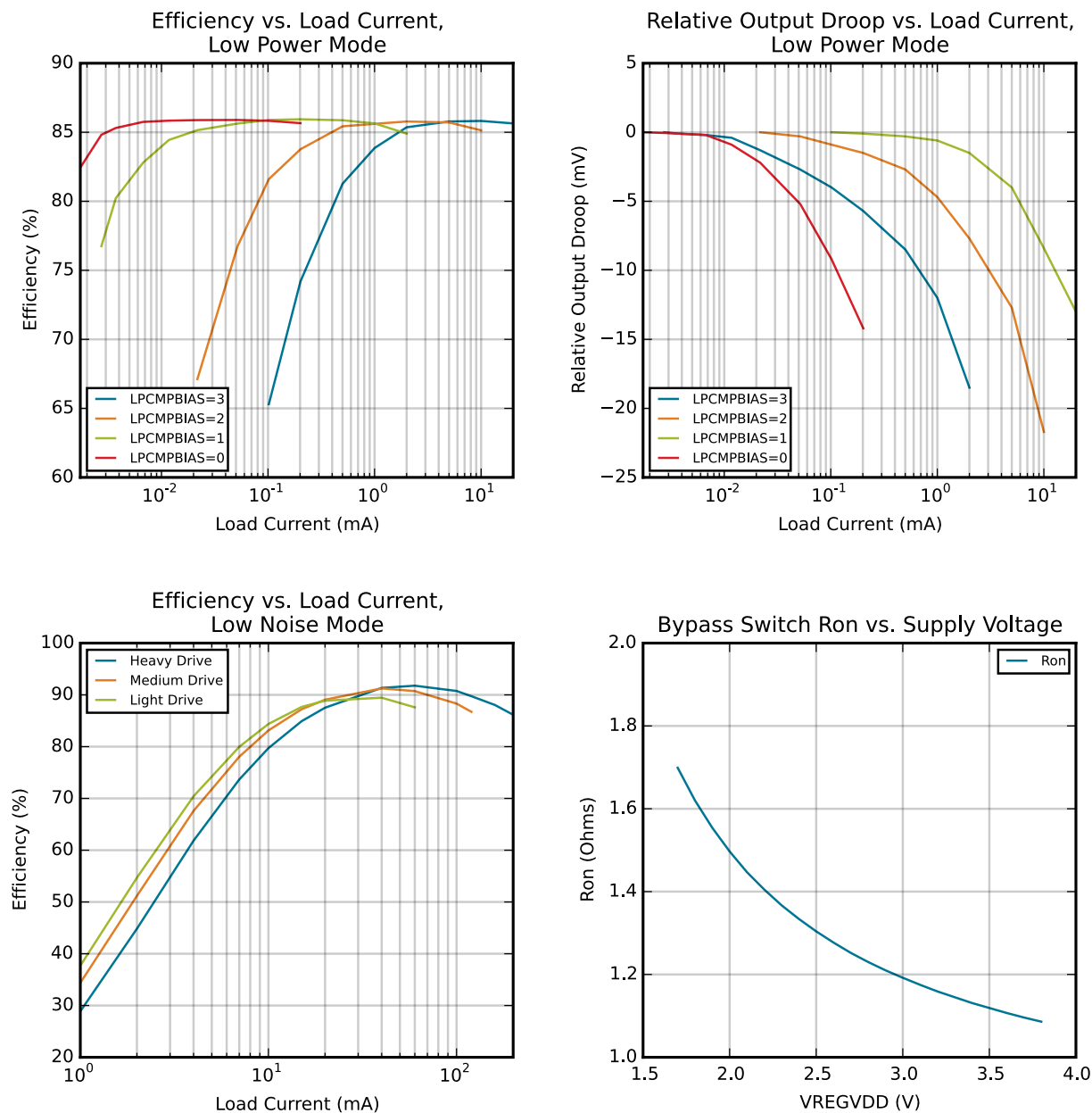


Figure 4.6. DC-DC Converter Typical Performance Characteristics

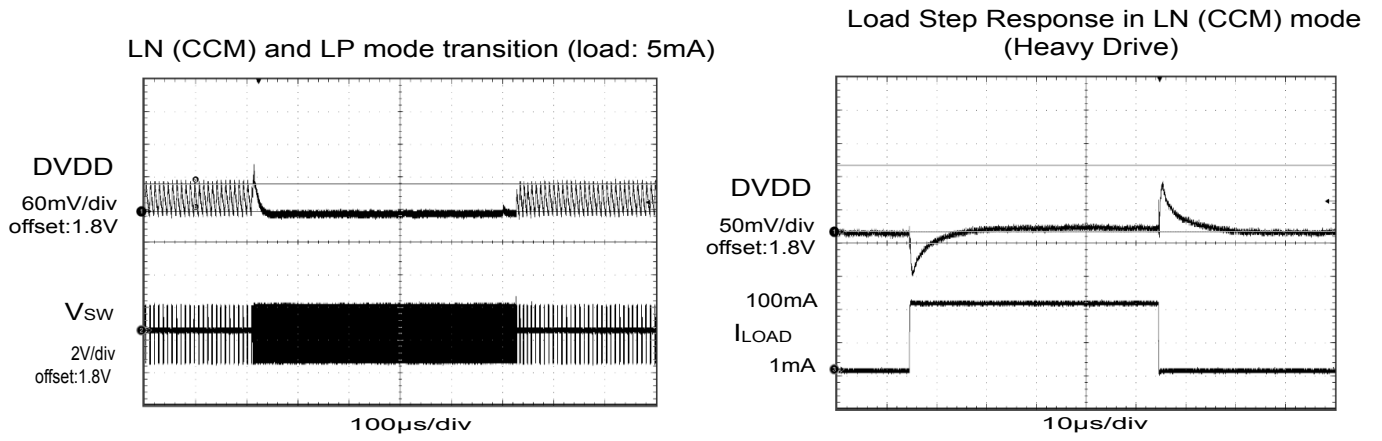


Figure 4.7. DC-DC Converter Transition Waveforms

### 4.2.3 Internal Oscillators

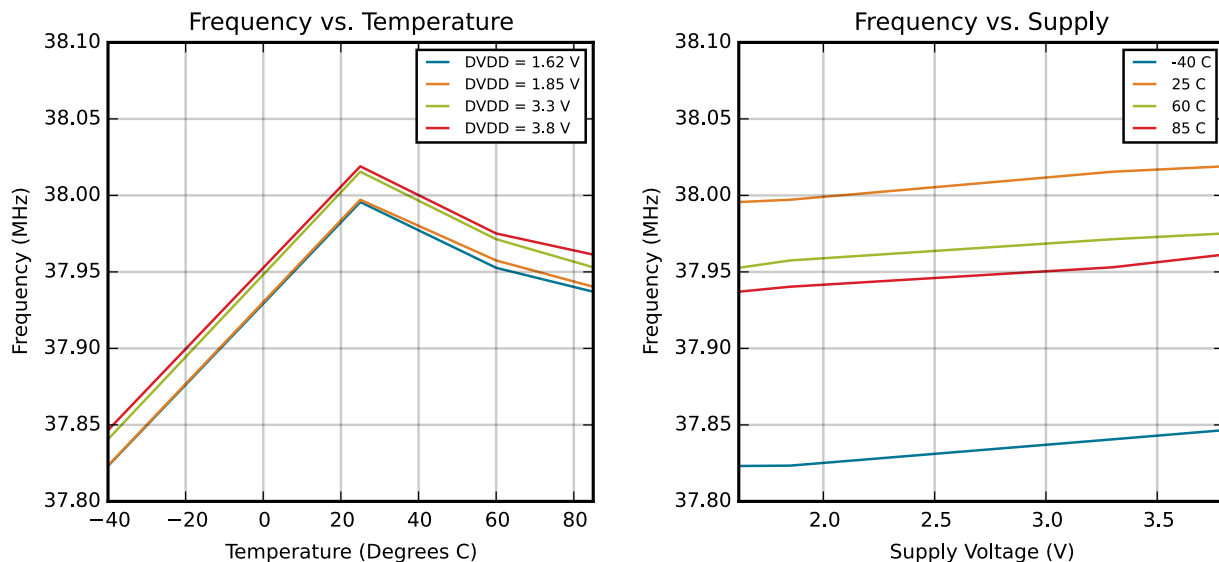


Figure 4.8. HFRCO and AUXHFRCO Typical Performance at 38 MHz

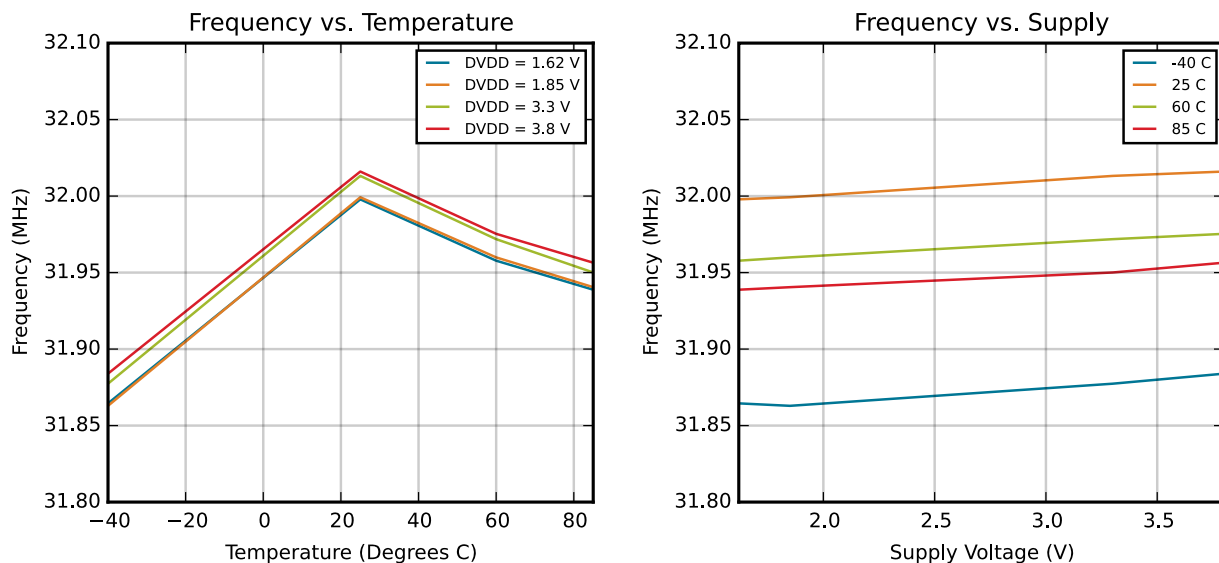
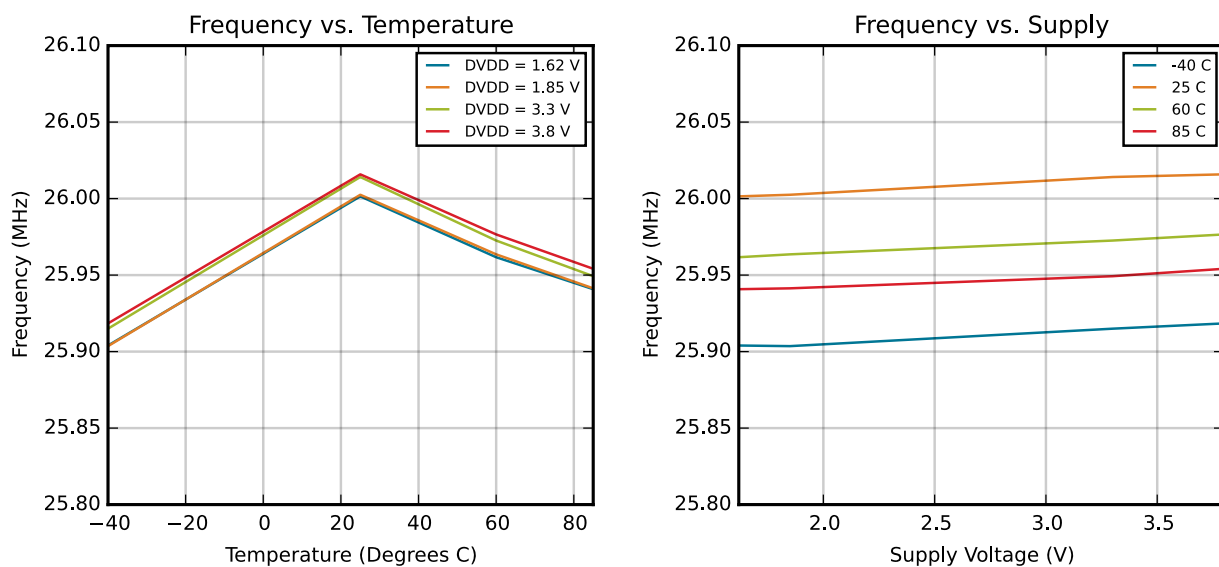
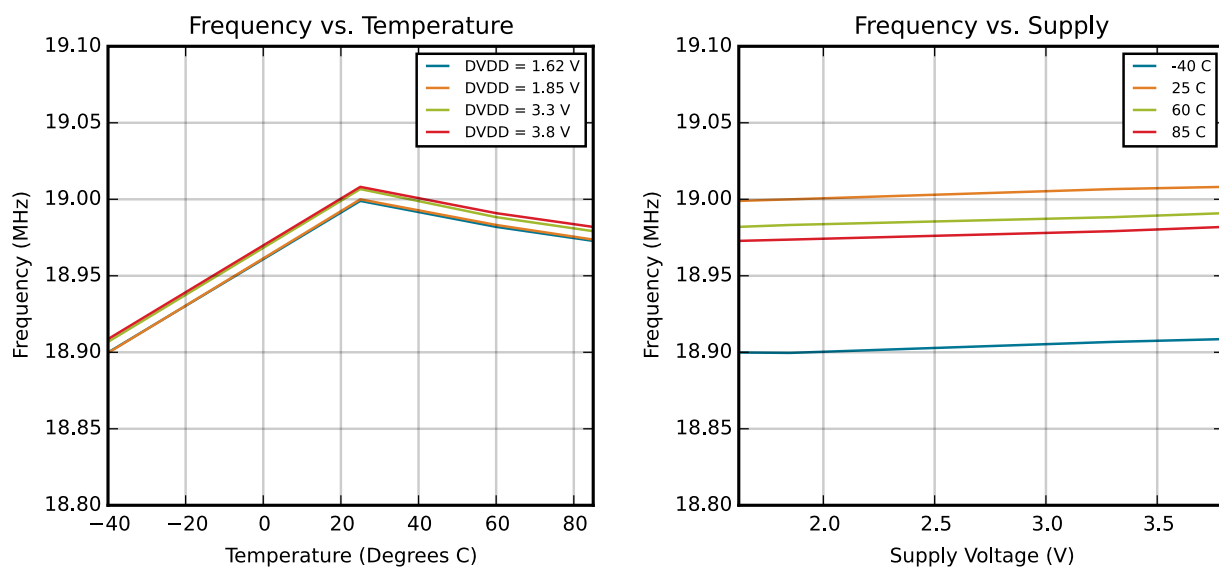


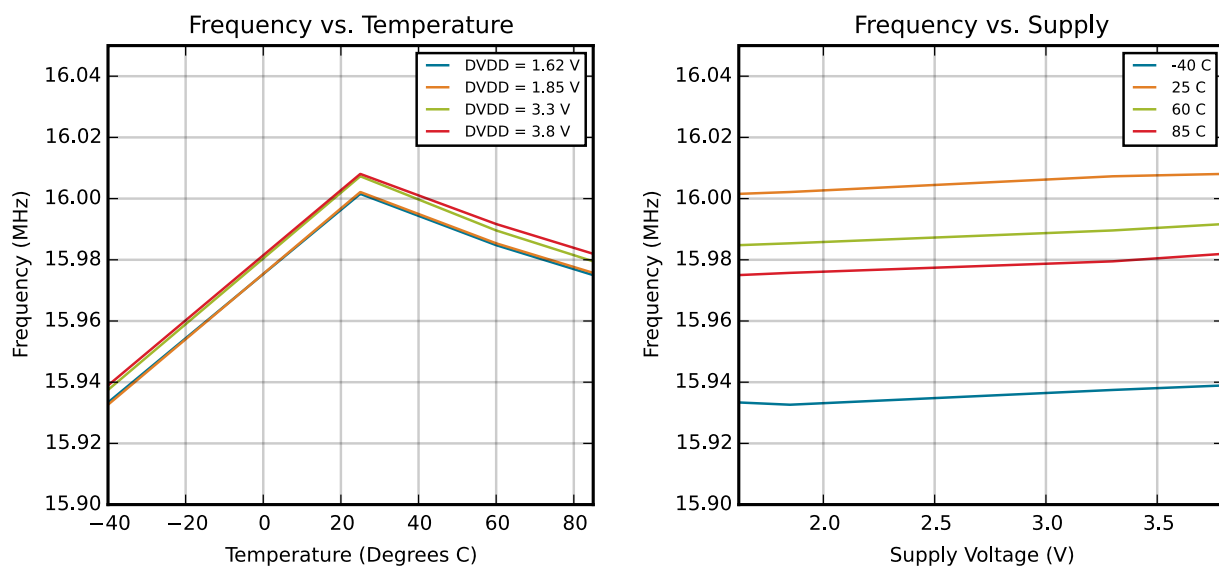
Figure 4.9. HFRCO and AUXHFRCO Typical Performance at 32 MHz



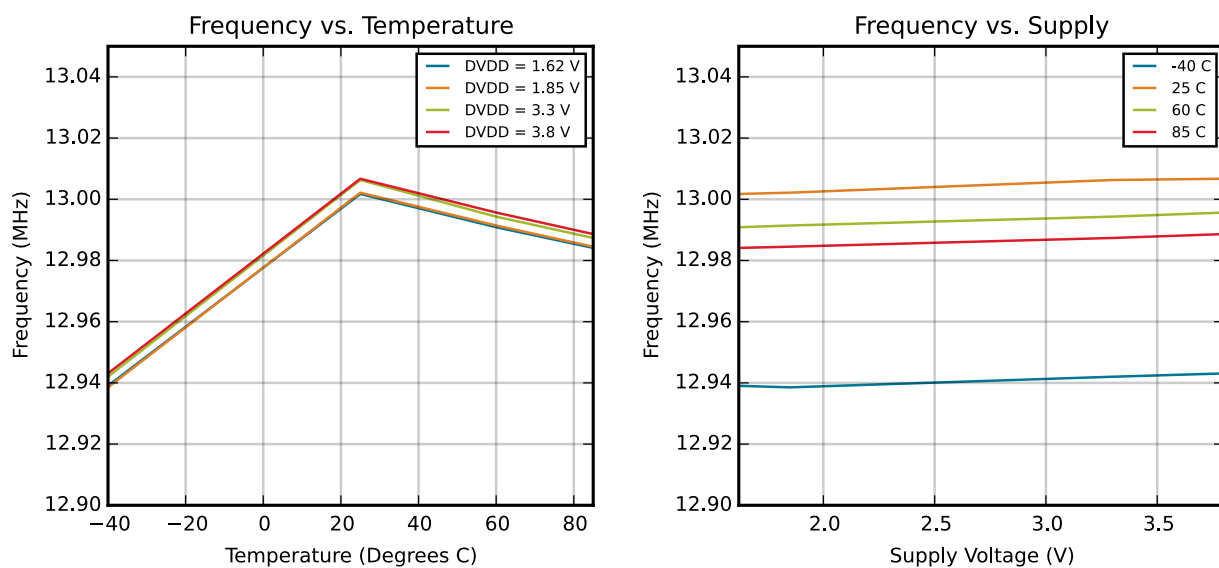
**Figure 4.10. HFRCO and AUXHFRCO Typical Performance at 26 MHz**



**Figure 4.11. HFRCO and AUXHFRCO Typical Performance at 19 MHz**



**Figure 4.12. HFRCO and AUXHFRCO Typical Performance at 16 MHz**



**Figure 4.13. HFRCO and AUXHFRCO Typical Performance at 13 MHz**

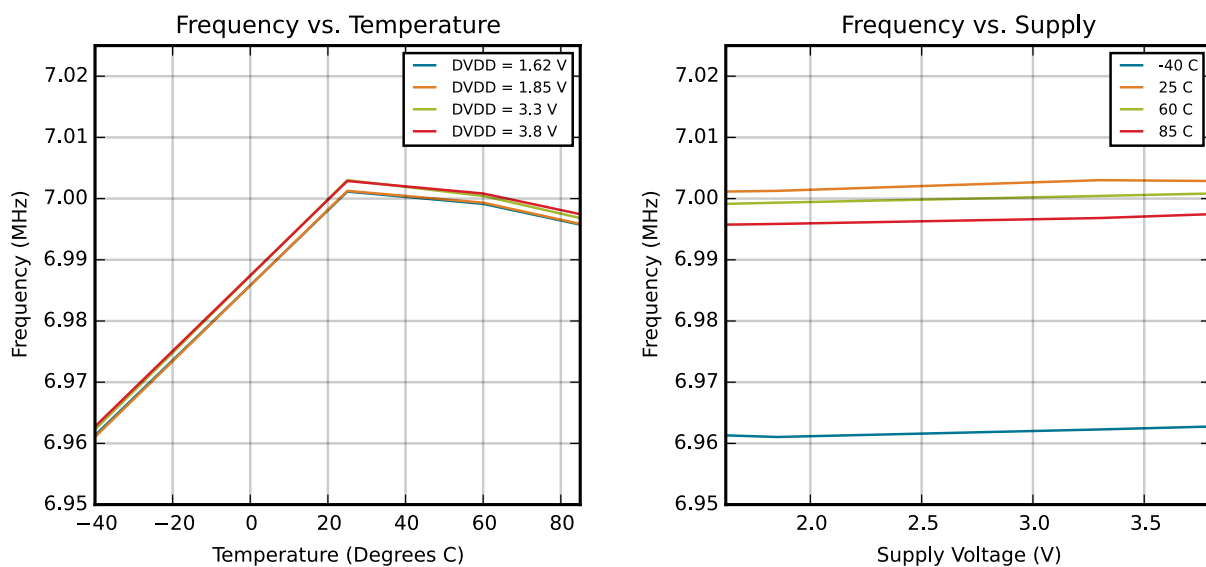


Figure 4.14. HFRCO and AUXHFRCO Typical Performance at 7 MHz

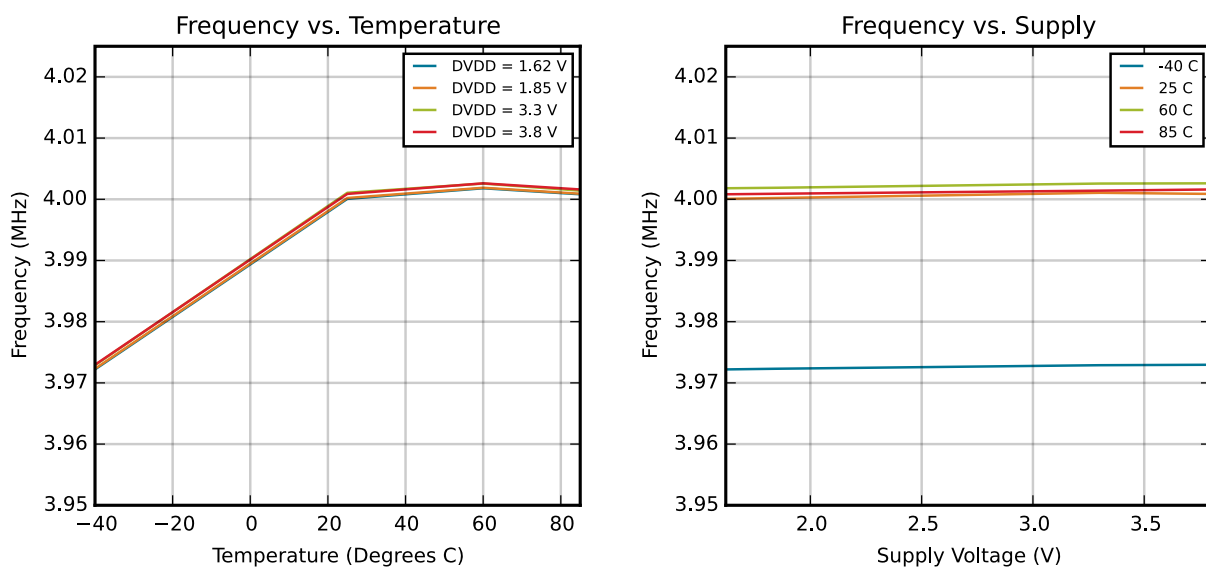
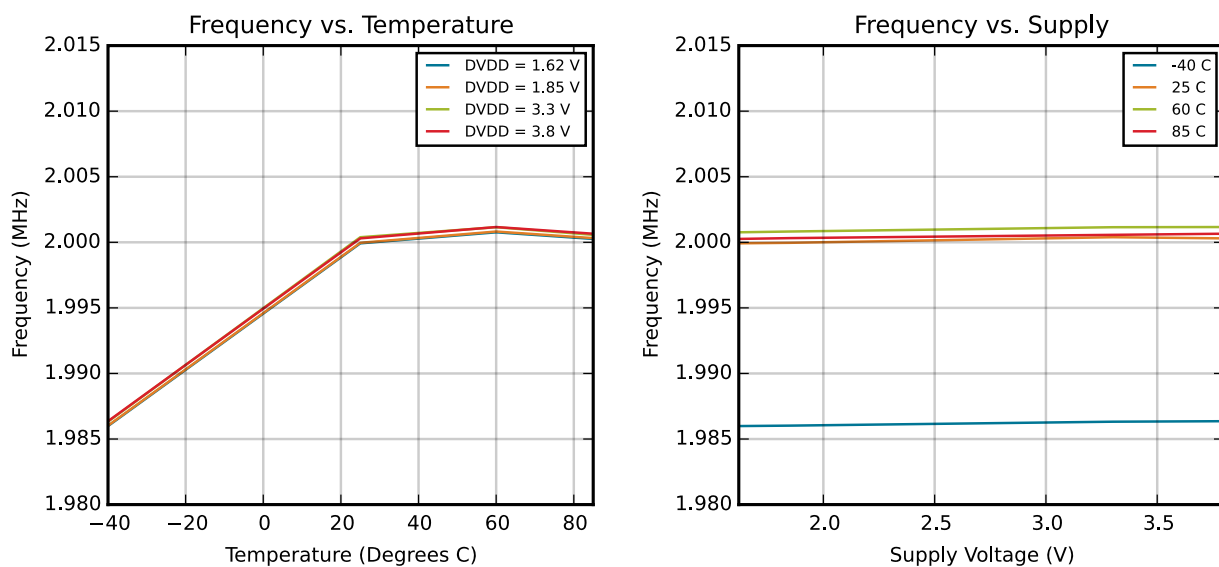
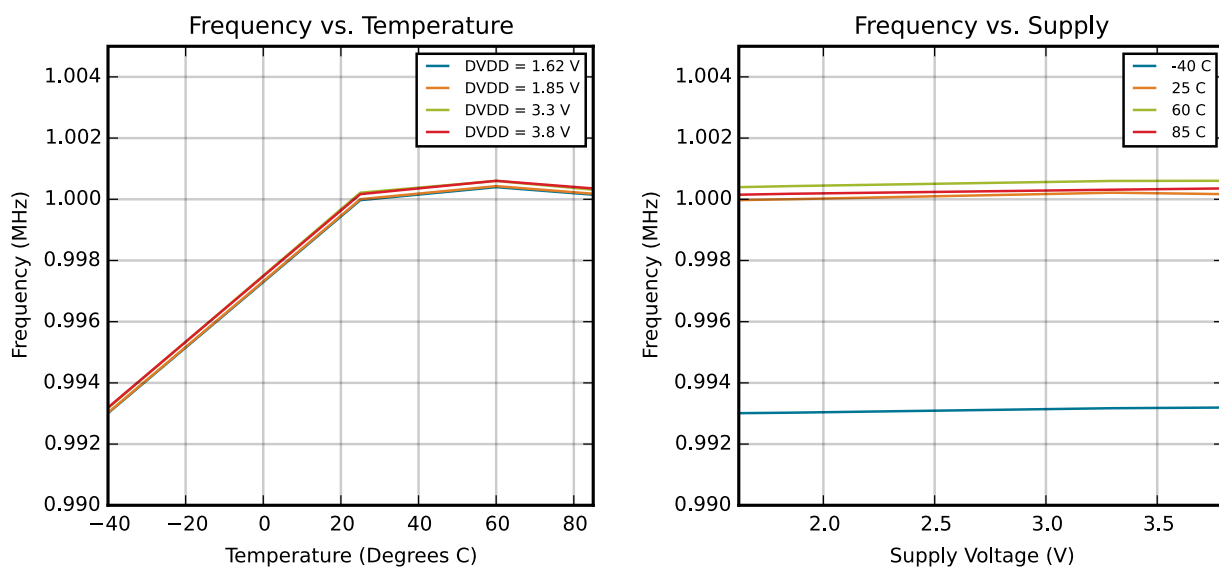


Figure 4.15. HFRCO and AUXHFRCO Typical Performance at 4 MHz





**Figure 4.16. HFRCO and AUXHFRCO Typical Performance at 2 MHz**



**Figure 4.17. HFRCO and AUXHFRCO Typical Performance at 1 MHz**

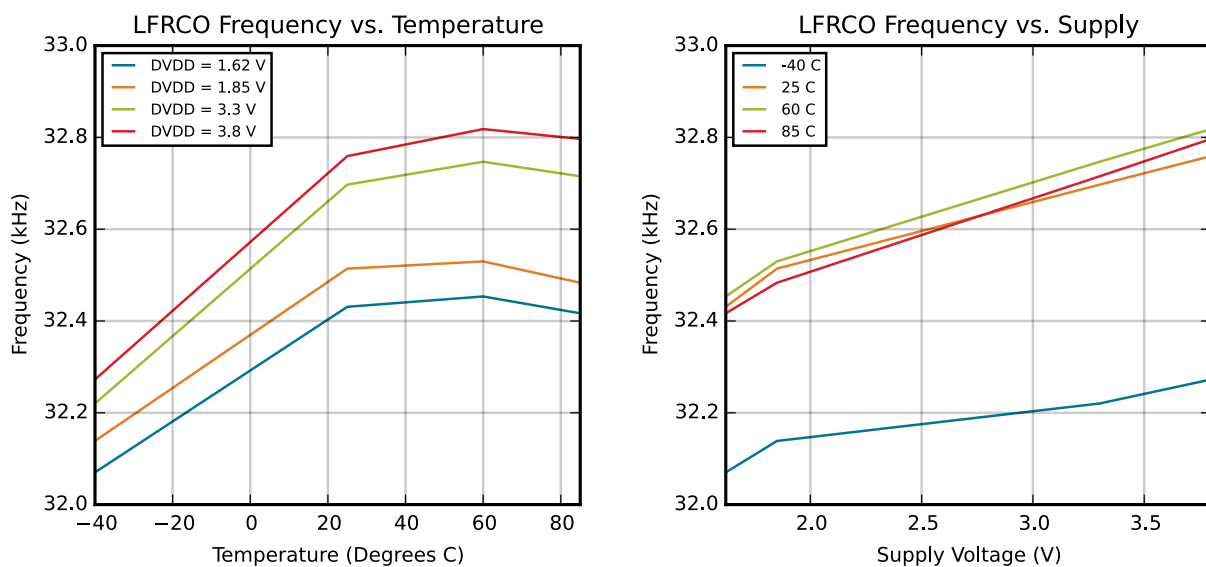


Figure 4.18. LFRCO Typical Performance at 32.768 kHz

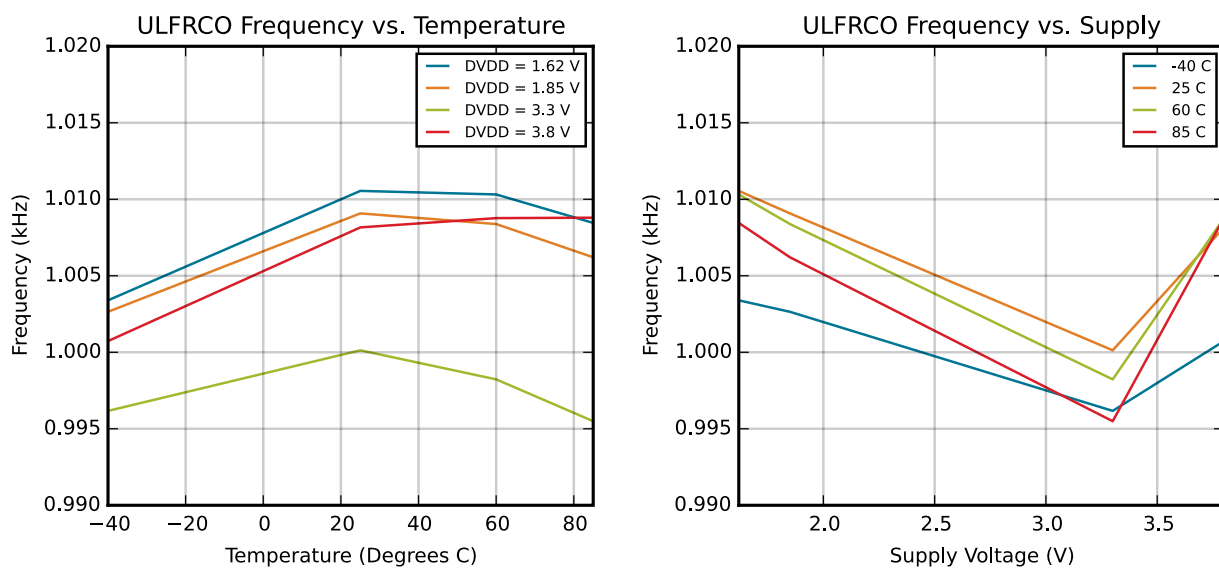


Figure 4.19. ULFRCO Typical Performance at 1 kHz

4.2.4 2.4 GHz Radio

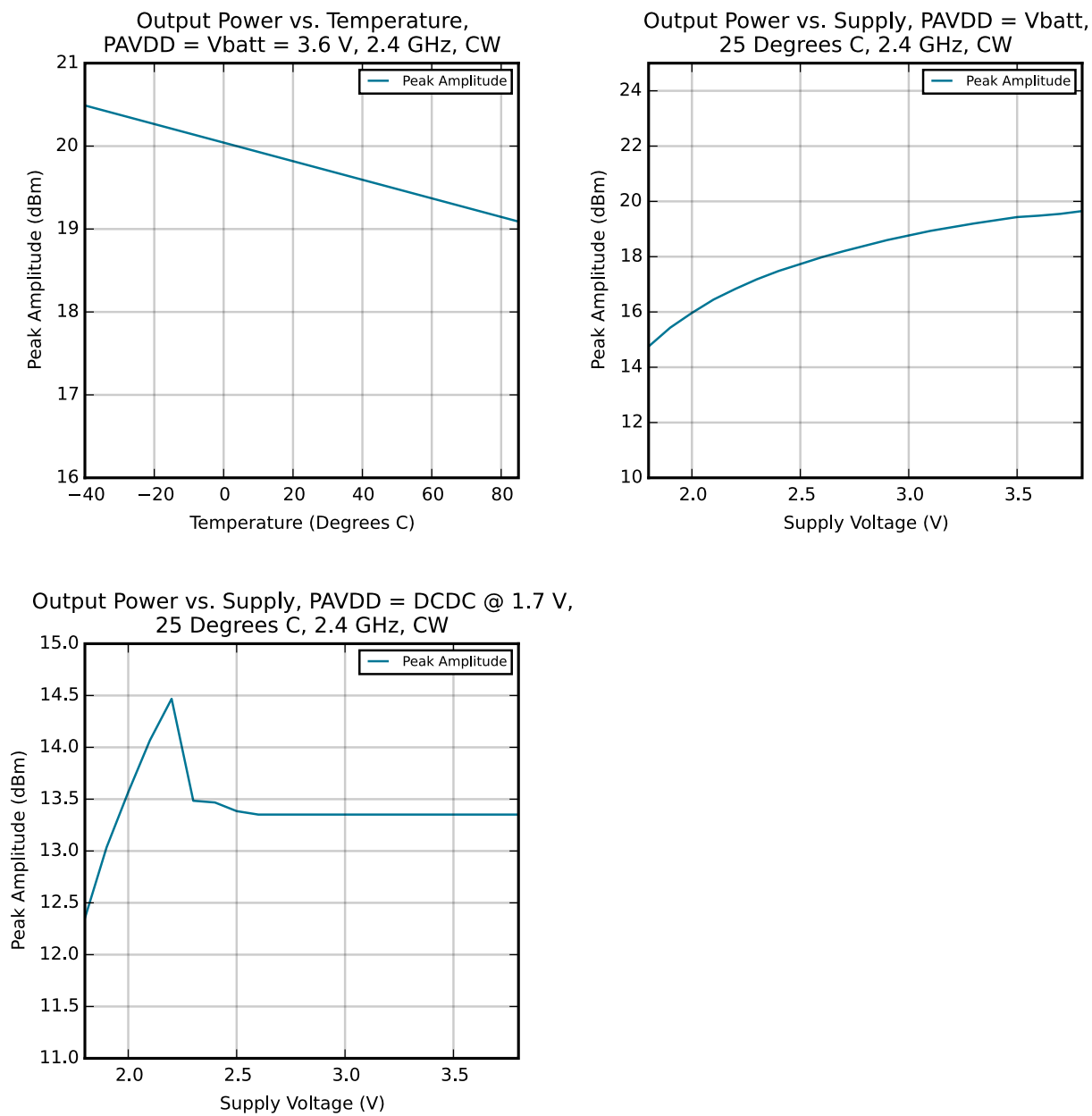


Figure 4.20. 2.4 GHz RF Transmitter Output Power

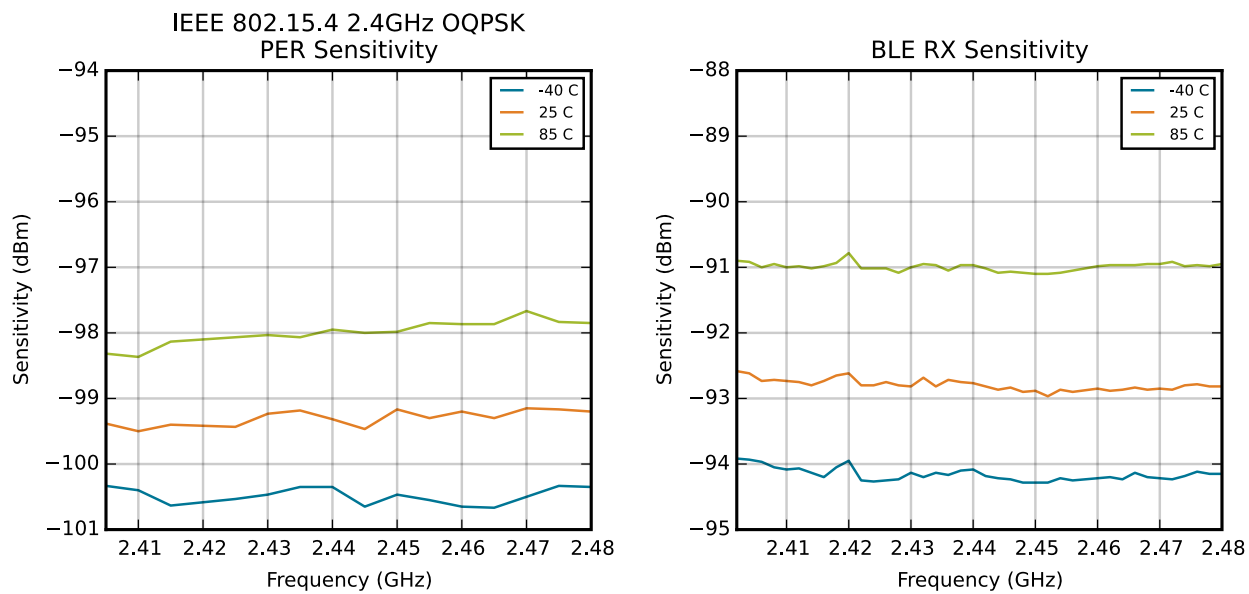
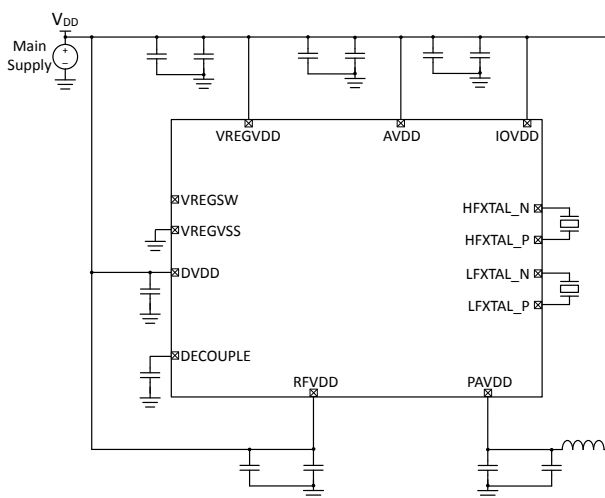


Figure 4.21. 2.4 GHz RF Receiver Sensitivity

## 5. Typical Connection Diagrams

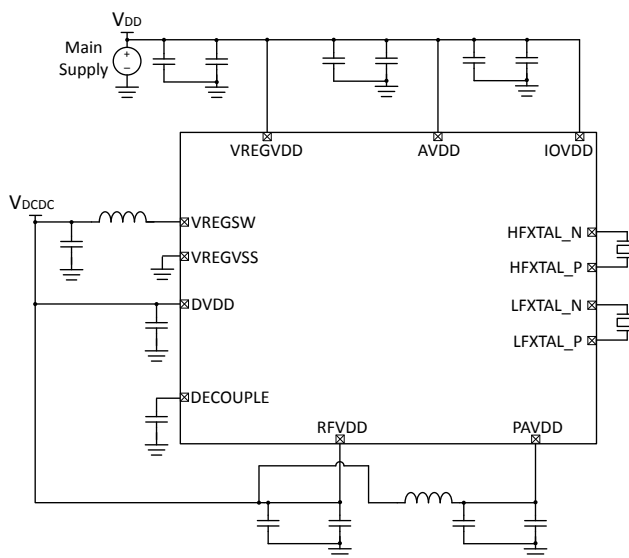
### 5.1 Power

Typical power supply connections for direct supply, without using the internal DC-DC converter, are shown in the following figure.

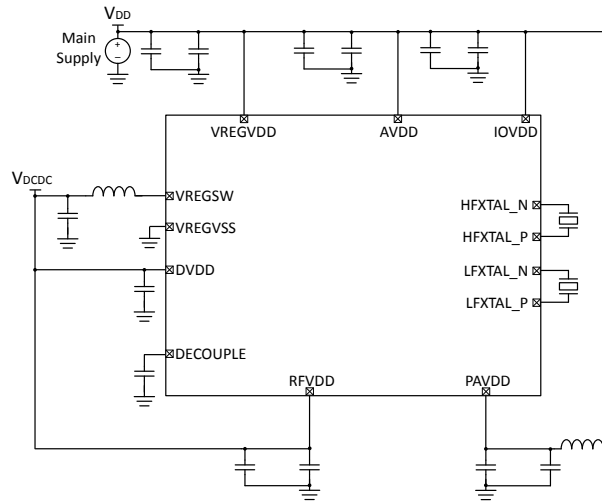


**Figure 5.1. EFR32FG1 Typical Application Circuit: Direct Supply Configuration without DC-DC converter**

Typical power supply circuits using the internal DC-DC converter are shown below. The MCU operates from the DC-DC converter supply. For low RF transmit power applications less than 13dBm, the RF PA may be supplied by the DC-DC converter. For OPNs supporting high power RF transmission, the RF PA must be directly supplied by VDD for RF transmit power greater than 13 dBm.



**Figure 5.2. EFR32FG1 Typical Application Circuit: Configuration with DC-DC converter (PAVDD from VDCDC)**

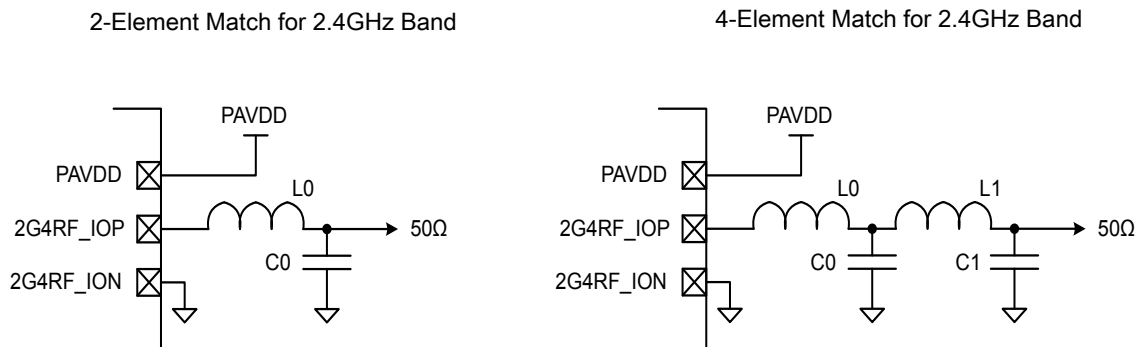


**Figure 5.3. EFR32FG1 Typical Application Circuit: Configuration with DC-DC converter (PAVDD from VDD)**

## 5.2 RF Matching Networks

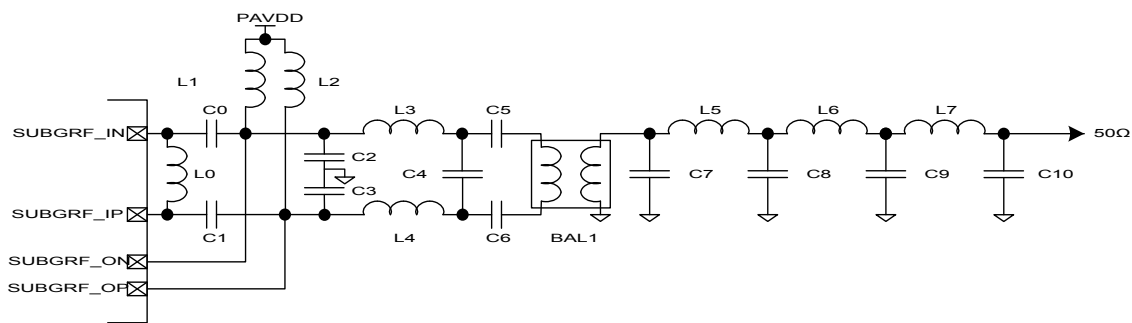
Typical RF matching network circuit diagrams are shown in [Figure 5.4 Typical 2.4 GHz RF impedance-matching network circuits on page 94](#) for applications in the 2.4GHz band, and in [Figure 5.5 Typical Sub-GHz RF impedance-matching network circuits on page 95](#) for applications in the sub-GHz band. Application-specific component values can be found in the EFR32 Reference Manual. For low RF transmit power applications less than 13dBm, the two-element match is recommended. For OPNs supporting high power RF transmission, the four-element match is recommended for high RF transmit power (> 13dBm).

Typical RF matching network circuit diagrams are shown in [Figure 5.5 Typical Sub-GHz RF impedance-matching network circuits on page 95](#) for applications in the sub-GHz band. Application-specific component values can be found in the EFR32 Reference Manual. For low RF transmit power applications less than 13dBm, the two-element match is recommended. For OPNs supporting high power RF transmission, the four-element match is recommended for high RF transmit power (> 13dBm).



**Figure 5.4. Typical 2.4 GHz RF impedance-matching network circuits**

Sub-GHz Match Topology I (169-450 MHz)



Sub-GHz Match Topology 2 (450-915 MHz)

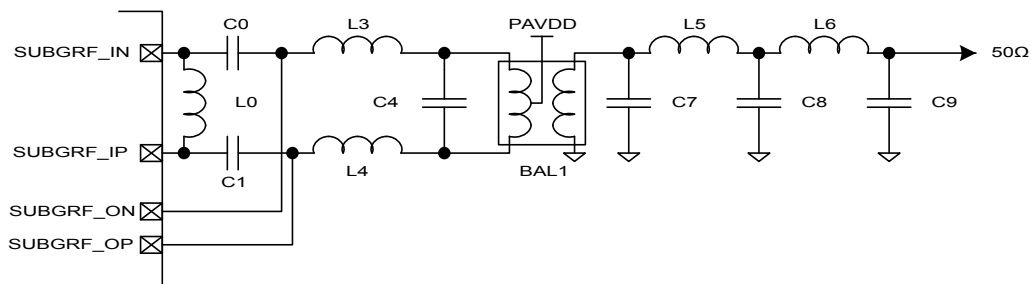


Figure 5.5. Typical Sub-GHz RF impedance-matching network circuits

### 5.3 Other Connections

Other components or connections may be required to meet the system-level requirements. Application Note AN0002: "Hardware Design Considerations" contains detailed information on these connections. Application Notes can be accessed on the Silicon Labs website ([www.silabs.com/32bit-appnotes](http://www.silabs.com/32bit-appnotes)).



## 6. Pin Definitions

### 6.1 EFR32FG1 QFN48 Sub-GHz Definition

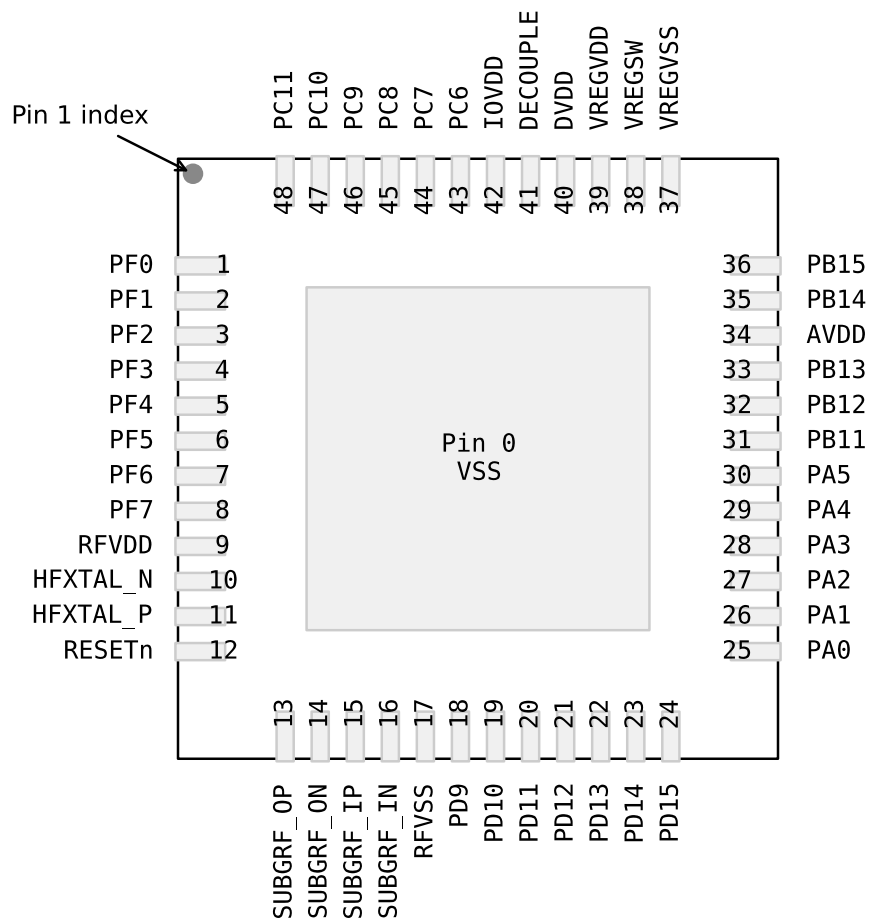


Figure 6.1. EFR32FG1 QFN48 Sub-GHz Pinout

Table 6.1. QFN48 Sub-GHz Device Pinout

| QFN48 Pin# and Name |          | Pin Alternate Functionality / Description  |  |  |   |  |
|---------------------|----------|--|--|--|---|--|
| Pin #               | Pin Name | Analog   | Timers   | Communication  | Radio   | Other  |
| 0                   | VSS      | Ground   |  |  |   |  |
| 1                   | PF0      | BUSAX [ADC0:<br>APORT1XCH16<br>ACMP0:<br>APORT1XCH16<br>ACMP1:<br>APORT1XCH16]<br><br>BUSBY [ADC0:<br>APORT2YCH16<br>ACMP0:<br>APORT2YCH16<br>ACMP1:<br>APORT2YCH16] | TIM0_CC0 #24<br>TIM0_CC1 #23<br>TIM0_CC2 #22<br>TIM0_CDTI0 #21<br>TIM0_CDTI1 #20<br>TIM0_CDTI2 #19<br>TIM1_CC0 #24<br>TIM1_CC1 #23<br>TIM1_CC2 #22<br>TIM1_CC3 #21 LE-<br>TIM0_OUT0 #24<br>LETIM0_OUT1 #23<br>PCNT0_S0IN #24<br>PCNT0_S1IN #23 | US0_TX #24<br>US0_RX #23<br>US0_CLK #22<br>US0_CS #21<br>US0_CTS #20<br>US0_RTS #19<br>US1_TX #24<br>US1_RX #23<br>US1_CLK #22<br>US1_CS #21<br>US1_CTS #20<br>US1_RTS #19<br>LEU0_TX #24<br>LEU0_RX #23<br>I2C0_SDA #24<br>I2C0_SCL #23 | FRC_DCLK #24<br>FRC_DOUT #23<br>FRC_DFRAME #22<br>MODEM_DCLK #24<br>MODEM_DIN #23<br>MODEM_DOUT #22<br>MODEM_ANT0 #21<br>MODEM_ANT1 #20 | PRS_CH0 #0<br>PRS_CH1 #7<br>PRS_CH2 #6<br>PRS_CH3 #5<br>ACMP0_O #24<br>ACMP1_O #24<br>DBG_SWCLKTCK #0  |
| 2                   | PF1      | BUSAY [ADC0:<br>APORT1YCH17<br>ACMP0:<br>APORT1YCH17<br>ACMP1:<br>APORT1YCH17]<br><br>BUSBX [ADC0:<br>APORT2XCH17<br>ACMP0:<br>APORT2XCH17<br>ACMP1:<br>APORT2XCH17] | TIM0_CC0 #25<br>TIM0_CC1 #24<br>TIM0_CC2 #23<br>TIM0_CDTI0 #22<br>TIM0_CDTI1 #21<br>TIM0_CDTI2 #20<br>TIM1_CC0 #25<br>TIM1_CC1 #24<br>TIM1_CC2 #23<br>TIM1_CC3 #22 LE-<br>TIM0_OUT0 #25<br>LETIM0_OUT1 #24<br>PCNT0_S0IN #25<br>PCNT0_S1IN #24 | US0_TX #25<br>US0_RX #24<br>US0_CLK #23<br>US0_CS #22<br>US0_CTS #21<br>US0_RTS #20<br>US1_TX #25<br>US1_RX #24<br>US1_CLK #23<br>US1_CS #22<br>US1_CTS #21<br>US1_RTS #20<br>LEU0_TX #25<br>LEU0_RX #24<br>I2C0_SDA #25<br>I2C0_SCL #24 | FRC_DCLK #25<br>FRC_DOUT #24<br>FRC_DFRAME #23<br>MODEM_DCLK #25<br>MODEM_DIN #24<br>MODEM_DOUT #23<br>MODEM_ANT0 #22<br>MODEM_ANT1 #21 | PRS_CH0 #1<br>PRS_CH1 #0<br>PRS_CH2 #7<br>PRS_CH3 #6<br>ACMP0_O #25<br>ACMP1_O #25<br>DBG_SWDIOTMS #0  |
| 3                   | PF2      | BUSAX [ADC0:<br>APORT1XCH18<br>ACMP0:<br>APORT1XCH18<br>ACMP1:<br>APORT1XCH18]<br><br>BUSBY [ADC0:<br>APORT2YCH18<br>ACMP0:<br>APORT2YCH18<br>ACMP1:<br>APORT2YCH18] | TIM0_CC0 #26<br>TIM0_CC1 #25<br>TIM0_CC2 #24<br>TIM0_CDTI0 #23<br>TIM0_CDTI1 #22<br>TIM0_CDTI2 #21<br>TIM1_CC0 #26<br>TIM1_CC1 #25<br>TIM1_CC2 #24<br>TIM1_CC3 #23 LE-<br>TIM0_OUT0 #26<br>LETIM0_OUT1 #25<br>PCNT0_S0IN #26<br>PCNT0_S1IN #25 | US0_TX #26<br>US0_RX #25<br>US0_CLK #24<br>US0_CS #23<br>US0_CTS #22<br>US0_RTS #21<br>US1_TX #26<br>US1_RX #25<br>US1_CLK #24<br>US1_CS #23<br>US1_CTS #22<br>US1_RTS #21<br>LEU0_TX #26<br>LEU0_RX #25<br>I2C0_SDA #26<br>I2C0_SCL #25 | FRC_DCLK #26<br>FRC_DOUT #25<br>FRC_DFRAME #24<br>MODEM_DCLK #26<br>MODEM_DIN #25<br>MODEM_DOUT #24<br>MODEM_ANT0 #23<br>MODEM_ANT1 #22 | CMU_CLK0 #6<br>PRS_CH0 #2<br>PRS_CH1 #1<br>PRS_CH2 #0<br>PRS_CH3 #7<br>ACMP0_O #26<br>ACMP1_O #26<br>DBG_TDO #0<br>DBG_SWO #0<br>GPIO_EM4WU0 |

| QFN48 Pin# and Name |          | Pin Alternate Functionality / Description  |  |  |   |   |
|---------------------|----------|--|--|--|---|---|
| Pin #               | Pin Name | Analog   | Timers   | Communication  | Radio   | Other   |
| 4                   | PF3      | BUSAY [ADC0:<br>APORT1YCH19<br>ACMP0:<br>APORT1YCH19<br>ACMP1:<br>APORT1YCH19]<br><br>BUSBX [ADC0:<br>APORT2XCH19<br>ACMP0:<br>APORT2XCH19<br>ACMP1:<br>APORT2XCH19] | TIM0_CC0 #27<br>TIM0_CC1 #26<br>TIM0_CC2 #25<br>TIM0_CDTI0 #24<br>TIM0_CDTI1 #23<br>TIM0_CDTI2 #22<br>TIM1_CC0 #27<br>TIM1_CC1 #26<br>TIM1_CC2 #25<br>TIM1_CC3 #24 LE-<br>TIM0_OUT0 #27<br>LETIM0_OUT1 #26<br>PCNT0_S0IN #27<br>PCNT0_S1IN #26 | US0_TX #27<br>US0_RX #26<br>US0_CLK #25<br>US0_CS #24<br>US0_CTS #23<br>US0_RTS #22<br>US1_TX #27<br>US1_RX #26<br>US1_CLK #25<br>US1_CS #24<br>US1_CTS #23<br>US1_RTS #22<br>LEU0_TX #27<br>LEU0_RX #26<br>I2C0_SDA #27<br>I2C0_SCL #26 | FRC_DCLK #27<br>FRC_DOUT #26<br>FRC_DFRAME #25<br>MODEM_DCLK #27<br>MODEM_DIN #26<br>MODEM_DOUT #25<br>MODEM_ANT0 #24<br>MODEM_ANT1 #23 | CMU_CLK1 #6<br>PRS_CH0 #3<br>PRS_CH1 #2<br>PRS_CH2 #1<br>PRS_CH3 #0<br>ACMP0_O #27<br>ACMP1_O #27<br>DBG_TDI #0 |
| 5                   | PF4      | BUSAX [ADC0:<br>APORT1XCH20<br>ACMP0:<br>APORT1XCH20<br>ACMP1:<br>APORT1XCH20]<br><br>BUSBY [ADC0:<br>APORT2YCH20<br>ACMP0:<br>APORT2YCH20<br>ACMP1:<br>APORT2YCH20] | TIM0_CC0 #28<br>TIM0_CC1 #27<br>TIM0_CC2 #26<br>TIM0_CDTI0 #25<br>TIM0_CDTI1 #24<br>TIM0_CDTI2 #23<br>TIM1_CC0 #28<br>TIM1_CC1 #27<br>TIM1_CC2 #26<br>TIM1_CC3 #25 LE-<br>TIM0_OUT0 #28<br>LETIM0_OUT1 #27<br>PCNT0_S0IN #28<br>PCNT0_S1IN #27 | US0_TX #28<br>US0_RX #27<br>US0_CLK #26<br>US0_CS #25<br>US0_CTS #24<br>US0_RTS #23<br>US1_TX #28<br>US1_RX #27<br>US1_CLK #26<br>US1_CS #25<br>US1_CTS #24<br>US1_RTS #23<br>LEU0_TX #28<br>LEU0_RX #27<br>I2C0_SDA #28<br>I2C0_SCL #27 | FRC_DCLK #28<br>FRC_DOUT #27<br>FRC_DFRAME #26<br>MODEM_DCLK #28<br>MODEM_DIN #27<br>MODEM_DOUT #26<br>MODEM_ANT0 #25<br>MODEM_ANT1 #24 | PRS_CH0 #4<br>PRS_CH1 #3<br>PRS_CH2 #2<br>PRS_CH3 #1<br>ACMP0_O #28<br>ACMP1_O #28                              |
| 6                   | PF5      | BUSAY [ADC0:<br>APORT1YCH21<br>ACMP0:<br>APORT1YCH21<br>ACMP1:<br>APORT1YCH21]<br><br>BUSBX [ADC0:<br>APORT2XCH21<br>ACMP0:<br>APORT2XCH21<br>ACMP1:<br>APORT2XCH21] | TIM0_CC0 #29<br>TIM0_CC1 #28<br>TIM0_CC2 #27<br>TIM0_CDTI0 #26<br>TIM0_CDTI1 #25<br>TIM0_CDTI2 #24<br>TIM1_CC0 #29<br>TIM1_CC1 #28<br>TIM1_CC2 #27<br>TIM1_CC3 #26 LE-<br>TIM0_OUT0 #29<br>LETIM0_OUT1 #28<br>PCNT0_S0IN #29<br>PCNT0_S1IN #28 | US0_TX #29<br>US0_RX #28<br>US0_CLK #27<br>US0_CS #26<br>US0_CTS #25<br>US0_RTS #24<br>US1_TX #29<br>US1_RX #28<br>US1_CLK #27<br>US1_CS #26<br>US1_CTS #25<br>US1_RTS #24<br>LEU0_TX #29<br>LEU0_RX #28<br>I2C0_SDA #29<br>I2C0_SCL #28 | FRC_DCLK #29<br>FRC_DOUT #28<br>FRC_DFRAME #27<br>MODEM_DCLK #29<br>MODEM_DIN #28<br>MODEM_DOUT #27<br>MODEM_ANT0 #26<br>MODEM_ANT1 #25 | PRS_CH0 #5<br>PRS_CH1 #4<br>PRS_CH2 #3<br>PRS_CH3 #2<br>ACMP0_O #29<br>ACMP1_O #29                              |

| QFN48 Pin# and Name |           | Pin Alternate Functionality / Description   |  |  |   |  |
|---------------------|-----------|---|--|--|---|--|
| Pin #               | Pin Name  | Analog  | Timers   | Communication  | Radio   | Other  |
| 7                   | PF6       | BUSAX [ADC0: APORT1XCH22 ACMP0: APORT1XCH22 ACMP1: APORT1XCH22]<br><br>BUSBY [ADC0: APORT2YCH22 ACMP0: APORT2YCH22 ACMP1: APORT2YCH22]  | TIM0_CC0 #30<br>TIM0_CC1 #29<br>TIM0_CC2 #28<br>TIM0_CDTI0 #27<br>TIM0_CDTI1 #26<br>TIM0_CDTI2 #25<br>TIM1_CC0 #30<br>TIM1_CC1 #29<br>TIM1_CC2 #28<br>TIM1_CC3 #27 LE-<br>TIM0_OUT0 #30<br>LETIM0_OUT1 #29<br>PCNT0_S0IN #30<br>PCNT0_S1IN #29 | US0_TX #30<br>US0_RX #29<br>US0_CLK #28<br>US0_CS #27<br>US0_CTS #26<br>US0_RTS #25<br>US1_TX #30<br>US1_RX #29<br>US1_CLK #28<br>US1_CS #27<br>US1_CTS #26<br>US1_RTS #25<br>LEU0_TX #30<br>LEU0_RX #29<br>I2C0_SDA #30<br>I2C0_SCL #29 | FRC_DCLK #30<br>FRC_DOUT #29<br>FRC_DFRAME #28<br>MODEM_DCLK #30<br>MODEM_DIN #29<br>MODEM_DOUT #28<br>MODEM_ANT0 #27<br>MODEM_ANT1 #26 | CMU_CLK1 #7<br>PRS_CH0 #6<br>PRS_CH1 #5<br>PRS_CH2 #4<br>PRS_CH3 #3<br>ACMP0_O #30<br>ACMP1_O #30                |
| 8                   | PF7       | BUSAY [ADC0: APORT1YCH23 ACMP0: APORT1YCH23 ACMP1: APORT1YCH23]<br><br>BUSBX [ADC0: APORT2XCH23 ACMP0: APORT2XCH23 ACMP1: APORT2XCH23]  | TIM0_CC0 #31<br>TIM0_CC1 #30<br>TIM0_CC2 #29<br>TIM0_CDTI0 #28<br>TIM0_CDTI1 #27<br>TIM0_CDTI2 #26<br>TIM1_CC0 #31<br>TIM1_CC1 #30<br>TIM1_CC2 #29<br>TIM1_CC3 #28 LE-<br>TIM0_OUT0 #31<br>LETIM0_OUT1 #30<br>PCNT0_S0IN #31<br>PCNT0_S1IN #30 | US0_TX #31<br>US0_RX #30<br>US0_CLK #29<br>US0_CS #28<br>US0_CTS #27<br>US0_RTS #26<br>US1_TX #31<br>US1_RX #30<br>US1_CLK #29<br>US1_CS #28<br>US1_CTS #27<br>US1_RTS #26<br>LEU0_TX #31<br>LEU0_RX #30<br>I2C0_SDA #31<br>I2C0_SCL #30 | FRC_DCLK #31<br>FRC_DOUT #30<br>FRC_DFRAME #29<br>MODEM_DCLK #31<br>MODEM_DIN #30<br>MODEM_DOUT #29<br>MODEM_ANT0 #28<br>MODEM_ANT1 #27 | CMU_CLK0 #7<br>PRS_CH0 #7<br>PRS_CH1 #6<br>PRS_CH2 #5<br>PRS_CH3 #4<br>ACMP0_O #31<br>ACMP1_O #31<br>GPIO_EM4WU1 |
| 9                   | RFVDD     | Radio power supply  |  |  |   |  |
| 10                  | HFXTAL_N  | High Frequency Crystal input pin.   |  |  |   |  |
| 11                  | HFXTAL_P  | High Frequency Crystal output pin.  |  |  |   |  |
| 12                  | RESETn    | Reset input, active low. To apply an external reset source to this pin, it is required to only drive this pin low during reset, and let the internal pull-up ensure that reset is released. |  |  |   |  |
| 13                  | SUBGRF_OP | Sub GHz Differential RF output, positive path.  |  |  |   |  |
| 14                  | SUBGRF_ON | Sub GHz Differential RF output, negative path.  |  |  |   |  |
| 15                  | SUBGRF_IP | Sub GHz Differential RF input, positive path.   |  |  |   |  |
| 16                  | SUBGRF_IN | Sub GHz Differential RF input, negative path.   |  |  |   |  |
| 17                  | RFVSS     | Radio Ground  |  |  |   |  |

| QFN48 Pin# and Name |          | Pin Alternate Functionality / Description  |  |  |   |  |
|---------------------|----------|--|--|--|---|--|
| Pin #               | Pin Name | Analog   | Timers   | Communication  | Radio   | Other  |
| 18                  | PD9      | BUSCY [ADC0:<br>APORT3YCH1<br>ACMP0:<br>APORT3YCH1<br>ACMP1:<br>APORT3YCH1<br>IDAC0:<br>APORT1YCH1]<br><br>BUSDX [ADC0:<br>APORT4XCH1<br>ACMP0:<br>APORT4XCH1<br>ACMP1:<br>APORT4XCH1] | TIM0_CC0 #17<br>TIM0_CC1 #16<br>TIM0_CC2 #15<br>TIM0_CDTI0 #14<br>TIM0_CDTI1 #13<br>TIM0_CDTI2 #12<br>TIM1_CC0 #17<br>TIM1_CC1 #16<br>TIM1_CC2 #15<br>TIM1_CC3 #14 LE-<br>TIM0_OUT0 #17<br>LETIM0_OUT1 #16<br>PCNT0_S0IN #17<br>PCNT0_S1IN #16 | US0_TX #17<br>US0_RX #16<br>US0_CLK #15<br>US0_CS #14<br>US0_CTS #13<br>US0_RTS #12<br>US1_TX #17<br>US1_RX #16<br>US1_CLK #15<br>US1_CS #14<br>US1_CTS #13<br>US1_RTS #12<br>LEU0_TX #17<br>LEU0_RX #16<br>I2C0_SDA #17<br>I2C0_SCL #16 | FRC_DCLK #17<br>FRC_DOUT #16<br>FRC_DFRAME #15<br>MODEM_DCLK #17<br>MODEM_DIN #16<br>MODEM_DOUT #15<br>MODEM_ANT0 #14<br>MODEM_ANT1 #13 | CMU_CLK0 #4<br>PRS_CH3 #8<br>PRS_CH4 #0<br>PRS_CH5 #6<br>PRS_CH6 #11<br>ACMP0_O #17<br>ACMP1_O #17 |
| 19                  | PD10     | BUSCX [ADC0:<br>APORT3XCH2<br>ACMP0:<br>APORT3XCH2<br>ACMP1:<br>APORT3XCH2<br>IDAC0:<br>APORT1XCH2]<br><br>BUSDY [ADC0:<br>APORT4YCH2<br>ACMP0:<br>APORT4YCH2<br>ACMP1:<br>APORT4YCH2] | TIM0_CC0 #18<br>TIM0_CC1 #17<br>TIM0_CC2 #16<br>TIM0_CDTI0 #15<br>TIM0_CDTI1 #14<br>TIM0_CDTI2 #13<br>TIM1_CC0 #18<br>TIM1_CC1 #17<br>TIM1_CC2 #16<br>TIM1_CC3 #15 LE-<br>TIM0_OUT0 #18<br>LETIM0_OUT1 #17<br>PCNT0_S0IN #18<br>PCNT0_S1IN #17 | US0_TX #18<br>US0_RX #17<br>US0_CLK #16<br>US0_CS #15<br>US0_CTS #14<br>US0_RTS #13<br>US1_TX #18<br>US1_RX #17<br>US1_CLK #16<br>US1_CS #15<br>US1_CTS #14<br>US1_RTS #13<br>LEU0_TX #18<br>LEU0_RX #17<br>I2C0_SDA #18<br>I2C0_SCL #17 | FRC_DCLK #18<br>FRC_DOUT #17<br>FRC_DFRAME #16<br>MODEM_DCLK #18<br>MODEM_DIN #17<br>MODEM_DOUT #16<br>MODEM_ANT0 #15<br>MODEM_ANT1 #14 | CMU_CLK1 #4<br>PRS_CH3 #9<br>PRS_CH4 #1<br>PRS_CH5 #0<br>PRS_CH6 #12<br>ACMP0_O #18<br>ACMP1_O #18 |
| 20                  | PD11     | BUSCY [ADC0:<br>APORT3YCH3<br>ACMP0:<br>APORT3YCH3<br>ACMP1:<br>APORT3YCH3<br>IDAC0:<br>APORT1YCH3]<br><br>BUSDX [ADC0:<br>APORT4XCH3<br>ACMP0:<br>APORT4XCH3<br>ACMP1:<br>APORT4XCH3] | TIM0_CC0 #19<br>TIM0_CC1 #18<br>TIM0_CC2 #17<br>TIM0_CDTI0 #16<br>TIM0_CDTI1 #15<br>TIM0_CDTI2 #14<br>TIM1_CC0 #19<br>TIM1_CC1 #18<br>TIM1_CC2 #17<br>TIM1_CC3 #16 LE-<br>TIM0_OUT0 #19<br>LETIM0_OUT1 #18<br>PCNT0_S0IN #19<br>PCNT0_S1IN #18 | US0_TX #19<br>US0_RX #18<br>US0_CLK #17<br>US0_CS #16<br>US0_CTS #15<br>US0_RTS #14<br>US1_TX #19<br>US1_RX #18<br>US1_CLK #17<br>US1_CS #16<br>US1_CTS #15<br>US1_RTS #14<br>LEU0_TX #19<br>LEU0_RX #18<br>I2C0_SDA #19<br>I2C0_SCL #18 | FRC_DCLK #19<br>FRC_DOUT #18<br>FRC_DFRAME #17<br>MODEM_DCLK #19<br>MODEM_DIN #18<br>MODEM_DOUT #17<br>MODEM_ANT0 #16<br>MODEM_ANT1 #15 | PRS_CH3 #10<br>PRS_CH4 #2<br>PRS_CH5 #1<br>PRS_CH6 #13<br>ACMP0_O #19<br>ACMP1_O #19               |

| QFN48 Pin# and Name |          | Pin Alternate Functionality / Description  |  |  |   |  |
|---------------------|----------|--|--|--|---|--|
| Pin #               | Pin Name | Analog   | Timers   | Communication  | Radio   | Other  |
| 21                  | PD12     | BUSCX [ADC0:<br>APORT3XCH4<br>ACMP0:<br>APORT3XCH4<br>ACMP1:<br>APORT3XCH4<br>IDAC0:<br>APORT1XCH4]<br><br>BUSDY [ADC0:<br>APORT4YCH4<br>ACMP0:<br>APORT4YCH4<br>ACMP1:<br>APORT4YCH4] | TIM0_CC0 #20<br>TIM0_CC1 #19<br>TIM0_CC2 #18<br>TIM0_CDTI0 #17<br>TIM0_CDTI1 #16<br>TIM0_CDTI2 #15<br>TIM1_CC0 #20<br>TIM1_CC1 #19<br>TIM1_CC2 #18<br>TIM1_CC3 #17 LE-<br>TIM0_OUT0 #20<br>LETIM0_OUT1 #19<br>PCNT0_S0IN #20<br>PCNT0_S1IN #19 | US0_TX #20<br>US0_RX #19<br>US0_CLK #18<br>US0_CS #17<br>US0_CTS #16<br>US0_RTS #15<br>US1_TX #20<br>US1_RX #19<br>US1_CLK #18<br>US1_CS #17<br>US1_CTS #16<br>US1_RTS #15<br>LEU0_TX #20<br>LEU0_RX #19<br>I2C0_SDA #20<br>I2C0_SCL #19 | FRC_DCLK #20<br>FRC_DOUT #19<br>FRC_DFRAME #18<br>MODEM_DCLK #20<br>MODEM_DIN #19<br>MODEM_DOUT #18<br>MODEM_ANT0 #17<br>MODEM_ANT1 #16 | PRS_CH3 #11<br>PRS_CH4 #3<br>PRS_CH5 #2<br>PRS_CH6 #14<br>ACMP0_O #20<br>ACMP1_O #20                               |
| 22                  | PD13     | BUSCY [ADC0:<br>APORT3YCH5<br>ACMP0:<br>APORT3YCH5<br>ACMP1:<br>APORT3YCH5<br>IDAC0:<br>APORT1YCH5]<br><br>BUSDX [ADC0:<br>APORT4XCH5<br>ACMP0:<br>APORT4XCH5<br>ACMP1:<br>APORT4XCH5] | TIM0_CC0 #21<br>TIM0_CC1 #20<br>TIM0_CC2 #19<br>TIM0_CDTI0 #18<br>TIM0_CDTI1 #17<br>TIM0_CDTI2 #16<br>TIM1_CC0 #21<br>TIM1_CC1 #20<br>TIM1_CC2 #19<br>TIM1_CC3 #18 LE-<br>TIM0_OUT0 #21<br>LETIM0_OUT1 #20<br>PCNT0_S0IN #21<br>PCNT0_S1IN #20 | US0_TX #21<br>US0_RX #20<br>US0_CLK #19<br>US0_CS #18<br>US0_CTS #17<br>US0_RTS #16<br>US1_TX #21<br>US1_RX #20<br>US1_CLK #19<br>US1_CS #18<br>US1_CTS #17<br>US1_RTS #16<br>LEU0_TX #21<br>LEU0_RX #20<br>I2C0_SDA #21<br>I2C0_SCL #20 | FRC_DCLK #21<br>FRC_DOUT #20<br>FRC_DFRAME #19<br>MODEM_DCLK #21<br>MODEM_DIN #20<br>MODEM_DOUT #19<br>MODEM_ANT0 #18<br>MODEM_ANT1 #17 | PRS_CH3 #12<br>PRS_CH4 #4<br>PRS_CH5 #3<br>PRS_CH6 #15<br>ACMP0_O #21<br>ACMP1_O #21                               |
| 23                  | PD14     | BUSCX [ADC0:<br>APORT3XCH6<br>ACMP0:<br>APORT3XCH6<br>ACMP1:<br>APORT3XCH6<br>IDAC0:<br>APORT1XCH6]<br><br>BUSDY [ADC0:<br>APORT4YCH6<br>ACMP0:<br>APORT4YCH6<br>ACMP1:<br>APORT4YCH6] | TIM0_CC0 #22<br>TIM0_CC1 #21<br>TIM0_CC2 #20<br>TIM0_CDTI0 #19<br>TIM0_CDTI1 #18<br>TIM0_CDTI2 #17<br>TIM1_CC0 #22<br>TIM1_CC1 #21<br>TIM1_CC2 #20<br>TIM1_CC3 #19 LE-<br>TIM0_OUT0 #22<br>LETIM0_OUT1 #21<br>PCNT0_S0IN #22<br>PCNT0_S1IN #21 | US0_TX #22<br>US0_RX #21<br>US0_CLK #20<br>US0_CS #19<br>US0_CTS #18<br>US0_RTS #17<br>US1_TX #22<br>US1_RX #21<br>US1_CLK #20<br>US1_CS #19<br>US1_CTS #18<br>US1_RTS #17<br>LEU0_TX #22<br>LEU0_RX #21<br>I2C0_SDA #22<br>I2C0_SCL #21 | FRC_DCLK #22<br>FRC_DOUT #21<br>FRC_DFRAME #20<br>MODEM_DCLK #22<br>MODEM_DIN #21<br>MODEM_DOUT #20<br>MODEM_ANT0 #19<br>MODEM_ANT1 #18 | CMU_CLK0 #5<br>PRS_CH3 #13<br>PRS_CH4 #5<br>PRS_CH5 #4<br>PRS_CH6 #16<br>ACMP0_O #22<br>ACMP1_O #22<br>GPIO_EM4WU4 |

| QFN48 Pin# and Name |          | Pin Alternate Functionality / Description   |  |  |   |   |
|---------------------|----------|---|--|--|---|---|
| Pin #               | Pin Name | Analog  | Timers   | Communication  | Radio   | Other   |
| 24                  | PD15     | BUSCY [ADC0:<br>APORT3YCH7<br>ACMP0:<br>APORT3YCH7<br>ACMP1:<br>APORT3YCH7<br>IDAC0:<br>APORT1YCH7]<br><br>BUSDX [ADC0:<br>APORT4XCH7<br>ACMP0:<br>APORT4XCH7<br>ACMP1:<br>APORT4XCH7]                  | TIM0_CC0 #23<br>TIM0_CC1 #22<br>TIM0_CC2 #21<br>TIM0_CDTI0 #20<br>TIM0_CDTI1 #19<br>TIM0_CDTI2 #18<br>TIM1_CC0 #23<br>TIM1_CC1 #22<br>TIM1_CC2 #21<br>TIM1_CC3 #20 LE-<br>TIM0_OUT0 #23<br>LETIM0_OUT1 #22<br>PCNT0_S0IN #23<br>PCNT0_S1IN #22 | US0_TX #23<br>US0_RX #22<br>US0_CLK #21<br>US0_CS #20<br>US0_CTS #19<br>US0_RTS #18<br>US1_TX #23<br>US1_RX #22<br>US1_CLK #21<br>US1_CS #20<br>US1_CTS #19<br>US1_RTS #18<br>LEU0_TX #23<br>LEU0_RX #22<br>I2C0_SDA #23<br>I2C0_SCL #22 | FRC_DCLK #23<br>FRC_DOUT #22<br>FRC_DFRAME #21<br>MODEM_DCLK #23<br>MODEM_DIN #22<br>MODEM_DOUT #21<br>MODEM_ANT0 #20<br>MODEM_ANT1 #19 | CMU_CLK1 #5<br>PRS_CH3 #14<br>PRS_CH4 #6<br>PRS_CH5 #5<br>PRS_CH6 #17<br>ACMP0_O #23<br>ACMP1_O #23<br>DBG_SWO #2 |
| 25                  | PA0      | ADC0_EXTN<br><br>BUSCX [ADC0:<br>APORT3XCH8<br>ACMP0:<br>APORT3XCH8<br>ACMP1:<br>APORT3XCH8<br>IDAC0:<br>APORT1XCH8]<br><br>BUSDY [ADC0:<br>APORT4YCH8<br>ACMP0:<br>APORT4YCH8<br>ACMP1:<br>APORT4YCH8] | TIM0_CC0 #0<br>TIM0_CC1 #31<br>TIM0_CC2 #30<br>TIM0_CDTI0 #29<br>TIM0_CDTI1 #28<br>TIM0_CDTI2 #27<br>TIM1_CC0 #0<br>TIM1_CC1 #31<br>TIM1_CC2 #30<br>TIM1_CC3 #29 LE-<br>TIM0_OUT0 #0 LE-<br>TIM0_OUT1 #31<br>PCNT0_S0IN #0<br>PCNT0_S1IN #31   | US0_TX #0<br>US0_RX #31<br>US0_CLK #30<br>US0_CS #29<br>US0_CTS #28<br>US0_RTS #27<br>US1_TX #0<br>US1_RX #31<br>US1_CLK #30<br>US1_CS #29<br>US1_CTS #28<br>US1_RTS #27<br>LEU0_TX #0<br>LEU0_RX #31<br>I2C0_SDA #0<br>I2C0_SCL #31     | FRC_DCLK #0<br>FRC_DOUT #31<br>FRC_DFRAME #30<br>MODEM_DCLK #0<br>MODEM_DIN #31<br>MODEM_DOUT #30<br>MODEM_ANT0 #29<br>MODEM_ANT1 #28   | CMU_CLK1 #0<br>PRS_CH6 #0<br>PRS_CH7 #10<br>PRS_CH8 #9<br>PRS_CH9 #8<br>ACMP0_O #0<br>ACMP1_O #0                  |
| 26                  | PA1      | ADC0_EXTP<br><br>BUSCY [ADC0:<br>APORT3YCH9<br>ACMP0:<br>APORT3YCH9<br>ACMP1:<br>APORT3YCH9<br>IDAC0:<br>APORT1YCH9]<br><br>BUSDX [ADC0:<br>APORT4XCH9<br>ACMP0:<br>APORT4XCH9<br>ACMP1:<br>APORT4XCH9] | TIM0_CC0 #1<br>TIM0_CC1 #0<br>TIM0_CC2 #31<br>TIM0_CDTI0 #30<br>TIM0_CDTI1 #29<br>TIM0_CDTI2 #28<br>TIM1_CC0 #1<br>TIM1_CC1 #0<br>TIM1_CC2 #31<br>TIM1_CC3 #30 LE-<br>TIM0_OUT0 #1 LE-<br>TIM0_OUT1 #0<br>PCNT0_S0IN #1<br>PCNT0_S1IN #0       | US0_TX #1<br>US0_RX #0<br>US0_CLK #31<br>US0_CS #30<br>US0_CTS #29<br>US0_RTS #28<br>US1_TX #1<br>US1_RX #0<br>US1_CLK #31<br>US1_CS #30<br>US1_CTS #29<br>US1_RTS #28<br>LEU0_TX #1<br>LEU0_RX #0<br>I2C0_SDA #1<br>I2C0_SCL #0         | FRC_DCLK #1<br>FRC_DOUT #0<br>FRC_DFRAME #31<br>MODEM_DCLK #1<br>MODEM_DIN #0<br>MODEM_DOUT #31<br>MODEM_ANT0 #30<br>MODEM_ANT1 #29     | CMU_CLK0 #0<br>PRS_CH6 #1<br>PRS_CH7 #0<br>PRS_CH8 #10<br>PRS_CH9 #9<br>ACMP0_O #1<br>ACMP1_O #1                  |

| QFN48 Pin# and Name |          | Pin Alternate Functionality / Description   |  |  |   |   |
|---------------------|----------|---|--|--|---|---|
| Pin #               | Pin Name | Analog  | Timers   | Communication  | Radio   | Other   |
| 27                  | PA2      | BUSCX [ADC0:<br>APORT3XCH10<br>ACMP0:<br>APORT3XCH10<br>ACMP1:<br>APORT3XCH10<br>IDAC0:<br>APORT1XCH10]<br><br>BUSDY [ADC0:<br>APORT4YCH10<br>ACMP0:<br>APORT4YCH10<br>ACMP1:<br>APORT4YCH10] | TIM0_CC0 #2<br>TIM0_CC1 #1<br>TIM0_CC2 #0<br>TIM0_CDTI0 #31<br>TIM0_CDTI1 #30<br>TIM0_CDTI2 #29<br>TIM1_CC0 #2<br>TIM1_CC1 #1<br>TIM1_CC2 #0<br>TIM1_CC3 #31 LE-<br>TIM0_OUT0 #2 LE-<br>TIM0_OUT1 #1<br>PCNT0_S0IN #2<br>PCNT0_S1IN #1 | US0_TX #2<br>US0_RX #1<br>US0_CLK #0<br>US0_CS #31<br>US0_CTS #30<br>US0_RTS #29<br>US1_TX #2<br>US1_RX #1<br>US1_CLK #0<br>US1_CS #31<br>US1_CTS #30<br>US1_RTS #29<br>LEU0_TX #2<br>LEU0_RX #1<br>I2C0_SDA #2<br>I2C0_SCL #1 | FRC_DCLK #2<br>FRC_DOUT #1<br>FRC_DFRAME #0<br>MODEM_DCLK #2<br>MODEM_DIN #1<br>MODEM_DOUT #0<br>MODEM_ANT0 #31<br>MODEM_ANT1 #30 | PRS_CH6 #2<br>PRS_CH7 #1<br>PRS_CH8 #0<br>PRS_CH9 #10<br>ACMP0_O #2<br>ACMP1_O #2               |
| 28                  | PA3      | BUSCY [ADC0:<br>APORT3YCH11<br>ACMP0:<br>APORT3YCH11<br>ACMP1:<br>APORT3YCH11<br>IDAC0:<br>APORT1YCH11]<br><br>BUSDX [ADC0:<br>APORT4XCH11<br>ACMP0:<br>APORT4XCH11<br>ACMP1:<br>APORT4XCH11] | TIM0_CC0 #3<br>TIM0_CC1 #2<br>TIM0_CC2 #1<br>TIM0_CDTI0 #0<br>TIM0_CDTI1 #31<br>TIM0_CDTI2 #30<br>TIM1_CC0 #3<br>TIM1_CC1 #2<br>TIM1_CC2 #1<br>TIM1_CC3 #0 LE-<br>TIM0_OUT0 #3 LE-<br>TIM0_OUT1 #2<br>PCNT0_S0IN #3<br>PCNT0_S1IN #2   | US0_TX #3<br>US0_RX #2<br>US0_CLK #1<br>US0_CS #0<br>US0_CTS #31<br>US0_RTS #30<br>US1_TX #3<br>US1_RX #2<br>US1_CLK #1<br>US1_CS #0<br>US1_CTS #31<br>US1_RTS #30<br>LEU0_TX #3<br>LEU0_RX #2<br>I2C0_SDA #3<br>I2C0_SCL #2   | FRC_DCLK #3<br>FRC_DOUT #2<br>FRC_DFRAME #1<br>MODEM_DCLK #3<br>MODEM_DIN #2<br>MODEM_DOUT #1<br>MODEM_ANT0 #0<br>MODEM_ANT1 #31  | PRS_CH6 #3<br>PRS_CH7 #2<br>PRS_CH8 #1<br>PRS_CH9 #0<br>ACMP0_O #3<br>ACMP1_O #3<br>GPIO_EM4WU8 |
| 29                  | PA4      | BUSCX [ADC0:<br>APORT3XCH12<br>ACMP0:<br>APORT3XCH12<br>ACMP1:<br>APORT3XCH12<br>IDAC0:<br>APORT1XCH12]<br><br>BUSDY [ADC0:<br>APORT4YCH12<br>ACMP0:<br>APORT4YCH12<br>ACMP1:<br>APORT4YCH12] | TIM0_CC0 #4<br>TIM0_CC1 #3<br>TIM0_CC2 #2<br>TIM0_CDTI0 #1<br>TIM0_CDTI1 #0<br>TIM0_CDTI2 #31<br>TIM1_CC0 #4<br>TIM1_CC1 #3<br>TIM1_CC2 #2<br>TIM1_CC3 #1 LE-<br>TIM0_OUT0 #4 LE-<br>TIM0_OUT1 #3<br>PCNT0_S0IN #4<br>PCNT0_S1IN #3    | US0_TX #4<br>US0_RX #3<br>US0_CLK #2<br>US0_CS #1<br>US0_CTS #0<br>US0_RTS #31<br>US1_TX #4<br>US1_RX #3<br>US1_CLK #2<br>US1_CS #1<br>US1_CTS #0<br>US1_RTS #31<br>LEU0_TX #4<br>LEU0_RX #3<br>I2C0_SDA #4<br>I2C0_SCL #3     | FRC_DCLK #4<br>FRC_DOUT #3<br>FRC_DFRAME #2<br>MODEM_DCLK #4<br>MODEM_DIN #3<br>MODEM_DOUT #2<br>MODEM_ANT0 #1<br>MODEM_ANT1 #0   | PRS_CH6 #4<br>PRS_CH7 #3<br>PRS_CH8 #2<br>PRS_CH9 #1<br>ACMP0_O #4<br>ACMP1_O #4                |



| QFN48 Pin# and Name |          | Pin Alternate Functionality / Description   |  |  |   |  |
|---------------------|----------|---|--|--|---|--|
| Pin #               | Pin Name | Analog  | Timers   | Communication  | Radio   | Other  |
| 30                  | PA5      | BUSCY [ADC0:<br>APORT3YCH13<br>ACMP0:<br>APORT3YCH13<br>ACMP1:<br>APORT3YCH13<br>IDAC0:<br>APORT1YCH13]<br><br>BUSDX [ADC0:<br>APORT4XCH13<br>ACMP0:<br>APORT4XCH13<br>ACMP1:<br>APORT4XCH13] | TIM0_CC0 #5<br>TIM0_CC1 #4<br>TIM0_CC2 #3<br>TIM0_CDTI0 #2<br>TIM0_CDTI1 #1<br>TIM0_CDTI2 #0<br>TIM1_CC0 #5<br>TIM1_CC1 #4<br>TIM1_CC2 #3<br>TIM1_CC3 #2 LE-<br>TIM0_OUT0 #5 LE-<br>TIM0_OUT1 #4<br>PCNT0_S0IN #5<br>PCNT0_S1IN #4 | US0_TX #5<br>US0_RX #4<br>US0_CLK #3<br>US0_CS #2<br>US0_CTS #1<br>US0_RTS #0<br>US1_TX #5<br>US1_RX #4<br>US1_CLK #3<br>US1_CS #2<br>US1_CTS #1<br>US1_RTS #0<br>LEU0_TX #5<br>LEU0_RX #4<br>I2C0_SDA #5<br>I2C0_SCL #4 | FRC_DCLK #5<br>FRC_DOUT #4<br>FRC_DFRAME #3<br>MODEM_DCLK #5<br>MODEM_DIN #4<br>MODEM_DOUT #3<br>MODEM_ANT0 #2<br>MODEM_ANT1 #1 | PRS_CH6 #5<br>PRS_CH7 #4<br>PRS_CH8 #3<br>PRS_CH9 #2<br>ACMP0_O #5<br>ACMP1_O #5 |
| 31                  | PB11     | BUSCY [ADC0:<br>APORT3YCH27<br>ACMP0:<br>APORT3YCH27<br>ACMP1:<br>APORT3YCH27<br>IDAC0:<br>APORT1YCH27]<br><br>BUSDX [ADC0:<br>APORT4XCH27<br>ACMP0:<br>APORT4XCH27<br>ACMP1:<br>APORT4XCH27] | TIM0_CC0 #6<br>TIM0_CC1 #5<br>TIM0_CC2 #4<br>TIM0_CDTI0 #3<br>TIM0_CDTI1 #2<br>TIM0_CDTI2 #1<br>TIM1_CC0 #6<br>TIM1_CC1 #5<br>TIM1_CC2 #4<br>TIM1_CC3 #3 LE-<br>TIM0_OUT0 #6 LE-<br>TIM0_OUT1 #5<br>PCNT0_S0IN #6<br>PCNT0_S1IN #5 | US0_TX #6<br>US0_RX #5<br>US0_CLK #4<br>US0_CS #3<br>US0_CTS #2<br>US0_RTS #1<br>US1_TX #6<br>US1_RX #5<br>US1_CLK #4<br>US1_CS #3<br>US1_CTS #2<br>US1_RTS #1<br>LEU0_TX #6<br>LEU0_RX #5<br>I2C0_SDA #6<br>I2C0_SCL #5 | FRC_DCLK #6<br>FRC_DOUT #5<br>FRC_DFRAME #4<br>MODEM_DCLK #6<br>MODEM_DIN #5<br>MODEM_DOUT #4<br>MODEM_ANT0 #3<br>MODEM_ANT1 #2 | PRS_CH6 #6<br>PRS_CH7 #5<br>PRS_CH8 #4<br>PRS_CH9 #3<br>ACMP0_O #6<br>ACMP1_O #6 |
| 32                  | PB12     | BUSCX [ADC0:<br>APORT3XCH28<br>ACMP0:<br>APORT3XCH28<br>ACMP1:<br>APORT3XCH28<br>IDAC0:<br>APORT1XCH28]<br><br>BUSDY [ADC0:<br>APORT4YCH28<br>ACMP0:<br>APORT4YCH28<br>ACMP1:<br>APORT4YCH28] | TIM0_CC0 #7<br>TIM0_CC1 #6<br>TIM0_CC2 #5<br>TIM0_CDTI0 #4<br>TIM0_CDTI1 #3<br>TIM0_CDTI2 #2<br>TIM1_CC0 #7<br>TIM1_CC1 #6<br>TIM1_CC2 #5<br>TIM1_CC3 #4 LE-<br>TIM0_OUT0 #7 LE-<br>TIM0_OUT1 #6<br>PCNT0_S0IN #7<br>PCNT0_S1IN #6 | US0_TX #7<br>US0_RX #6<br>US0_CLK #5<br>US0_CS #4<br>US0_CTS #3<br>US0_RTS #2<br>US1_TX #7<br>US1_RX #6<br>US1_CLK #5<br>US1_CS #4<br>US1_CTS #3<br>US1_RTS #2<br>LEU0_TX #7<br>LEU0_RX #6<br>I2C0_SDA #7<br>I2C0_SCL #6 | FRC_DCLK #7<br>FRC_DOUT #6<br>FRC_DFRAME #5<br>MODEM_DCLK #7<br>MODEM_DIN #6<br>MODEM_DOUT #5<br>MODEM_ANT0 #4<br>MODEM_ANT1 #3 | PRS_CH6 #7<br>PRS_CH7 #6<br>PRS_CH8 #5<br>PRS_CH9 #4<br>ACMP0_O #7<br>ACMP1_O #7 |

| QFN48 Pin# and Name |          | Pin Alternate Functionality / Description   |  |  |   |   |
|---------------------|----------|---|--|--|---|---|
| Pin #               | Pin Name | Analog  | Timers   | Communication  | Radio   | Other   |
| 33                  | PB13     | BUSCY [ADC0:<br>APORT3YCH29<br>ACMP0:<br>APORT3YCH29<br>ACMP1:<br>APORT3YCH29<br>IDAC0:<br>APORT1YCH29]<br><br>BUSDX [ADC0:<br>APORT4XCH29<br>ACMP0:<br>APORT4XCH29<br>ACMP1:<br>APORT4XCH29]                 | TIM0_CC0 #8<br>TIM0_CC1 #7<br>TIM0_CC2 #6<br>TIM0_CDT10 #5<br>TIM0_CDT11 #4<br>TIM0_CDT12 #3<br>TIM1_CC0 #8<br>TIM1_CC1 #7<br>TIM1_CC2 #6<br>TIM1_CC3 #5 LE-<br>TIM0_OUT0 #8 LE-<br>TIM0_OUT1 #7<br>PCNT0_S0IN #8<br>PCNT0_S1IN #7   | US0_TX #8<br>US0_RX #7<br>US0_CLK #6<br>US0_CS #5<br>US0_CTS #4<br>US0_RTS #3<br>US1_TX #8<br>US1_RX #7<br>US1_CLK #6<br>US1_CS #5<br>US1_CTS #4<br>US1_RTS #3<br>LEU0_TX #8<br>LEU0_RX #7<br>I2C0_SDA #8<br>I2C0_SCL #7     | FRC_DCLK #8<br>FRC_DOUT #7<br>FRC_DFRAME #6<br>MODEM_DCLK #8<br>MODEM_DIN #7<br>MODEM_DOUT #6<br>MODEM_ANT0 #5<br>MODEM_ANT1 #4   | PRS_CH6 #8<br>PRS_CH7 #7<br>PRS_CH8 #6<br>PRS_CH9 #5<br>ACMP0_O #8<br>ACMP1_O #8<br>DBG_SWO #1<br>GPIO_EM4WU9 |
| 34                  | AVDD     | Analog power supply.  |  |  |   |   |
| 35                  | PB14     | LFXTAL_N<br><br>BUSCX [ADC0:<br>APORT3XCH30<br>ACMP0:<br>APORT3XCH30<br>ACMP1:<br>APORT3XCH30<br>IDAC0:<br>APORT1XCH30]<br><br>BUSDY [ADC0:<br>APORT4YCH30<br>ACMP0:<br>APORT4YCH30<br>ACMP1:<br>APORT4YCH30] | TIM0_CC0 #9<br>TIM0_CC1 #8<br>TIM0_CC2 #7<br>TIM0_CDT10 #6<br>TIM0_CDT11 #5<br>TIM0_CDT12 #4<br>TIM1_CC0 #9<br>TIM1_CC1 #8<br>TIM1_CC2 #7<br>TIM1_CC3 #6 LE-<br>TIM0_OUT0 #9 LE-<br>TIM0_OUT1 #8<br>PCNT0_S0IN #9<br>PCNT0_S1IN #8   | US0_TX #9<br>US0_RX #8<br>US0_CLK #7<br>US0_CS #6<br>US0_CTS #5<br>US0_RTS #4<br>US1_TX #9<br>US1_RX #8<br>US1_CLK #7<br>US1_CS #6<br>US1_CTS #5<br>US1_RTS #4<br>LEU0_TX #9<br>LEU0_RX #8<br>I2C0_SDA #9<br>I2C0_SCL #8     | FRC_DCLK #9<br>FRC_DOUT #8<br>FRC_DFRAME #7<br>MODEM_DCLK #9<br>MODEM_DIN #8<br>MODEM_DOUT #7<br>MODEM_ANT0 #6<br>MODEM_ANT1 #5   | CMU_CLK1 #1<br>PRS_CH6 #9<br>PRS_CH7 #8<br>PRS_CH8 #7<br>PRS_CH9 #6<br>ACMP0_O #9<br>ACMP1_O #9               |
| 36                  | PB15     | LFXTAL_P<br><br>BUSCY [ADC0:<br>APORT3YCH31<br>ACMP0:<br>APORT3YCH31<br>ACMP1:<br>APORT3YCH31<br>IDAC0:<br>APORT1YCH31]<br><br>BUSDX [ADC0:<br>APORT4XCH31<br>ACMP0:<br>APORT4XCH31<br>ACMP1:<br>APORT4XCH31] | TIM0_CC0 #10<br>TIM0_CC1 #9<br>TIM0_CC2 #8<br>TIM0_CDT10 #7<br>TIM0_CDT11 #6<br>TIM0_CDT12 #5<br>TIM1_CC0 #10<br>TIM1_CC1 #9<br>TIM1_CC2 #8<br>TIM1_CC3 #7 LE-<br>TIM0_OUT0 #10<br>LETIM0_OUT1 #9<br>PCNT0_S0IN #10<br>PCNT0_S1IN #9 | US0_TX #10<br>US0_RX #9<br>US0_CLK #8<br>US0_CS #7<br>US0_CTS #6<br>US0_RTS #5<br>US1_TX #10<br>US1_RX #9<br>US1_CLK #8<br>US1_CS #7<br>US1_CTS #6<br>US1_RTS #5<br>LEU0_TX #10<br>LEU0_RX #9<br>I2C0_SDA #10<br>I2C0_SCL #9 | FRC_DCLK #10<br>FRC_DOUT #9<br>FRC_DFRAME #8<br>MODEM_DCLK #10<br>MODEM_DIN #9<br>MODEM_DOUT #8<br>MODEM_ANT0 #7<br>MODEM_ANT1 #6 | CMU_CLK0 #1<br>PRS_CH6 #10<br>PRS_CH7 #9<br>PRS_CH8 #8<br>PRS_CH9 #7<br>ACMP0_O #10<br>ACMP1_O #10            |
| 37                  | VREGVSS  | Voltage regulator VSS   |  |  |   |   |
| 38                  | VREGSW   | DCDC regulator switching node   |  |  |   |   |
| 39                  | VREGVDD  | Voltage regulator VDD input   |  |  |   |   |
| 40                  | DVDD     | Digital power supply.   |  |  |   |   |

| QFN48 Pin# and Name |          | Pin Alternate Functionality / Description  |  |  |  |  |
|---------------------|----------|--|--|--|--|--|
| Pin #               | Pin Name | Analog   | Timers   | Communication  | Radio  | Other  |
| 41                  | DECOUPLE | Decouple output for on-chip voltage regulator. An external decoupling capacitor is required at this pin.                         |  |  |  |  |
| 42                  | IOVDD    | Digital IO power supply.   |  |  |  |  |
| 43                  | PC6      | BUSAX [ADC0: APORT1XCH6 ACMP0: APORT1XCH6 ACMP1: APORT1XCH6]<br><br>BUSBY [ADC0: APORT2YCH6 ACMP0: APORT2YCH6 ACMP1: APORT2YCH6] | TIM0_CC0 #11<br>TIM0_CC1 #10<br>TIM0_CC2 #9<br>TIM0_CDT10 #8<br>TIM0_CDT11 #7<br>TIM0_CDT12 #6<br>TIM1_CC0 #11<br>TIM1_CC1 #10<br>TIM1_CC2 #9<br>TIM1_CC3 #8 LE-<br>TIM0_OUT0 #11<br>LETIM0_OUT1 #10<br>PCNT0_S0IN #11<br>PCNT0_S1IN #10     | US0_TX #11<br>US0_RX #10<br>US0_CLK #9<br>US0_CS #8<br>US0_CTS #7<br>US0_RTS #6<br>US1_TX #11<br>US1_RX #10<br>US1_CLK #9<br>US1_CS #8<br>US1_CTS #7<br>US1_RTS #6<br>LEU0_TX #11<br>LEU0_RX #10<br>I2C0_SDA #11<br>I2C0_SCL #10     | FRC_DCLK #11<br>FRC_DOUT #10<br>FRC_DFRAME #9<br>MODEM_DCLK #11<br>MODEM_DIN #10<br>MODEM_DOUT #9<br>MODEM_ANT0 #8<br>MODEM_ANT1 #7    | CMU_CLK0 #2<br>PRS_CH0 #8<br>PRS_CH9 #11<br>PRS_CH10 #0<br>PRS_CH11 #5<br>ACMP0_O #11<br>ACMP1_O #11 |
| 44                  | PC7      | BUSAY [ADC0: APORT1YCH7 ACMP0: APORT1YCH7 ACMP1: APORT1YCH7]<br><br>BUSBX [ADC0: APORT2XCH7 ACMP0: APORT2XCH7 ACMP1: APORT2XCH7] | TIM0_CC0 #12<br>TIM0_CC1 #11<br>TIM0_CC2 #10<br>TIM0_CDT10 #9<br>TIM0_CDT11 #8<br>TIM0_CDT12 #7<br>TIM1_CC0 #12<br>TIM1_CC1 #11<br>TIM1_CC2 #10<br>TIM1_CC3 #9 LE-<br>TIM0_OUT0 #12<br>LETIM0_OUT1 #11<br>PCNT0_S0IN #12<br>PCNT0_S1IN #11   | US0_TX #12<br>US0_RX #11<br>US0_CLK #10<br>US0_CS #9<br>US0_CTS #8<br>US0_RTS #7<br>US1_TX #12<br>US1_RX #11<br>US1_CLK #10<br>US1_CS #9<br>US1_CTS #8<br>US1_RTS #7<br>LEU0_TX #12<br>LEU0_RX #11<br>I2C0_SDA #12<br>I2C0_SCL #11   | FRC_DCLK #12<br>FRC_DOUT #11<br>FRC_DFRAME #10<br>MODEM_DCLK #12<br>MODEM_DIN #11<br>MODEM_DOUT #10<br>MODEM_ANT0 #9<br>MODEM_ANT1 #8  | CMU_CLK1 #2<br>PRS_CH0 #9<br>PRS_CH9 #12<br>PRS_CH10 #1<br>PRS_CH11 #0<br>ACMP0_O #12<br>ACMP1_O #12 |
| 45                  | PC8      | BUSAX [ADC0: APORT1XCH8 ACMP0: APORT1XCH8 ACMP1: APORT1XCH8]<br><br>BUSBY [ADC0: APORT2YCH8 ACMP0: APORT2YCH8 ACMP1: APORT2YCH8] | TIM0_CC0 #13<br>TIM0_CC1 #12<br>TIM0_CC2 #11<br>TIM0_CDT10 #10<br>TIM0_CDT11 #9<br>TIM0_CDT12 #8<br>TIM1_CC0 #13<br>TIM1_CC1 #12<br>TIM1_CC2 #11<br>TIM1_CC3 #10 LE-<br>TIM0_OUT0 #13<br>LETIM0_OUT1 #12<br>PCNT0_S0IN #13<br>PCNT0_S1IN #12 | US0_TX #13<br>US0_RX #12<br>US0_CLK #11<br>US0_CS #10<br>US0_CTS #9<br>US0_RTS #8<br>US1_TX #13<br>US1_RX #12<br>US1_CLK #11<br>US1_CS #10<br>US1_CTS #9<br>US1_RTS #8<br>LEU0_TX #13<br>LEU0_RX #12<br>I2C0_SDA #13<br>I2C0_SCL #12 | FRC_DCLK #13<br>FRC_DOUT #12<br>FRC_DFRAME #11<br>MODEM_DCLK #13<br>MODEM_DIN #12<br>MODEM_DOUT #11<br>MODEM_ANT0 #10<br>MODEM_ANT1 #9 | PRS_CH0 #10<br>PRS_CH9 #13<br>PRS_CH10 #2<br>PRS_CH11 #1<br>ACMP0_O #13<br>ACMP1_O #13               |

| QFN48 Pin# and Name |          | Pin Alternate Functionality / Description  |  |  |   |   |
|---------------------|----------|--|--|--|---|---|
| Pin #               | Pin Name | Analog   | Timers   | Communication  | Radio   | Other   |
| 46                  | PC9      | BUSAY [ADC0:<br>APORT1YCH9<br>ACMP0:<br>APORT1YCH9<br>ACMP1:<br>APORT1YCH9]<br><br>BUSBX [ADC0:<br>APORT2XCH9<br>ACMP0:<br>APORT2XCH9<br>ACMP1:<br>APORT2XCH9]       | TIM0_CC0 #14<br>TIM0_CC1 #13<br>TIM0_CC2 #12<br>TIM0_CDTI0 #11<br>TIM0_CDTI1 #10<br>TIM0_CDTI2 #9<br>TIM1_CC0 #14<br>TIM1_CC1 #13<br>TIM1_CC2 #12<br>TIM1_CC3 #11 LE-<br>TIM0_OUT0 #14<br>LETIM0_OUT1 #13<br>PCNT0_S0IN #14<br>PCNT0_S1IN #13  | US0_TX #14<br>US0_RX #13<br>US0_CLK #12<br>US0_CS #11<br>US0_CTS #10<br>US0_RTS #9<br>US1_TX #14<br>US1_RX #13<br>US1_CLK #12<br>US1_CS #11<br>US1_CTS #10<br>US1_RTS #9<br>LEU0_TX #14<br>LEU0_RX #13<br>I2C0_SDA #14<br>I2C0_SCL #13   | FRC_DCLK #14<br>FRC_DOUT #13<br>FRC_DFRAME #12<br>MODEM_DCLK #14<br>MODEM_DIN #13<br>MODEM_DOUT #12<br>MODEM_ANT0 #11<br>MODEM_ANT1 #10 | PRS_CH0 #11<br>PRS_CH9 #14<br>PRS_CH10 #3<br>PRS_CH11 #2<br>ACMP0_O #14<br>ACMP1_O #14                                |
| 47                  | PC10     | BUSAX [ADC0:<br>APORT1XCH10<br>ACMP0:<br>APORT1XCH10<br>ACMP1:<br>APORT1XCH10]<br><br>BUSBY [ADC0:<br>APORT2YCH10<br>ACMP0:<br>APORT2YCH10<br>ACMP1:<br>APORT2YCH10] | TIM0_CC0 #15<br>TIM0_CC1 #14<br>TIM0_CC2 #13<br>TIM0_CDTI0 #12<br>TIM0_CDTI1 #11<br>TIM0_CDTI2 #10<br>TIM1_CC0 #15<br>TIM1_CC1 #14<br>TIM1_CC2 #13<br>TIM1_CC3 #12 LE-<br>TIM0_OUT0 #15<br>LETIM0_OUT1 #14<br>PCNT0_S0IN #15<br>PCNT0_S1IN #14 | US0_TX #15<br>US0_RX #14<br>US0_CLK #13<br>US0_CS #12<br>US0_CTS #11<br>US0_RTS #10<br>US1_TX #15<br>US1_RX #14<br>US1_CLK #13<br>US1_CS #12<br>US1_CTS #11<br>US1_RTS #10<br>LEU0_TX #15<br>LEU0_RX #14<br>I2C0_SDA #15<br>I2C0_SCL #14 | FRC_DCLK #15<br>FRC_DOUT #14<br>FRC_DFRAME #13<br>MODEM_DCLK #15<br>MODEM_DIN #14<br>MODEM_DOUT #13<br>MODEM_ANT0 #12<br>MODEM_ANT1 #11 | CMU_CLK1 #3<br>PRS_CH0 #12<br>PRS_CH9 #15<br>PRS_CH10 #4<br>PRS_CH11 #3<br>ACMP0_O #15<br>ACMP1_O #15<br>GPIO_EM4WU12 |
| 48                  | PC11     | BUSAY [ADC0:<br>APORT1YCH11<br>ACMP0:<br>APORT1YCH11<br>ACMP1:<br>APORT1YCH11]<br><br>BUSBX [ADC0:<br>APORT2XCH11<br>ACMP0:<br>APORT2XCH11<br>ACMP1:<br>APORT2XCH11] | TIM0_CC0 #16<br>TIM0_CC1 #15<br>TIM0_CC2 #14<br>TIM0_CDTI0 #13<br>TIM0_CDTI1 #12<br>TIM0_CDTI2 #11<br>TIM1_CC0 #16<br>TIM1_CC1 #15<br>TIM1_CC2 #14<br>TIM1_CC3 #13 LE-<br>TIM0_OUT0 #16<br>LETIM0_OUT1 #15<br>PCNT0_S0IN #16<br>PCNT0_S1IN #15 | US0_TX #16<br>US0_RX #15<br>US0_CLK #14<br>US0_CS #13<br>US0_CTS #12<br>US0_RTS #11<br>US1_TX #16<br>US1_RX #15<br>US1_CLK #14<br>US1_CS #13<br>US1_CTS #12<br>US1_RTS #11<br>LEU0_TX #16<br>LEU0_RX #15<br>I2C0_SDA #16<br>I2C0_SCL #15 | FRC_DCLK #16<br>FRC_DOUT #15<br>FRC_DFRAME #14<br>MODEM_DCLK #16<br>MODEM_DIN #15<br>MODEM_DOUT #14<br>MODEM_ANT0 #13<br>MODEM_ANT1 #12 | CMU_CLK0 #3<br>PRS_CH0 #13<br>PRS_CH9 #16<br>PRS_CH10 #5<br>PRS_CH11 #4<br>ACMP0_O #16<br>ACMP1_O #16<br>DBG_SWO #3   |

### 6.1.1 EFR32FG1 QFN48 Sub-GHz GPIO Overview

The GPIO pins are organized as 16-bit ports indicated by letters A through F, and the individual pins on each port are indicated by a number from 15 down to 0.

**Table 6.2. QFN48 Sub-GHz GPIO Pinout**

| Port   | Pin 15    | Pin 14    | Pin 13    | Pin 12    | Pin 11    | Pin 10    | Pin 9    | Pin 8    | Pin 7    | Pin 6    | Pin 5    | Pin 4    | Pin 3    | Pin 2    | Pin 1    | Pin 0    |
|--------|-----------|-----------|-----------|-----------|-----------|-----------|----------|----------|----------|----------|----------|----------|----------|----------|----------|----------|
| Port A | -         | -         | -         | -         | -         | -         | -        | -        | -        | -        | PA5 (5V) | PA4 (5V) | PA3 (5V) | PA2 (5V) | PA1      | PA0      |
| Port B | PB15      | PB14      | PB13 (5V) | PB12 (5V) | PB11 (5V) | -         | -        | -        | -        | -        | -        | -        | -        | -        | -        | -        |
| Port C | -         | -         | -         | -         | PC11 (5V) | PC10 (5V) | PC9 (5V) | PC8 (5V) | PC7 (5V) | PC6 (5V) | -        | -        | -        | -        | -        | -        |
| Port D | PD15 (5V) | PD14 (5V) | PD13 (5V) | PD12 (5V) | PD11 (5V) | PD10 (5V) | PD9 (5V) | -        | -        | -        | -        | -        | -        | -        | -        | -        |
| Port F | -         | -         | -         | -         | -         | -         | -        | -        | PF7 (5V) | PF6 (5V) | PF5 (5V) | PF4 (5V) | PF3 (5V) | PF2 (5V) | PF1 (5V) | PF0 (5V) |

6.2 EFR32FG1 QFN48 2.4 GHz Definition

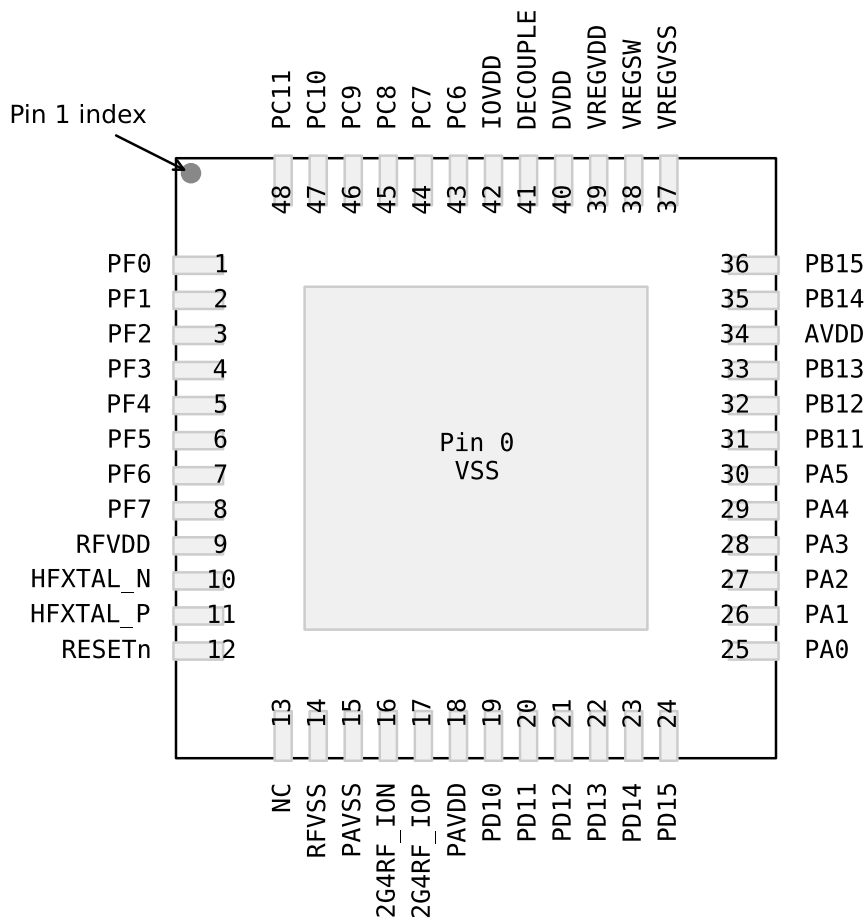


Figure 6.2. EFR32FG1 QFN48 2.4 GHz Pinout

Table 6.3. QFN48 2.4 GHz Device Pinout

| QFN48 Pin# and Name |          | Pin Alternate Functionality / Description  |  |  |   |  |
|---------------------|----------|--|--|--|---|--|
| Pin #               | Pin Name | Analog   | Timers   | Communication  | Radio   | Other  |
| 0                   | VSS      | Ground   |  |  |   |  |
| 1                   | PF0      | BUSAX [ADC0:<br>APORT1XCH16<br>ACMP0:<br>APORT1XCH16<br>ACMP1:<br>APORT1XCH16]<br><br>BUSBY [ADC0:<br>APORT2YCH16<br>ACMP0:<br>APORT2YCH16<br>ACMP1:<br>APORT2YCH16] | TIM0_CC0 #24<br>TIM0_CC1 #23<br>TIM0_CC2 #22<br>TIM0_CDTI0 #21<br>TIM0_CDTI1 #20<br>TIM0_CDTI2 #19<br>TIM1_CC0 #24<br>TIM1_CC1 #23<br>TIM1_CC2 #22<br>TIM1_CC3 #21 LE-<br>TIM0_OUT0 #24<br>LETIM0_OUT1 #23<br>PCNT0_S0IN #24<br>PCNT0_S1IN #23 | US0_TX #24<br>US0_RX #23<br>US0_CLK #22<br>US0_CS #21<br>US0_CTS #20<br>US0_RTS #19<br>US1_TX #24<br>US1_RX #23<br>US1_CLK #22<br>US1_CS #21<br>US1_CTS #20<br>US1_RTS #19<br>LEU0_TX #24<br>LEU0_RX #23<br>I2C0_SDA #24<br>I2C0_SCL #23 | FRC_DCLK #24<br>FRC_DOUT #23<br>FRC_DFRAME #22<br>MODEM_DCLK #24<br>MODEM_DIN #23<br>MODEM_DOUT #22<br>MODEM_ANT0 #21<br>MODEM_ANT1 #20 | PRS_CH0 #0<br>PRS_CH1 #7<br>PRS_CH2 #6<br>PRS_CH3 #5<br>ACMP0_O #24<br>ACMP1_O #24<br>DBG_SWCLKTCK #0  |
| 2                   | PF1      | BUSAY [ADC0:<br>APORT1YCH17<br>ACMP0:<br>APORT1YCH17<br>ACMP1:<br>APORT1YCH17]<br><br>BUSBX [ADC0:<br>APORT2XCH17<br>ACMP0:<br>APORT2XCH17<br>ACMP1:<br>APORT2XCH17] | TIM0_CC0 #25<br>TIM0_CC1 #24<br>TIM0_CC2 #23<br>TIM0_CDTI0 #22<br>TIM0_CDTI1 #21<br>TIM0_CDTI2 #20<br>TIM1_CC0 #25<br>TIM1_CC1 #24<br>TIM1_CC2 #23<br>TIM1_CC3 #22 LE-<br>TIM0_OUT0 #25<br>LETIM0_OUT1 #24<br>PCNT0_S0IN #25<br>PCNT0_S1IN #24 | US0_TX #25<br>US0_RX #24<br>US0_CLK #23<br>US0_CS #22<br>US0_CTS #21<br>US0_RTS #20<br>US1_TX #25<br>US1_RX #24<br>US1_CLK #23<br>US1_CS #22<br>US1_CTS #21<br>US1_RTS #20<br>LEU0_TX #25<br>LEU0_RX #24<br>I2C0_SDA #25<br>I2C0_SCL #24 | FRC_DCLK #25<br>FRC_DOUT #24<br>FRC_DFRAME #23<br>MODEM_DCLK #25<br>MODEM_DIN #24<br>MODEM_DOUT #23<br>MODEM_ANT0 #22<br>MODEM_ANT1 #21 | PRS_CH0 #1<br>PRS_CH1 #0<br>PRS_CH2 #7<br>PRS_CH3 #6<br>ACMP0_O #25<br>ACMP1_O #25<br>DBG_SWDIOTMS #0  |
| 3                   | PF2      | BUSAX [ADC0:<br>APORT1XCH18<br>ACMP0:<br>APORT1XCH18<br>ACMP1:<br>APORT1XCH18]<br><br>BUSBY [ADC0:<br>APORT2YCH18<br>ACMP0:<br>APORT2YCH18<br>ACMP1:<br>APORT2YCH18] | TIM0_CC0 #26<br>TIM0_CC1 #25<br>TIM0_CC2 #24<br>TIM0_CDTI0 #23<br>TIM0_CDTI1 #22<br>TIM0_CDTI2 #21<br>TIM1_CC0 #26<br>TIM1_CC1 #25<br>TIM1_CC2 #24<br>TIM1_CC3 #23 LE-<br>TIM0_OUT0 #26<br>LETIM0_OUT1 #25<br>PCNT0_S0IN #26<br>PCNT0_S1IN #25 | US0_TX #26<br>US0_RX #25<br>US0_CLK #24<br>US0_CS #23<br>US0_CTS #22<br>US0_RTS #21<br>US1_TX #26<br>US1_RX #25<br>US1_CLK #24<br>US1_CS #23<br>US1_CTS #22<br>US1_RTS #21<br>LEU0_TX #26<br>LEU0_RX #25<br>I2C0_SDA #26<br>I2C0_SCL #25 | FRC_DCLK #26<br>FRC_DOUT #25<br>FRC_DFRAME #24<br>MODEM_DCLK #26<br>MODEM_DIN #25<br>MODEM_DOUT #24<br>MODEM_ANT0 #23<br>MODEM_ANT1 #22 | CMU_CLK0 #6<br>PRS_CH0 #2<br>PRS_CH1 #1<br>PRS_CH2 #0<br>PRS_CH3 #7<br>ACMP0_O #26<br>ACMP1_O #26<br>DBG_TDO #0<br>DBG_SWO #0<br>GPIO_EM4WU0 |

| QFN48 Pin# and Name |          | Pin Alternate Functionality / Description  |  |  |   |   |
|---------------------|----------|--|--|--|---|---|
| Pin #               | Pin Name | Analog   | Timers   | Communication  | Radio   | Other   |
| 4                   | PF3      | BUSAY [ADC0:<br>APORT1YCH19<br>ACMP0:<br>APORT1YCH19<br>ACMP1:<br>APORT1YCH19]<br><br>BUSBX [ADC0:<br>APORT2XCH19<br>ACMP0:<br>APORT2XCH19<br>ACMP1:<br>APORT2XCH19] | TIM0_CC0 #27<br>TIM0_CC1 #26<br>TIM0_CC2 #25<br>TIM0_CDTI0 #24<br>TIM0_CDTI1 #23<br>TIM0_CDTI2 #22<br>TIM1_CC0 #27<br>TIM1_CC1 #26<br>TIM1_CC2 #25<br>TIM1_CC3 #24 LE-<br>TIM0_OUT0 #27<br>LETIM0_OUT1 #26<br>PCNT0_S0IN #27<br>PCNT0_S1IN #26 | US0_TX #27<br>US0_RX #26<br>US0_CLK #25<br>US0_CS #24<br>US0_CTS #23<br>US0_RTS #22<br>US1_TX #27<br>US1_RX #26<br>US1_CLK #25<br>US1_CS #24<br>US1_CTS #23<br>US1_RTS #22<br>LEU0_TX #27<br>LEU0_RX #26<br>I2C0_SDA #27<br>I2C0_SCL #26 | FRC_DCLK #27<br>FRC_DOUT #26<br>FRC_DFRAME #25<br>MODEM_DCLK #27<br>MODEM_DIN #26<br>MODEM_DOUT #25<br>MODEM_ANT0 #24<br>MODEM_ANT1 #23 | CMU_CLK1 #6<br>PRS_CH0 #3<br>PRS_CH1 #2<br>PRS_CH2 #1<br>PRS_CH3 #0<br>ACMP0_O #27<br>ACMP1_O #27<br>DBG_TDI #0 |
| 5                   | PF4      | BUSAX [ADC0:<br>APORT1XCH20<br>ACMP0:<br>APORT1XCH20<br>ACMP1:<br>APORT1XCH20]<br><br>BUSBY [ADC0:<br>APORT2YCH20<br>ACMP0:<br>APORT2YCH20<br>ACMP1:<br>APORT2YCH20] | TIM0_CC0 #28<br>TIM0_CC1 #27<br>TIM0_CC2 #26<br>TIM0_CDTI0 #25<br>TIM0_CDTI1 #24<br>TIM0_CDTI2 #23<br>TIM1_CC0 #28<br>TIM1_CC1 #27<br>TIM1_CC2 #26<br>TIM1_CC3 #25 LE-<br>TIM0_OUT0 #28<br>LETIM0_OUT1 #27<br>PCNT0_S0IN #28<br>PCNT0_S1IN #27 | US0_TX #28<br>US0_RX #27<br>US0_CLK #26<br>US0_CS #25<br>US0_CTS #24<br>US0_RTS #23<br>US1_TX #28<br>US1_RX #27<br>US1_CLK #26<br>US1_CS #25<br>US1_CTS #24<br>US1_RTS #23<br>LEU0_TX #28<br>LEU0_RX #27<br>I2C0_SDA #28<br>I2C0_SCL #27 | FRC_DCLK #28<br>FRC_DOUT #27<br>FRC_DFRAME #26<br>MODEM_DCLK #28<br>MODEM_DIN #27<br>MODEM_DOUT #26<br>MODEM_ANT0 #25<br>MODEM_ANT1 #24 | PRS_CH0 #4<br>PRS_CH1 #3<br>PRS_CH2 #2<br>PRS_CH3 #1<br>ACMP0_O #28<br>ACMP1_O #28                              |
| 6                   | PF5      | BUSAY [ADC0:<br>APORT1YCH21<br>ACMP0:<br>APORT1YCH21<br>ACMP1:<br>APORT1YCH21]<br><br>BUSBX [ADC0:<br>APORT2XCH21<br>ACMP0:<br>APORT2XCH21<br>ACMP1:<br>APORT2XCH21] | TIM0_CC0 #29<br>TIM0_CC1 #28<br>TIM0_CC2 #27<br>TIM0_CDTI0 #26<br>TIM0_CDTI1 #25<br>TIM0_CDTI2 #24<br>TIM1_CC0 #29<br>TIM1_CC1 #28<br>TIM1_CC2 #27<br>TIM1_CC3 #26 LE-<br>TIM0_OUT0 #29<br>LETIM0_OUT1 #28<br>PCNT0_S0IN #29<br>PCNT0_S1IN #28 | US0_TX #29<br>US0_RX #28<br>US0_CLK #27<br>US0_CS #26<br>US0_CTS #25<br>US0_RTS #24<br>US1_TX #29<br>US1_RX #28<br>US1_CLK #27<br>US1_CS #26<br>US1_CTS #25<br>US1_RTS #24<br>LEU0_TX #29<br>LEU0_RX #28<br>I2C0_SDA #29<br>I2C0_SCL #28 | FRC_DCLK #29<br>FRC_DOUT #28<br>FRC_DFRAME #27<br>MODEM_DCLK #29<br>MODEM_DIN #28<br>MODEM_DOUT #27<br>MODEM_ANT0 #26<br>MODEM_ANT1 #25 | PRS_CH0 #5<br>PRS_CH1 #4<br>PRS_CH2 #3<br>PRS_CH3 #2<br>ACMP0_O #29<br>ACMP1_O #29                              |



| QFN48 Pin# and Name |           | Pin Alternate Functionality / Description   |  |  |   |  |
|---------------------|-----------|---|--|--|---|--|
| Pin #               | Pin Name  | Analog  | Timers   | Communication  | Radio   | Other  |
| 7                   | PF6       | BUSAX [ADC0: APORT1XCH22 ACMP0: APORT1XCH22 ACMP1: APORT1XCH22]<br><br>BUSBY [ADC0: APORT2YCH22 ACMP0: APORT2YCH22 ACMP1: APORT2YCH22]  | TIM0_CC0 #30<br>TIM0_CC1 #29<br>TIM0_CC2 #28<br>TIM0_CDTI0 #27<br>TIM0_CDTI1 #26<br>TIM0_CDTI2 #25<br>TIM1_CC0 #30<br>TIM1_CC1 #29<br>TIM1_CC2 #28<br>TIM1_CC3 #27 LE-<br>TIM0_OUT0 #30<br>LETIM0_OUT1 #29<br>PCNT0_S0IN #30<br>PCNT0_S1IN #29 | US0_TX #30<br>US0_RX #29<br>US0_CLK #28<br>US0_CS #27<br>US0_CTS #26<br>US0_RTS #25<br>US1_TX #30<br>US1_RX #29<br>US1_CLK #28<br>US1_CS #27<br>US1_CTS #26<br>US1_RTS #25<br>LEU0_TX #30<br>LEU0_RX #29<br>I2C0_SDA #30<br>I2C0_SCL #29 | FRC_DCLK #30<br>FRC_DOUT #29<br>FRC_DFRAME #28<br>MODEM_DCLK #30<br>MODEM_DIN #29<br>MODEM_DOUT #28<br>MODEM_ANT0 #27<br>MODEM_ANT1 #26 | CMU_CLK1 #7<br>PRS_CH0 #6<br>PRS_CH1 #5<br>PRS_CH2 #4<br>PRS_CH3 #3<br>ACMP0_O #30<br>ACMP1_O #30                |
| 8                   | PF7       | BUSAY [ADC0: APORT1YCH23 ACMP0: APORT1YCH23 ACMP1: APORT1YCH23]<br><br>BUSBX [ADC0: APORT2XCH23 ACMP0: APORT2XCH23 ACMP1: APORT2XCH23]  | TIM0_CC0 #31<br>TIM0_CC1 #30<br>TIM0_CC2 #29<br>TIM0_CDTI0 #28<br>TIM0_CDTI1 #27<br>TIM0_CDTI2 #26<br>TIM1_CC0 #31<br>TIM1_CC1 #30<br>TIM1_CC2 #29<br>TIM1_CC3 #28 LE-<br>TIM0_OUT0 #31<br>LETIM0_OUT1 #30<br>PCNT0_S0IN #31<br>PCNT0_S1IN #30 | US0_TX #31<br>US0_RX #30<br>US0_CLK #29<br>US0_CS #28<br>US0_CTS #27<br>US0_RTS #26<br>US1_TX #31<br>US1_RX #30<br>US1_CLK #29<br>US1_CS #28<br>US1_CTS #27<br>US1_RTS #26<br>LEU0_TX #31<br>LEU0_RX #30<br>I2C0_SDA #31<br>I2C0_SCL #30 | FRC_DCLK #31<br>FRC_DOUT #30<br>FRC_DFRAME #29<br>MODEM_DCLK #31<br>MODEM_DIN #30<br>MODEM_DOUT #29<br>MODEM_ANT0 #28<br>MODEM_ANT1 #27 | CMU_CLK0 #7<br>PRS_CH0 #7<br>PRS_CH1 #6<br>PRS_CH2 #5<br>PRS_CH3 #4<br>ACMP0_O #31<br>ACMP1_O #31<br>GPIO_EM4WU1 |
| 9                   | RFVDD     | Radio power supply  |  |  |   |  |
| 10                  | HFXTAL_N  | High Frequency Crystal input pin.   |  |  |   |  |
| 11                  | HFXTAL_P  | High Frequency Crystal output pin.  |  |  |   |  |
| 12                  | RESETn    | Reset input, active low. To apply an external reset source to this pin, it is required to only drive this pin low during reset, and let the internal pull-up ensure that reset is released. |  |  |   |  |
| 13                  | NC        | No Connect.   |  |  |   |  |
| 14                  | RFVSS     | Radio Ground  |  |  |   |  |
| 15                  | PAVSS     | Power Amplifier (PA) voltage regulator VSS  |  |  |   |  |
| 16                  | 2G4RF_ION | 2.4 GHz Differential RF input/output, negative path.  |  |  |   |  |
| 17                  | 2G4RF_IOP | 2.4 GHz Differential RF input/output, positive path.  |  |  |   |  |
| 18                  | PAVDD     | Power Amplifier (PA) voltage regulator VDD input  |  |  |   |  |

| QFN48 Pin# and Name |          | Pin Alternate Functionality / Description  |  |  |   |  |
|---------------------|----------|--|--|--|---|--|
| Pin #               | Pin Name | Analog   | Timers   | Communication  | Radio   | Other  |
| 19                  | PD10     | BUSCX [ADC0:<br>APORT3XCH2<br>ACMP0:<br>APORT3XCH2<br>ACMP1:<br>APORT3XCH2<br>IDAC0:<br>APORT1XCH2]<br><br>BUSDY [ADC0:<br>APORT4YCH2<br>ACMP0:<br>APORT4YCH2<br>ACMP1:<br>APORT4YCH2] | TIM0_CC0 #18<br>TIM0_CC1 #17<br>TIM0_CC2 #16<br>TIM0_CDTI0 #15<br>TIM0_CDTI1 #14<br>TIM0_CDTI2 #13<br>TIM1_CC0 #18<br>TIM1_CC1 #17<br>TIM1_CC2 #16<br>TIM1_CC3 #15 LE-<br>TIM0_OUT0 #18<br>LETIM0_OUT1 #17<br>PCNT0_S0IN #18<br>PCNT0_S1IN #17 | US0_TX #18<br>US0_RX #17<br>US0_CLK #16<br>US0_CS #15<br>US0_CTS #14<br>US0_RTS #13<br>US1_TX #18<br>US1_RX #17<br>US1_CLK #16<br>US1_CS #15<br>US1_CTS #14<br>US1_RTS #13<br>LEU0_TX #18<br>LEU0_RX #17<br>I2C0_SDA #18<br>I2C0_SCL #17 | FRC_DCLK #18<br>FRC_DOUT #17<br>FRC_DFRAME #16<br>MODEM_DCLK #18<br>MODEM_DIN #17<br>MODEM_DOUT #16<br>MODEM_ANT0 #15<br>MODEM_ANT1 #14 | CMU_CLK1 #4<br>PRS_CH3 #9<br>PRS_CH4 #1<br>PRS_CH5 #0<br>PRS_CH6 #12<br>ACMP0_O #18<br>ACMP1_O #18 |
| 20                  | PD11     | BUSCY [ADC0:<br>APORT3YCH3<br>ACMP0:<br>APORT3YCH3<br>ACMP1:<br>APORT3YCH3<br>IDAC0:<br>APORT1YCH3]<br><br>BUSDX [ADC0:<br>APORT4XCH3<br>ACMP0:<br>APORT4XCH3<br>ACMP1:<br>APORT4XCH3] | TIM0_CC0 #19<br>TIM0_CC1 #18<br>TIM0_CC2 #17<br>TIM0_CDTI0 #16<br>TIM0_CDTI1 #15<br>TIM0_CDTI2 #14<br>TIM1_CC0 #19<br>TIM1_CC1 #18<br>TIM1_CC2 #17<br>TIM1_CC3 #16 LE-<br>TIM0_OUT0 #19<br>LETIM0_OUT1 #18<br>PCNT0_S0IN #19<br>PCNT0_S1IN #18 | US0_TX #19<br>US0_RX #18<br>US0_CLK #17<br>US0_CS #16<br>US0_CTS #15<br>US0_RTS #14<br>US1_TX #19<br>US1_RX #18<br>US1_CLK #17<br>US1_CS #16<br>US1_CTS #15<br>US1_RTS #14<br>LEU0_TX #19<br>LEU0_RX #18<br>I2C0_SDA #19<br>I2C0_SCL #18 | FRC_DCLK #19<br>FRC_DOUT #18<br>FRC_DFRAME #17<br>MODEM_DCLK #19<br>MODEM_DIN #18<br>MODEM_DOUT #17<br>MODEM_ANT0 #16<br>MODEM_ANT1 #15 | PRS_CH3 #10<br>PRS_CH4 #2<br>PRS_CH5 #1<br>PRS_CH6 #13<br>ACMP0_O #19<br>ACMP1_O #19               |
| 21                  | PD12     | BUSCX [ADC0:<br>APORT3XCH4<br>ACMP0:<br>APORT3XCH4<br>ACMP1:<br>APORT3XCH4<br>IDAC0:<br>APORT1XCH4]<br><br>BUSDY [ADC0:<br>APORT4YCH4<br>ACMP0:<br>APORT4YCH4<br>ACMP1:<br>APORT4YCH4] | TIM0_CC0 #20<br>TIM0_CC1 #19<br>TIM0_CC2 #18<br>TIM0_CDTI0 #17<br>TIM0_CDTI1 #16<br>TIM0_CDTI2 #15<br>TIM1_CC0 #20<br>TIM1_CC1 #19<br>TIM1_CC2 #18<br>TIM1_CC3 #17 LE-<br>TIM0_OUT0 #20<br>LETIM0_OUT1 #19<br>PCNT0_S0IN #20<br>PCNT0_S1IN #19 | US0_TX #20<br>US0_RX #19<br>US0_CLK #18<br>US0_CS #17<br>US0_CTS #16<br>US0_RTS #15<br>US1_TX #20<br>US1_RX #19<br>US1_CLK #18<br>US1_CS #17<br>US1_CTS #16<br>US1_RTS #15<br>LEU0_TX #20<br>LEU0_RX #19<br>I2C0_SDA #20<br>I2C0_SCL #19 | FRC_DCLK #20<br>FRC_DOUT #19<br>FRC_DFRAME #18<br>MODEM_DCLK #20<br>MODEM_DIN #19<br>MODEM_DOUT #18<br>MODEM_ANT0 #17<br>MODEM_ANT1 #16 | PRS_CH3 #11<br>PRS_CH4 #3<br>PRS_CH5 #2<br>PRS_CH6 #14<br>ACMP0_O #20<br>ACMP1_O #20               |

| QFN48 Pin# and Name |          | Pin Alternate Functionality / Description  |  |  |   |  |
|---------------------|----------|--|--|--|---|--|
| Pin #               | Pin Name | Analog   | Timers   | Communication  | Radio   | Other  |
| 22                  | PD13     | BUSCY [ADC0:<br>APORT3YCH5<br>ACMP0:<br>APORT3YCH5<br>ACMP1:<br>APORT3YCH5<br>IDAC0:<br>APORT1YCH5]<br><br>BUSDX [ADC0:<br>APORT4XCH5<br>ACMP0:<br>APORT4XCH5<br>ACMP1:<br>APORT4XCH5] | TIM0_CC0 #21<br>TIM0_CC1 #20<br>TIM0_CC2 #19<br>TIM0_CDTI0 #18<br>TIM0_CDTI1 #17<br>TIM0_CDTI2 #16<br>TIM1_CC0 #21<br>TIM1_CC1 #20<br>TIM1_CC2 #19<br>TIM1_CC3 #18 LE-<br>TIM0_OUT0 #21<br>LETIM0_OUT1 #20<br>PCNT0_S0IN #21<br>PCNT0_S1IN #20 | US0_TX #21<br>US0_RX #20<br>US0_CLK #19<br>US0_CS #18<br>US0_CTS #17<br>US0_RTS #16<br>US1_TX #21<br>US1_RX #20<br>US1_CLK #19<br>US1_CS #18<br>US1_CTS #17<br>US1_RTS #16<br>LEU0_TX #21<br>LEU0_RX #20<br>I2C0_SDA #21<br>I2C0_SCL #20 | FRC_DCLK #21<br>FRC_DOUT #20<br>FRC_DFRAME #19<br>MODEM_DCLK #21<br>MODEM_DIN #20<br>MODEM_DOUT #19<br>MODEM_ANT0 #18<br>MODEM_ANT1 #17 | PRS_CH3 #12<br>PRS_CH4 #4<br>PRS_CH5 #3<br>PRS_CH6 #15<br>ACMP0_O #21<br>ACMP1_O #21                               |
| 23                  | PD14     | BUSCX [ADC0:<br>APORT3XCH6<br>ACMP0:<br>APORT3XCH6<br>ACMP1:<br>APORT3XCH6<br>IDAC0:<br>APORT1XCH6]<br><br>BUSDY [ADC0:<br>APORT4YCH6<br>ACMP0:<br>APORT4YCH6<br>ACMP1:<br>APORT4YCH6] | TIM0_CC0 #22<br>TIM0_CC1 #21<br>TIM0_CC2 #20<br>TIM0_CDTI0 #19<br>TIM0_CDTI1 #18<br>TIM0_CDTI2 #17<br>TIM1_CC0 #22<br>TIM1_CC1 #21<br>TIM1_CC2 #20<br>TIM1_CC3 #19 LE-<br>TIM0_OUT0 #22<br>LETIM0_OUT1 #21<br>PCNT0_S0IN #22<br>PCNT0_S1IN #21 | US0_TX #22<br>US0_RX #21<br>US0_CLK #20<br>US0_CS #19<br>US0_CTS #18<br>US0_RTS #17<br>US1_TX #22<br>US1_RX #21<br>US1_CLK #20<br>US1_CS #19<br>US1_CTS #18<br>US1_RTS #17<br>LEU0_TX #22<br>LEU0_RX #21<br>I2C0_SDA #22<br>I2C0_SCL #21 | FRC_DCLK #22<br>FRC_DOUT #21<br>FRC_DFRAME #20<br>MODEM_DCLK #22<br>MODEM_DIN #21<br>MODEM_DOUT #20<br>MODEM_ANT0 #19<br>MODEM_ANT1 #18 | CMU_CLK0 #5<br>PRS_CH3 #13<br>PRS_CH4 #5<br>PRS_CH5 #4<br>PRS_CH6 #16<br>ACMP0_O #22<br>ACMP1_O #22<br>GPIO_EM4WU4 |
| 24                  | PD15     | BUSCY [ADC0:<br>APORT3YCH7<br>ACMP0:<br>APORT3YCH7<br>ACMP1:<br>APORT3YCH7<br>IDAC0:<br>APORT1YCH7]<br><br>BUSDX [ADC0:<br>APORT4XCH7<br>ACMP0:<br>APORT4XCH7<br>ACMP1:<br>APORT4XCH7] | TIM0_CC0 #23<br>TIM0_CC1 #22<br>TIM0_CC2 #21<br>TIM0_CDTI0 #20<br>TIM0_CDTI1 #19<br>TIM0_CDTI2 #18<br>TIM1_CC0 #23<br>TIM1_CC1 #22<br>TIM1_CC2 #21<br>TIM1_CC3 #20 LE-<br>TIM0_OUT0 #23<br>LETIM0_OUT1 #22<br>PCNT0_S0IN #23<br>PCNT0_S1IN #22 | US0_TX #23<br>US0_RX #22<br>US0_CLK #21<br>US0_CS #20<br>US0_CTS #19<br>US0_RTS #18<br>US1_TX #23<br>US1_RX #22<br>US1_CLK #21<br>US1_CS #20<br>US1_CTS #19<br>US1_RTS #18<br>LEU0_TX #23<br>LEU0_RX #22<br>I2C0_SDA #23<br>I2C0_SCL #22 | FRC_DCLK #23<br>FRC_DOUT #22<br>FRC_DFRAME #21<br>MODEM_DCLK #23<br>MODEM_DIN #22<br>MODEM_DOUT #21<br>MODEM_ANT0 #20<br>MODEM_ANT1 #19 | CMU_CLK1 #5<br>PRS_CH3 #14<br>PRS_CH4 #6<br>PRS_CH5 #5<br>PRS_CH6 #17<br>ACMP0_O #23<br>ACMP1_O #23<br>DBG_SWO #2  |

| QFN48 Pin# and Name |          | Pin Alternate Functionality / Description   |  |  |   |  |
|---------------------|----------|---|--|--|---|--|
| Pin #               | Pin Name | Analog  | Timers   | Communication  | Radio   | Other  |
| 25                  | PA0      | ADC0_EXTN<br><br>BUSCX [ADC0:<br>APORT3XCH8<br>ACMP0:<br>APORT3XCH8<br>ACMP1:<br>APORT3XCH8<br>IDAC0:<br>APORT1XCH8]<br><br>BUSDY [ADC0:<br>APORT4YCH8<br>ACMP0:<br>APORT4YCH8<br>ACMP1:<br>APORT4YCH8] | TIM0_CC0 #0<br>TIM0_CC1 #31<br>TIM0_CC2 #30<br>TIM0_CDTI0 #29<br>TIM0_CDTI1 #28<br>TIM0_CDTI2 #27<br>TIM1_CC0 #0<br>TIM1_CC1 #31<br>TIM1_CC2 #30<br>TIM1_CC3 #29 LE-<br>TIM0_OUT0 #0 LE-<br>TIM0_OUT1 #31<br>PCNT0_S0IN #0<br>PCNT0_S1IN #31 | US0_TX #0<br>US0_RX #31<br>US0_CLK #30<br>US0_CS #29<br>US0_CTS #28<br>US0_RTS #27<br>US1_TX #0<br>US1_RX #31<br>US1_CLK #30<br>US1_CS #29<br>US1_CTS #28<br>US1_RTS #27<br>LEU0_TX #0<br>LEU0_RX #31<br>I2C0_SDA #0<br>I2C0_SCL #31 | FRC_DCLK #0<br>FRC_DOUT #31<br>FRC_DFRAME #30<br>MODEM_DCLK #0<br>MODEM_DIN #31<br>MODEM_DOUT #30<br>MODEM_ANT0 #29<br>MODEM_ANT1 #28 | CMU_CLK1 #0<br>PRS_CH6 #0<br>PRS_CH7 #10<br>PRS_CH8 #9<br>PRS_CH9 #8<br>ACMP0_O #0<br>ACMP1_O #0 |
| 26                  | PA1      | ADC0_EXTP<br><br>BUSCY [ADC0:<br>APORT3YCH9<br>ACMP0:<br>APORT3YCH9<br>ACMP1:<br>APORT3YCH9<br>IDAC0:<br>APORT1YCH9]<br><br>BUSDX [ADC0:<br>APORT4XCH9<br>ACMP0:<br>APORT4XCH9<br>ACMP1:<br>APORT4XCH9] | TIM0_CC0 #1<br>TIM0_CC1 #0<br>TIM0_CC2 #31<br>TIM0_CDTI0 #30<br>TIM0_CDTI1 #29<br>TIM0_CDTI2 #28<br>TIM1_CC0 #1<br>TIM1_CC1 #0<br>TIM1_CC2 #31<br>TIM1_CC3 #30 LE-<br>TIM0_OUT0 #1 LE-<br>TIM0_OUT1 #0<br>PCNT0_S0IN #1<br>PCNT0_S1IN #0     | US0_TX #1<br>US0_RX #0<br>US0_CLK #31<br>US0_CS #30<br>US0_CTS #29<br>US0_RTS #28<br>US1_TX #1<br>US1_RX #0<br>US1_CLK #31<br>US1_CS #30<br>US1_CTS #29<br>US1_RTS #28<br>LEU0_TX #1<br>LEU0_RX #0<br>I2C0_SDA #1<br>I2C0_SCL #0     | FRC_DCLK #1<br>FRC_DOUT #0<br>FRC_DFRAME #31<br>MODEM_DCLK #1<br>MODEM_DIN #0<br>MODEM_DOUT #31<br>MODEM_ANT0 #30<br>MODEM_ANT1 #29   | CMU_CLK0 #0<br>PRS_CH6 #1<br>PRS_CH7 #0<br>PRS_CH8 #10<br>PRS_CH9 #9<br>ACMP0_O #1<br>ACMP1_O #1 |
| 27                  | PA2      | BUSCX [ADC0:<br>APORT3XCH10<br>ACMP0:<br>APORT3XCH10<br>ACMP1:<br>APORT3XCH10<br>IDAC0:<br>APORT1XCH10]<br><br>BUSDY [ADC0:<br>APORT4YCH10<br>ACMP0:<br>APORT4YCH10<br>ACMP1:<br>APORT4YCH10]           | TIM0_CC0 #2<br>TIM0_CC1 #1<br>TIM0_CC2 #0<br>TIM0_CDTI0 #31<br>TIM0_CDTI1 #30<br>TIM0_CDTI2 #29<br>TIM1_CC0 #2<br>TIM1_CC1 #1<br>TIM1_CC2 #0<br>TIM1_CC3 #31 LE-<br>TIM0_OUT0 #2 LE-<br>TIM0_OUT1 #1<br>PCNT0_S0IN #2<br>PCNT0_S1IN #1       | US0_TX #2<br>US0_RX #1<br>US0_CLK #0<br>US0_CS #31<br>US0_CTS #30<br>US0_RTS #29<br>US1_TX #2<br>US1_RX #1<br>US1_CLK #0<br>US1_CS #31<br>US1_CTS #30<br>US1_RTS #29<br>LEU0_TX #2<br>LEU0_RX #1<br>I2C0_SDA #2<br>I2C0_SCL #1       | FRC_DCLK #2<br>FRC_DOUT #1<br>FRC_DFRAME #0<br>MODEM_DCLK #2<br>MODEM_DIN #1<br>MODEM_DOUT #0<br>MODEM_ANT0 #31<br>MODEM_ANT1 #30     | PRS_CH6 #2<br>PRS_CH7 #1<br>PRS_CH8 #0<br>PRS_CH9 #10<br>ACMP0_O #2<br>ACMP1_O #2                |

| QFN48 Pin# and Name |          | Pin Alternate Functionality / Description   |  |  |  |   |
|---------------------|----------|---|--|--|--|---|
| Pin #               | Pin Name | Analog  | Timers   | Communication  | Radio  | Other   |
| 28                  | PA3      | BUSCY [ADC0:<br>APORT3YCH11<br>ACMP0:<br>APORT3YCH11<br>ACMP1:<br>APORT3YCH11<br>IDAC0:<br>APORT1YCH11]<br><br>BUSDX [ADC0:<br>APORT4XCH11<br>ACMP0:<br>APORT4XCH11<br>ACMP1:<br>APORT4XCH11] | TIM0_CC0 #3<br>TIM0_CC1 #2<br>TIM0_CC2 #1<br>TIM0_CDTI0 #0<br>TIM0_CDTI1 #31<br>TIM0_CDTI2 #30<br>TIM1_CC0 #3<br>TIM1_CC1 #2<br>TIM1_CC2 #1<br>TIM1_CC3 #0 LE-<br>TIM0_OUT0 #3 LE-<br>TIM0_OUT1 #2<br>PCNT0_S0IN #3<br>PCNT0_S1IN #2 | US0_TX #3<br>US0_RX #2<br>US0_CLK #1<br>US0_CS #0<br>US0_CTS #31<br>US0_RTS #30<br>US1_TX #3<br>US1_RX #2<br>US1_CLK #1<br>US1_CS #0<br>US1_CTS #31<br>US1_RTS #30<br>LEU0_TX #3<br>LEU0_RX #2<br>I2C0_SDA #3<br>I2C0_SCL #2 | FRC_DCLK #3<br>FRC_DOUT #2<br>FRC_DFRAME #1<br>MODEM_DCLK #3<br>MODEM_DIN #2<br>MODEM_DOUT #1<br>MODEM_ANT0 #0<br>MODEM_ANT1 #31 | PRS_CH6 #3<br>PRS_CH7 #2<br>PRS_CH8 #1<br>PRS_CH9 #0<br>ACMP0_O #3<br>ACMP1_O #3<br>GPIO_EM4WU8 |
| 29                  | PA4      | BUSCX [ADC0:<br>APORT3XCH12<br>ACMP0:<br>APORT3XCH12<br>ACMP1:<br>APORT3XCH12<br>IDAC0:<br>APORT1XCH12]<br><br>BUSDY [ADC0:<br>APORT4YCH12<br>ACMP0:<br>APORT4YCH12<br>ACMP1:<br>APORT4YCH12] | TIM0_CC0 #4<br>TIM0_CC1 #3<br>TIM0_CC2 #2<br>TIM0_CDTI0 #1<br>TIM0_CDTI1 #0<br>TIM0_CDTI2 #31<br>TIM1_CC0 #4<br>TIM1_CC1 #3<br>TIM1_CC2 #2<br>TIM1_CC3 #1 LE-<br>TIM0_OUT0 #4 LE-<br>TIM0_OUT1 #3<br>PCNT0_S0IN #4<br>PCNT0_S1IN #3  | US0_TX #4<br>US0_RX #3<br>US0_CLK #2<br>US0_CS #1<br>US0_CTS #0<br>US0_RTS #31<br>US1_TX #4<br>US1_RX #3<br>US1_CLK #2<br>US1_CS #1<br>US1_CTS #0<br>US1_RTS #31<br>LEU0_TX #4<br>LEU0_RX #3<br>I2C0_SDA #4<br>I2C0_SCL #3   | FRC_DCLK #4<br>FRC_DOUT #3<br>FRC_DFRAME #2<br>MODEM_DCLK #4<br>MODEM_DIN #3<br>MODEM_DOUT #2<br>MODEM_ANT0 #1<br>MODEM_ANT1 #0  | PRS_CH6 #4<br>PRS_CH7 #3<br>PRS_CH8 #2<br>PRS_CH9 #1<br>ACMP0_O #4<br>ACMP1_O #4                |
| 30                  | PA5      | BUSCY [ADC0:<br>APORT3YCH13<br>ACMP0:<br>APORT3YCH13<br>ACMP1:<br>APORT3YCH13<br>IDAC0:<br>APORT1YCH13]<br><br>BUSDX [ADC0:<br>APORT4XCH13<br>ACMP0:<br>APORT4XCH13<br>ACMP1:<br>APORT4XCH13] | TIM0_CC0 #5<br>TIM0_CC1 #4<br>TIM0_CC2 #3<br>TIM0_CDTI0 #2<br>TIM0_CDTI1 #1<br>TIM0_CDTI2 #0<br>TIM1_CC0 #5<br>TIM1_CC1 #4<br>TIM1_CC2 #3<br>TIM1_CC3 #2 LE-<br>TIM0_OUT0 #5 LE-<br>TIM0_OUT1 #4<br>PCNT0_S0IN #5<br>PCNT0_S1IN #4   | US0_TX #5<br>US0_RX #4<br>US0_CLK #3<br>US0_CS #2<br>US0_CTS #1<br>US0_RTS #0<br>US1_TX #5<br>US1_RX #4<br>US1_CLK #3<br>US1_CS #2<br>US1_CTS #1<br>US1_RTS #0<br>LEU0_TX #5<br>LEU0_RX #4<br>I2C0_SDA #5<br>I2C0_SCL #4     | FRC_DCLK #5<br>FRC_DOUT #4<br>FRC_DFRAME #3<br>MODEM_DCLK #5<br>MODEM_DIN #4<br>MODEM_DOUT #3<br>MODEM_ANT0 #2<br>MODEM_ANT1 #1  | PRS_CH6 #5<br>PRS_CH7 #4<br>PRS_CH8 #3<br>PRS_CH9 #2<br>ACMP0_O #5<br>ACMP1_O #5                |

| QFN48 Pin# and Name |          | Pin Alternate Functionality / Description  |  |  |   |   |
|---------------------|----------|--|--|--|---|---|
| Pin #               | Pin Name | Analog   | Timers   | Communication  | Radio   | Other   |
| 31                  | PB11     | <p>BUSCY [ADC0: APORT3YCH27 ACMP0: APORT3YCH27 ACMP1: APORT3YCH27 IDAC0: APORT1YCH27]</p> <p>BUSDX [ADC0: APORT4XCH27 ACMP0: APORT4XCH27 ACMP1: APORT4XCH27]</p> | <p>TIM0_CC0 #6<br/>TIM0_CC1 #5<br/>TIM0_CC2 #4<br/>TIM0_CDTI0 #3<br/>TIM0_CDTI1 #2<br/>TIM0_CDTI2 #1<br/>TIM1_CC0 #6<br/>TIM1_CC1 #5<br/>TIM1_CC2 #4<br/>TIM1_CC3 #3 LE-<br/>TIM0_OUT0 #6 LE-<br/>TIM0_OUT1 #5<br/>PCNT0_S0IN #6<br/>PCNT0_S1IN #5</p> | <p>US0_TX #6<br/>US0_RX #5<br/>US0_CLK #4<br/>US0_CS #3<br/>US0_CTS #2<br/>US0_RTS #1<br/>US1_TX #6<br/>US1_RX #5<br/>US1_CLK #4<br/>US1_CS #3<br/>US1_CTS #2<br/>US1_RTS #1<br/>LEU0_TX #6<br/>LEU0_RX #5<br/>I2C0_SDA #6<br/>I2C0_SCL #5</p> | <p>FRC_DCLK #6<br/>FRC_DOUT #5<br/>FRC_DFRAME #4<br/>MODEM_DCLK #6<br/>MODEM_DIN #5<br/>MODEM_DOUT #4<br/>MODEM_ANT0 #3<br/>MODEM_ANT1 #2</p> | <p>PRS_CH6 #6<br/>PRS_CH7 #5<br/>PRS_CH8 #4<br/>PRS_CH9 #3<br/>ACMP0_O #6<br/>ACMP1_O #6</p>                                |
| 32                  | PB12     | <p>BUSCX [ADC0: APORT3XCH28 ACMP0: APORT3XCH28 ACMP1: APORT3XCH28 IDAC0: APORT1XCH28]</p> <p>BUSDY [ADC0: APORT4YCH28 ACMP0: APORT4YCH28 ACMP1: APORT4YCH28]</p> | <p>TIM0_CC0 #7<br/>TIM0_CC1 #6<br/>TIM0_CC2 #5<br/>TIM0_CDTI0 #4<br/>TIM0_CDTI1 #3<br/>TIM0_CDTI2 #2<br/>TIM1_CC0 #7<br/>TIM1_CC1 #6<br/>TIM1_CC2 #5<br/>TIM1_CC3 #4 LE-<br/>TIM0_OUT0 #7 LE-<br/>TIM0_OUT1 #6<br/>PCNT0_S0IN #7<br/>PCNT0_S1IN #6</p> | <p>US0_TX #7<br/>US0_RX #6<br/>US0_CLK #5<br/>US0_CS #4<br/>US0_CTS #3<br/>US0_RTS #2<br/>US1_TX #7<br/>US1_RX #6<br/>US1_CLK #5<br/>US1_CS #4<br/>US1_CTS #3<br/>US1_RTS #2<br/>LEU0_TX #7<br/>LEU0_RX #6<br/>I2C0_SDA #7<br/>I2C0_SCL #6</p> | <p>FRC_DCLK #7<br/>FRC_DOUT #6<br/>FRC_DFRAME #5<br/>MODEM_DCLK #7<br/>MODEM_DIN #6<br/>MODEM_DOUT #5<br/>MODEM_ANT0 #4<br/>MODEM_ANT1 #3</p> | <p>PRS_CH6 #7<br/>PRS_CH7 #6<br/>PRS_CH8 #5<br/>PRS_CH9 #4<br/>ACMP0_O #7<br/>ACMP1_O #7</p>                                |
| 33                  | PB13     | <p>BUSCY [ADC0: APORT3YCH29 ACMP0: APORT3YCH29 ACMP1: APORT3YCH29 IDAC0: APORT1YCH29]</p> <p>BUSDX [ADC0: APORT4XCH29 ACMP0: APORT4XCH29 ACMP1: APORT4XCH29]</p> | <p>TIM0_CC0 #8<br/>TIM0_CC1 #7<br/>TIM0_CC2 #6<br/>TIM0_CDTI0 #5<br/>TIM0_CDTI1 #4<br/>TIM0_CDTI2 #3<br/>TIM1_CC0 #8<br/>TIM1_CC1 #7<br/>TIM1_CC2 #6<br/>TIM1_CC3 #5 LE-<br/>TIM0_OUT0 #8 LE-<br/>TIM0_OUT1 #7<br/>PCNT0_S0IN #8<br/>PCNT0_S1IN #7</p> | <p>US0_TX #8<br/>US0_RX #7<br/>US0_CLK #6<br/>US0_CS #5<br/>US0_CTS #4<br/>US0_RTS #3<br/>US1_TX #8<br/>US1_RX #7<br/>US1_CLK #6<br/>US1_CS #5<br/>US1_CTS #4<br/>US1_RTS #3<br/>LEU0_TX #8<br/>LEU0_RX #7<br/>I2C0_SDA #8<br/>I2C0_SCL #7</p> | <p>FRC_DCLK #8<br/>FRC_DOUT #7<br/>FRC_DFRAME #6<br/>MODEM_DCLK #8<br/>MODEM_DIN #7<br/>MODEM_DOUT #6<br/>MODEM_ANT0 #5<br/>MODEM_ANT1 #4</p> | <p>PRS_CH6 #8<br/>PRS_CH7 #7<br/>PRS_CH8 #6<br/>PRS_CH9 #5<br/>ACMP0_O #8<br/>ACMP1_O #8<br/>DBG_SWO #1<br/>GPIO_EM4WU9</p> |
| 34                  | AVDD     | Analog power supply.   |  |  |   |   |

| QFN48 Pin# and Name |          | Pin Alternate Functionality / Description   |  |  |   |  |
|---------------------|----------|---|--|--|---|--|
| Pin #               | Pin Name | Analog  | Timers   | Communication  | Radio   | Other  |
| 35                  | PB14     | LFXTAL_N<br><br>BUSCX [ADC0:<br>APORT3XCH30<br>ACMP0:<br>APORT3XCH30<br>ACMP1:<br>APORT3XCH30<br>IDAC0:<br>APORT1XCH30]<br><br>BUSDY [ADC0:<br>APORT4YCH30<br>ACMP0:<br>APORT4YCH30<br>ACMP1:<br>APORT4YCH30] | TIM0_CC0 #9<br>TIM0_CC1 #8<br>TIM0_CC2 #7<br>TIM0_CDT10 #6<br>TIM0_CDT11 #5<br>TIM0_CDT12 #4<br>TIM1_CC0 #9<br>TIM1_CC1 #8<br>TIM1_CC2 #7<br>TIM1_CC3 #6 LE-<br>TIM0_OUT0 #9 LE-<br>TIM0_OUT1 #8<br>PCNT0_S0IN #9<br>PCNT0_S1IN #8   | US0_TX #9<br>US0_RX #8<br>US0_CLK #7<br>US0_CS #6<br>US0_CTS #5<br>US0_RTS #4<br>US1_TX #9<br>US1_RX #8<br>US1_CLK #7<br>US1_CS #6<br>US1_CTS #5<br>US1_RTS #4<br>LEU0_TX #9<br>LEU0_RX #8<br>I2C0_SDA #9<br>I2C0_SCL #8     | FRC_DCLK #9<br>FRC_DOUT #8<br>FRC_DFRAME #7<br>MODEM_DCLK #9<br>MODEM_DIN #8<br>MODEM_DOUT #7<br>MODEM_ANT0 #6<br>MODEM_ANT1 #5   | CMU_CLK1 #1<br>PRS_CH6 #9<br>PRS_CH7 #8<br>PRS_CH8 #7<br>PRS_CH9 #6<br>ACMP0_O #9<br>ACMP1_O #9    |
| 36                  | PB15     | LFXTAL_P<br><br>BUSCY [ADC0:<br>APORT3YCH31<br>ACMP0:<br>APORT3YCH31<br>ACMP1:<br>APORT3YCH31<br>IDAC0:<br>APORT1YCH31]<br><br>BUSDX [ADC0:<br>APORT4XCH31<br>ACMP0:<br>APORT4XCH31<br>ACMP1:<br>APORT4XCH31] | TIM0_CC0 #10<br>TIM0_CC1 #9<br>TIM0_CC2 #8<br>TIM0_CDT10 #7<br>TIM0_CDT11 #6<br>TIM0_CDT12 #5<br>TIM1_CC0 #10<br>TIM1_CC1 #9<br>TIM1_CC2 #8<br>TIM1_CC3 #7 LE-<br>TIM0_OUT0 #10<br>LETIM0_OUT1 #9<br>PCNT0_S0IN #10<br>PCNT0_S1IN #9 | US0_TX #10<br>US0_RX #9<br>US0_CLK #8<br>US0_CS #7<br>US0_CTS #6<br>US0_RTS #5<br>US1_TX #10<br>US1_RX #9<br>US1_CLK #8<br>US1_CS #7<br>US1_CTS #6<br>US1_RTS #5<br>LEU0_TX #10<br>LEU0_RX #9<br>I2C0_SDA #10<br>I2C0_SCL #9 | FRC_DCLK #10<br>FRC_DOUT #9<br>FRC_DFRAME #8<br>MODEM_DCLK #10<br>MODEM_DIN #9<br>MODEM_DOUT #8<br>MODEM_ANT0 #7<br>MODEM_ANT1 #6 | CMU_CLK0 #1<br>PRS_CH6 #10<br>PRS_CH7 #9<br>PRS_CH8 #8<br>PRS_CH9 #7<br>ACMP0_O #10<br>ACMP1_O #10 |
| 37                  | VREGVSS  | Voltage regulator VSS   |  |  |   |  |
| 38                  | VREGSW   | DCDC regulator switching node   |  |  |   |  |
| 39                  | VREGVDD  | Voltage regulator VDD input   |  |  |   |  |
| 40                  | DVDD     | Digital power supply.   |  |  |   |  |
| 41                  | DECOUPLE | Decouple output for on-chip voltage regulator. An external decoupling capacitor is required at this pin.  |  |  |   |  |
| 42                  | IOVDD    | Digital IO power supply.  |  |  |   |  |

| QFN48 Pin# and Name |          | Pin Alternate Functionality / Description  |  |  |  |  |
|---------------------|----------|--|--|--|--|--|
| Pin #               | Pin Name | Analog   | Timers   | Communication  | Radio  | Other  |
| 43                  | PC6      | BUSAX [ADC0:<br>APORT1XCH6<br>ACMP0:<br>APORT1XCH6<br>ACMP1:<br>APORT1XCH6]<br><br>BUSBY [ADC0:<br>APORT2YCH6<br>ACMP0:<br>APORT2YCH6<br>ACMP1:<br>APORT2YCH6] | TIM0_CC0 #11<br>TIM0_CC1 #10<br>TIM0_CC2 #9<br>TIM0_CDTI0 #8<br>TIM0_CDTI1 #7<br>TIM0_CDTI2 #6<br>TIM1_CC0 #11<br>TIM1_CC1 #10<br>TIM1_CC2 #9<br>TIM1_CC3 #8 LE-<br>TIM0_OUT0 #11<br>LETIM0_OUT1 #10<br>PCNT0_S0IN #11<br>PCNT0_S1IN #10     | US0_TX #11<br>US0_RX #10<br>US0_CLK #9<br>US0_CS #8<br>US0_CTS #7<br>US0_RTS #6<br>US1_TX #11<br>US1_RX #10<br>US1_CLK #9<br>US1_CS #8<br>US1_CTS #7<br>US1_RTS #6<br>LEU0_TX #11<br>LEU0_RX #10<br>I2C0_SDA #11<br>I2C0_SCL #10     | FRC_DCLK #11<br>FRC_DOUT #10<br>FRC_DFRAME #9<br>MODEM_DCLK #11<br>MODEM_DIN #10<br>MODEM_DOUT #9<br>MODEM_ANT0 #8<br>MODEM_ANT1 #7    | CMU_CLK0 #2<br>PRS_CH0 #8<br>PRS_CH9 #11<br>PRS_CH10 #0<br>PRS_CH11 #5<br>ACMP0_O #11<br>ACMP1_O #11 |
| 44                  | PC7      | BUSAY [ADC0:<br>APORT1YCH7<br>ACMP0:<br>APORT1YCH7<br>ACMP1:<br>APORT1YCH7]<br><br>BUSBX [ADC0:<br>APORT2XCH7<br>ACMP0:<br>APORT2XCH7<br>ACMP1:<br>APORT2XCH7] | TIM0_CC0 #12<br>TIM0_CC1 #11<br>TIM0_CC2 #10<br>TIM0_CDTI0 #9<br>TIM0_CDTI1 #8<br>TIM0_CDTI2 #7<br>TIM1_CC0 #12<br>TIM1_CC1 #11<br>TIM1_CC2 #10<br>TIM1_CC3 #9 LE-<br>TIM0_OUT0 #12<br>LETIM0_OUT1 #11<br>PCNT0_S0IN #12<br>PCNT0_S1IN #11   | US0_TX #12<br>US0_RX #11<br>US0_CLK #10<br>US0_CS #9<br>US0_CTS #8<br>US0_RTS #7<br>US1_TX #12<br>US1_RX #11<br>US1_CLK #10<br>US1_CS #9<br>US1_CTS #8<br>US1_RTS #7<br>LEU0_TX #12<br>LEU0_RX #11<br>I2C0_SDA #12<br>I2C0_SCL #11   | FRC_DCLK #12<br>FRC_DOUT #11<br>FRC_DFRAME #10<br>MODEM_DCLK #12<br>MODEM_DIN #11<br>MODEM_DOUT #10<br>MODEM_ANT0 #9<br>MODEM_ANT1 #8  | CMU_CLK1 #2<br>PRS_CH0 #9<br>PRS_CH9 #12<br>PRS_CH10 #1<br>PRS_CH11 #0<br>ACMP0_O #12<br>ACMP1_O #12 |
| 45                  | PC8      | BUSAX [ADC0:<br>APORT1XCH8<br>ACMP0:<br>APORT1XCH8<br>ACMP1:<br>APORT1XCH8]<br><br>BUSBY [ADC0:<br>APORT2YCH8<br>ACMP0:<br>APORT2YCH8<br>ACMP1:<br>APORT2YCH8] | TIM0_CC0 #13<br>TIM0_CC1 #12<br>TIM0_CC2 #11<br>TIM0_CDTI0 #10<br>TIM0_CDTI1 #9<br>TIM0_CDTI2 #8<br>TIM1_CC0 #13<br>TIM1_CC1 #12<br>TIM1_CC2 #11<br>TIM1_CC3 #10 LE-<br>TIM0_OUT0 #13<br>LETIM0_OUT1 #12<br>PCNT0_S0IN #13<br>PCNT0_S1IN #12 | US0_TX #13<br>US0_RX #12<br>US0_CLK #11<br>US0_CS #10<br>US0_CTS #9<br>US0_RTS #8<br>US1_TX #13<br>US1_RX #12<br>US1_CLK #11<br>US1_CS #10<br>US1_CTS #9<br>US1_RTS #8<br>LEU0_TX #13<br>LEU0_RX #12<br>I2C0_SDA #13<br>I2C0_SCL #12 | FRC_DCLK #13<br>FRC_DOUT #12<br>FRC_DFRAME #11<br>MODEM_DCLK #13<br>MODEM_DIN #12<br>MODEM_DOUT #11<br>MODEM_ANT0 #10<br>MODEM_ANT1 #9 | PRS_CH0 #10<br>PRS_CH9 #13<br>PRS_CH10 #2<br>PRS_CH11 #1<br>ACMP0_O #13<br>ACMP1_O #13               |



| QFN48 Pin# and Name |          | Pin Alternate Functionality / Description  |  |  |   |   |
|---------------------|----------|--|--|--|---|---|
| Pin #               | Pin Name | Analog   | Timers   | Communication  | Radio   | Other   |
| 46                  | PC9      | BUSAY [ADC0:<br>APORT1YCH9<br>ACMP0:<br>APORT1YCH9<br>ACMP1:<br>APORT1YCH9]<br><br>BUSBX [ADC0:<br>APORT2XCH9<br>ACMP0:<br>APORT2XCH9<br>ACMP1:<br>APORT2XCH9]       | TIM0_CC0 #14<br>TIM0_CC1 #13<br>TIM0_CC2 #12<br>TIM0_CDTI0 #11<br>TIM0_CDTI1 #10<br>TIM0_CDTI2 #9<br>TIM1_CC0 #14<br>TIM1_CC1 #13<br>TIM1_CC2 #12<br>TIM1_CC3 #11 LE-<br>TIM0_OUT0 #14<br>LETIM0_OUT1 #13<br>PCNT0_S0IN #14<br>PCNT0_S1IN #13  | US0_TX #14<br>US0_RX #13<br>US0_CLK #12<br>US0_CS #11<br>US0_CTS #10<br>US0_RTS #9<br>US1_TX #14<br>US1_RX #13<br>US1_CLK #12<br>US1_CS #11<br>US1_CTS #10<br>US1_RTS #9<br>LEU0_TX #14<br>LEU0_RX #13<br>I2C0_SDA #14<br>I2C0_SCL #13   | FRC_DCLK #14<br>FRC_DOUT #13<br>FRC_DFRAME #12<br>MODEM_DCLK #14<br>MODEM_DIN #13<br>MODEM_DOUT #12<br>MODEM_ANT0 #11<br>MODEM_ANT1 #10 | PRS_CH0 #11<br>PRS_CH9 #14<br>PRS_CH10 #3<br>PRS_CH11 #2<br>ACMP0_O #14<br>ACMP1_O #14                                |
| 47                  | PC10     | BUSAX [ADC0:<br>APORT1XCH10<br>ACMP0:<br>APORT1XCH10<br>ACMP1:<br>APORT1XCH10]<br><br>BUSBY [ADC0:<br>APORT2YCH10<br>ACMP0:<br>APORT2YCH10<br>ACMP1:<br>APORT2YCH10] | TIM0_CC0 #15<br>TIM0_CC1 #14<br>TIM0_CC2 #13<br>TIM0_CDTI0 #12<br>TIM0_CDTI1 #11<br>TIM0_CDTI2 #10<br>TIM1_CC0 #15<br>TIM1_CC1 #14<br>TIM1_CC2 #13<br>TIM1_CC3 #12 LE-<br>TIM0_OUT0 #15<br>LETIM0_OUT1 #14<br>PCNT0_S0IN #15<br>PCNT0_S1IN #14 | US0_TX #15<br>US0_RX #14<br>US0_CLK #13<br>US0_CS #12<br>US0_CTS #11<br>US0_RTS #10<br>US1_TX #15<br>US1_RX #14<br>US1_CLK #13<br>US1_CS #12<br>US1_CTS #11<br>US1_RTS #10<br>LEU0_TX #15<br>LEU0_RX #14<br>I2C0_SDA #15<br>I2C0_SCL #14 | FRC_DCLK #15<br>FRC_DOUT #14<br>FRC_DFRAME #13<br>MODEM_DCLK #15<br>MODEM_DIN #14<br>MODEM_DOUT #13<br>MODEM_ANT0 #12<br>MODEM_ANT1 #11 | CMU_CLK1 #3<br>PRS_CH0 #12<br>PRS_CH9 #15<br>PRS_CH10 #4<br>PRS_CH11 #3<br>ACMP0_O #15<br>ACMP1_O #15<br>GPIO_EM4WU12 |
| 48                  | PC11     | BUSAY [ADC0:<br>APORT1YCH11<br>ACMP0:<br>APORT1YCH11<br>ACMP1:<br>APORT1YCH11]<br><br>BUSBX [ADC0:<br>APORT2XCH11<br>ACMP0:<br>APORT2XCH11<br>ACMP1:<br>APORT2XCH11] | TIM0_CC0 #16<br>TIM0_CC1 #15<br>TIM0_CC2 #14<br>TIM0_CDTI0 #13<br>TIM0_CDTI1 #12<br>TIM0_CDTI2 #11<br>TIM1_CC0 #16<br>TIM1_CC1 #15<br>TIM1_CC2 #14<br>TIM1_CC3 #13 LE-<br>TIM0_OUT0 #16<br>LETIM0_OUT1 #15<br>PCNT0_S0IN #16<br>PCNT0_S1IN #15 | US0_TX #16<br>US0_RX #15<br>US0_CLK #14<br>US0_CS #13<br>US0_CTS #12<br>US0_RTS #11<br>US1_TX #16<br>US1_RX #15<br>US1_CLK #14<br>US1_CS #13<br>US1_CTS #12<br>US1_RTS #11<br>LEU0_TX #16<br>LEU0_RX #15<br>I2C0_SDA #16<br>I2C0_SCL #15 | FRC_DCLK #16<br>FRC_DOUT #15<br>FRC_DFRAME #14<br>MODEM_DCLK #16<br>MODEM_DIN #15<br>MODEM_DOUT #14<br>MODEM_ANT0 #13<br>MODEM_ANT1 #12 | CMU_CLK0 #3<br>PRS_CH0 #13<br>PRS_CH9 #16<br>PRS_CH10 #5<br>PRS_CH11 #4<br>ACMP0_O #16<br>ACMP1_O #16<br>DBG_SWO #3   |

### 6.2.1 EFR32FG1 QFN48 2.4 GHz GPIO Overview

The GPIO pins are organized as 16-bit ports indicated by letters A through F, and the individual pins on each port are indicated by a number from 15 down to 0.

**Table 6.4. QFN48 2.4 GHz GPIO Pinout**

| Port   | Pin 15    | Pin 14    | Pin 13    | Pin 12    | Pin 11    | Pin 10    | Pin 9    | Pin 8    | Pin 7    | Pin 6    | Pin 5    | Pin 4    | Pin 3    | Pin 2    | Pin 1    | Pin 0    |
|--------|-----------|-----------|-----------|-----------|-----------|-----------|----------|----------|----------|----------|----------|----------|----------|----------|----------|----------|
| Port A | -         | -         | -         | -         | -         | -         | -        | -        | -        | -        | PA5 (5V) | PA4 (5V) | PA3 (5V) | PA2 (5V) | PA1      | PA0      |
| Port B | PB15      | PB14      | PB13 (5V) | PB12 (5V) | PB11 (5V) | -         | -        | -        | -        | -        | -        | -        | -        | -        | -        | -        |
| Port C | -         | -         | -         | -         | PC11 (5V) | PC10 (5V) | PC9 (5V) | PC8 (5V) | PC7 (5V) | PC6 (5V) | -        | -        | -        | -        | -        | -        |
| Port D | PD15 (5V) | PD14 (5V) | PD13 (5V) | PD12 (5V) | PD11 (5V) | PD10 (5V) | -        | -        | -        | -        | -        | -        | -        | -        | -        | -        |
| Port F | -         | -         | -         | -         | -         | -         | -        | -        | PF7 (5V) | PF6 (5V) | PF5 (5V) | PF4 (5V) | PF3 (5V) | PF2 (5V) | PF1 (5V) | PF0 (5V) |

### 6.3 EFR32FG1 QFN48 2.4 GHz and Sub-GHz Definition

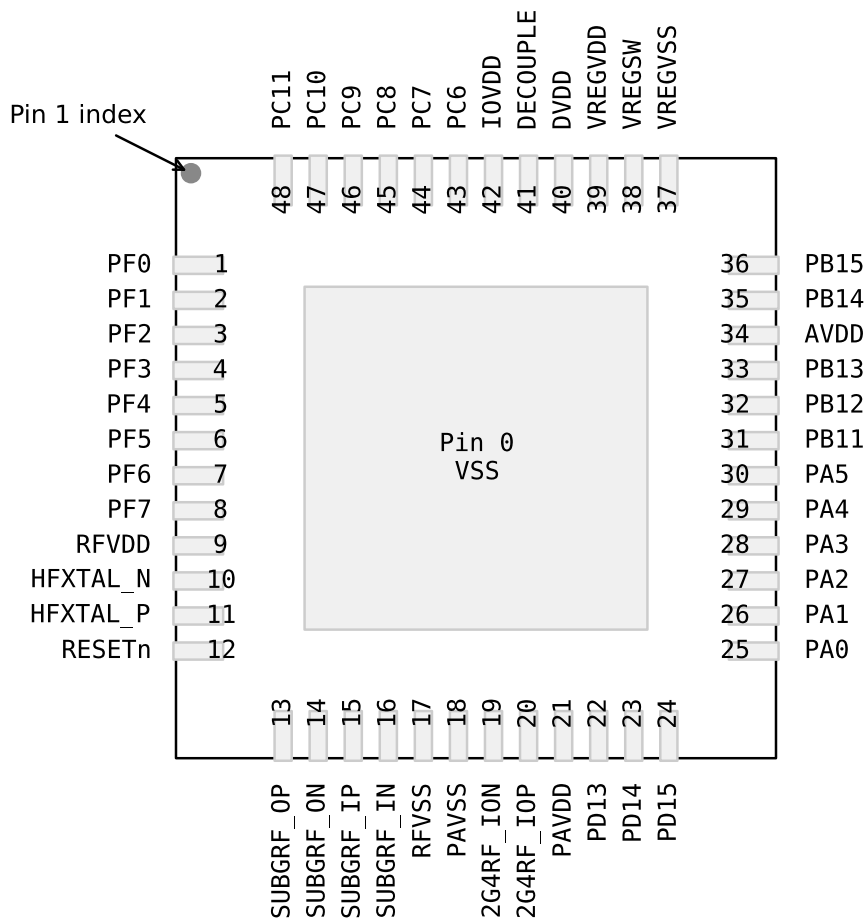


Figure 6.3. EFR32FG1 QFN48 2.4 GHz and Sub-GHz Pinout

**Table 6.5. QFN48 2.4 GHz and Sub-GHz Device Pinout**

| QFN48 Pin# and Name |          | Pin Alternate Functionality / Description  |  |  |   |  |
|---------------------|----------|--|--|--|---|--|
| Pin #               | Pin Name | Analog   | Timers   | Communication  | Radio   | Other  |
| 0                   | VSS      | Ground   |  |  |   |  |
| 1                   | PF0      | BUSAX [ADC0:<br>APORT1XCH16<br>ACMP0:<br>APORT1XCH16<br>ACMP1:<br>APORT1XCH16]<br><br>BUSBY [ADC0:<br>APORT2YCH16<br>ACMP0:<br>APORT2YCH16<br>ACMP1:<br>APORT2YCH16] | TIM0_CC0 #24<br>TIM0_CC1 #23<br>TIM0_CC2 #22<br>TIM0_CDTI0 #21<br>TIM0_CDTI1 #20<br>TIM0_CDTI2 #19<br>TIM1_CC0 #24<br>TIM1_CC1 #23<br>TIM1_CC2 #22<br>TIM1_CC3 #21 LE-<br>TIM0_OUT0 #24<br>LETIM0_OUT1 #23<br>PCNT0_S0IN #24<br>PCNT0_S1IN #23 | US0_TX #24<br>US0_RX #23<br>US0_CLK #22<br>US0_CS #21<br>US0_CTS #20<br>US0_RTS #19<br>US1_TX #24<br>US1_RX #23<br>US1_CLK #22<br>US1_CS #21<br>US1_CTS #20<br>US1_RTS #19<br>LEU0_TX #24<br>LEU0_RX #23<br>I2C0_SDA #24<br>I2C0_SCL #23 | FRC_DCLK #24<br>FRC_DOUT #23<br>FRC_DFRAME #22<br>MODEM_DCLK #24<br>MODEM_DIN #23<br>MODEM_DOUT #22<br>MODEM_ANT0 #21<br>MODEM_ANT1 #20 | PRS_CH0 #0<br>PRS_CH1 #7<br>PRS_CH2 #6<br>PRS_CH3 #5<br>ACMP0_O #24<br>ACMP1_O #24<br>DBG_SWCLKTCK #0  |
| 2                   | PF1      | BUSAY [ADC0:<br>APORT1YCH17<br>ACMP0:<br>APORT1YCH17<br>ACMP1:<br>APORT1YCH17]<br><br>BUSBX [ADC0:<br>APORT2XCH17<br>ACMP0:<br>APORT2XCH17<br>ACMP1:<br>APORT2XCH17] | TIM0_CC0 #25<br>TIM0_CC1 #24<br>TIM0_CC2 #23<br>TIM0_CDTI0 #22<br>TIM0_CDTI1 #21<br>TIM0_CDTI2 #20<br>TIM1_CC0 #25<br>TIM1_CC1 #24<br>TIM1_CC2 #23<br>TIM1_CC3 #22 LE-<br>TIM0_OUT0 #25<br>LETIM0_OUT1 #24<br>PCNT0_S0IN #25<br>PCNT0_S1IN #24 | US0_TX #25<br>US0_RX #24<br>US0_CLK #23<br>US0_CS #22<br>US0_CTS #21<br>US0_RTS #20<br>US1_TX #25<br>US1_RX #24<br>US1_CLK #23<br>US1_CS #22<br>US1_CTS #21<br>US1_RTS #20<br>LEU0_TX #25<br>LEU0_RX #24<br>I2C0_SDA #25<br>I2C0_SCL #24 | FRC_DCLK #25<br>FRC_DOUT #24<br>FRC_DFRAME #23<br>MODEM_DCLK #25<br>MODEM_DIN #24<br>MODEM_DOUT #23<br>MODEM_ANT0 #22<br>MODEM_ANT1 #21 | PRS_CH0 #1<br>PRS_CH1 #0<br>PRS_CH2 #7<br>PRS_CH3 #6<br>ACMP0_O #25<br>ACMP1_O #25<br>DBG_SWDIOTMS #0  |
| 3                   | PF2      | BUSAX [ADC0:<br>APORT1XCH18<br>ACMP0:<br>APORT1XCH18<br>ACMP1:<br>APORT1XCH18]<br><br>BUSBY [ADC0:<br>APORT2YCH18<br>ACMP0:<br>APORT2YCH18<br>ACMP1:<br>APORT2YCH18] | TIM0_CC0 #26<br>TIM0_CC1 #25<br>TIM0_CC2 #24<br>TIM0_CDTI0 #23<br>TIM0_CDTI1 #22<br>TIM0_CDTI2 #21<br>TIM1_CC0 #26<br>TIM1_CC1 #25<br>TIM1_CC2 #24<br>TIM1_CC3 #23 LE-<br>TIM0_OUT0 #26<br>LETIM0_OUT1 #25<br>PCNT0_S0IN #26<br>PCNT0_S1IN #25 | US0_TX #26<br>US0_RX #25<br>US0_CLK #24<br>US0_CS #23<br>US0_CTS #22<br>US0_RTS #21<br>US1_TX #26<br>US1_RX #25<br>US1_CLK #24<br>US1_CS #23<br>US1_CTS #22<br>US1_RTS #21<br>LEU0_TX #26<br>LEU0_RX #25<br>I2C0_SDA #26<br>I2C0_SCL #25 | FRC_DCLK #26<br>FRC_DOUT #25<br>FRC_DFRAME #24<br>MODEM_DCLK #26<br>MODEM_DIN #25<br>MODEM_DOUT #24<br>MODEM_ANT0 #23<br>MODEM_ANT1 #22 | CMU_CLK0 #6<br>PRS_CH0 #2<br>PRS_CH1 #1<br>PRS_CH2 #0<br>PRS_CH3 #7<br>ACMP0_O #26<br>ACMP1_O #26<br>DBG_TDO #0<br>DBG_SWO #0<br>GPIO_EM4WU0 |

| QFN48 Pin# and Name |          | Pin Alternate Functionality / Description  |  |  |   |   |
|---------------------|----------|--|--|--|---|---|
| Pin #               | Pin Name | Analog   | Timers   | Communication  | Radio   | Other   |
| 4                   | PF3      | BUSAY [ADC0:<br>APORT1YCH19<br>ACMP0:<br>APORT1YCH19<br>ACMP1:<br>APORT1YCH19]<br><br>BUSBX [ADC0:<br>APORT2XCH19<br>ACMP0:<br>APORT2XCH19<br>ACMP1:<br>APORT2XCH19] | TIM0_CC0 #27<br>TIM0_CC1 #26<br>TIM0_CC2 #25<br>TIM0_CDTI0 #24<br>TIM0_CDTI1 #23<br>TIM0_CDTI2 #22<br>TIM1_CC0 #27<br>TIM1_CC1 #26<br>TIM1_CC2 #25<br>TIM1_CC3 #24 LE-<br>TIM0_OUT0 #27<br>LETIM0_OUT1 #26<br>PCNT0_S0IN #27<br>PCNT0_S1IN #26 | US0_TX #27<br>US0_RX #26<br>US0_CLK #25<br>US0_CS #24<br>US0_CTS #23<br>US0_RTS #22<br>US1_TX #27<br>US1_RX #26<br>US1_CLK #25<br>US1_CS #24<br>US1_CTS #23<br>US1_RTS #22<br>LEU0_TX #27<br>LEU0_RX #26<br>I2C0_SDA #27<br>I2C0_SCL #26 | FRC_DCLK #27<br>FRC_DOUT #26<br>FRC_DFRAME #25<br>MODEM_DCLK #27<br>MODEM_DIN #26<br>MODEM_DOUT #25<br>MODEM_ANT0 #24<br>MODEM_ANT1 #23 | CMU_CLK1 #6<br>PRS_CH0 #3<br>PRS_CH1 #2<br>PRS_CH2 #1<br>PRS_CH3 #0<br>ACMP0_O #27<br>ACMP1_O #27<br>DBG_TDI #0 |
| 5                   | PF4      | BUSAX [ADC0:<br>APORT1XCH20<br>ACMP0:<br>APORT1XCH20<br>ACMP1:<br>APORT1XCH20]<br><br>BUSBY [ADC0:<br>APORT2YCH20<br>ACMP0:<br>APORT2YCH20<br>ACMP1:<br>APORT2YCH20] | TIM0_CC0 #28<br>TIM0_CC1 #27<br>TIM0_CC2 #26<br>TIM0_CDTI0 #25<br>TIM0_CDTI1 #24<br>TIM0_CDTI2 #23<br>TIM1_CC0 #28<br>TIM1_CC1 #27<br>TIM1_CC2 #26<br>TIM1_CC3 #25 LE-<br>TIM0_OUT0 #28<br>LETIM0_OUT1 #27<br>PCNT0_S0IN #28<br>PCNT0_S1IN #27 | US0_TX #28<br>US0_RX #27<br>US0_CLK #26<br>US0_CS #25<br>US0_CTS #24<br>US0_RTS #23<br>US1_TX #28<br>US1_RX #27<br>US1_CLK #26<br>US1_CS #25<br>US1_CTS #24<br>US1_RTS #23<br>LEU0_TX #28<br>LEU0_RX #27<br>I2C0_SDA #28<br>I2C0_SCL #27 | FRC_DCLK #28<br>FRC_DOUT #27<br>FRC_DFRAME #26<br>MODEM_DCLK #28<br>MODEM_DIN #27<br>MODEM_DOUT #26<br>MODEM_ANT0 #25<br>MODEM_ANT1 #24 | PRS_CH0 #4<br>PRS_CH1 #3<br>PRS_CH2 #2<br>PRS_CH3 #1<br>ACMP0_O #28<br>ACMP1_O #28                              |
| 6                   | PF5      | BUSAY [ADC0:<br>APORT1YCH21<br>ACMP0:<br>APORT1YCH21<br>ACMP1:<br>APORT1YCH21]<br><br>BUSBX [ADC0:<br>APORT2XCH21<br>ACMP0:<br>APORT2XCH21<br>ACMP1:<br>APORT2XCH21] | TIM0_CC0 #29<br>TIM0_CC1 #28<br>TIM0_CC2 #27<br>TIM0_CDTI0 #26<br>TIM0_CDTI1 #25<br>TIM0_CDTI2 #24<br>TIM1_CC0 #29<br>TIM1_CC1 #28<br>TIM1_CC2 #27<br>TIM1_CC3 #26 LE-<br>TIM0_OUT0 #29<br>LETIM0_OUT1 #28<br>PCNT0_S0IN #29<br>PCNT0_S1IN #28 | US0_TX #29<br>US0_RX #28<br>US0_CLK #27<br>US0_CS #26<br>US0_CTS #25<br>US0_RTS #24<br>US1_TX #29<br>US1_RX #28<br>US1_CLK #27<br>US1_CS #26<br>US1_CTS #25<br>US1_RTS #24<br>LEU0_TX #29<br>LEU0_RX #28<br>I2C0_SDA #29<br>I2C0_SCL #28 | FRC_DCLK #29<br>FRC_DOUT #28<br>FRC_DFRAME #27<br>MODEM_DCLK #29<br>MODEM_DIN #28<br>MODEM_DOUT #27<br>MODEM_ANT0 #26<br>MODEM_ANT1 #25 | PRS_CH0 #5<br>PRS_CH1 #4<br>PRS_CH2 #3<br>PRS_CH3 #2<br>ACMP0_O #29<br>ACMP1_O #29                              |

| QFN48 Pin# and Name |           | Pin Alternate Functionality / Description   |  |  |   |  |
|---------------------|-----------|---|--|--|---|--|
| Pin #               | Pin Name  | Analog  | Timers   | Communication  | Radio   | Other  |
| 7                   | PF6       | BUSAX [ADC0: APORT1XCH22 ACMP0: APORT1XCH22 ACMP1: APORT1XCH22]<br><br>BUSBY [ADC0: APORT2YCH22 ACMP0: APORT2YCH22 ACMP1: APORT2YCH22]  | TIM0_CC0 #30<br>TIM0_CC1 #29<br>TIM0_CC2 #28<br>TIM0_CDTI0 #27<br>TIM0_CDTI1 #26<br>TIM0_CDTI2 #25<br>TIM1_CC0 #30<br>TIM1_CC1 #29<br>TIM1_CC2 #28<br>TIM1_CC3 #27 LE-<br>TIM0_OUT0 #30<br>LETIM0_OUT1 #29<br>PCNT0_S0IN #30<br>PCNT0_S1IN #29 | US0_TX #30<br>US0_RX #29<br>US0_CLK #28<br>US0_CS #27<br>US0_CTS #26<br>US0_RTS #25<br>US1_TX #30<br>US1_RX #29<br>US1_CLK #28<br>US1_CS #27<br>US1_CTS #26<br>US1_RTS #25<br>LEU0_TX #30<br>LEU0_RX #29<br>I2C0_SDA #30<br>I2C0_SCL #29 | FRC_DCLK #30<br>FRC_DOUT #29<br>FRC_DFRAME #28<br>MODEM_DCLK #30<br>MODEM_DIN #29<br>MODEM_DOUT #28<br>MODEM_ANT0 #27<br>MODEM_ANT1 #26 | CMU_CLK1 #7<br>PRS_CH0 #6<br>PRS_CH1 #5<br>PRS_CH2 #4<br>PRS_CH3 #3<br>ACMP0_O #30<br>ACMP1_O #30                |
| 8                   | PF7       | BUSAY [ADC0: APORT1YCH23 ACMP0: APORT1YCH23 ACMP1: APORT1YCH23]<br><br>BUSBX [ADC0: APORT2XCH23 ACMP0: APORT2XCH23 ACMP1: APORT2XCH23]  | TIM0_CC0 #31<br>TIM0_CC1 #30<br>TIM0_CC2 #29<br>TIM0_CDTI0 #28<br>TIM0_CDTI1 #27<br>TIM0_CDTI2 #26<br>TIM1_CC0 #31<br>TIM1_CC1 #30<br>TIM1_CC2 #29<br>TIM1_CC3 #28 LE-<br>TIM0_OUT0 #31<br>LETIM0_OUT1 #30<br>PCNT0_S0IN #31<br>PCNT0_S1IN #30 | US0_TX #31<br>US0_RX #30<br>US0_CLK #29<br>US0_CS #28<br>US0_CTS #27<br>US0_RTS #26<br>US1_TX #31<br>US1_RX #30<br>US1_CLK #29<br>US1_CS #28<br>US1_CTS #27<br>US1_RTS #26<br>LEU0_TX #31<br>LEU0_RX #30<br>I2C0_SDA #31<br>I2C0_SCL #30 | FRC_DCLK #31<br>FRC_DOUT #30<br>FRC_DFRAME #29<br>MODEM_DCLK #31<br>MODEM_DIN #30<br>MODEM_DOUT #29<br>MODEM_ANT0 #28<br>MODEM_ANT1 #27 | CMU_CLK0 #7<br>PRS_CH0 #7<br>PRS_CH1 #6<br>PRS_CH2 #5<br>PRS_CH3 #4<br>ACMP0_O #31<br>ACMP1_O #31<br>GPIO_EM4WU1 |
| 9                   | RFVDD     | Radio power supply  |  |  |   |  |
| 10                  | HFXTAL_N  | High Frequency Crystal input pin.   |  |  |   |  |
| 11                  | HFXTAL_P  | High Frequency Crystal output pin.  |  |  |   |  |
| 12                  | RESETn    | Reset input, active low. To apply an external reset source to this pin, it is required to only drive this pin low during reset, and let the internal pull-up ensure that reset is released. |  |  |   |  |
| 13                  | SUBGRF_OP | Sub GHz Differential RF output, positive path.  |  |  |   |  |
| 14                  | SUBGRF_ON | Sub GHz Differential RF output, negative path.  |  |  |   |  |
| 15                  | SUBGRF_IP | Sub GHz Differential RF input, positive path.   |  |  |   |  |
| 16                  | SUBGRF_IN | Sub GHz Differential RF input, negative path.   |  |  |   |  |
| 17                  | RFVSS     | Radio Ground  |  |  |   |  |
| 18                  | PAVSS     | Power Amplifier (PA) voltage regulator VSS  |  |  |   |  |
| 19                  | 2G4RF_ION | 2.4 GHz Differential RF input/output, negative path.  |  |  |   |  |
| 20                  | 2G4RF_IOP | 2.4 GHz Differential RF input/output, positive path.  |  |  |   |  |
| 21                  | PAVDD     | Power Amplifier (PA) voltage regulator VDD input  |  |  |   |  |

| QFN48 Pin# and Name |          | Pin Alternate Functionality / Description  |  |  |   |  |
|---------------------|----------|--|--|--|---|--|
| Pin #               | Pin Name | Analog   | Timers   | Communication  | Radio   | Other  |
| 22                  | PD13     | BUSCY [ADC0:<br>APORT3YCH5<br>ACMP0:<br>APORT3YCH5<br>ACMP1:<br>APORT3YCH5<br>IDAC0:<br>APORT1YCH5]<br><br>BUSDX [ADC0:<br>APORT4XCH5<br>ACMP0:<br>APORT4XCH5<br>ACMP1:<br>APORT4XCH5] | TIM0_CC0 #21<br>TIM0_CC1 #20<br>TIM0_CC2 #19<br>TIM0_CDTI0 #18<br>TIM0_CDTI1 #17<br>TIM0_CDTI2 #16<br>TIM1_CC0 #21<br>TIM1_CC1 #20<br>TIM1_CC2 #19<br>TIM1_CC3 #18 LE-<br>TIM0_OUT0 #21<br>LETIM0_OUT1 #20<br>PCNT0_S0IN #21<br>PCNT0_S1IN #20 | US0_TX #21<br>US0_RX #20<br>US0_CLK #19<br>US0_CS #18<br>US0_CTS #17<br>US0_RTS #16<br>US1_TX #21<br>US1_RX #20<br>US1_CLK #19<br>US1_CS #18<br>US1_CTS #17<br>US1_RTS #16<br>LEU0_TX #21<br>LEU0_RX #20<br>I2C0_SDA #21<br>I2C0_SCL #20 | FRC_DCLK #21<br>FRC_DOUT #20<br>FRC_DFRAME #19<br>MODEM_DCLK #21<br>MODEM_DIN #20<br>MODEM_DOUT #19<br>MODEM_ANT0 #18<br>MODEM_ANT1 #17 | PRS_CH3 #12<br>PRS_CH4 #4<br>PRS_CH5 #3<br>PRS_CH6 #15<br>ACMP0_O #21<br>ACMP1_O #21                               |
| 23                  | PD14     | BUSCX [ADC0:<br>APORT3XCH6<br>ACMP0:<br>APORT3XCH6<br>ACMP1:<br>APORT3XCH6<br>IDAC0:<br>APORT1XCH6]<br><br>BUSDY [ADC0:<br>APORT4YCH6<br>ACMP0:<br>APORT4YCH6<br>ACMP1:<br>APORT4YCH6] | TIM0_CC0 #22<br>TIM0_CC1 #21<br>TIM0_CC2 #20<br>TIM0_CDTI0 #19<br>TIM0_CDTI1 #18<br>TIM0_CDTI2 #17<br>TIM1_CC0 #22<br>TIM1_CC1 #21<br>TIM1_CC2 #20<br>TIM1_CC3 #19 LE-<br>TIM0_OUT0 #22<br>LETIM0_OUT1 #21<br>PCNT0_S0IN #22<br>PCNT0_S1IN #21 | US0_TX #22<br>US0_RX #21<br>US0_CLK #20<br>US0_CS #19<br>US0_CTS #18<br>US0_RTS #17<br>US1_TX #22<br>US1_RX #21<br>US1_CLK #20<br>US1_CS #19<br>US1_CTS #18<br>US1_RTS #17<br>LEU0_TX #22<br>LEU0_RX #21<br>I2C0_SDA #22<br>I2C0_SCL #21 | FRC_DCLK #22<br>FRC_DOUT #21<br>FRC_DFRAME #20<br>MODEM_DCLK #22<br>MODEM_DIN #21<br>MODEM_DOUT #20<br>MODEM_ANT0 #19<br>MODEM_ANT1 #18 | CMU_CLK0 #5<br>PRS_CH3 #13<br>PRS_CH4 #5<br>PRS_CH5 #4<br>PRS_CH6 #16<br>ACMP0_O #22<br>ACMP1_O #22<br>GPIO_EM4WU4 |
| 24                  | PD15     | BUSCY [ADC0:<br>APORT3YCH7<br>ACMP0:<br>APORT3YCH7<br>ACMP1:<br>APORT3YCH7<br>IDAC0:<br>APORT1YCH7]<br><br>BUSDX [ADC0:<br>APORT4XCH7<br>ACMP0:<br>APORT4XCH7<br>ACMP1:<br>APORT4XCH7] | TIM0_CC0 #23<br>TIM0_CC1 #22<br>TIM0_CC2 #21<br>TIM0_CDTI0 #20<br>TIM0_CDTI1 #19<br>TIM0_CDTI2 #18<br>TIM1_CC0 #23<br>TIM1_CC1 #22<br>TIM1_CC2 #21<br>TIM1_CC3 #20 LE-<br>TIM0_OUT0 #23<br>LETIM0_OUT1 #22<br>PCNT0_S0IN #23<br>PCNT0_S1IN #22 | US0_TX #23<br>US0_RX #22<br>US0_CLK #21<br>US0_CS #20<br>US0_CTS #19<br>US0_RTS #18<br>US1_TX #23<br>US1_RX #22<br>US1_CLK #21<br>US1_CS #20<br>US1_CTS #19<br>US1_RTS #18<br>LEU0_TX #23<br>LEU0_RX #22<br>I2C0_SDA #23<br>I2C0_SCL #22 | FRC_DCLK #23<br>FRC_DOUT #22<br>FRC_DFRAME #21<br>MODEM_DCLK #23<br>MODEM_DIN #22<br>MODEM_DOUT #21<br>MODEM_ANT0 #20<br>MODEM_ANT1 #19 | CMU_CLK1 #5<br>PRS_CH3 #14<br>PRS_CH4 #6<br>PRS_CH5 #5<br>PRS_CH6 #17<br>ACMP0_O #23<br>ACMP1_O #23<br>DBG_SWO #2  |

| QFN48 Pin# and Name |          | Pin Alternate Functionality / Description   |  |  |   |  |
|---------------------|----------|---|--|--|---|--|
| Pin #               | Pin Name | Analog  | Timers   | Communication  | Radio   | Other  |
| 25                  | PA0      | ADC0_EXTN<br><br>BUSCX [ADC0:<br>APORT3XCH8<br>ACMP0:<br>APORT3XCH8<br>ACMP1:<br>APORT3XCH8<br>IDAC0:<br>APORT1XCH8]<br><br>BUSDY [ADC0:<br>APORT4YCH8<br>ACMP0:<br>APORT4YCH8<br>ACMP1:<br>APORT4YCH8] | TIM0_CC0 #0<br>TIM0_CC1 #31<br>TIM0_CC2 #30<br>TIM0_CDTI0 #29<br>TIM0_CDTI1 #28<br>TIM0_CDTI2 #27<br>TIM1_CC0 #0<br>TIM1_CC1 #31<br>TIM1_CC2 #30<br>TIM1_CC3 #29 LE-<br>TIM0_OUT0 #0 LE-<br>TIM0_OUT1 #31<br>PCNT0_S0IN #0<br>PCNT0_S1IN #31 | US0_TX #0<br>US0_RX #31<br>US0_CLK #30<br>US0_CS #29<br>US0_CTS #28<br>US0_RTS #27<br>US1_TX #0<br>US1_RX #31<br>US1_CLK #30<br>US1_CS #29<br>US1_CTS #28<br>US1_RTS #27<br>LEU0_TX #0<br>LEU0_RX #31<br>I2C0_SDA #0<br>I2C0_SCL #31 | FRC_DCLK #0<br>FRC_DOUT #31<br>FRC_DFRAME #30<br>MODEM_DCLK #0<br>MODEM_DIN #31<br>MODEM_DOUT #30<br>MODEM_ANT0 #29<br>MODEM_ANT1 #28 | CMU_CLK1 #0<br>PRS_CH6 #0<br>PRS_CH7 #10<br>PRS_CH8 #9<br>PRS_CH9 #8<br>ACMP0_O #0<br>ACMP1_O #0 |
| 26                  | PA1      | ADC0_EXTP<br><br>BUSCY [ADC0:<br>APORT3YCH9<br>ACMP0:<br>APORT3YCH9<br>ACMP1:<br>APORT3YCH9<br>IDAC0:<br>APORT1YCH9]<br><br>BUSDX [ADC0:<br>APORT4XCH9<br>ACMP0:<br>APORT4XCH9<br>ACMP1:<br>APORT4XCH9] | TIM0_CC0 #1<br>TIM0_CC1 #0<br>TIM0_CC2 #31<br>TIM0_CDTI0 #30<br>TIM0_CDTI1 #29<br>TIM0_CDTI2 #28<br>TIM1_CC0 #1<br>TIM1_CC1 #0<br>TIM1_CC2 #31<br>TIM1_CC3 #30 LE-<br>TIM0_OUT0 #1 LE-<br>TIM0_OUT1 #0<br>PCNT0_S0IN #1<br>PCNT0_S1IN #0     | US0_TX #1<br>US0_RX #0<br>US0_CLK #31<br>US0_CS #30<br>US0_CTS #29<br>US0_RTS #28<br>US1_TX #1<br>US1_RX #0<br>US1_CLK #31<br>US1_CS #30<br>US1_CTS #29<br>US1_RTS #28<br>LEU0_TX #1<br>LEU0_RX #0<br>I2C0_SDA #1<br>I2C0_SCL #0     | FRC_DCLK #1<br>FRC_DOUT #0<br>FRC_DFRAME #31<br>MODEM_DCLK #1<br>MODEM_DIN #0<br>MODEM_DOUT #31<br>MODEM_ANT0 #30<br>MODEM_ANT1 #29   | CMU_CLK0 #0<br>PRS_CH6 #1<br>PRS_CH7 #0<br>PRS_CH8 #10<br>PRS_CH9 #9<br>ACMP0_O #1<br>ACMP1_O #1 |
| 27                  | PA2      | BUSCX [ADC0:<br>APORT3XCH10<br>ACMP0:<br>APORT3XCH10<br>ACMP1:<br>APORT3XCH10<br>IDAC0:<br>APORT1XCH10]<br><br>BUSDY [ADC0:<br>APORT4YCH10<br>ACMP0:<br>APORT4YCH10<br>ACMP1:<br>APORT4YCH10]           | TIM0_CC0 #2<br>TIM0_CC1 #1<br>TIM0_CC2 #0<br>TIM0_CDTI0 #31<br>TIM0_CDTI1 #30<br>TIM0_CDTI2 #29<br>TIM1_CC0 #2<br>TIM1_CC1 #1<br>TIM1_CC2 #0<br>TIM1_CC3 #31 LE-<br>TIM0_OUT0 #2 LE-<br>TIM0_OUT1 #1<br>PCNT0_S0IN #2<br>PCNT0_S1IN #1       | US0_TX #2<br>US0_RX #1<br>US0_CLK #0<br>US0_CS #31<br>US0_CTS #30<br>US0_RTS #29<br>US1_TX #2<br>US1_RX #1<br>US1_CLK #0<br>US1_CS #31<br>US1_CTS #30<br>US1_RTS #29<br>LEU0_TX #2<br>LEU0_RX #1<br>I2C0_SDA #2<br>I2C0_SCL #1       | FRC_DCLK #2<br>FRC_DOUT #1<br>FRC_DFRAME #0<br>MODEM_DCLK #2<br>MODEM_DIN #1<br>MODEM_DOUT #0<br>MODEM_ANT0 #31<br>MODEM_ANT1 #30     | PRS_CH6 #2<br>PRS_CH7 #1<br>PRS_CH8 #0<br>PRS_CH9 #10<br>ACMP0_O #2<br>ACMP1_O #2                |



| QFN48 Pin# and Name |          | Pin Alternate Functionality / Description  |  |  |  |  |
|---------------------|----------|--|--|--|--|--|
| Pin #               | Pin Name | Analog   | Timers   | Communication  | Radio  | Other  |
| 28                  | PA3      | <p>BUSCY [ADC0:<br/>APORT3YCH11<br/>ACMP0:<br/>APORT3YCH11<br/>ACMP1:<br/>APORT3YCH11<br/>IDAC0:<br/>APORT1YCH11]</p> <p>BUSDX [ADC0:<br/>APORT4XCH11<br/>ACMP0:<br/>APORT4XCH11<br/>ACMP1:<br/>APORT4XCH11]</p> | <p>TIM0_CC0 #3<br/>TIM0_CC1 #2<br/>TIM0_CC2 #1<br/>TIM0_CDTI0 #0<br/>TIM0_CDTI1 #31<br/>TIM0_CDTI2 #30<br/>TIM1_CC0 #3<br/>TIM1_CC1 #2<br/>TIM1_CC2 #1<br/>TIM1_CC3 #0 LE-<br/>TIM0_OUT0 #3 LE-<br/>TIM0_OUT1 #2<br/>PCNT0_S0IN #3<br/>PCNT0_S1IN #2</p> | <p>US0_TX #3<br/>US0_RX #2<br/>US0_CLK #1<br/>US0_CS #0<br/>US0_CTS #31<br/>US0_RTS #30<br/>US1_TX #3<br/>US1_RX #2<br/>US1_CLK #1<br/>US1_CS #0<br/>US1_CTS #31<br/>US1_RTS #30<br/>LEU0_TX #3<br/>LEU0_RX #2<br/>I2C0_SDA #3<br/>I2C0_SCL #2</p> | <p>FRC_DCLK #3<br/>FRC_DOUT #2<br/>FRC_DFRAME #1<br/>MODEM_DCLK #3<br/>MODEM_DIN #2<br/>MODEM_DOUT #1<br/>MODEM_ANT0 #0<br/>MODEM_ANT1 #31</p> | <p>PRS_CH6 #3<br/>PRS_CH7 #2<br/>PRS_CH8 #1<br/>PRS_CH9 #0<br/>ACMP0_O #3<br/>ACMP1_O #3<br/>GPIO_EM4WU8</p> |
| 29                  | PA4      | <p>BUSCX [ADC0:<br/>APORT3XCH12<br/>ACMP0:<br/>APORT3XCH12<br/>ACMP1:<br/>APORT3XCH12<br/>IDAC0:<br/>APORT1XCH12]</p> <p>BUSDY [ADC0:<br/>APORT4YCH12<br/>ACMP0:<br/>APORT4YCH12<br/>ACMP1:<br/>APORT4YCH12]</p> | <p>TIM0_CC0 #4<br/>TIM0_CC1 #3<br/>TIM0_CC2 #2<br/>TIM0_CDTI0 #1<br/>TIM0_CDTI1 #0<br/>TIM0_CDTI2 #31<br/>TIM1_CC0 #4<br/>TIM1_CC1 #3<br/>TIM1_CC2 #2<br/>TIM1_CC3 #1 LE-<br/>TIM0_OUT0 #4 LE-<br/>TIM0_OUT1 #3<br/>PCNT0_S0IN #4<br/>PCNT0_S1IN #3</p>  | <p>US0_TX #4<br/>US0_RX #3<br/>US0_CLK #2<br/>US0_CS #1<br/>US0_CTS #0<br/>US0_RTS #31<br/>US1_TX #4<br/>US1_RX #3<br/>US1_CLK #2<br/>US1_CS #1<br/>US1_CTS #0<br/>US1_RTS #31<br/>LEU0_TX #4<br/>LEU0_RX #3<br/>I2C0_SDA #4<br/>I2C0_SCL #3</p>   | <p>FRC_DCLK #4<br/>FRC_DOUT #3<br/>FRC_DFRAME #2<br/>MODEM_DCLK #4<br/>MODEM_DIN #3<br/>MODEM_DOUT #2<br/>MODEM_ANT0 #1<br/>MODEM_ANT1 #0</p>  | <p>PRS_CH6 #4<br/>PRS_CH7 #3<br/>PRS_CH8 #2<br/>PRS_CH9 #1<br/>ACMP0_O #4<br/>ACMP1_O #4</p>                 |
| 30                  | PA5      | <p>BUSCY [ADC0:<br/>APORT3YCH13<br/>ACMP0:<br/>APORT3YCH13<br/>ACMP1:<br/>APORT3YCH13<br/>IDAC0:<br/>APORT1YCH13]</p> <p>BUSDX [ADC0:<br/>APORT4XCH13<br/>ACMP0:<br/>APORT4XCH13<br/>ACMP1:<br/>APORT4XCH13]</p> | <p>TIM0_CC0 #5<br/>TIM0_CC1 #4<br/>TIM0_CC2 #3<br/>TIM0_CDTI0 #2<br/>TIM0_CDTI1 #1<br/>TIM0_CDTI2 #0<br/>TIM1_CC0 #5<br/>TIM1_CC1 #4<br/>TIM1_CC2 #3<br/>TIM1_CC3 #2 LE-<br/>TIM0_OUT0 #5 LE-<br/>TIM0_OUT1 #4<br/>PCNT0_S0IN #5<br/>PCNT0_S1IN #4</p>   | <p>US0_TX #5<br/>US0_RX #4<br/>US0_CLK #3<br/>US0_CS #2<br/>US0_CTS #1<br/>US0_RTS #0<br/>US1_TX #5<br/>US1_RX #4<br/>US1_CLK #3<br/>US1_CS #2<br/>US1_CTS #1<br/>US1_RTS #0<br/>LEU0_TX #5<br/>LEU0_RX #4<br/>I2C0_SDA #5<br/>I2C0_SCL #4</p>     | <p>FRC_DCLK #5<br/>FRC_DOUT #4<br/>FRC_DFRAME #3<br/>MODEM_DCLK #5<br/>MODEM_DIN #4<br/>MODEM_DOUT #3<br/>MODEM_ANT0 #2<br/>MODEM_ANT1 #1</p>  | <p>PRS_CH6 #5<br/>PRS_CH7 #4<br/>PRS_CH8 #3<br/>PRS_CH9 #2<br/>ACMP0_O #5<br/>ACMP1_O #5</p>                 |

| QFN48 Pin# and Name |          | Pin Alternate Functionality / Description   |  |  |   |   |
|---------------------|----------|---|--|--|---|---|
| Pin #               | Pin Name | Analog  | Timers   | Communication  | Radio   | Other   |
| 31                  | PB11     | BUSCY [ADC0:<br>APORT3YCH27<br>ACMP0:<br>APORT3YCH27<br>ACMP1:<br>APORT3YCH27<br>IDAC0:<br>APORT1YCH27]<br><br>BUSDX [ADC0:<br>APORT4XCH27<br>ACMP0:<br>APORT4XCH27<br>ACMP1:<br>APORT4XCH27] | TIM0_CC0 #6<br>TIM0_CC1 #5<br>TIM0_CC2 #4<br>TIM0_CDTI0 #3<br>TIM0_CDTI1 #2<br>TIM0_CDTI2 #1<br>TIM1_CC0 #6<br>TIM1_CC1 #5<br>TIM1_CC2 #4<br>TIM1_CC3 #3 LE-<br>TIM0_OUT0 #6 LE-<br>TIM0_OUT1 #5<br>PCNT0_S0IN #6<br>PCNT0_S1IN #5 | US0_TX #6<br>US0_RX #5<br>US0_CLK #4<br>US0_CS #3<br>US0_CTS #2<br>US0_RTS #1<br>US1_TX #6<br>US1_RX #5<br>US1_CLK #4<br>US1_CS #3<br>US1_CTS #2<br>US1_RTS #1<br>LEU0_TX #6<br>LEU0_RX #5<br>I2C0_SDA #6<br>I2C0_SCL #5 | FRC_DCLK #6<br>FRC_DOUT #5<br>FRC_DFRAME #4<br>MODEM_DCLK #6<br>MODEM_DIN #5<br>MODEM_DOUT #4<br>MODEM_ANT0 #3<br>MODEM_ANT1 #2 | PRS_CH6 #6<br>PRS_CH7 #5<br>PRS_CH8 #4<br>PRS_CH9 #3<br>ACMP0_O #6<br>ACMP1_O #6                              |
| 32                  | PB12     | BUSCX [ADC0:<br>APORT3XCH28<br>ACMP0:<br>APORT3XCH28<br>ACMP1:<br>APORT3XCH28<br>IDAC0:<br>APORT1XCH28]<br><br>BUSDY [ADC0:<br>APORT4YCH28<br>ACMP0:<br>APORT4YCH28<br>ACMP1:<br>APORT4YCH28] | TIM0_CC0 #7<br>TIM0_CC1 #6<br>TIM0_CC2 #5<br>TIM0_CDTI0 #4<br>TIM0_CDTI1 #3<br>TIM0_CDTI2 #2<br>TIM1_CC0 #7<br>TIM1_CC1 #6<br>TIM1_CC2 #5<br>TIM1_CC3 #4 LE-<br>TIM0_OUT0 #7 LE-<br>TIM0_OUT1 #6<br>PCNT0_S0IN #7<br>PCNT0_S1IN #6 | US0_TX #7<br>US0_RX #6<br>US0_CLK #5<br>US0_CS #4<br>US0_CTS #3<br>US0_RTS #2<br>US1_TX #7<br>US1_RX #6<br>US1_CLK #5<br>US1_CS #4<br>US1_CTS #3<br>US1_RTS #2<br>LEU0_TX #7<br>LEU0_RX #6<br>I2C0_SDA #7<br>I2C0_SCL #6 | FRC_DCLK #7<br>FRC_DOUT #6<br>FRC_DFRAME #5<br>MODEM_DCLK #7<br>MODEM_DIN #6<br>MODEM_DOUT #5<br>MODEM_ANT0 #4<br>MODEM_ANT1 #3 | PRS_CH6 #7<br>PRS_CH7 #6<br>PRS_CH8 #5<br>PRS_CH9 #4<br>ACMP0_O #7<br>ACMP1_O #7                              |
| 33                  | PB13     | BUSCY [ADC0:<br>APORT3YCH29<br>ACMP0:<br>APORT3YCH29<br>ACMP1:<br>APORT3YCH29<br>IDAC0:<br>APORT1YCH29]<br><br>BUSDX [ADC0:<br>APORT4XCH29<br>ACMP0:<br>APORT4XCH29<br>ACMP1:<br>APORT4XCH29] | TIM0_CC0 #8<br>TIM0_CC1 #7<br>TIM0_CC2 #6<br>TIM0_CDTI0 #5<br>TIM0_CDTI1 #4<br>TIM0_CDTI2 #3<br>TIM1_CC0 #8<br>TIM1_CC1 #7<br>TIM1_CC2 #6<br>TIM1_CC3 #5 LE-<br>TIM0_OUT0 #8 LE-<br>TIM0_OUT1 #7<br>PCNT0_S0IN #8<br>PCNT0_S1IN #7 | US0_TX #8<br>US0_RX #7<br>US0_CLK #6<br>US0_CS #5<br>US0_CTS #4<br>US0_RTS #3<br>US1_TX #8<br>US1_RX #7<br>US1_CLK #6<br>US1_CS #5<br>US1_CTS #4<br>US1_RTS #3<br>LEU0_TX #8<br>LEU0_RX #7<br>I2C0_SDA #8<br>I2C0_SCL #7 | FRC_DCLK #8<br>FRC_DOUT #7<br>FRC_DFRAME #6<br>MODEM_DCLK #8<br>MODEM_DIN #7<br>MODEM_DOUT #6<br>MODEM_ANT0 #5<br>MODEM_ANT1 #4 | PRS_CH6 #8<br>PRS_CH7 #7<br>PRS_CH8 #6<br>PRS_CH9 #5<br>ACMP0_O #8<br>ACMP1_O #8<br>DBG_SWO #1<br>GPIO_EM4WU9 |
| 34                  | AVDD     | Analog power supply.  |  |  |   |   |

| QFN48 Pin# and Name |          | Pin Alternate Functionality / Description   |  |  |   |  |
|---------------------|----------|---|--|--|---|--|
| Pin #               | Pin Name | Analog  | Timers   | Communication  | Radio   | Other  |
| 35                  | PB14     | LFX TAL_N<br><br>BUSCX [ADC0:<br>APOR T3XCH30<br>ACMP0:<br>APOR T3XCH30<br>ACMP1:<br>APOR T3XCH30<br>IDAC0:<br>APOR T1XCH30]<br><br>BUSDY [ADC0:<br>APOR T4YCH30<br>ACMP0:<br>APOR T4YCH30<br>ACMP1:<br>APOR T4YCH30] | TIM0_CC0 #9<br>TIM0_CC1 #8<br>TIM0_CC2 #7<br>TIM0_CDT10 #6<br>TIM0_CDT11 #5<br>TIM0_CDT12 #4<br>TIM1_CC0 #9<br>TIM1_CC1 #8<br>TIM1_CC2 #7<br>TIM1_CC3 #6 LE-<br>TIM0_OUT0 #9 LE-<br>TIM0_OUT1 #8<br>PCNT0_S0IN #9<br>PCNT0_S1IN #8   | US0_TX #9<br>US0_RX #8<br>US0_CLK #7<br>US0_CS #6<br>US0_CTS #5<br>US0_RTS #4<br>US1_TX #9<br>US1_RX #8<br>US1_CLK #7<br>US1_CS #6<br>US1_CTS #5<br>US1_RTS #4<br>LEU0_TX #9<br>LEU0_RX #8<br>I2C0_SDA #9<br>I2C0_SCL #8     | FRC_DCLK #9<br>FRC_DOUT #8<br>FRC_DFRAME #7<br>MODEM_DCLK #9<br>MODEM_DIN #8<br>MODEM_DOUT #7<br>MODEM_ANT0 #6<br>MODEM_ANT1 #5   | CMU_CLK1 #1<br>PRS_CH6 #9<br>PRS_CH7 #8<br>PRS_CH8 #7<br>PRS_CH9 #6<br>ACMP0_O #9<br>ACMP1_O #9    |
| 36                  | PB15     | LFX TAL_P<br><br>BUSCY [ADC0:<br>APOR T3YCH31<br>ACMP0:<br>APOR T3YCH31<br>ACMP1:<br>APOR T3YCH31<br>IDAC0:<br>APOR T1YCH31]<br><br>BUSDX [ADC0:<br>APOR T4XCH31<br>ACMP0:<br>APOR T4XCH31<br>ACMP1:<br>APOR T4XCH31] | TIM0_CC0 #10<br>TIM0_CC1 #9<br>TIM0_CC2 #8<br>TIM0_CDT10 #7<br>TIM0_CDT11 #6<br>TIM0_CDT12 #5<br>TIM1_CC0 #10<br>TIM1_CC1 #9<br>TIM1_CC2 #8<br>TIM1_CC3 #7 LE-<br>TIM0_OUT0 #10<br>LETIM0_OUT1 #9<br>PCNT0_S0IN #10<br>PCNT0_S1IN #9 | US0_TX #10<br>US0_RX #9<br>US0_CLK #8<br>US0_CS #7<br>US0_CTS #6<br>US0_RTS #5<br>US1_TX #10<br>US1_RX #9<br>US1_CLK #8<br>US1_CS #7<br>US1_CTS #6<br>US1_RTS #5<br>LEU0_TX #10<br>LEU0_RX #9<br>I2C0_SDA #10<br>I2C0_SCL #9 | FRC_DCLK #10<br>FRC_DOUT #9<br>FRC_DFRAME #8<br>MODEM_DCLK #10<br>MODEM_DIN #9<br>MODEM_DOUT #8<br>MODEM_ANT0 #7<br>MODEM_ANT1 #6 | CMU_CLK0 #1<br>PRS_CH6 #10<br>PRS_CH7 #9<br>PRS_CH8 #8<br>PRS_CH9 #7<br>ACMP0_O #10<br>ACMP1_O #10 |
| 37                  | VREGVSS  | Voltage regulator VSS   |  |  |   |  |
| 38                  | VREGSW   | DCDC regulator switching node   |  |  |   |  |
| 39                  | VREGVDD  | Voltage regulator VDD input   |  |  |   |  |
| 40                  | DVDD     | Digital power supply.   |  |  |   |  |
| 41                  | DECOUPLE | Decouple output for on-chip voltage regulator. An external decoupling capacitor is required at this pin.  |  |  |   |  |
| 42                  | IOVDD    | Digital IO power supply.  |  |  |   |  |

| QFN48 Pin# and Name |          | Pin Alternate Functionality / Description  |  |  |  |  |
|---------------------|----------|--|--|--|--|--|
| Pin #               | Pin Name | Analog   | Timers   | Communication  | Radio  | Other  |
| 43                  | PC6      | BUSAX [ADC0:<br>APORT1XCH6<br>ACMP0:<br>APORT1XCH6<br>ACMP1:<br>APORT1XCH6]<br><br>BUSBY [ADC0:<br>APORT2YCH6<br>ACMP0:<br>APORT2YCH6<br>ACMP1:<br>APORT2YCH6] | TIM0_CC0 #11<br>TIM0_CC1 #10<br>TIM0_CC2 #9<br>TIM0_CDTI0 #8<br>TIM0_CDTI1 #7<br>TIM0_CDTI2 #6<br>TIM1_CC0 #11<br>TIM1_CC1 #10<br>TIM1_CC2 #9<br>TIM1_CC3 #8 LE-<br>TIM0_OUT0 #11<br>LETIM0_OUT1 #10<br>PCNT0_S0IN #11<br>PCNT0_S1IN #10     | US0_TX #11<br>US0_RX #10<br>US0_CLK #9<br>US0_CS #8<br>US0_CTS #7<br>US0_RTS #6<br>US1_TX #11<br>US1_RX #10<br>US1_CLK #9<br>US1_CS #8<br>US1_CTS #7<br>US1_RTS #6<br>LEU0_TX #11<br>LEU0_RX #10<br>I2C0_SDA #11<br>I2C0_SCL #10     | FRC_DCLK #11<br>FRC_DOUT #10<br>FRC_DFRAME #9<br>MODEM_DCLK #11<br>MODEM_DIN #10<br>MODEM_DOUT #9<br>MODEM_ANT0 #8<br>MODEM_ANT1 #7    | CMU_CLK0 #2<br>PRS_CH0 #8<br>PRS_CH9 #11<br>PRS_CH10 #0<br>PRS_CH11 #5<br>ACMP0_O #11<br>ACMP1_O #11 |
| 44                  | PC7      | BUSAY [ADC0:<br>APORT1YCH7<br>ACMP0:<br>APORT1YCH7<br>ACMP1:<br>APORT1YCH7]<br><br>BUSBX [ADC0:<br>APORT2XCH7<br>ACMP0:<br>APORT2XCH7<br>ACMP1:<br>APORT2XCH7] | TIM0_CC0 #12<br>TIM0_CC1 #11<br>TIM0_CC2 #10<br>TIM0_CDTI0 #9<br>TIM0_CDTI1 #8<br>TIM0_CDTI2 #7<br>TIM1_CC0 #12<br>TIM1_CC1 #11<br>TIM1_CC2 #10<br>TIM1_CC3 #9 LE-<br>TIM0_OUT0 #12<br>LETIM0_OUT1 #11<br>PCNT0_S0IN #12<br>PCNT0_S1IN #11   | US0_TX #12<br>US0_RX #11<br>US0_CLK #10<br>US0_CS #9<br>US0_CTS #8<br>US0_RTS #7<br>US1_TX #12<br>US1_RX #11<br>US1_CLK #10<br>US1_CS #9<br>US1_CTS #8<br>US1_RTS #7<br>LEU0_TX #12<br>LEU0_RX #11<br>I2C0_SDA #12<br>I2C0_SCL #11   | FRC_DCLK #12<br>FRC_DOUT #11<br>FRC_DFRAME #10<br>MODEM_DCLK #12<br>MODEM_DIN #11<br>MODEM_DOUT #10<br>MODEM_ANT0 #9<br>MODEM_ANT1 #8  | CMU_CLK1 #2<br>PRS_CH0 #9<br>PRS_CH9 #12<br>PRS_CH10 #1<br>PRS_CH11 #0<br>ACMP0_O #12<br>ACMP1_O #12 |
| 45                  | PC8      | BUSAX [ADC0:<br>APORT1XCH8<br>ACMP0:<br>APORT1XCH8<br>ACMP1:<br>APORT1XCH8]<br><br>BUSBY [ADC0:<br>APORT2YCH8<br>ACMP0:<br>APORT2YCH8<br>ACMP1:<br>APORT2YCH8] | TIM0_CC0 #13<br>TIM0_CC1 #12<br>TIM0_CC2 #11<br>TIM0_CDTI0 #10<br>TIM0_CDTI1 #9<br>TIM0_CDTI2 #8<br>TIM1_CC0 #13<br>TIM1_CC1 #12<br>TIM1_CC2 #11<br>TIM1_CC3 #10 LE-<br>TIM0_OUT0 #13<br>LETIM0_OUT1 #12<br>PCNT0_S0IN #13<br>PCNT0_S1IN #12 | US0_TX #13<br>US0_RX #12<br>US0_CLK #11<br>US0_CS #10<br>US0_CTS #9<br>US0_RTS #8<br>US1_TX #13<br>US1_RX #12<br>US1_CLK #11<br>US1_CS #10<br>US1_CTS #9<br>US1_RTS #8<br>LEU0_TX #13<br>LEU0_RX #12<br>I2C0_SDA #13<br>I2C0_SCL #12 | FRC_DCLK #13<br>FRC_DOUT #12<br>FRC_DFRAME #11<br>MODEM_DCLK #13<br>MODEM_DIN #12<br>MODEM_DOUT #11<br>MODEM_ANT0 #10<br>MODEM_ANT1 #9 | PRS_CH0 #10<br>PRS_CH9 #13<br>PRS_CH10 #2<br>PRS_CH11 #1<br>ACMP0_O #13<br>ACMP1_O #13               |

| QFN48 Pin# and Name |          | Pin Alternate Functionality / Description  |  |  |   |   |
|---------------------|----------|--|--|--|---|---|
| Pin #               | Pin Name | Analog   | Timers   | Communication  | Radio   | Other   |
| 46                  | PC9      | BUSAY [ADC0:<br>APORT1YCH9<br>ACMP0:<br>APORT1YCH9<br>ACMP1:<br>APORT1YCH9]<br><br>BUSBX [ADC0:<br>APORT2XCH9<br>ACMP0:<br>APORT2XCH9<br>ACMP1:<br>APORT2XCH9]       | TIM0_CC0 #14<br>TIM0_CC1 #13<br>TIM0_CC2 #12<br>TIM0_CDTI0 #11<br>TIM0_CDTI1 #10<br>TIM0_CDTI2 #9<br>TIM1_CC0 #14<br>TIM1_CC1 #13<br>TIM1_CC2 #12<br>TIM1_CC3 #11 LE-<br>TIM0_OUT0 #14<br>LETIM0_OUT1 #13<br>PCNT0_S0IN #14<br>PCNT0_S1IN #13  | US0_TX #14<br>US0_RX #13<br>US0_CLK #12<br>US0_CS #11<br>US0_CTS #10<br>US0_RTS #9<br>US1_TX #14<br>US1_RX #13<br>US1_CLK #12<br>US1_CS #11<br>US1_CTS #10<br>US1_RTS #9<br>LEU0_TX #14<br>LEU0_RX #13<br>I2C0_SDA #14<br>I2C0_SCL #13   | FRC_DCLK #14<br>FRC_DOUT #13<br>FRC_DFRAME #12<br>MODEM_DCLK #14<br>MODEM_DIN #13<br>MODEM_DOUT #12<br>MODEM_ANT0 #11<br>MODEM_ANT1 #10 | PRS_CH0 #11<br>PRS_CH9 #14<br>PRS_CH10 #3<br>PRS_CH11 #2<br>ACMP0_O #14<br>ACMP1_O #14                                |
| 47                  | PC10     | BUSAX [ADC0:<br>APORT1XCH10<br>ACMP0:<br>APORT1XCH10<br>ACMP1:<br>APORT1XCH10]<br><br>BUSBY [ADC0:<br>APORT2YCH10<br>ACMP0:<br>APORT2YCH10<br>ACMP1:<br>APORT2YCH10] | TIM0_CC0 #15<br>TIM0_CC1 #14<br>TIM0_CC2 #13<br>TIM0_CDTI0 #12<br>TIM0_CDTI1 #11<br>TIM0_CDTI2 #10<br>TIM1_CC0 #15<br>TIM1_CC1 #14<br>TIM1_CC2 #13<br>TIM1_CC3 #12 LE-<br>TIM0_OUT0 #15<br>LETIM0_OUT1 #14<br>PCNT0_S0IN #15<br>PCNT0_S1IN #14 | US0_TX #15<br>US0_RX #14<br>US0_CLK #13<br>US0_CS #12<br>US0_CTS #11<br>US0_RTS #10<br>US1_TX #15<br>US1_RX #14<br>US1_CLK #13<br>US1_CS #12<br>US1_CTS #11<br>US1_RTS #10<br>LEU0_TX #15<br>LEU0_RX #14<br>I2C0_SDA #15<br>I2C0_SCL #14 | FRC_DCLK #15<br>FRC_DOUT #14<br>FRC_DFRAME #13<br>MODEM_DCLK #15<br>MODEM_DIN #14<br>MODEM_DOUT #13<br>MODEM_ANT0 #12<br>MODEM_ANT1 #11 | CMU_CLK1 #3<br>PRS_CH0 #12<br>PRS_CH9 #15<br>PRS_CH10 #4<br>PRS_CH11 #3<br>ACMP0_O #15<br>ACMP1_O #15<br>GPIO_EM4WU12 |
| 48                  | PC11     | BUSAY [ADC0:<br>APORT1YCH11<br>ACMP0:<br>APORT1YCH11<br>ACMP1:<br>APORT1YCH11]<br><br>BUSBX [ADC0:<br>APORT2XCH11<br>ACMP0:<br>APORT2XCH11<br>ACMP1:<br>APORT2XCH11] | TIM0_CC0 #16<br>TIM0_CC1 #15<br>TIM0_CC2 #14<br>TIM0_CDTI0 #13<br>TIM0_CDTI1 #12<br>TIM0_CDTI2 #11<br>TIM1_CC0 #16<br>TIM1_CC1 #15<br>TIM1_CC2 #14<br>TIM1_CC3 #13 LE-<br>TIM0_OUT0 #16<br>LETIM0_OUT1 #15<br>PCNT0_S0IN #16<br>PCNT0_S1IN #15 | US0_TX #16<br>US0_RX #15<br>US0_CLK #14<br>US0_CS #13<br>US0_CTS #12<br>US0_RTS #11<br>US1_TX #16<br>US1_RX #15<br>US1_CLK #14<br>US1_CS #13<br>US1_CTS #12<br>US1_RTS #11<br>LEU0_TX #16<br>LEU0_RX #15<br>I2C0_SDA #16<br>I2C0_SCL #15 | FRC_DCLK #16<br>FRC_DOUT #15<br>FRC_DFRAME #14<br>MODEM_DCLK #16<br>MODEM_DIN #15<br>MODEM_DOUT #14<br>MODEM_ANT0 #13<br>MODEM_ANT1 #12 | CMU_CLK0 #3<br>PRS_CH0 #13<br>PRS_CH9 #16<br>PRS_CH10 #5<br>PRS_CH11 #4<br>ACMP0_O #16<br>ACMP1_O #16<br>DBG_SWO #3   |

### 6.3.1 EFR32FG1 QFN48 2.4 GHz and Sub-GHz GPIO Overview

The GPIO pins are organized as 16-bit ports indicated by letters A through F, and the individual pins on each port are indicated by a number from 15 down to 0.

**Table 6.6. QFN48 2.4 GHz and Sub-GHz GPIO Pinout**

| Port   | Pin 15    | Pin 14    | Pin 13    | Pin 12    | Pin 11    | Pin 10    | Pin 9    | Pin 8    | Pin 7    | Pin 6    | Pin 5    | Pin 4    | Pin 3    | Pin 2    | Pin 1    | Pin 0    |
|--------|-----------|-----------|-----------|-----------|-----------|-----------|----------|----------|----------|----------|----------|----------|----------|----------|----------|----------|
| Port A | -         | -         | -         | -         | -         | -         | -        | -        | -        | -        | PA5 (5V) | PA4 (5V) | PA3 (5V) | PA2 (5V) | PA1      | PA0      |
| Port B | PB15      | PB14      | PB13 (5V) | PB12 (5V) | PB11 (5V) | -         | -        | -        | -        | -        | -        | -        | -        | -        | -        | -        |
| Port C | -         | -         | -         | -         | PC11 (5V) | PC10 (5V) | PC9 (5V) | PC8 (5V) | PC7 (5V) | PC6 (5V) | -        | -        | -        | -        | -        | -        |
| Port D | PD15 (5V) | PD14 (5V) | PD13 (5V) | -         | -         | -         | -        | -        | -        | -        | -        | -        | -        | -        | -        | -        |
| Port F | -         | -         | -         | -         | -         | -         | -        | -        | PF7 (5V) | PF6 (5V) | PF5 (5V) | PF4 (5V) | PF3 (5V) | PF2 (5V) | PF1 (5V) | PF0 (5V) |

6.4 EFR32FG1 QFN32 Sub-GHz Definition

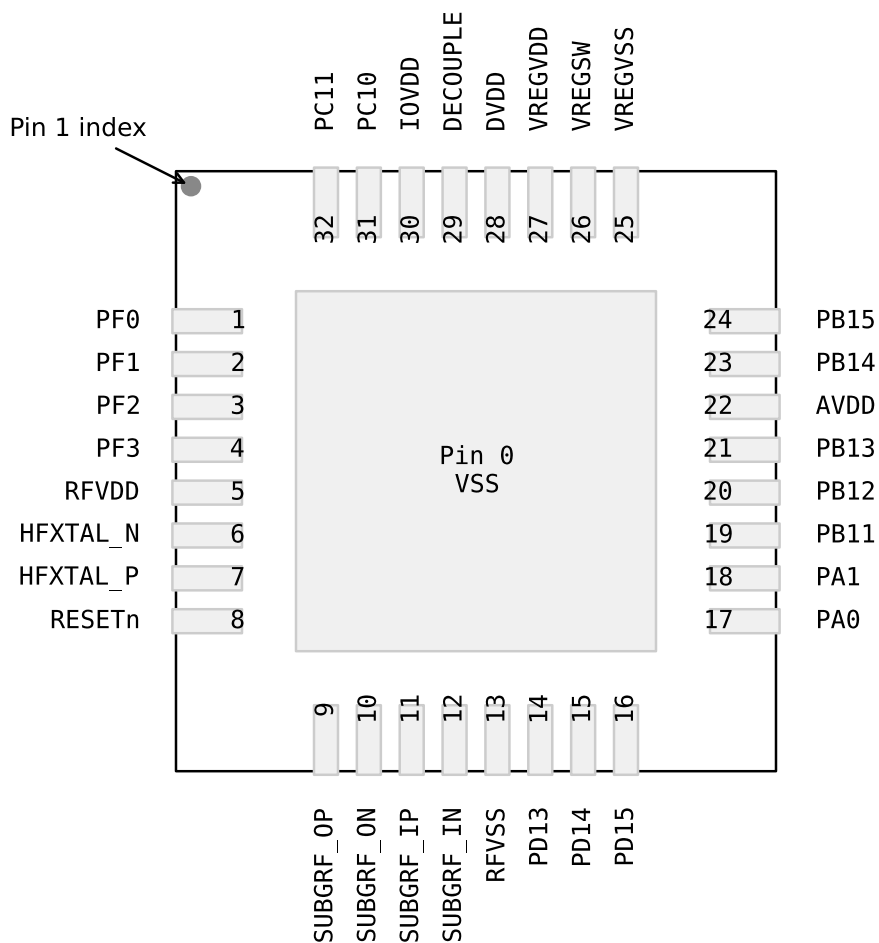


Figure 6.4. EFR32FG1 QFN32 Sub-GHz Pinout

Table 6.7. QFN32 Sub-GHz Device Pinout

| QFN32 Pin# and Name |          | Pin Alternate Functionality / Description  |  |  |   |  |
|---------------------|----------|--|--|--|---|--|
| Pin #               | Pin Name | Analog   | Timers   | Communication  | Radio   | Other  |
| 0                   | VSS      | Ground   |  |  |   |  |
| 1                   | PF0      | BUSAX [ADC0:<br>APORT1XCH16<br>ACMP0:<br>APORT1XCH16<br>ACMP1:<br>APORT1XCH16]<br><br>BUSBY [ADC0:<br>APORT2YCH16<br>ACMP0:<br>APORT2YCH16<br>ACMP1:<br>APORT2YCH16] | TIM0_CC0 #24<br>TIM0_CC1 #23<br>TIM0_CC2 #22<br>TIM0_CDTI0 #21<br>TIM0_CDTI1 #20<br>TIM0_CDTI2 #19<br>TIM1_CC0 #24<br>TIM1_CC1 #23<br>TIM1_CC2 #22<br>TIM1_CC3 #21 LE-<br>TIM0_OUT0 #24<br>LETIM0_OUT1 #23<br>PCNT0_S0IN #24<br>PCNT0_S1IN #23 | US0_TX #24<br>US0_RX #23<br>US0_CLK #22<br>US0_CS #21<br>US0_CTS #20<br>US0_RTS #19<br>US1_TX #24<br>US1_RX #23<br>US1_CLK #22<br>US1_CS #21<br>US1_CTS #20<br>US1_RTS #19<br>LEU0_TX #24<br>LEU0_RX #23<br>I2C0_SDA #24<br>I2C0_SCL #23 | FRC_DCLK #24<br>FRC_DOUT #23<br>FRC_DFRAME #22<br>MODEM_DCLK #24<br>MODEM_DIN #23<br>MODEM_DOUT #22<br>MODEM_ANT0 #21<br>MODEM_ANT1 #20 | PRS_CH0 #0<br>PRS_CH1 #7<br>PRS_CH2 #6<br>PRS_CH3 #5<br>ACMP0_O #24<br>ACMP1_O #24<br>DBG_SWCLKTCK #0  |
| 2                   | PF1      | BUSAY [ADC0:<br>APORT1YCH17<br>ACMP0:<br>APORT1YCH17<br>ACMP1:<br>APORT1YCH17]<br><br>BUSBX [ADC0:<br>APORT2XCH17<br>ACMP0:<br>APORT2XCH17<br>ACMP1:<br>APORT2XCH17] | TIM0_CC0 #25<br>TIM0_CC1 #24<br>TIM0_CC2 #23<br>TIM0_CDTI0 #22<br>TIM0_CDTI1 #21<br>TIM0_CDTI2 #20<br>TIM1_CC0 #25<br>TIM1_CC1 #24<br>TIM1_CC2 #23<br>TIM1_CC3 #22 LE-<br>TIM0_OUT0 #25<br>LETIM0_OUT1 #24<br>PCNT0_S0IN #25<br>PCNT0_S1IN #24 | US0_TX #25<br>US0_RX #24<br>US0_CLK #23<br>US0_CS #22<br>US0_CTS #21<br>US0_RTS #20<br>US1_TX #25<br>US1_RX #24<br>US1_CLK #23<br>US1_CS #22<br>US1_CTS #21<br>US1_RTS #20<br>LEU0_TX #25<br>LEU0_RX #24<br>I2C0_SDA #25<br>I2C0_SCL #24 | FRC_DCLK #25<br>FRC_DOUT #24<br>FRC_DFRAME #23<br>MODEM_DCLK #25<br>MODEM_DIN #24<br>MODEM_DOUT #23<br>MODEM_ANT0 #22<br>MODEM_ANT1 #21 | PRS_CH0 #1<br>PRS_CH1 #0<br>PRS_CH2 #7<br>PRS_CH3 #6<br>ACMP0_O #25<br>ACMP1_O #25<br>DBG_SWDIOTMS #0  |
| 3                   | PF2      | BUSAX [ADC0:<br>APORT1XCH18<br>ACMP0:<br>APORT1XCH18<br>ACMP1:<br>APORT1XCH18]<br><br>BUSBY [ADC0:<br>APORT2YCH18<br>ACMP0:<br>APORT2YCH18<br>ACMP1:<br>APORT2YCH18] | TIM0_CC0 #26<br>TIM0_CC1 #25<br>TIM0_CC2 #24<br>TIM0_CDTI0 #23<br>TIM0_CDTI1 #22<br>TIM0_CDTI2 #21<br>TIM1_CC0 #26<br>TIM1_CC1 #25<br>TIM1_CC2 #24<br>TIM1_CC3 #23 LE-<br>TIM0_OUT0 #26<br>LETIM0_OUT1 #25<br>PCNT0_S0IN #26<br>PCNT0_S1IN #25 | US0_TX #26<br>US0_RX #25<br>US0_CLK #24<br>US0_CS #23<br>US0_CTS #22<br>US0_RTS #21<br>US1_TX #26<br>US1_RX #25<br>US1_CLK #24<br>US1_CS #23<br>US1_CTS #22<br>US1_RTS #21<br>LEU0_TX #26<br>LEU0_RX #25<br>I2C0_SDA #26<br>I2C0_SCL #25 | FRC_DCLK #26<br>FRC_DOUT #25<br>FRC_DFRAME #24<br>MODEM_DCLK #26<br>MODEM_DIN #25<br>MODEM_DOUT #24<br>MODEM_ANT0 #23<br>MODEM_ANT1 #22 | CMU_CLK0 #6<br>PRS_CH0 #2<br>PRS_CH1 #1<br>PRS_CH2 #0<br>PRS_CH3 #7<br>ACMP0_O #26<br>ACMP1_O #26<br>DBG_TDO #0<br>DBG_SWO #0<br>GPIO_EM4WU0 |



| QFN32 Pin# and Name |           | Pin Alternate Functionality / Description   |  |  |   |   |
|---------------------|-----------|---|--|--|---|---|
| Pin #               | Pin Name  | Analog  | Timers   | Communication  | Radio   | Other   |
| 4                   | PF3       | BUSAY [ADC0: APORT1YCH19 ACMP0: APORT1YCH19 ACMP1: APORT1YCH19]<br><br>BUSBX [ADC0: APORT2XCH19 ACMP0: APORT2XCH19 ACMP1: APORT2XCH19]  | TIM0_CC0 #27<br>TIM0_CC1 #26<br>TIM0_CC2 #25<br>TIM0_CDTI0 #24<br>TIM0_CDTI1 #23<br>TIM0_CDTI2 #22<br>TIM1_CC0 #27<br>TIM1_CC1 #26<br>TIM1_CC2 #25<br>TIM1_CC3 #24 LE-<br>TIM0_OUT0 #27<br>LETIM0_OUT1 #26<br>PCNT0_S0IN #27<br>PCNT0_S1IN #26 | US0_TX #27<br>US0_RX #26<br>US0_CLK #25<br>US0_CS #24<br>US0_CTS #23<br>US0_RTS #22<br>US1_TX #27<br>US1_RX #26<br>US1_CLK #25<br>US1_CS #24<br>US1_CTS #23<br>US1_RTS #22<br>LEU0_TX #27<br>LEU0_RX #26<br>I2C0_SDA #27<br>I2C0_SCL #26 | FRC_DCLK #27<br>FRC_DOUT #26<br>FRC_DFRAME #25<br>MODEM_DCLK #27<br>MODEM_DIN #26<br>MODEM_DOUT #25<br>MODEM_ANT0 #24<br>MODEM_ANT1 #23 | CMU_CLK1 #6<br>PRS_CH0 #3<br>PRS_CH1 #2<br>PRS_CH2 #1<br>PRS_CH3 #0<br>ACMP0_O #27<br>ACMP1_O #27<br>DBG_TDI #0 |
| 5                   | RFVDD     | Radio power supply  |  |  |   |   |
| 6                   | HFXTAL_N  | High Frequency Crystal input pin.   |  |  |   |   |
| 7                   | HFXTAL_P  | High Frequency Crystal output pin.  |  |  |   |   |
| 8                   | RESETn    | Reset input, active low. To apply an external reset source to this pin, it is required to only drive this pin low during reset, and let the internal pull-up ensure that reset is released. |  |  |   |   |
| 9                   | SUBGRF_OP | Sub GHz Differential RF output, positive path.  |  |  |   |   |
| 10                  | SUBGRF_ON | Sub GHz Differential RF output, negative path.  |  |  |   |   |
| 11                  | SUBGRF_IP | Sub GHz Differential RF input, positive path.   |  |  |   |   |
| 12                  | SUBGRF_IN | Sub GHz Differential RF input, negative path.   |  |  |   |   |
| 13                  | RFVSS     | Radio Ground  |  |  |   |   |
| 14                  | PD13      | BUSCY [ADC0: APORT3YCH5 ACMP0: APORT3YCH5 ACMP1: APORT3YCH5 IDAC0: APORT1YCH5]<br><br>BUSDX [ADC0: APORT4XCH5 ACMP0: APORT4XCH5 ACMP1: APORT4XCH5]  | TIM0_CC0 #21<br>TIM0_CC1 #20<br>TIM0_CC2 #19<br>TIM0_CDTI0 #18<br>TIM0_CDTI1 #17<br>TIM0_CDTI2 #16<br>TIM1_CC0 #21<br>TIM1_CC1 #20<br>TIM1_CC2 #19<br>TIM1_CC3 #18 LE-<br>TIM0_OUT0 #21<br>LETIM0_OUT1 #20<br>PCNT0_S0IN #21<br>PCNT0_S1IN #20 | US0_TX #21<br>US0_RX #20<br>US0_CLK #19<br>US0_CS #18<br>US0_CTS #17<br>US0_RTS #16<br>US1_TX #21<br>US1_RX #20<br>US1_CLK #19<br>US1_CS #18<br>US1_CTS #17<br>US1_RTS #16<br>LEU0_TX #21<br>LEU0_RX #20<br>I2C0_SDA #21<br>I2C0_SCL #20 | FRC_DCLK #21<br>FRC_DOUT #20<br>FRC_DFRAME #19<br>MODEM_DCLK #21<br>MODEM_DIN #20<br>MODEM_DOUT #19<br>MODEM_ANT0 #18<br>MODEM_ANT1 #17 | PRS_CH3 #12<br>PRS_CH4 #4<br>PRS_CH5 #3<br>PRS_CH6 #15<br>ACMP0_O #21<br>ACMP1_O #21                            |

| QFN32 Pin# and Name |          | Pin Alternate Functionality / Description   |  |  |   |  |
|---------------------|----------|---|--|--|---|--|
| Pin #               | Pin Name | Analog  | Timers   | Communication  | Radio   | Other  |
| 15                  | PD14     | BUSCX [ADC0:<br>APORT3XCH6<br>ACMP0:<br>APORT3XCH6<br>ACMP1:<br>APORT3XCH6<br>IDAC0:<br>APORT1XCH6]<br><br>BUSDY [ADC0:<br>APORT4YCH6<br>ACMP0:<br>APORT4YCH6<br>ACMP1:<br>APORT4YCH6]                  | TIM0_CC0 #22<br>TIM0_CC1 #21<br>TIM0_CC2 #20<br>TIM0_CDTI0 #19<br>TIM0_CDTI1 #18<br>TIM0_CDTI2 #17<br>TIM1_CC0 #22<br>TIM1_CC1 #21<br>TIM1_CC2 #20<br>TIM1_CC3 #19 LE-<br>TIM0_OUT0 #22<br>LETIM0_OUT1 #21<br>PCNT0_S0IN #22<br>PCNT0_S1IN #21 | US0_TX #22<br>US0_RX #21<br>US0_CLK #20<br>US0_CS #19<br>US0_CTS #18<br>US0_RTS #17<br>US1_TX #22<br>US1_RX #21<br>US1_CLK #20<br>US1_CS #19<br>US1_CTS #18<br>US1_RTS #17<br>LEU0_TX #22<br>LEU0_RX #21<br>I2C0_SDA #22<br>I2C0_SCL #21 | FRC_DCLK #22<br>FRC_DOUT #21<br>FRC_DFRAME #20<br>MODEM_DCLK #22<br>MODEM_DIN #21<br>MODEM_DOUT #20<br>MODEM_ANT0 #19<br>MODEM_ANT1 #18 | CMU_CLK0 #5<br>PRS_CH3 #13<br>PRS_CH4 #5<br>PRS_CH5 #4<br>PRS_CH6 #16<br>ACMP0_O #22<br>ACMP1_O #22<br>GPIO_EM4WU4 |
| 16                  | PD15     | BUSCY [ADC0:<br>APORT3YCH7<br>ACMP0:<br>APORT3YCH7<br>ACMP1:<br>APORT3YCH7<br>IDAC0:<br>APORT1YCH7]<br><br>BUSDX [ADC0:<br>APORT4XCH7<br>ACMP0:<br>APORT4XCH7<br>ACMP1:<br>APORT4XCH7]                  | TIM0_CC0 #23<br>TIM0_CC1 #22<br>TIM0_CC2 #21<br>TIM0_CDTI0 #20<br>TIM0_CDTI1 #19<br>TIM0_CDTI2 #18<br>TIM1_CC0 #23<br>TIM1_CC1 #22<br>TIM1_CC2 #21<br>TIM1_CC3 #20 LE-<br>TIM0_OUT0 #23<br>LETIM0_OUT1 #22<br>PCNT0_S0IN #23<br>PCNT0_S1IN #22 | US0_TX #23<br>US0_RX #22<br>US0_CLK #21<br>US0_CS #20<br>US0_CTS #19<br>US0_RTS #18<br>US1_TX #23<br>US1_RX #22<br>US1_CLK #21<br>US1_CS #20<br>US1_CTS #19<br>US1_RTS #18<br>LEU0_TX #23<br>LEU0_RX #22<br>I2C0_SDA #23<br>I2C0_SCL #22 | FRC_DCLK #23<br>FRC_DOUT #22<br>FRC_DFRAME #21<br>MODEM_DCLK #23<br>MODEM_DIN #22<br>MODEM_DOUT #21<br>MODEM_ANT0 #20<br>MODEM_ANT1 #19 | CMU_CLK1 #5<br>PRS_CH3 #14<br>PRS_CH4 #6<br>PRS_CH5 #5<br>PRS_CH6 #17<br>ACMP0_O #23<br>ACMP1_O #23<br>DBG_SWO #2  |
| 17                  | PA0      | ADC0_EXTN<br><br>BUSCX [ADC0:<br>APORT3XCH8<br>ACMP0:<br>APORT3XCH8<br>ACMP1:<br>APORT3XCH8<br>IDAC0:<br>APORT1XCH8]<br><br>BUSDY [ADC0:<br>APORT4YCH8<br>ACMP0:<br>APORT4YCH8<br>ACMP1:<br>APORT4YCH8] | TIM0_CC0 #0<br>TIM0_CC1 #31<br>TIM0_CC2 #30<br>TIM0_CDTI0 #29<br>TIM0_CDTI1 #28<br>TIM0_CDTI2 #27<br>TIM1_CC0 #0<br>TIM1_CC1 #31<br>TIM1_CC2 #30<br>TIM1_CC3 #29 LE-<br>TIM0_OUT0 #0 LE-<br>TIM0_OUT1 #31<br>PCNT0_S0IN #0<br>PCNT0_S1IN #31   | US0_TX #0<br>US0_RX #31<br>US0_CLK #30<br>US0_CS #29<br>US0_CTS #28<br>US0_RTS #27<br>US1_TX #0<br>US1_RX #31<br>US1_CLK #30<br>US1_CS #29<br>US1_CTS #28<br>US1_RTS #27<br>LEU0_TX #0<br>LEU0_RX #31<br>I2C0_SDA #0<br>I2C0_SCL #31     | FRC_DCLK #0<br>FRC_DOUT #31<br>FRC_DFRAME #30<br>MODEM_DCLK #0<br>MODEM_DIN #31<br>MODEM_DOUT #30<br>MODEM_ANT0 #29<br>MODEM_ANT1 #28   | CMU_CLK1 #0<br>PRS_CH6 #0<br>PRS_CH7 #10<br>PRS_CH8 #9<br>PRS_CH9 #8<br>ACMP0_O #0<br>ACMP1_O #0                   |

| QFN32 Pin# and Name |          | Pin Alternate Functionality / Description   |  |  |   |  |
|---------------------|----------|---|--|--|---|--|
| Pin #               | Pin Name | Analog  | Timers   | Communication  | Radio   | Other  |
| 18                  | PA1      | ADC0_EXTP<br>BUSCY [ADC0:<br>APORT3YCH9<br>ACMP0:<br>APORT3YCH9<br>ACMP1:<br>APORT3YCH9<br>IDAC0:<br>APORT1YCH9]<br>BUSDX [ADC0:<br>APORT4XCH9<br>ACMP0:<br>APORT4XCH9<br>ACMP1:<br>APORT4XCH9] | TIM0_CC0 #1<br>TIM0_CC1 #0<br>TIM0_CC2 #31<br>TIM0_CDTI0 #30<br>TIM0_CDTI1 #29<br>TIM0_CDTI2 #28<br>TIM1_CC0 #1<br>TIM1_CC1 #0<br>TIM1_CC2 #31<br>TIM1_CC3 #30 LE-<br>TIM0_OUT0 #1 LE-<br>TIM0_OUT1 #0<br>PCNT0_S0IN #1<br>PCNT0_S1IN #0 | US0_TX #1<br>US0_RX #0<br>US0_CLK #31<br>US0_CS #30<br>US0_CTS #29<br>US0_RTS #28<br>US1_TX #1<br>US1_RX #0<br>US1_CLK #31<br>US1_CS #30<br>US1_CTS #29<br>US1_RTS #28<br>LEU0_TX #1<br>LEU0_RX #0<br>I2C0_SDA #1<br>I2C0_SCL #0 | FRC_DCLK #1<br>FRC_DOUT #0<br>FRC_DFRAME #31<br>MODEM_DCLK #1<br>MODEM_DIN #0<br>MODEM_DOUT #31<br>MODEM_ANT0 #30<br>MODEM_ANT1 #29 | CMU_CLK0 #0<br>PRS_CH6 #1<br>PRS_CH7 #0<br>PRS_CH8 #10<br>PRS_CH9 #9<br>ACMP0_O #1<br>ACMP1_O #1 |
| 19                  | PB11     | BUSCY [ADC0:<br>APORT3YCH27<br>ACMP0:<br>APORT3YCH27<br>ACMP1:<br>APORT3YCH27<br>IDAC0:<br>APORT1YCH27]<br>BUSDX [ADC0:<br>APORT4XCH27<br>ACMP0:<br>APORT4XCH27<br>ACMP1:<br>APORT4XCH27]       | TIM0_CC0 #6<br>TIM0_CC1 #5<br>TIM0_CC2 #4<br>TIM0_CDTI0 #3<br>TIM0_CDTI1 #2<br>TIM0_CDTI2 #1<br>TIM1_CC0 #6<br>TIM1_CC1 #5<br>TIM1_CC2 #4<br>TIM1_CC3 #3 LE-<br>TIM0_OUT0 #6 LE-<br>TIM0_OUT1 #5<br>PCNT0_S0IN #6<br>PCNT0_S1IN #5       | US0_TX #6<br>US0_RX #5<br>US0_CLK #4<br>US0_CS #3<br>US0_CTS #2<br>US0_RTS #1<br>US1_TX #6<br>US1_RX #5<br>US1_CLK #4<br>US1_CS #3<br>US1_CTS #2<br>US1_RTS #1<br>LEU0_TX #6<br>LEU0_RX #5<br>I2C0_SDA #6<br>I2C0_SCL #5         | FRC_DCLK #6<br>FRC_DOUT #5<br>FRC_DFRAME #4<br>MODEM_DCLK #6<br>MODEM_DIN #5<br>MODEM_DOUT #4<br>MODEM_ANT0 #3<br>MODEM_ANT1 #2     | PRS_CH6 #6<br>PRS_CH7 #5<br>PRS_CH8 #4<br>PRS_CH9 #3<br>ACMP0_O #6<br>ACMP1_O #6                 |
| 20                  | PB12     | BUSCX [ADC0:<br>APORT3XCH28<br>ACMP0:<br>APORT3XCH28<br>ACMP1:<br>APORT3XCH28<br>IDAC0:<br>APORT1XCH28]<br>BUSDY [ADC0:<br>APORT4YCH28<br>ACMP0:<br>APORT4YCH28<br>ACMP1:<br>APORT4YCH28]       | TIM0_CC0 #7<br>TIM0_CC1 #6<br>TIM0_CC2 #5<br>TIM0_CDTI0 #4<br>TIM0_CDTI1 #3<br>TIM0_CDTI2 #2<br>TIM1_CC0 #7<br>TIM1_CC1 #6<br>TIM1_CC2 #5<br>TIM1_CC3 #4 LE-<br>TIM0_OUT0 #7 LE-<br>TIM0_OUT1 #6<br>PCNT0_S0IN #7<br>PCNT0_S1IN #6       | US0_TX #7<br>US0_RX #6<br>US0_CLK #5<br>US0_CS #4<br>US0_CTS #3<br>US0_RTS #2<br>US1_TX #7<br>US1_RX #6<br>US1_CLK #5<br>US1_CS #4<br>US1_CTS #3<br>US1_RTS #2<br>LEU0_TX #7<br>LEU0_RX #6<br>I2C0_SDA #7<br>I2C0_SCL #6         | FRC_DCLK #7<br>FRC_DOUT #6<br>FRC_DFRAME #5<br>MODEM_DCLK #7<br>MODEM_DIN #6<br>MODEM_DOUT #5<br>MODEM_ANT0 #4<br>MODEM_ANT1 #3     | PRS_CH6 #7<br>PRS_CH7 #6<br>PRS_CH8 #5<br>PRS_CH9 #4<br>ACMP0_O #7<br>ACMP1_O #7                 |

| QFN32 Pin# and Name |          | Pin Alternate Functionality / Description   |  |  |   |   |
|---------------------|----------|---|--|--|---|---|
| Pin #               | Pin Name | Analog  | Timers   | Communication  | Radio   | Other   |
| 21                  | PB13     | BUSCY [ADC0: APORT3YCH29 ACMP0: APORT3YCH29 ACMP1: APORT3YCH29 IDAC0: APORT1YCH29]<br><br>BUSDX [ADC0: APORT4XCH29 ACMP0: APORT4XCH29 ACMP1: APORT4XCH29]                 | TIM0_CC0 #8<br>TIM0_CC1 #7<br>TIM0_CC2 #6<br>TIM0_CDT10 #5<br>TIM0_CDT11 #4<br>TIM0_CDT12 #3<br>TIM1_CC0 #8<br>TIM1_CC1 #7<br>TIM1_CC2 #6<br>TIM1_CC3 #5 LE-<br>TIM0_OUT0 #8 LE-<br>TIM0_OUT1 #7<br>PCNT0_S0IN #8<br>PCNT0_S1IN #7   | US0_TX #8<br>US0_RX #7<br>US0_CLK #6<br>US0_CS #5<br>US0_CTS #4<br>US0_RTS #3<br>US1_TX #8<br>US1_RX #7<br>US1_CLK #6<br>US1_CS #5<br>US1_CTS #4<br>US1_RTS #3<br>LEU0_TX #8<br>LEU0_RX #7<br>I2C0_SDA #8<br>I2C0_SCL #7     | FRC_DCLK #8<br>FRC_DOUT #7<br>FRC_DFRAME #6<br>MODEM_DCLK #8<br>MODEM_DIN #7<br>MODEM_DOUT #6<br>MODEM_ANT0 #5<br>MODEM_ANT1 #4   | PRS_CH6 #8<br>PRS_CH7 #7<br>PRS_CH8 #6<br>PRS_CH9 #5<br>ACMP0_O #8<br>ACMP1_O #8<br>DBG_SWO #1<br>GPIO_EM4WU9 |
| 22                  | AVDD     | Analog power supply.  |  |  |   |   |
| 23                  | PB14     | LFXTAL_N<br><br>BUSCX [ADC0: APORT3XCH30 ACMP0: APORT3XCH30 ACMP1: APORT3XCH30 IDAC0: APORT1XCH30]<br><br>BUSDY [ADC0: APORT4YCH30 ACMP0: APORT4YCH30 ACMP1: APORT4YCH30] | TIM0_CC0 #9<br>TIM0_CC1 #8<br>TIM0_CC2 #7<br>TIM0_CDT10 #6<br>TIM0_CDT11 #5<br>TIM0_CDT12 #4<br>TIM1_CC0 #9<br>TIM1_CC1 #8<br>TIM1_CC2 #7<br>TIM1_CC3 #6 LE-<br>TIM0_OUT0 #9 LE-<br>TIM0_OUT1 #8<br>PCNT0_S0IN #9<br>PCNT0_S1IN #8   | US0_TX #9<br>US0_RX #8<br>US0_CLK #7<br>US0_CS #6<br>US0_CTS #5<br>US0_RTS #4<br>US1_TX #9<br>US1_RX #8<br>US1_CLK #7<br>US1_CS #6<br>US1_CTS #5<br>US1_RTS #4<br>LEU0_TX #9<br>LEU0_RX #8<br>I2C0_SDA #9<br>I2C0_SCL #8     | FRC_DCLK #9<br>FRC_DOUT #8<br>FRC_DFRAME #7<br>MODEM_DCLK #9<br>MODEM_DIN #8<br>MODEM_DOUT #7<br>MODEM_ANT0 #6<br>MODEM_ANT1 #5   | CMU_CLK1 #1<br>PRS_CH6 #9<br>PRS_CH7 #8<br>PRS_CH8 #7<br>PRS_CH9 #6<br>ACMP0_O #9<br>ACMP1_O #9               |
| 24                  | PB15     | LFXTAL_P<br><br>BUSCY [ADC0: APORT3YCH31 ACMP0: APORT3YCH31 ACMP1: APORT3YCH31 IDAC0: APORT1YCH31]<br><br>BUSDX [ADC0: APORT4XCH31 ACMP0: APORT4XCH31 ACMP1: APORT4XCH31] | TIM0_CC0 #10<br>TIM0_CC1 #9<br>TIM0_CC2 #8<br>TIM0_CDT10 #7<br>TIM0_CDT11 #6<br>TIM0_CDT12 #5<br>TIM1_CC0 #10<br>TIM1_CC1 #9<br>TIM1_CC2 #8<br>TIM1_CC3 #7 LE-<br>TIM0_OUT0 #10<br>LETIM0_OUT1 #9<br>PCNT0_S0IN #10<br>PCNT0_S1IN #9 | US0_TX #10<br>US0_RX #9<br>US0_CLK #8<br>US0_CS #7<br>US0_CTS #6<br>US0_RTS #5<br>US1_TX #10<br>US1_RX #9<br>US1_CLK #8<br>US1_CS #7<br>US1_CTS #6<br>US1_RTS #5<br>LEU0_TX #10<br>LEU0_RX #9<br>I2C0_SDA #10<br>I2C0_SCL #9 | FRC_DCLK #10<br>FRC_DOUT #9<br>FRC_DFRAME #8<br>MODEM_DCLK #10<br>MODEM_DIN #9<br>MODEM_DOUT #8<br>MODEM_ANT0 #7<br>MODEM_ANT1 #6 | CMU_CLK0 #1<br>PRS_CH6 #10<br>PRS_CH7 #9<br>PRS_CH8 #8<br>PRS_CH9 #7<br>ACMP0_O #10<br>ACMP1_O #10            |
| 25                  | VREGVSS  | Voltage regulator VSS   |  |  |   |   |
| 26                  | VREGSW   | DCDC regulator switching node   |  |  |   |   |
| 27                  | VREGVDD  | Voltage regulator VDD input   |  |  |   |   |
| 28                  | DVDD     | Digital power supply.   |  |  |   |   |

| QFN32 Pin# and Name |          | Pin Alternate Functionality / Description  |  |  |   |   |
|---------------------|----------|--|--|--|---|---|
| Pin #               | Pin Name | Analog   | Timers   | Communication  | Radio   | Other   |
| 29                  | DECOUPLE | Decouple output for on-chip voltage regulator. An external decoupling capacitor is required at this pin.                               |  |  |   |   |
| 30                  | IOVDD    | Digital IO power supply.   |  |  |   |   |
| 31                  | PC10     | BUSAX [ADC0: APORT1XCH10 ACMP0: APORT1XCH10 ACMP1: APORT1XCH10]<br><br>BUSBY [ADC0: APORT2YCH10 ACMP0: APORT2YCH10 ACMP1: APORT2YCH10] | TIM0_CC0 #15<br>TIM0_CC1 #14<br>TIM0_CC2 #13<br>TIM0_CDTI0 #12<br>TIM0_CDTI1 #11<br>TIM0_CDTI2 #10<br>TIM1_CC0 #15<br>TIM1_CC1 #14<br>TIM1_CC2 #13<br>TIM1_CC3 #12 LE-<br>TIM0_OUT0 #15<br>LETIM0_OUT1 #14<br>PCNT0_S0IN #15<br>PCNT0_S1IN #14 | US0_TX #15<br>US0_RX #14<br>US0_CLK #13<br>US0_CS #12<br>US0_CTS #11<br>US0_RTS #10<br>US1_TX #15<br>US1_RX #14<br>US1_CLK #13<br>US1_CS #12<br>US1_CTS #11<br>US1_RTS #10<br>LEU0_TX #15<br>LEU0_RX #14<br>I2C0_SDA #15<br>I2C0_SCL #14 | FRC_DCLK #15<br>FRC_DOUT #14<br>FRC_DFRAME #13<br>MODEM_DCLK #15<br>MODEM_DIN #14<br>MODEM_DOUT #13<br>MODEM_ANT0 #12<br>MODEM_ANT1 #11 | CMU_CLK1 #3<br>PRS_CH0 #12<br>PRS_CH9 #15<br>PRS_CH10 #4<br>PRS_CH11 #3<br>ACMP0_O #15<br>ACMP1_O #15<br>GPIO_EM4WU12 |
| 32                  | PC11     | BUSAY [ADC0: APORT1YCH11 ACMP0: APORT1YCH11 ACMP1: APORT1YCH11]<br><br>BUSBX [ADC0: APORT2XCH11 ACMP0: APORT2XCH11 ACMP1: APORT2XCH11] | TIM0_CC0 #16<br>TIM0_CC1 #15<br>TIM0_CC2 #14<br>TIM0_CDTI0 #13<br>TIM0_CDTI1 #12<br>TIM0_CDTI2 #11<br>TIM1_CC0 #16<br>TIM1_CC1 #15<br>TIM1_CC2 #14<br>TIM1_CC3 #13 LE-<br>TIM0_OUT0 #16<br>LETIM0_OUT1 #15<br>PCNT0_S0IN #16<br>PCNT0_S1IN #15 | US0_TX #16<br>US0_RX #15<br>US0_CLK #14<br>US0_CS #13<br>US0_CTS #12<br>US0_RTS #11<br>US1_TX #16<br>US1_RX #15<br>US1_CLK #14<br>US1_CS #13<br>US1_CTS #12<br>US1_RTS #11<br>LEU0_TX #16<br>LEU0_RX #15<br>I2C0_SDA #16<br>I2C0_SCL #15 | FRC_DCLK #16<br>FRC_DOUT #15<br>FRC_DFRAME #14<br>MODEM_DCLK #16<br>MODEM_DIN #15<br>MODEM_DOUT #14<br>MODEM_ANT0 #13<br>MODEM_ANT1 #12 | CMU_CLK0 #3<br>PRS_CH0 #13<br>PRS_CH9 #16<br>PRS_CH10 #5<br>PRS_CH11 #4<br>ACMP0_O #16<br>ACMP1_O #16<br>DBG_SWO #3   |

### 6.4.1 EFR32FG1 QFN32 Sub-GHz GPIO Overview

The GPIO pins are organized as 16-bit ports indicated by letters A through F, and the individual pins on each port are indicated by a number from 15 down to 0.

Table 6.8. QFN32 Sub-GHz GPIO Pinout

| Port   | Pin 15    | Pin 14    | Pin 13    | Pin 12    | Pin 11    | Pin 10    | Pin 9 | Pin 8 | Pin 7 | Pin 6 | Pin 5 | Pin 4 | Pin 3    | Pin 2    | Pin 1    | Pin 0    |
|--------|-----------|-----------|-----------|-----------|-----------|-----------|-------|-------|-------|-------|-------|-------|----------|----------|----------|----------|
| Port A | -         | -         | -         | -         | -         | -         | -     | -     | -     | -     | -     | -     | -        | -        | PA1      | PA0      |
| Port B | PB15      | PB14      | PB13 (5V) | PB12 (5V) | PB11 (5V) | -         | -     | -     | -     | -     | -     | -     | -        | -        | -        | -        |
| Port C | -         | -         | -         | -         | PC11 (5V) | PC10 (5V) | -     | -     | -     | -     | -     | -     | -        | -        | -        | -        |
| Port D | PD15 (5V) | PD14 (5V) | PD13 (5V) | -         | -         | -         | -     | -     | -     | -     | -     | -     | -        | -        | -        | -        |
| Port F | -         | -         | -         | -         | -         | -         | -     | -     | -     | -     | -     | -     | PF3 (5V) | PF2 (5V) | PF1 (5V) | PF0 (5V) |

### 6.5 EFR32FG1 QFN32 2.4 GHz Definition

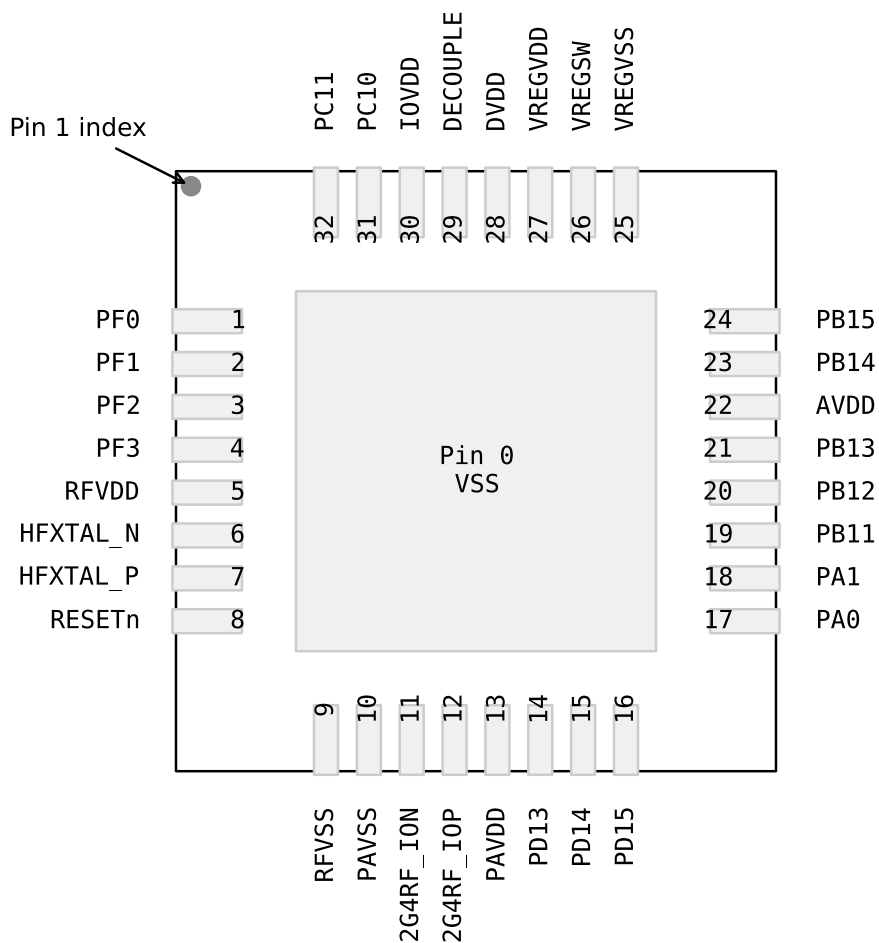


Figure 6.5. EFR32FG1 QFN32 2.4 GHz Pinout

Table 6.9. QFN32 2.4 GHz Device Pinout

| QFN32 Pin# and Name |          | Pin Alternate Functionality / Description  |  |  |   |  |
|---------------------|----------|--|--|--|---|--|
| Pin #               | Pin Name | Analog   | Timers   | Communication  | Radio   | Other  |
| 0                   | VSS      | Ground   |  |  |   |  |
| 1                   | PF0      | BUSAX [ADC0:<br>APORT1XCH16<br>ACMP0:<br>APORT1XCH16<br>ACMP1:<br>APORT1XCH16]<br><br>BUSBY [ADC0:<br>APORT2YCH16<br>ACMP0:<br>APORT2YCH16<br>ACMP1:<br>APORT2YCH16] | TIM0_CC0 #24<br>TIM0_CC1 #23<br>TIM0_CC2 #22<br>TIM0_CDTI0 #21<br>TIM0_CDTI1 #20<br>TIM0_CDTI2 #19<br>TIM1_CC0 #24<br>TIM1_CC1 #23<br>TIM1_CC2 #22<br>TIM1_CC3 #21 LE-<br>TIM0_OUT0 #24<br>LETIM0_OUT1 #23<br>PCNT0_S0IN #24<br>PCNT0_S1IN #23 | US0_TX #24<br>US0_RX #23<br>US0_CLK #22<br>US0_CS #21<br>US0_CTS #20<br>US0_RTS #19<br>US1_TX #24<br>US1_RX #23<br>US1_CLK #22<br>US1_CS #21<br>US1_CTS #20<br>US1_RTS #19<br>LEU0_TX #24<br>LEU0_RX #23<br>I2C0_SDA #24<br>I2C0_SCL #23 | FRC_DCLK #24<br>FRC_DOUT #23<br>FRC_DFRAME #22<br>MODEM_DCLK #24<br>MODEM_DIN #23<br>MODEM_DOUT #22<br>MODEM_ANT0 #21<br>MODEM_ANT1 #20 | PRS_CH0 #0<br>PRS_CH1 #7<br>PRS_CH2 #6<br>PRS_CH3 #5<br>ACMP0_O #24<br>ACMP1_O #24<br>DBG_SWCLKTCK #0  |
| 2                   | PF1      | BUSAY [ADC0:<br>APORT1YCH17<br>ACMP0:<br>APORT1YCH17<br>ACMP1:<br>APORT1YCH17]<br><br>BUSBX [ADC0:<br>APORT2XCH17<br>ACMP0:<br>APORT2XCH17<br>ACMP1:<br>APORT2XCH17] | TIM0_CC0 #25<br>TIM0_CC1 #24<br>TIM0_CC2 #23<br>TIM0_CDTI0 #22<br>TIM0_CDTI1 #21<br>TIM0_CDTI2 #20<br>TIM1_CC0 #25<br>TIM1_CC1 #24<br>TIM1_CC2 #23<br>TIM1_CC3 #22 LE-<br>TIM0_OUT0 #25<br>LETIM0_OUT1 #24<br>PCNT0_S0IN #25<br>PCNT0_S1IN #24 | US0_TX #25<br>US0_RX #24<br>US0_CLK #23<br>US0_CS #22<br>US0_CTS #21<br>US0_RTS #20<br>US1_TX #25<br>US1_RX #24<br>US1_CLK #23<br>US1_CS #22<br>US1_CTS #21<br>US1_RTS #20<br>LEU0_TX #25<br>LEU0_RX #24<br>I2C0_SDA #25<br>I2C0_SCL #24 | FRC_DCLK #25<br>FRC_DOUT #24<br>FRC_DFRAME #23<br>MODEM_DCLK #25<br>MODEM_DIN #24<br>MODEM_DOUT #23<br>MODEM_ANT0 #22<br>MODEM_ANT1 #21 | PRS_CH0 #1<br>PRS_CH1 #0<br>PRS_CH2 #7<br>PRS_CH3 #6<br>ACMP0_O #25<br>ACMP1_O #25<br>DBG_SWDIOTMS #0  |
| 3                   | PF2      | BUSAX [ADC0:<br>APORT1XCH18<br>ACMP0:<br>APORT1XCH18<br>ACMP1:<br>APORT1XCH18]<br><br>BUSBY [ADC0:<br>APORT2YCH18<br>ACMP0:<br>APORT2YCH18<br>ACMP1:<br>APORT2YCH18] | TIM0_CC0 #26<br>TIM0_CC1 #25<br>TIM0_CC2 #24<br>TIM0_CDTI0 #23<br>TIM0_CDTI1 #22<br>TIM0_CDTI2 #21<br>TIM1_CC0 #26<br>TIM1_CC1 #25<br>TIM1_CC2 #24<br>TIM1_CC3 #23 LE-<br>TIM0_OUT0 #26<br>LETIM0_OUT1 #25<br>PCNT0_S0IN #26<br>PCNT0_S1IN #25 | US0_TX #26<br>US0_RX #25<br>US0_CLK #24<br>US0_CS #23<br>US0_CTS #22<br>US0_RTS #21<br>US1_TX #26<br>US1_RX #25<br>US1_CLK #24<br>US1_CS #23<br>US1_CTS #22<br>US1_RTS #21<br>LEU0_TX #26<br>LEU0_RX #25<br>I2C0_SDA #26<br>I2C0_SCL #25 | FRC_DCLK #26<br>FRC_DOUT #25<br>FRC_DFRAME #24<br>MODEM_DCLK #26<br>MODEM_DIN #25<br>MODEM_DOUT #24<br>MODEM_ANT0 #23<br>MODEM_ANT1 #22 | CMU_CLK0 #6<br>PRS_CH0 #2<br>PRS_CH1 #1<br>PRS_CH2 #0<br>PRS_CH3 #7<br>ACMP0_O #26<br>ACMP1_O #26<br>DBG_TDO #0<br>DBG_SWO #0<br>GPIO_EM4WU0 |

| QFN32 Pin# and Name |           | Pin Alternate Functionality / Description   |  |  |   |   |
|---------------------|-----------|---|--|--|---|---|
| Pin #               | Pin Name  | Analog  | Timers   | Communication  | Radio   | Other   |
| 4                   | PF3       | BUSAY [ADC0: APORT1YCH19 ACMP0: APORT1YCH19 ACMP1: APORT1YCH19]<br><br>BUSBX [ADC0: APORT2XCH19 ACMP0: APORT2XCH19 ACMP1: APORT2XCH19]  | TIM0_CC0 #27<br>TIM0_CC1 #26<br>TIM0_CC2 #25<br>TIM0_CDTI0 #24<br>TIM0_CDTI1 #23<br>TIM0_CDTI2 #22<br>TIM1_CC0 #27<br>TIM1_CC1 #26<br>TIM1_CC2 #25<br>TIM1_CC3 #24 LE-<br>TIM0_OUT0 #27<br>LETIM0_OUT1 #26<br>PCNT0_S0IN #27<br>PCNT0_S1IN #26 | US0_TX #27<br>US0_RX #26<br>US0_CLK #25<br>US0_CS #24<br>US0_CTS #23<br>US0_RTS #22<br>US1_TX #27<br>US1_RX #26<br>US1_CLK #25<br>US1_CS #24<br>US1_CTS #23<br>US1_RTS #22<br>LEU0_TX #27<br>LEU0_RX #26<br>I2C0_SDA #27<br>I2C0_SCL #26 | FRC_DCLK #27<br>FRC_DOUT #26<br>FRC_DFRAME #25<br>MODEM_DCLK #27<br>MODEM_DIN #26<br>MODEM_DOUT #25<br>MODEM_ANT0 #24<br>MODEM_ANT1 #23 | CMU_CLK1 #6<br>PRS_CH0 #3<br>PRS_CH1 #2<br>PRS_CH2 #1<br>PRS_CH3 #0<br>ACMP0_O #27<br>ACMP1_O #27<br>DBG_TDI #0 |
| 5                   | RFVDD     | Radio power supply  |  |  |   |   |
| 6                   | HFXTAL_N  | High Frequency Crystal input pin.   |  |  |   |   |
| 7                   | HFXTAL_P  | High Frequency Crystal output pin.  |  |  |   |   |
| 8                   | RESETn    | Reset input, active low. To apply an external reset source to this pin, it is required to only drive this pin low during reset, and let the internal pull-up ensure that reset is released. |  |  |   |   |
| 9                   | RFVSS     | Radio Ground  |  |  |   |   |
| 10                  | PAVSS     | Power Amplifier (PA) voltage regulator VSS  |  |  |   |   |
| 11                  | 2G4RF_ION | 2.4 GHz Differential RF input/output, negative path.  |  |  |   |   |
| 12                  | 2G4RF_IOP | 2.4 GHz Differential RF input/output, positive path.  |  |  |   |   |
| 13                  | PAVDD     | Power Amplifier (PA) voltage regulator VDD input  |  |  |   |   |
| 14                  | PD13      | BUSCY [ADC0: APORT3YCH5 ACMP0: APORT3YCH5 ACMP1: APORT3YCH5 IDAC0: APORT1YCH5]<br><br>BUSDX [ADC0: APORT4XCH5 ACMP0: APORT4XCH5 ACMP1: APORT4XCH5]  | TIM0_CC0 #21<br>TIM0_CC1 #20<br>TIM0_CC2 #19<br>TIM0_CDTI0 #18<br>TIM0_CDTI1 #17<br>TIM0_CDTI2 #16<br>TIM1_CC0 #21<br>TIM1_CC1 #20<br>TIM1_CC2 #19<br>TIM1_CC3 #18 LE-<br>TIM0_OUT0 #21<br>LETIM0_OUT1 #20<br>PCNT0_S0IN #21<br>PCNT0_S1IN #20 | US0_TX #21<br>US0_RX #20<br>US0_CLK #19<br>US0_CS #18<br>US0_CTS #17<br>US0_RTS #16<br>US1_TX #21<br>US1_RX #20<br>US1_CLK #19<br>US1_CS #18<br>US1_CTS #17<br>US1_RTS #16<br>LEU0_TX #21<br>LEU0_RX #20<br>I2C0_SDA #21<br>I2C0_SCL #20 | FRC_DCLK #21<br>FRC_DOUT #20<br>FRC_DFRAME #19<br>MODEM_DCLK #21<br>MODEM_DIN #20<br>MODEM_DOUT #19<br>MODEM_ANT0 #18<br>MODEM_ANT1 #17 | PRS_CH3 #12<br>PRS_CH4 #4<br>PRS_CH5 #3<br>PRS_CH6 #15<br>ACMP0_O #21<br>ACMP1_O #21                            |



| QFN32 Pin# and Name |          | Pin Alternate Functionality / Description   |  |  |   |  |
|---------------------|----------|---|--|--|---|--|
| Pin #               | Pin Name | Analog  | Timers   | Communication  | Radio   | Other  |
| 15                  | PD14     | BUSCX [ADC0:<br>APORT3XCH6<br>ACMP0:<br>APORT3XCH6<br>ACMP1:<br>APORT3XCH6<br>IDAC0:<br>APORT1XCH6]<br><br>BUSDY [ADC0:<br>APORT4YCH6<br>ACMP0:<br>APORT4YCH6<br>ACMP1:<br>APORT4YCH6]                  | TIM0_CC0 #22<br>TIM0_CC1 #21<br>TIM0_CC2 #20<br>TIM0_CDTI0 #19<br>TIM0_CDTI1 #18<br>TIM0_CDTI2 #17<br>TIM1_CC0 #22<br>TIM1_CC1 #21<br>TIM1_CC2 #20<br>TIM1_CC3 #19 LE-<br>TIM0_OUT0 #22<br>LETIM0_OUT1 #21<br>PCNT0_S0IN #22<br>PCNT0_S1IN #21 | US0_TX #22<br>US0_RX #21<br>US0_CLK #20<br>US0_CS #19<br>US0_CTS #18<br>US0_RTS #17<br>US1_TX #22<br>US1_RX #21<br>US1_CLK #20<br>US1_CS #19<br>US1_CTS #18<br>US1_RTS #17<br>LEU0_TX #22<br>LEU0_RX #21<br>I2C0_SDA #22<br>I2C0_SCL #21 | FRC_DCLK #22<br>FRC_DOUT #21<br>FRC_DFRAME #20<br>MODEM_DCLK #22<br>MODEM_DIN #21<br>MODEM_DOUT #20<br>MODEM_ANT0 #19<br>MODEM_ANT1 #18 | CMU_CLK0 #5<br>PRS_CH3 #13<br>PRS_CH4 #5<br>PRS_CH5 #4<br>PRS_CH6 #16<br>ACMP0_O #22<br>ACMP1_O #22<br>GPIO_EM4WU4 |
| 16                  | PD15     | BUSCY [ADC0:<br>APORT3YCH7<br>ACMP0:<br>APORT3YCH7<br>ACMP1:<br>APORT3YCH7<br>IDAC0:<br>APORT1YCH7]<br><br>BUSDX [ADC0:<br>APORT4XCH7<br>ACMP0:<br>APORT4XCH7<br>ACMP1:<br>APORT4XCH7]                  | TIM0_CC0 #23<br>TIM0_CC1 #22<br>TIM0_CC2 #21<br>TIM0_CDTI0 #20<br>TIM0_CDTI1 #19<br>TIM0_CDTI2 #18<br>TIM1_CC0 #23<br>TIM1_CC1 #22<br>TIM1_CC2 #21<br>TIM1_CC3 #20 LE-<br>TIM0_OUT0 #23<br>LETIM0_OUT1 #22<br>PCNT0_S0IN #23<br>PCNT0_S1IN #22 | US0_TX #23<br>US0_RX #22<br>US0_CLK #21<br>US0_CS #20<br>US0_CTS #19<br>US0_RTS #18<br>US1_TX #23<br>US1_RX #22<br>US1_CLK #21<br>US1_CS #20<br>US1_CTS #19<br>US1_RTS #18<br>LEU0_TX #23<br>LEU0_RX #22<br>I2C0_SDA #23<br>I2C0_SCL #22 | FRC_DCLK #23<br>FRC_DOUT #22<br>FRC_DFRAME #21<br>MODEM_DCLK #23<br>MODEM_DIN #22<br>MODEM_DOUT #21<br>MODEM_ANT0 #20<br>MODEM_ANT1 #19 | CMU_CLK1 #5<br>PRS_CH3 #14<br>PRS_CH4 #6<br>PRS_CH5 #5<br>PRS_CH6 #17<br>ACMP0_O #23<br>ACMP1_O #23<br>DBG_SWO #2  |
| 17                  | PA0      | ADC0_EXTN<br><br>BUSCX [ADC0:<br>APORT3XCH8<br>ACMP0:<br>APORT3XCH8<br>ACMP1:<br>APORT3XCH8<br>IDAC0:<br>APORT1XCH8]<br><br>BUSDY [ADC0:<br>APORT4YCH8<br>ACMP0:<br>APORT4YCH8<br>ACMP1:<br>APORT4YCH8] | TIM0_CC0 #0<br>TIM0_CC1 #31<br>TIM0_CC2 #30<br>TIM0_CDTI0 #29<br>TIM0_CDTI1 #28<br>TIM0_CDTI2 #27<br>TIM1_CC0 #0<br>TIM1_CC1 #31<br>TIM1_CC2 #30<br>TIM1_CC3 #29 LE-<br>TIM0_OUT0 #0 LE-<br>TIM0_OUT1 #31<br>PCNT0_S0IN #0<br>PCNT0_S1IN #31   | US0_TX #0<br>US0_RX #31<br>US0_CLK #30<br>US0_CS #29<br>US0_CTS #28<br>US0_RTS #27<br>US1_TX #0<br>US1_RX #31<br>US1_CLK #30<br>US1_CS #29<br>US1_CTS #28<br>US1_RTS #27<br>LEU0_TX #0<br>LEU0_RX #31<br>I2C0_SDA #0<br>I2C0_SCL #31     | FRC_DCLK #0<br>FRC_DOUT #31<br>FRC_DFRAME #30<br>MODEM_DCLK #0<br>MODEM_DIN #31<br>MODEM_DOUT #30<br>MODEM_ANT0 #29<br>MODEM_ANT1 #28   | CMU_CLK1 #0<br>PRS_CH6 #0<br>PRS_CH7 #10<br>PRS_CH8 #9<br>PRS_CH9 #8<br>ACMP0_O #0<br>ACMP1_O #0                   |

| QFN32 Pin# and Name |          | Pin Alternate Functionality / Description   |  |  |   |  |
|---------------------|----------|---|--|--|---|--|
| Pin #               | Pin Name | Analog  | Timers   | Communication  | Radio   | Other  |
| 18                  | PA1      | ADC0_EXTP<br>BUSCY [ADC0:<br>APORT3YCH9<br>ACMP0:<br>APORT3YCH9<br>ACMP1:<br>APORT3YCH9<br>IDAC0:<br>APORT1YCH9]<br>BUSDX [ADC0:<br>APORT4XCH9<br>ACMP0:<br>APORT4XCH9<br>ACMP1:<br>APORT4XCH9] | TIM0_CC0 #1<br>TIM0_CC1 #0<br>TIM0_CC2 #31<br>TIM0_CDTI0 #30<br>TIM0_CDTI1 #29<br>TIM0_CDTI2 #28<br>TIM1_CC0 #1<br>TIM1_CC1 #0<br>TIM1_CC2 #31<br>TIM1_CC3 #30 LE-<br>TIM0_OUT0 #1 LE-<br>TIM0_OUT1 #0<br>PCNT0_S0IN #1<br>PCNT0_S1IN #0 | US0_TX #1<br>US0_RX #0<br>US0_CLK #31<br>US0_CS #30<br>US0_CTS #29<br>US0_RTS #28<br>US1_TX #1<br>US1_RX #0<br>US1_CLK #31<br>US1_CS #30<br>US1_CTS #29<br>US1_RTS #28<br>LEU0_TX #1<br>LEU0_RX #0<br>I2C0_SDA #1<br>I2C0_SCL #0 | FRC_DCLK #1<br>FRC_DOUT #0<br>FRC_DFRAME #31<br>MODEM_DCLK #1<br>MODEM_DIN #0<br>MODEM_DOUT #31<br>MODEM_ANT0 #30<br>MODEM_ANT1 #29 | CMU_CLK0 #0<br>PRS_CH6 #1<br>PRS_CH7 #0<br>PRS_CH8 #10<br>PRS_CH9 #9<br>ACMP0_O #1<br>ACMP1_O #1 |
| 19                  | PB11     | BUSCY [ADC0:<br>APORT3YCH27<br>ACMP0:<br>APORT3YCH27<br>ACMP1:<br>APORT3YCH27<br>IDAC0:<br>APORT1YCH27]<br>BUSDX [ADC0:<br>APORT4XCH27<br>ACMP0:<br>APORT4XCH27<br>ACMP1:<br>APORT4XCH27]       | TIM0_CC0 #6<br>TIM0_CC1 #5<br>TIM0_CC2 #4<br>TIM0_CDTI0 #3<br>TIM0_CDTI1 #2<br>TIM0_CDTI2 #1<br>TIM1_CC0 #6<br>TIM1_CC1 #5<br>TIM1_CC2 #4<br>TIM1_CC3 #3 LE-<br>TIM0_OUT0 #6 LE-<br>TIM0_OUT1 #5<br>PCNT0_S0IN #6<br>PCNT0_S1IN #5       | US0_TX #6<br>US0_RX #5<br>US0_CLK #4<br>US0_CS #3<br>US0_CTS #2<br>US0_RTS #1<br>US1_TX #6<br>US1_RX #5<br>US1_CLK #4<br>US1_CS #3<br>US1_CTS #2<br>US1_RTS #1<br>LEU0_TX #6<br>LEU0_RX #5<br>I2C0_SDA #6<br>I2C0_SCL #5         | FRC_DCLK #6<br>FRC_DOUT #5<br>FRC_DFRAME #4<br>MODEM_DCLK #6<br>MODEM_DIN #5<br>MODEM_DOUT #4<br>MODEM_ANT0 #3<br>MODEM_ANT1 #2     | PRS_CH6 #6<br>PRS_CH7 #5<br>PRS_CH8 #4<br>PRS_CH9 #3<br>ACMP0_O #6<br>ACMP1_O #6                 |
| 20                  | PB12     | BUSCX [ADC0:<br>APORT3XCH28<br>ACMP0:<br>APORT3XCH28<br>ACMP1:<br>APORT3XCH28<br>IDAC0:<br>APORT1XCH28]<br>BUSDY [ADC0:<br>APORT4YCH28<br>ACMP0:<br>APORT4YCH28<br>ACMP1:<br>APORT4YCH28]       | TIM0_CC0 #7<br>TIM0_CC1 #6<br>TIM0_CC2 #5<br>TIM0_CDTI0 #4<br>TIM0_CDTI1 #3<br>TIM0_CDTI2 #2<br>TIM1_CC0 #7<br>TIM1_CC1 #6<br>TIM1_CC2 #5<br>TIM1_CC3 #4 LE-<br>TIM0_OUT0 #7 LE-<br>TIM0_OUT1 #6<br>PCNT0_S0IN #7<br>PCNT0_S1IN #6       | US0_TX #7<br>US0_RX #6<br>US0_CLK #5<br>US0_CS #4<br>US0_CTS #3<br>US0_RTS #2<br>US1_TX #7<br>US1_RX #6<br>US1_CLK #5<br>US1_CS #4<br>US1_CTS #3<br>US1_RTS #2<br>LEU0_TX #7<br>LEU0_RX #6<br>I2C0_SDA #7<br>I2C0_SCL #6         | FRC_DCLK #7<br>FRC_DOUT #6<br>FRC_DFRAME #5<br>MODEM_DCLK #7<br>MODEM_DIN #6<br>MODEM_DOUT #5<br>MODEM_ANT0 #4<br>MODEM_ANT1 #3     | PRS_CH6 #7<br>PRS_CH7 #6<br>PRS_CH8 #5<br>PRS_CH9 #4<br>ACMP0_O #7<br>ACMP1_O #7                 |

| QFN32 Pin# and Name |          | Pin Alternate Functionality / Description   |  |  |   |   |
|---------------------|----------|---|--|--|---|---|
| Pin #               | Pin Name | Analog  | Timers   | Communication  | Radio   | Other   |
| 21                  | PB13     | BUSCY [ADC0: APORT3YCH29 ACMP0: APORT3YCH29 ACMP1: APORT3YCH29 IDAC0: APORT1YCH29]<br><br>BUSDX [ADC0: APORT4XCH29 ACMP0: APORT4XCH29 ACMP1: APORT4XCH29]                 | TIM0_CC0 #8<br>TIM0_CC1 #7<br>TIM0_CC2 #6<br>TIM0_CDT10 #5<br>TIM0_CDT11 #4<br>TIM0_CDT12 #3<br>TIM1_CC0 #8<br>TIM1_CC1 #7<br>TIM1_CC2 #6<br>TIM1_CC3 #5 LE-<br>TIM0_OUT0 #8 LE-<br>TIM0_OUT1 #7<br>PCNT0_S0IN #8<br>PCNT0_S1IN #7   | US0_TX #8<br>US0_RX #7<br>US0_CLK #6<br>US0_CS #5<br>US0_CTS #4<br>US0_RTS #3<br>US1_TX #8<br>US1_RX #7<br>US1_CLK #6<br>US1_CS #5<br>US1_CTS #4<br>US1_RTS #3<br>LEU0_TX #8<br>LEU0_RX #7<br>I2C0_SDA #8<br>I2C0_SCL #7     | FRC_DCLK #8<br>FRC_DOUT #7<br>FRC_DFRAME #6<br>MODEM_DCLK #8<br>MODEM_DIN #7<br>MODEM_DOUT #6<br>MODEM_ANT0 #5<br>MODEM_ANT1 #4   | PRS_CH6 #8<br>PRS_CH7 #7<br>PRS_CH8 #6<br>PRS_CH9 #5<br>ACMP0_O #8<br>ACMP1_O #8<br>DBG_SWO #1<br>GPIO_EM4WU9 |
| 22                  | AVDD     | Analog power supply.  |  |  |   |   |
| 23                  | PB14     | LFXTAL_N<br><br>BUSCX [ADC0: APORT3XCH30 ACMP0: APORT3XCH30 ACMP1: APORT3XCH30 IDAC0: APORT1XCH30]<br><br>BUSDY [ADC0: APORT4YCH30 ACMP0: APORT4YCH30 ACMP1: APORT4YCH30] | TIM0_CC0 #9<br>TIM0_CC1 #8<br>TIM0_CC2 #7<br>TIM0_CDT10 #6<br>TIM0_CDT11 #5<br>TIM0_CDT12 #4<br>TIM1_CC0 #9<br>TIM1_CC1 #8<br>TIM1_CC2 #7<br>TIM1_CC3 #6 LE-<br>TIM0_OUT0 #9 LE-<br>TIM0_OUT1 #8<br>PCNT0_S0IN #9<br>PCNT0_S1IN #8   | US0_TX #9<br>US0_RX #8<br>US0_CLK #7<br>US0_CS #6<br>US0_CTS #5<br>US0_RTS #4<br>US1_TX #9<br>US1_RX #8<br>US1_CLK #7<br>US1_CS #6<br>US1_CTS #5<br>US1_RTS #4<br>LEU0_TX #9<br>LEU0_RX #8<br>I2C0_SDA #9<br>I2C0_SCL #8     | FRC_DCLK #9<br>FRC_DOUT #8<br>FRC_DFRAME #7<br>MODEM_DCLK #9<br>MODEM_DIN #8<br>MODEM_DOUT #7<br>MODEM_ANT0 #6<br>MODEM_ANT1 #5   | CMU_CLK1 #1<br>PRS_CH6 #9<br>PRS_CH7 #8<br>PRS_CH8 #7<br>PRS_CH9 #6<br>ACMP0_O #9<br>ACMP1_O #9               |
| 24                  | PB15     | LFXTAL_P<br><br>BUSCY [ADC0: APORT3YCH31 ACMP0: APORT3YCH31 ACMP1: APORT3YCH31 IDAC0: APORT1YCH31]<br><br>BUSDX [ADC0: APORT4XCH31 ACMP0: APORT4XCH31 ACMP1: APORT4XCH31] | TIM0_CC0 #10<br>TIM0_CC1 #9<br>TIM0_CC2 #8<br>TIM0_CDT10 #7<br>TIM0_CDT11 #6<br>TIM0_CDT12 #5<br>TIM1_CC0 #10<br>TIM1_CC1 #9<br>TIM1_CC2 #8<br>TIM1_CC3 #7 LE-<br>TIM0_OUT0 #10<br>LETIM0_OUT1 #9<br>PCNT0_S0IN #10<br>PCNT0_S1IN #9 | US0_TX #10<br>US0_RX #9<br>US0_CLK #8<br>US0_CS #7<br>US0_CTS #6<br>US0_RTS #5<br>US1_TX #10<br>US1_RX #9<br>US1_CLK #8<br>US1_CS #7<br>US1_CTS #6<br>US1_RTS #5<br>LEU0_TX #10<br>LEU0_RX #9<br>I2C0_SDA #10<br>I2C0_SCL #9 | FRC_DCLK #10<br>FRC_DOUT #9<br>FRC_DFRAME #8<br>MODEM_DCLK #10<br>MODEM_DIN #9<br>MODEM_DOUT #8<br>MODEM_ANT0 #7<br>MODEM_ANT1 #6 | CMU_CLK0 #1<br>PRS_CH6 #10<br>PRS_CH7 #9<br>PRS_CH8 #8<br>PRS_CH9 #7<br>ACMP0_O #10<br>ACMP1_O #10            |
| 25                  | VREGVSS  | Voltage regulator VSS   |  |  |   |   |
| 26                  | VREGSW   | DCDC regulator switching node   |  |  |   |   |
| 27                  | VREGVDD  | Voltage regulator VDD input   |  |  |   |   |
| 28                  | DVDD     | Digital power supply.   |  |  |   |   |

| QFN32 Pin# and Name |          | Pin Alternate Functionality / Description  |  |  |   |   |
|---------------------|----------|--|--|--|---|---|
| Pin #               | Pin Name | Analog   | Timers   | Communication  | Radio   | Other   |
| 29                  | DECOUPLE | Decouple output for on-chip voltage regulator. An external decoupling capacitor is required at this pin.   |  |  |   |   |
| 30                  | IOVDD    | Digital IO power supply.   |  |  |   |   |
| 31                  | PC10     | BUSAX [ADC0: APORT1XCH10<br>ACMP0: APORT1XCH10<br>ACMP1: APORT1XCH10]<br><br>BUSBY [ADC0: APORT2YCH10<br>ACMP0: APORT2YCH10<br>ACMP1: APORT2YCH10] | TIM0_CC0 #15<br>TIM0_CC1 #14<br>TIM0_CC2 #13<br>TIM0_CDTI0 #12<br>TIM0_CDTI1 #11<br>TIM0_CDTI2 #10<br>TIM1_CC0 #15<br>TIM1_CC1 #14<br>TIM1_CC2 #13<br>TIM1_CC3 #12 LE-<br>TIM0_OUT0 #15<br>LETIM0_OUT1 #14<br>PCNT0_S0IN #15<br>PCNT0_S1IN #14 | US0_TX #15<br>US0_RX #14<br>US0_CLK #13<br>US0_CS #12<br>US0_CTS #11<br>US0_RTS #10<br>US1_TX #15<br>US1_RX #14<br>US1_CLK #13<br>US1_CS #12<br>US1_CTS #11<br>US1_RTS #10<br>LEU0_TX #15<br>LEU0_RX #14<br>I2C0_SDA #15<br>I2C0_SCL #14 | FRC_DCLK #15<br>FRC_DOUT #14<br>FRC_DFRAME #13<br>MODEM_DCLK #15<br>MODEM_DIN #14<br>MODEM_DOUT #13<br>MODEM_ANT0 #12<br>MODEM_ANT1 #11 | CMU_CLK1 #3<br>PRS_CH0 #12<br>PRS_CH9 #15<br>PRS_CH10 #4<br>PRS_CH11 #3<br>ACMP0_O #15<br>ACMP1_O #15<br>GPIO_EM4WU12 |
| 32                  | PC11     | BUSAY [ADC0: APORT1YCH11<br>ACMP0: APORT1YCH11<br>ACMP1: APORT1YCH11]<br><br>BUSBX [ADC0: APORT2XCH11<br>ACMP0: APORT2XCH11<br>ACMP1: APORT2XCH11] | TIM0_CC0 #16<br>TIM0_CC1 #15<br>TIM0_CC2 #14<br>TIM0_CDTI0 #13<br>TIM0_CDTI1 #12<br>TIM0_CDTI2 #11<br>TIM1_CC0 #16<br>TIM1_CC1 #15<br>TIM1_CC2 #14<br>TIM1_CC3 #13 LE-<br>TIM0_OUT0 #16<br>LETIM0_OUT1 #15<br>PCNT0_S0IN #16<br>PCNT0_S1IN #15 | US0_TX #16<br>US0_RX #15<br>US0_CLK #14<br>US0_CS #13<br>US0_CTS #12<br>US0_RTS #11<br>US1_TX #16<br>US1_RX #15<br>US1_CLK #14<br>US1_CS #13<br>US1_CTS #12<br>US1_RTS #11<br>LEU0_TX #16<br>LEU0_RX #15<br>I2C0_SDA #16<br>I2C0_SCL #15 | FRC_DCLK #16<br>FRC_DOUT #15<br>FRC_DFRAME #14<br>MODEM_DCLK #16<br>MODEM_DIN #15<br>MODEM_DOUT #14<br>MODEM_ANT0 #13<br>MODEM_ANT1 #12 | CMU_CLK0 #3<br>PRS_CH0 #13<br>PRS_CH9 #16<br>PRS_CH10 #5<br>PRS_CH11 #4<br>ACMP0_O #16<br>ACMP1_O #16<br>DBG_SWO #3   |

### 6.5.1 EFR32FG1 QFN32 2.4 GHz GPIO Overview

The GPIO pins are organized as 16-bit ports indicated by letters A through F, and the individual pins on each port are indicated by a number from 15 down to 0.

Table 6.10. QFN32 2.4 GHz GPIO Pinout

| Port   | Pin 15    | Pin 14    | Pin 13    | Pin 12    | Pin 11    | Pin 10    | Pin 9 | Pin 8 | Pin 7 | Pin 6 | Pin 5 | Pin 4 | Pin 3    | Pin 2    | Pin 1    | Pin 0    |
|--------|-----------|-----------|-----------|-----------|-----------|-----------|-------|-------|-------|-------|-------|-------|----------|----------|----------|----------|
| Port A | -         | -         | -         | -         | -         | -         | -     | -     | -     | -     | -     | -     | -        | -        | PA1      | PA0      |
| Port B | PB15      | PB14      | PB13 (5V) | PB12 (5V) | PB11 (5V) | -         | -     | -     | -     | -     | -     | -     | -        | -        | -        | -        |
| Port C | -         | -         | -         | -         | PC11 (5V) | PC10 (5V) | -     | -     | -     | -     | -     | -     | -        | -        | -        | -        |
| Port D | PD15 (5V) | PD14 (5V) | PD13 (5V) | -         | -         | -         | -     | -     | -     | -     | -     | -     | -        | -        | -        | -        |
| Port F | -         | -         | -         | -         | -         | -         | -     | -     | -     | -     | -     | -     | PF3 (5V) | PF2 (5V) | PF1 (5V) | PF0 (5V) |

## 6.6 Alternate Functionality Pinout

A wide selection of alternate functionality is available for multiplexing to various pins. The following table shows the name of the alternate functionality in the first column, followed by columns showing the possible LOCATION bitfield settings.

**Note:** Some functionality, such as analog interfaces, do not have alternate settings or a LOCATION bitfield. In these cases, the pinout is shown in the column corresponding to LOCATION 0.

**Table 6.11. Alternate functionality overview**

| Alternate     | LOCATION                               |  |   |   |   |  |  |  |   |
|---------------|--|--|---|---|---|--|--|--|---|
| Functionality | 0 - 3                                  | 4 - 7                                  | 8 - 11                                    | 12 - 15                                   | 16 - 19                                     | 20 - 23                                      | 24 - 27                                  | 28 - 31                                  | Description   |
| ACMP0_O       | 0: PA0<br>1: PA1<br>2: PA2<br>3: PA3   | 4: PA4<br>5: PA5<br>6: PB11<br>7: PB12 | 8: PB13<br>9: PB14<br>10: PB15<br>11: PC6 | 12: PC7<br>13: PC8<br>14: PC9<br>15: PC10 | 16: PC11<br>17: PD9<br>18: PD10<br>19: PD11 | 20: PD12<br>21: PD13<br>22: PD14<br>23: PD15 | 24: PF0<br>25: PF1<br>26: PF2<br>27: PF3 | 28: PF4<br>29: PF5<br>30: PF6<br>31: PF7 | Analog comparator ACMP0, digital output.  |
| ACMP1_O       | 0: PA0<br>1: PA1<br>2: PA2<br>3: PA3   | 4: PA4<br>5: PA5<br>6: PB11<br>7: PB12 | 8: PB13<br>9: PB14<br>10: PB15<br>11: PC6 | 12: PC7<br>13: PC8<br>14: PC9<br>15: PC10 | 16: PC11<br>17: PD9<br>18: PD10<br>19: PD11 | 20: PD12<br>21: PD13<br>22: PD14<br>23: PD15 | 24: PF0<br>25: PF1<br>26: PF2<br>27: PF3 | 28: PF4<br>29: PF5<br>30: PF6<br>31: PF7 | Analog comparator ACMP1, digital output.  |
| ADC0_EXTN     | 0: PA0                                 |  |   |   |   |  |  |  | Analog to digital converter ADC0 external reference input negative pin  |
| ADC0_EXTP     | 0: PA1                                 |  |   |   |   |  |  |  | Analog to digital converter ADC0 external reference input positive pin  |
| CMU_CLK0      | 0: PA1<br>1: PB15<br>2: PC6<br>3: PC11 | 4: PD9<br>5: PD14<br>6: PF2<br>7: PF7  |   |   |   |  |  |  | Clock Management Unit, clock output number 0.   |
| CMU_CLK1      | 0: PA0<br>1: PB14<br>2: PC7<br>3: PC10 | 4: PD10<br>5: PD15<br>6: PF3<br>7: PF6 |   |   |   |  |  |  | Clock Management Unit, clock output number 1.   |
| DBG_SWCLKTCK  | 0: PF0                                 |  |   |   |   |  |  |  | Debug-interface Serial Wire clock input and JTAG Test Clock.<br><br>Note that this function is enabled to the pin out of reset, and has a built-in pull down.             |
| DBG_SWDIOTMS  | 0: PF1                                 |  |   |   |   |  |  |  | Debug-interface Serial Wire data input / output and JTAG Test Mode Select.<br><br>Note that this function is enabled to the pin out of reset, and has a built-in pull up. |

| Alternate     | LOCATION                                |  |   |  |  |  |  |  |   |
|---------------|---|--|---|--|--|--|--|--|---|
| Functionality | 0 - 3                                   | 4 - 7                                    | 8 - 11                                    | 12 - 15                                    | 16 - 19                                      | 20 - 23                                      | 24 - 27                                  | 28 - 31                                  | Description   |
| DBG_SWO       | 0: PF2<br>1: PB13<br>2: PD15<br>3: PC11 |  |   |  |  |  |  |  | Debug-interface Serial Wire viewer Output.<br><br>Note that this function is not enabled after reset, and must be enabled by software to be used. |
| DBG_TDI       | 0: PF3                                  |  |   |  |  |  |  |  | Debug-interface JTAG Test Data In.<br><br>Note that this function is enabled to pin out of reset, and has a built-in pull up.                     |
| DBG_TDO       | 0: PF2                                  |  |   |  |  |  |  |  | Debug-interface JTAG Test Data Out.<br><br>Note that this function is enabled to pin out of reset.  |
| FRC_DCLK      | 0: PA0<br>1: PA1<br>2: PA2<br>3: PA3    | 4: PA4<br>5: PA5<br>6: PB11<br>7: PB12   | 8: PB13<br>9: PB14<br>10: PB15<br>11: PC6 | 12: PC7<br>13: PC8<br>14: PC9<br>15: PC10  | 16: PC11<br>17: PD9<br>18: PD10<br>19: PD11  | 20: PD12<br>21: PD13<br>22: PD14<br>23: PD15 | 24: PF0<br>25: PF1<br>26: PF2<br>27: PF3 | 28: PF4<br>29: PF5<br>30: PF6<br>31: PF7 | Frame Controller, Data Sniffer Clock.   |
| FRC_DFRAME    | 0: PA2<br>1: PA3<br>2: PA4<br>3: PA5    | 4: PB11<br>5: PB12<br>6: PB13<br>7: PB14 | 8: PB15<br>9: PC6<br>10: PC7<br>11: PC8   | 12: PC9<br>13: PC10<br>14: PC11<br>15: PD9 | 16: PD10<br>17: PD11<br>18: PD12<br>19: PD13 | 20: PD14<br>21: PD15<br>22: PF0<br>23: PF1   | 24: PF2<br>25: PF3<br>26: PF4<br>27: PF5 | 28: PF6<br>29: PF7<br>30: PA0<br>31: PA1 | Frame Controller, Data Sniffer Frame active   |
| FRC_DOUT      | 0: PA1<br>1: PA2<br>2: PA3<br>3: PA4    | 4: PA5<br>5: PB11<br>6: PB12<br>7: PB13  | 8: PB14<br>9: PB15<br>10: PC6<br>11: PC7  | 12: PC8<br>13: PC9<br>14: PC10<br>15: PC11 | 16: PD9<br>17: PD10<br>18: PD11<br>19: PD12  | 20: PD13<br>21: PD14<br>22: PD15<br>23: PF0  | 24: PF1<br>25: PF2<br>26: PF3<br>27: PF4 | 28: PF5<br>29: PF6<br>30: PF7<br>31: PA0 | Frame Controller, Data Sniffer Output.  |
| GPIO_EM4WU0   | 0: PF2                                  |  |   |  |  |  |  |  | Pin can be used to wake the system up from EM4  |
| GPIO_EM4WU1   | 0: PF7                                  |  |   |  |  |  |  |  | Pin can be used to wake the system up from EM4  |
| GPIO_EM4WU4   | 0: PD14                                 |  |   |  |  |  |  |  | Pin can be used to wake the system up from EM4  |
| GPIO_EM4WU8   | 0: PA3                                  |  |   |  |  |  |  |  | Pin can be used to wake the system up from EM4  |

| Alternate    | LOCATION                               |  |   |   |  |  |  |  | Description   |
|--------------|--|--|---|---|--|--|--|--|---|
|              | 0 - 3                                  | 4 - 7                                    | 8 - 11                                    | 12 - 15                                     | 16 - 19                                      | 20 - 23                                      | 24 - 27                                  | 28 - 31                                  |   |
| GPIO_EM4WU9  | 0: PB13                                |  |   |   |  |  |  |  | Pin can be used to wake the system up from EM4  |
| GPIO_EM4WU12 | 0: PC10                                |  |   |   |  |  |  |  | Pin can be used to wake the system up from EM4  |
| I2C0_SCL     | 0: PA1<br>1: PA2<br>2: PA3<br>3: PA4   | 4: PA5<br>5: PB11<br>6: PB12<br>7: PB13  | 8: PB14<br>9: PB15<br>10: PC6<br>11: PC7  | 12: PC8<br>13: PC9<br>14: PC10<br>15: PC11  | 16: PD9<br>17: PD10<br>18: PD11<br>19: PD12  | 20: PD13<br>21: PD14<br>22: PD15<br>23: PF0  | 24: PF1<br>25: PF2<br>26: PF3<br>27: PF4 | 28: PF5<br>29: PF6<br>30: PF7<br>31: PA0 | I2C0 Serial Clock Line input / output.  |
| I2C0_SDA     | 0: PA0<br>1: PA1<br>2: PA2<br>3: PA3   | 4: PA4<br>5: PA5<br>6: PB11<br>7: PB12   | 8: PB13<br>9: PB14<br>10: PB15<br>11: PC6 | 12: PC7<br>13: PC8<br>14: PC9<br>15: PC10   | 16: PC11<br>17: PD9<br>18: PD10<br>19: PD11  | 20: PD12<br>21: PD13<br>22: PD14<br>23: PD15 | 24: PF0<br>25: PF1<br>26: PF2<br>27: PF3 | 28: PF4<br>29: PF5<br>30: PF6<br>31: PF7 | I2C0 Serial Data input / output.  |
| LETIM0_OUT0  | 0: PA0<br>1: PA1<br>2: PA2<br>3: PA3   | 4: PA4<br>5: PA5<br>6: PB11<br>7: PB12   | 8: PB13<br>9: PB14<br>10: PB15<br>11: PC6 | 12: PC7<br>13: PC8<br>14: PC9<br>15: PC10   | 16: PC11<br>17: PD9<br>18: PD10<br>19: PD11  | 20: PD12<br>21: PD13<br>22: PD14<br>23: PD15 | 24: PF0<br>25: PF1<br>26: PF2<br>27: PF3 | 28: PF4<br>29: PF5<br>30: PF6<br>31: PF7 | Low Energy Timer LETIM0, output channel 0.  |
| LETIM0_OUT1  | 0: PA1<br>1: PA2<br>2: PA3<br>3: PA4   | 4: PA5<br>5: PB11<br>6: PB12<br>7: PB13  | 8: PB14<br>9: PB15<br>10: PC6<br>11: PC7  | 12: PC8<br>13: PC9<br>14: PC10<br>15: PC11  | 16: PD9<br>17: PD10<br>18: PD11<br>19: PD12  | 20: PD13<br>21: PD14<br>22: PD15<br>23: PF0  | 24: PF1<br>25: PF2<br>26: PF3<br>27: PF4 | 28: PF5<br>29: PF6<br>30: PF7<br>31: PA0 | Low Energy Timer LETIM0, output channel 1.  |
| LEU0_RX      | 0: PA1<br>1: PA2<br>2: PA3<br>3: PA4   | 4: PA5<br>5: PB11<br>6: PB12<br>7: PB13  | 8: PB14<br>9: PB15<br>10: PC6<br>11: PC7  | 12: PC8<br>13: PC9<br>14: PC10<br>15: PC11  | 16: PD9<br>17: PD10<br>18: PD11<br>19: PD12  | 20: PD13<br>21: PD14<br>22: PD15<br>23: PF0  | 24: PF1<br>25: PF2<br>26: PF3<br>27: PF4 | 28: PF5<br>29: PF6<br>30: PF7<br>31: PA0 | LEUART0 Receive input.  |
| LEU0_TX      | 0: PA0<br>1: PA1<br>2: PA2<br>3: PA3   | 4: PA4<br>5: PA5<br>6: PB11<br>7: PB12   | 8: PB13<br>9: PB14<br>10: PB15<br>11: PC6 | 12: PC7<br>13: PC8<br>14: PC9<br>15: PC10   | 16: PC11<br>17: PD9<br>18: PD10<br>19: PD11  | 20: PD12<br>21: PD13<br>22: PD14<br>23: PD15 | 24: PF0<br>25: PF1<br>26: PF2<br>27: PF3 | 28: PF4<br>29: PF5<br>30: PF6<br>31: PF7 | LEUART0 Transmit output. Also used as receive input in half duplex communication.                             |
| LFXTAL_N     | 0: PB14                                |  |   |   |  |  |  |  | Low Frequency Crystal (typically 32.768 kHz) negative pin. Also used as an optional external clock input pin. |
| LFXTAL_P     | 0: PB15                                |  |   |   |  |  |  |  | Low Frequency Crystal (typically 32.768 kHz) positive pin.  |
| MODEM_ANT0   | 0: PA3<br>1: PA4<br>2: PA5<br>3: PB11  | 4: PB12<br>5: PB13<br>6: PB14<br>7: PB15 | 8: PC6<br>9: PC7<br>10: PC8<br>11: PC9    | 12: PC10<br>13: PC11<br>14: PD9<br>15: PD10 | 16: PD11<br>17: PD12<br>18: PD13<br>19: PD14 | 20: PD15<br>21: PF0<br>22: PF1<br>23: PF2    | 24: PF3<br>25: PF4<br>26: PF5<br>27: PF6 | 28: PF7<br>29: PA0<br>30: PA1<br>31: PA2 | MODEM antenna control output 0, used for antenna diversity.   |
| MODEM_ANT1   | 0: PA4<br>1: PA5<br>2: PB11<br>3: PB12 | 4: PB13<br>5: PB14<br>6: PB15<br>7: PC6  | 8: PC7<br>9: PC8<br>10: PC9<br>11: PC10   | 12: PC11<br>13: PD9<br>14: PD10<br>15: PD11 | 16: PD12<br>17: PD13<br>18: PD14<br>19: PD15 | 20: PF0<br>21: PF1<br>22: PF2<br>23: PF3     | 24: PF4<br>25: PF5<br>26: PF6<br>27: PF7 | 28: PA0<br>29: PA1<br>30: PA2<br>31: PA3 | MODEM antenna control output 1, used for antenna diversity.   |

| Alternate     | LOCATION                                 |  |   |  |  |  |  |  |  |
|---------------|--|--|---|--|--|--|--|--|--|
| Functionality | 0 - 3                                    | 4 - 7                                    | 8 - 11                                    | 12 - 15                                      | 16 - 19                                      | 20 - 23                                      | 24 - 27                                  | 28 - 31                                  | Description                              |
| MODEM_DCLK    | 0: PA0<br>1: PA1<br>2: PA2<br>3: PA3     | 4: PA4<br>5: PA5<br>6: PB11<br>7: PB12   | 8: PB13<br>9: PB14<br>10: PB15<br>11: PC6 | 12: PC7<br>13: PC8<br>14: PC9<br>15: PC10    | 16: PC11<br>17: PD9<br>18: PD10<br>19: PD11  | 20: PD12<br>21: PD13<br>22: PD14<br>23: PD15 | 24: PF0<br>25: PF1<br>26: PF2<br>27: PF3 | 28: PF4<br>29: PF5<br>30: PF6<br>31: PF7 | MODEM data clock out.                    |
| MODEM_DIN     | 0: PA1<br>1: PA2<br>2: PA3<br>3: PA4     | 4: PA5<br>5: PB11<br>6: PB12<br>7: PB13  | 8: PB14<br>9: PB15<br>10: PC6<br>11: PC7  | 12: PC8<br>13: PC9<br>14: PC10<br>15: PC11   | 16: PD9<br>17: PD10<br>18: PD11<br>19: PD12  | 20: PD13<br>21: PD14<br>22: PD15<br>23: PF0  | 24: PF1<br>25: PF2<br>26: PF3<br>27: PF4 | 28: PF5<br>29: PF6<br>30: PF7<br>31: PA0 | MODEM data in.                           |
| MODEM_DOUT    | 0: PA2<br>1: PA3<br>2: PA4<br>3: PA5     | 4: PB11<br>5: PB12<br>6: PB13<br>7: PB14 | 8: PB15<br>9: PC6<br>10: PC7<br>11: PC8   | 12: PC9<br>13: PC10<br>14: PC11<br>15: PD9   | 16: PD10<br>17: PD11<br>18: PD12<br>19: PD13 | 20: PD14<br>21: PD15<br>22: PF0<br>23: PF1   | 24: PF2<br>25: PF3<br>26: PF4<br>27: PF5 | 28: PF6<br>29: PF7<br>30: PA0<br>31: PA1 | MODEM data out.                          |
| PCNT0_S0IN    | 0: PA0<br>1: PA1<br>2: PA2<br>3: PA3     | 4: PA4<br>5: PA5<br>6: PB11<br>7: PB12   | 8: PB13<br>9: PB14<br>10: PB15<br>11: PC6 | 12: PC7<br>13: PC8<br>14: PC9<br>15: PC10    | 16: PC11<br>17: PD9<br>18: PD10<br>19: PD11  | 20: PD12<br>21: PD13<br>22: PD14<br>23: PD15 | 24: PF0<br>25: PF1<br>26: PF2<br>27: PF3 | 28: PF4<br>29: PF5<br>30: PF6<br>31: PF7 | Pulse Counter PCNT0 input number 0.      |
| PCNT0_S1IN    | 0: PA1<br>1: PA2<br>2: PA3<br>3: PA4     | 4: PA5<br>5: PB11<br>6: PB12<br>7: PB13  | 8: PB14<br>9: PB15<br>10: PC6<br>11: PC7  | 12: PC8<br>13: PC9<br>14: PC10<br>15: PC11   | 16: PD9<br>17: PD10<br>18: PD11<br>19: PD12  | 20: PD13<br>21: PD14<br>22: PD15<br>23: PF0  | 24: PF1<br>25: PF2<br>26: PF3<br>27: PF4 | 28: PF5<br>29: PF6<br>30: PF7<br>31: PA0 | Pulse Counter PCNT0 input number 1.      |
| PRS_CH0       | 0: PF0<br>1: PF1<br>2: PF2<br>3: PF3     | 4: PF4<br>5: PF5<br>6: PF6<br>7: PF7     | 8: PC6<br>9: PC7<br>10: PC8<br>11: PC9    | 12: PC10<br>13: PC11                         |  |  |  |  | Peripheral Reflex System PRS, channel 0. |
| PRS_CH1       | 0: PF1<br>1: PF2<br>2: PF3<br>3: PF4     | 4: PF5<br>5: PF6<br>6: PF7<br>7: PF0     |   |  |  |  |  |  | Peripheral Reflex System PRS, channel 1. |
| PRS_CH2       | 0: PF2<br>1: PF3<br>2: PF4<br>3: PF5     | 4: PF6<br>5: PF7<br>6: PF0<br>7: PF1     |   |  |  |  |  |  | Peripheral Reflex System PRS, channel 2. |
| PRS_CH3       | 0: PF3<br>1: PF4<br>2: PF5<br>3: PF6     | 4: PF7<br>5: PF0<br>6: PF1<br>7: PF2     | 8: PD9<br>9: PD10<br>10: PD11<br>11: PD12 | 12: PD13<br>13: PD14<br>14: PD15             |  |  |  |  | Peripheral Reflex System PRS, channel 3. |
| PRS_CH4       | 0: PD9<br>1: PD10<br>2: PD11<br>3: PD12  | 4: PD13<br>5: PD14<br>6: PD15            |   |  |  |  |  |  | Peripheral Reflex System PRS, channel 4. |
| PRS_CH5       | 0: PD10<br>1: PD11<br>2: PD12<br>3: PD13 | 4: PD14<br>5: PD15<br>6: PD9             |   |  |  |  |  |  | Peripheral Reflex System PRS, channel 5. |
| PRS_CH6       | 0: PA0<br>1: PA1<br>2: PA2<br>3: PA3     | 4: PA4<br>5: PA5<br>6: PB11<br>7: PB12   | 8: PB13<br>9: PB14<br>10: PB15<br>11: PD9 | 12: PD10<br>13: PD11<br>14: PD12<br>15: PD13 | 16: PD14<br>17: PD15                         |  |  |  | Peripheral Reflex System PRS, channel 6. |
| PRS_CH7       | 0: PA1<br>1: PA2<br>2: PA3<br>3: PA4     | 4: PA5<br>5: PB11<br>6: PB12<br>7: PB13  | 8: PB14<br>9: PB15<br>10: PA0             |  |  |  |  |  | Peripheral Reflex System PRS, channel 7. |



| Alternate     | LOCATION                                |  |   |   |  |  |  |  |  |
|---------------|---|--|---|---|--|--|--|--|--|
| Functionality | 0 - 3                                   | 4 - 7                                    | 8 - 11                                    | 12 - 15                                     | 16 - 19                                      | 20 - 23                                      | 24 - 27                                  | 28 - 31                                  | Description  |
| PRS_CH8       | 0: PA2<br>1: PA3<br>2: PA4<br>3: PA5    | 4: PB11<br>5: PB12<br>6: PB13<br>7: PB14 | 8: PB15<br>9: PA0<br>10: PA1              |   |  |  |  |  | Peripheral Reflex System PRS, channel 8.             |
| PRS_CH9       | 0: PA3<br>1: PA4<br>2: PA5<br>3: PB11   | 4: PB12<br>5: PB13<br>6: PB14<br>7: PB15 | 8: PA0<br>9: PA1<br>10: PA2<br>11: PC6    | 12: PC7<br>13: PC8<br>14: PC9<br>15: PC10   | 16: PC11                                     |  |  |  | Peripheral Reflex System PRS, channel 9.             |
| PRS_CH10      | 0: PC6<br>1: PC7<br>2: PC8<br>3: PC9    | 4: PC10<br>5: PC11                       |   |   |  |  |  |  | Peripheral Reflex System PRS, channel 10.            |
| PRS_CH11      | 0: PC7<br>1: PC8<br>2: PC9<br>3: PC10   | 4: PC11<br>5: PC6                        |   |   |  |  |  |  | Peripheral Reflex System PRS, channel 11.            |
| TIM0_CC0      | 0: PA0<br>1: PA1<br>2: PA2<br>3: PA3    | 4: PA4<br>5: PA5<br>6: PB11<br>7: PB12   | 8: PB13<br>9: PB14<br>10: PB15<br>11: PC6 | 12: PC7<br>13: PC8<br>14: PC9<br>15: PC10   | 16: PC11<br>17: PD9<br>18: PD10<br>19: PD11  | 20: PD12<br>21: PD13<br>22: PD14<br>23: PD15 | 24: PF0<br>25: PF1<br>26: PF2<br>27: PF3 | 28: PF4<br>29: PF5<br>30: PF6<br>31: PF7 | Timer 0 Capture Compare input / output channel 0.    |
| TIM0_CC1      | 0: PA1<br>1: PA2<br>2: PA3<br>3: PA4    | 4: PA5<br>5: PB11<br>6: PB12<br>7: PB13  | 8: PB14<br>9: PB15<br>10: PC6<br>11: PC7  | 12: PC8<br>13: PC9<br>14: PC10<br>15: PC11  | 16: PD9<br>17: PD10<br>18: PD11<br>19: PD12  | 20: PD13<br>21: PD14<br>22: PD15<br>23: PF0  | 24: PF1<br>25: PF2<br>26: PF3<br>27: PF4 | 28: PF5<br>29: PF6<br>30: PF7<br>31: PA0 | Timer 0 Capture Compare input / output channel 1.    |
| TIM0_CC2      | 0: PA2<br>1: PA3<br>2: PA4<br>3: PA5    | 4: PB11<br>5: PB12<br>6: PB13<br>7: PB14 | 8: PB15<br>9: PC6<br>10: PC7<br>11: PC8   | 12: PC9<br>13: PC10<br>14: PC11<br>15: PD9  | 16: PD10<br>17: PD11<br>18: PD12<br>19: PD13 | 20: PD14<br>21: PD15<br>22: PF0<br>23: PF1   | 24: PF2<br>25: PF3<br>26: PF4<br>27: PF5 | 28: PF6<br>29: PF7<br>30: PA0<br>31: PA1 | Timer 0 Capture Compare input / output channel 2.    |
| TIM0_CDT10    | 0: PA3<br>1: PA4<br>2: PA5<br>3: PB11   | 4: PB12<br>5: PB13<br>6: PB14<br>7: PB15 | 8: PC6<br>9: PC7<br>10: PC8<br>11: PC9    | 12: PC10<br>13: PC11<br>14: PD9<br>15: PD10 | 16: PD11<br>17: PD12<br>18: PD13<br>19: PD14 | 20: PD15<br>21: PF0<br>22: PF1<br>23: PF2    | 24: PF3<br>25: PF4<br>26: PF5<br>27: PF6 | 28: PF7<br>29: PA0<br>30: PA1<br>31: PA2 | Timer 0 Complimentary Dead Time Insertion channel 0. |
| TIM0_CDT11    | 0: PA4<br>1: PA5<br>2: PB11<br>3: PB12  | 4: PB13<br>5: PB14<br>6: PB15<br>7: PC6  | 8: PC7<br>9: PC8<br>10: PC9<br>11: PC10   | 12: PC11<br>13: PD9<br>14: PD10<br>15: PD11 | 16: PD12<br>17: PD13<br>18: PD14<br>19: PD15 | 20: PF0<br>21: PF1<br>22: PF2<br>23: PF3     | 24: PF4<br>25: PF5<br>26: PF6<br>27: PF7 | 28: PA0<br>29: PA1<br>30: PA2<br>31: PA3 | Timer 0 Complimentary Dead Time Insertion channel 1. |
| TIM0_CDT12    | 0: PA5<br>1: PB11<br>2: PB12<br>3: PB13 | 4: PB14<br>5: PB15<br>6: PC6<br>7: PC7   | 8: PC8<br>9: PC9<br>10: PC10<br>11: PC11  | 12: PD9<br>13: PD10<br>14: PD11<br>15: PD12 | 16: PD13<br>17: PD14<br>18: PD15<br>19: PF0  | 20: PF1<br>21: PF2<br>22: PF3<br>23: PF4     | 24: PF5<br>25: PF6<br>26: PF7<br>27: PA0 | 28: PA1<br>29: PA2<br>30: PA3<br>31: PA4 | Timer 0 Complimentary Dead Time Insertion channel 2. |
| TIM1_CC0      | 0: PA0<br>1: PA1<br>2: PA2<br>3: PA3    | 4: PA4<br>5: PA5<br>6: PB11<br>7: PB12   | 8: PB13<br>9: PB14<br>10: PB15<br>11: PC6 | 12: PC7<br>13: PC8<br>14: PC9<br>15: PC10   | 16: PC11<br>17: PD9<br>18: PD10<br>19: PD11  | 20: PD12<br>21: PD13<br>22: PD14<br>23: PD15 | 24: PF0<br>25: PF1<br>26: PF2<br>27: PF3 | 28: PF4<br>29: PF5<br>30: PF6<br>31: PF7 | Timer 1 Capture Compare input / output channel 0.    |
| TIM1_CC1      | 0: PA1<br>1: PA2<br>2: PA3<br>3: PA4    | 4: PA5<br>5: PB11<br>6: PB12<br>7: PB13  | 8: PB14<br>9: PB15<br>10: PC6<br>11: PC7  | 12: PC8<br>13: PC9<br>14: PC10<br>15: PC11  | 16: PD9<br>17: PD10<br>18: PD11<br>19: PD12  | 20: PD13<br>21: PD14<br>22: PD15<br>23: PF0  | 24: PF1<br>25: PF2<br>26: PF3<br>27: PF4 | 28: PF5<br>29: PF6<br>30: PF7<br>31: PA0 | Timer 1 Capture Compare input / output channel 1.    |
| TIM1_CC2      | 0: PA2<br>1: PA3<br>2: PA4<br>3: PA5    | 4: PB11<br>5: PB12<br>6: PB13<br>7: PB14 | 8: PB15<br>9: PC6<br>10: PC7<br>11: PC8   | 12: PC9<br>13: PC10<br>14: PC11<br>15: PD9  | 16: PD10<br>17: PD11<br>18: PD12<br>19: PD13 | 20: PD14<br>21: PD15<br>22: PF0<br>23: PF1   | 24: PF2<br>25: PF3<br>26: PF4<br>27: PF5 | 28: PF6<br>29: PF7<br>30: PA0<br>31: PA1 | Timer 1 Capture Compare input / output channel 2.    |

| Alternate     | LOCATION                                |  |   |   |  |  |  |  |   |
|---------------|---|--|---|---|--|--|--|--|---|
| Functionality | 0 - 3                                   | 4 - 7                                    | 8 - 11                                    | 12 - 15                                     | 16 - 19                                      | 20 - 23                                      | 24 - 27                                  | 28 - 31                                  | Description   |
| TIM1_CC3      | 0: PA3<br>1: PA4<br>2: PA5<br>3: PB11   | 4: PB12<br>5: PB13<br>6: PB14<br>7: PB15 | 8: PC6<br>9: PC7<br>10: PC8<br>11: PC9    | 12: PC10<br>13: PC11<br>14: PD9<br>15: PD10 | 16: PD11<br>17: PD12<br>18: PD13<br>19: PD14 | 20: PD15<br>21: PF0<br>22: PF1<br>23: PF2    | 24: PF3<br>25: PF4<br>26: PF5<br>27: PF6 | 28: PF7<br>29: PA0<br>30: PA1<br>31: PA2 | Timer 1 Capture Compare input / output channel 3.   |
| US0_CLK       | 0: PA2<br>1: PA3<br>2: PA4<br>3: PA5    | 4: PB11<br>5: PB12<br>6: PB13<br>7: PB14 | 8: PB15<br>9: PC6<br>10: PC7<br>11: PC8   | 12: PC9<br>13: PC10<br>14: PC11<br>15: PD9  | 16: PD10<br>17: PD11<br>18: PD12<br>19: PD13 | 20: PD14<br>21: PD15<br>22: PF0<br>23: PF1   | 24: PF2<br>25: PF3<br>26: PF4<br>27: PF5 | 28: PF6<br>29: PF7<br>30: PA0<br>31: PA1 | USART0 clock input / output.  |
| US0_CS        | 0: PA3<br>1: PA4<br>2: PA5<br>3: PB11   | 4: PB12<br>5: PB13<br>6: PB14<br>7: PB15 | 8: PC6<br>9: PC7<br>10: PC8<br>11: PC9    | 12: PC10<br>13: PC11<br>14: PD9<br>15: PD10 | 16: PD11<br>17: PD12<br>18: PD13<br>19: PD14 | 20: PD15<br>21: PF0<br>22: PF1<br>23: PF2    | 24: PF3<br>25: PF4<br>26: PF5<br>27: PF6 | 28: PF7<br>29: PA0<br>30: PA1<br>31: PA2 | USART0 chip select input / output.  |
| US0_CTS       | 0: PA4<br>1: PA5<br>2: PB11<br>3: PB12  | 4: PB13<br>5: PB14<br>6: PB15<br>7: PC6  | 8: PC7<br>9: PC8<br>10: PC9<br>11: PC10   | 12: PC11<br>13: PD9<br>14: PD10<br>15: PD11 | 16: PD12<br>17: PD13<br>18: PD14<br>19: PD15 | 20: PF0<br>21: PF1<br>22: PF2<br>23: PF3     | 24: PF4<br>25: PF5<br>26: PF6<br>27: PF7 | 28: PA0<br>29: PA1<br>30: PA2<br>31: PA3 | USART0 Clear To Send hardware flow control input.   |
| US0_RTS       | 0: PA5<br>1: PB11<br>2: PB12<br>3: PB13 | 4: PB14<br>5: PB15<br>6: PC6<br>7: PC7   | 8: PC8<br>9: PC9<br>10: PC10<br>11: PC11  | 12: PD9<br>13: PD10<br>14: PD11<br>15: PD12 | 16: PD13<br>17: PD14<br>18: PD15<br>19: PF0  | 20: PF1<br>21: PF2<br>22: PF3<br>23: PF4     | 24: PF5<br>25: PF6<br>26: PF7<br>27: PA0 | 28: PA1<br>29: PA2<br>30: PA3<br>31: PA4 | USART0 Request To Send hardware flow control output.  |
| US0_RX        | 0: PA1<br>1: PA2<br>2: PA3<br>3: PA4    | 4: PA5<br>5: PB11<br>6: PB12<br>7: PB13  | 8: PB14<br>9: PB15<br>10: PC6<br>11: PC7  | 12: PC8<br>13: PC9<br>14: PC10<br>15: PC11  | 16: PD9<br>17: PD10<br>18: PD11<br>19: PD12  | 20: PD13<br>21: PD14<br>22: PD15<br>23: PF0  | 24: PF1<br>25: PF2<br>26: PF3<br>27: PF4 | 28: PF5<br>29: PF6<br>30: PF7<br>31: PA0 | USART0 Asynchronous Receive.<br><br>USART0 Synchronous mode Master Input / Slave Output (MISO).   |
| US0_TX        | 0: PA0<br>1: PA1<br>2: PA2<br>3: PA3    | 4: PA4<br>5: PA5<br>6: PB11<br>7: PB12   | 8: PB13<br>9: PB14<br>10: PB15<br>11: PC6 | 12: PC7<br>13: PC8<br>14: PC9<br>15: PC10   | 16: PC11<br>17: PD9<br>18: PD10<br>19: PD11  | 20: PD12<br>21: PD13<br>22: PD14<br>23: PD15 | 24: PF0<br>25: PF1<br>26: PF2<br>27: PF3 | 28: PF4<br>29: PF5<br>30: PF6<br>31: PF7 | USART0 Asynchronous Transmit. Also used as receive input in half duplex communication.<br><br>USART0 Synchronous mode Master Output / Slave Input (MOSI). |
| US1_CLK       | 0: PA2<br>1: PA3<br>2: PA4<br>3: PA5    | 4: PB11<br>5: PB12<br>6: PB13<br>7: PB14 | 8: PB15<br>9: PC6<br>10: PC7<br>11: PC8   | 12: PC9<br>13: PC10<br>14: PC11<br>15: PD9  | 16: PD10<br>17: PD11<br>18: PD12<br>19: PD13 | 20: PD14<br>21: PD15<br>22: PF0<br>23: PF1   | 24: PF2<br>25: PF3<br>26: PF4<br>27: PF5 | 28: PF6<br>29: PF7<br>30: PA0<br>31: PA1 | USART1 clock input / output.  |
| US1_CS        | 0: PA3<br>1: PA4<br>2: PA5<br>3: PB11   | 4: PB12<br>5: PB13<br>6: PB14<br>7: PB15 | 8: PC6<br>9: PC7<br>10: PC8<br>11: PC9    | 12: PC10<br>13: PC11<br>14: PD9<br>15: PD10 | 16: PD11<br>17: PD12<br>18: PD13<br>19: PD14 | 20: PD15<br>21: PF0<br>22: PF1<br>23: PF2    | 24: PF3<br>25: PF4<br>26: PF5<br>27: PF6 | 28: PF7<br>29: PA0<br>30: PA1<br>31: PA2 | USART1 chip select input / output.  |
| US1_CTS       | 0: PA4<br>1: PA5<br>2: PB11<br>3: PB12  | 4: PB13<br>5: PB14<br>6: PB15<br>7: PC6  | 8: PC7<br>9: PC8<br>10: PC9<br>11: PC10   | 12: PC11<br>13: PD9<br>14: PD10<br>15: PD11 | 16: PD12<br>17: PD13<br>18: PD14<br>19: PD15 | 20: PF0<br>21: PF1<br>22: PF2<br>23: PF3     | 24: PF4<br>25: PF5<br>26: PF6<br>27: PF7 | 28: PA0<br>29: PA1<br>30: PA2<br>31: PA3 | USART1 Clear To Send hardware flow control input.   |
| US1_RTS       | 0: PA5<br>1: PB11<br>2: PB12<br>3: PB13 | 4: PB14<br>5: PB15<br>6: PC6<br>7: PC7   | 8: PC8<br>9: PC9<br>10: PC10<br>11: PC11  | 12: PD9<br>13: PD10<br>14: PD11<br>15: PD12 | 16: PD13<br>17: PD14<br>18: PD15<br>19: PF0  | 20: PF1<br>21: PF2<br>22: PF3<br>23: PF4     | 24: PF5<br>25: PF6<br>26: PF7<br>27: PA0 | 28: PA1<br>29: PA2<br>30: PA3<br>31: PA4 | USART1 Request To Send hardware flow control output.  |

| Alternate     | LOCATION                             |   |   |  |   |  |  |  |   |
|---------------|--------------------------------------|---|---|--|---|--|--|--|---|
| Functionality | 0 - 3                                | 4 - 7                                   | 8 - 11                                    | 12 - 15                                    | 16 - 19                                     | 20 - 23                                      | 24 - 27                                  | 28 - 31                                  | Description   |
| US1_RX        | 0: PA1<br>1: PA2<br>2: PA3<br>3: PA4 | 4: PA5<br>5: PB11<br>6: PB12<br>7: PB13 | 8: PB14<br>9: PB15<br>10: PC6<br>11: PC7  | 12: PC8<br>13: PC9<br>14: PC10<br>15: PC11 | 16: PD9<br>17: PD10<br>18: PD11<br>19: PD12 | 20: PD13<br>21: PD14<br>22: PD15<br>23: PF0  | 24: PF1<br>25: PF2<br>26: PF3<br>27: PF4 | 28: PF5<br>29: PF6<br>30: PF7<br>31: PA0 | USART1 Asynchronous Receive.<br><br>USART1 Synchronous mode Master Input / Slave Output (MISO).   |
| US1_TX        | 0: PA0<br>1: PA1<br>2: PA2<br>3: PA3 | 4: PA4<br>5: PA5<br>6: PB11<br>7: PB12  | 8: PB13<br>9: PB14<br>10: PB15<br>11: PC6 | 12: PC7<br>13: PC8<br>14: PC9<br>15: PC10  | 16: PC11<br>17: PD9<br>18: PD10<br>19: PD11 | 20: PD12<br>21: PD13<br>22: PD14<br>23: PD15 | 24: PF0<br>25: PF1<br>26: PF2<br>27: PF3 | 28: PF4<br>29: PF5<br>30: PF6<br>31: PF7 | USART1 Asynchronous Transmit. Also used as receive input in half duplex communication.<br><br>USART1 Synchronous mode Master Output / Slave Input (MOSI). |

### 6.7 Analog Port (APORT)

The Analog Port (APORT) is an infrastructure used to connect chip pins with on-chip analog clients such as analog comparators, ADCs, and DACs. The APORT consists of wires, switches, and control needed to configurably implement the routes. Please see the device Reference Manual for a complete description.

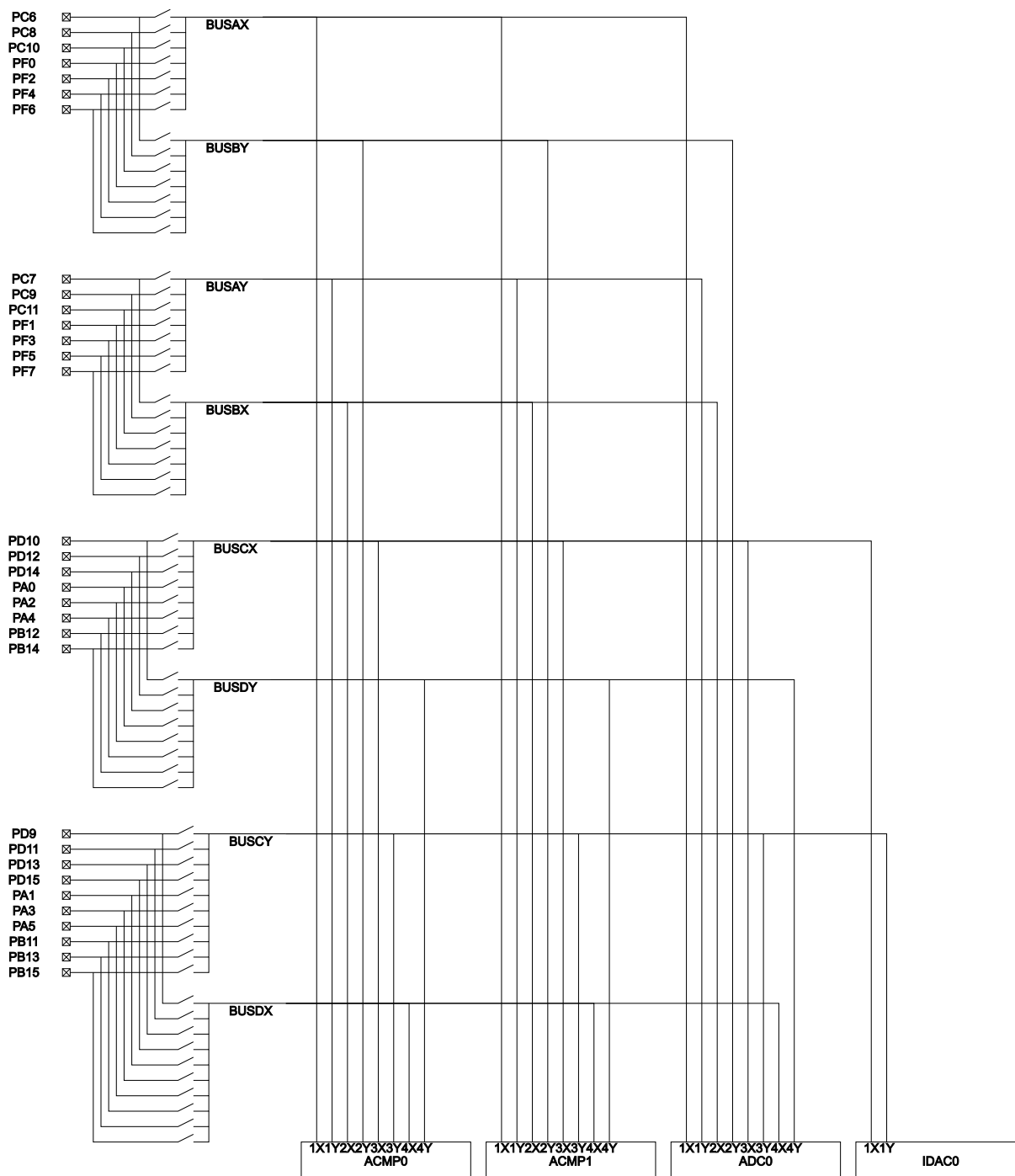


Figure 6.6. EFR32FG1 APORT

**Table 6.12. APORT Client Map**

| Analog Module | Analog Module Channel | Shared Bus | Pin  |
|---------------|-----------------------|------------|------|
| ACMP0         | APORT1XCH6            | BUSAX      | PC6  |
|               | APORT1XCH8            |            | PC8  |
|               | APORT1XCH10           |            | PC10 |
|               | APORT1XCH16           |            | PF0  |
|               | APORT1XCH18           |            | PF2  |
|               | APORT1XCH20           |            | PF4  |
|               | APORT1XCH22           |            | PF6  |
| ACMP0         | APORT1YCH7            | BUSAY      | PC7  |
|               | APORT1YCH9            |            | PC9  |
|               | APORT1YCH11           |            | PC11 |
|               | APORT1YCH17           |            | PF1  |
|               | APORT1YCH19           |            | PF3  |
|               | APORT1YCH21           |            | PF5  |
|               | APORT1YCH23           |            | PF7  |
| ACMP0         | APORT2XCH7            | BUSBX      | PC7  |
|               | APORT2XCH9            |            | PC9  |
|               | APORT2XCH11           |            | PC11 |
|               | APORT2XCH17           |            | PF1  |
|               | APORT2XCH19           |            | PF3  |
|               | APORT2XCH21           |            | PF5  |
|               | APORT2XCH23           |            | PF7  |
| ACMP0         | APORT2YCH6            | BUSBY      | PC6  |
|               | APORT2YCH8            |            | PC8  |
|               | APORT2YCH10           |            | PC10 |
|               | APORT2YCH16           |            | PF0  |
|               | APORT2YCH18           |            | PF2  |
|               | APORT2YCH20           |            | PF4  |
|               | APORT2YCH22           |            | PF6  |

| Analog Module | Analog Module Channel | Shared Bus | Pin  |
|---------------|-----------------------|------------|------|
| ACMP0         | APORT3XCH2            | BUSCX      | PD10 |
|               | APORT3XCH4            |            | PD12 |
|               | APORT3XCH6            |            | PD14 |
|               | APORT3XCH8            |            | PA0  |
|               | APORT3XCH10           |            | PA2  |
|               | APORT3XCH12           |            | PA4  |
|               | APORT3XCH28           |            | PB12 |
|               | APORT3XCH30           |            | PB14 |
| ACMP0         | APORT3YCH1            | BUSCY      | PD9  |
|               | APORT3YCH3            |            | PD11 |
|               | APORT3YCH5            |            | PD13 |
|               | APORT3YCH7            |            | PD15 |
|               | APORT3YCH9            |            | PA1  |
|               | APORT3YCH11           |            | PA3  |
|               | APORT3YCH13           |            | PA5  |
|               | APORT3YCH27           |            | PB11 |
|               | APORT3YCH29           |            | PB13 |
| APORT3YCH31   | PB15                  |            |      |
| ACMP0         | APORT4XCH1            | BUSDX      | PD9  |
|               | APORT4XCH3            |            | PD11 |
|               | APORT4XCH5            |            | PD13 |
|               | APORT4XCH7            |            | PD15 |
|               | APORT4XCH9            |            | PA1  |
|               | APORT4XCH11           |            | PA3  |
|               | APORT4XCH13           |            | PA5  |
|               | APORT4XCH27           |            | PB11 |
|               | APORT4XCH29           |            | PB13 |
|               | APORT4XCH31           |            | PB15 |
| ACMP0         | APORT4YCH2            | BUSDY      | PD10 |
|               | APORT4YCH4            |            | PD12 |
|               | APORT4YCH6            |            | PD14 |
|               | APORT4YCH8            |            | PA0  |
|               | APORT4YCH10           |            | PA2  |
|               | APORT4YCH12           |            | PA4  |
|               | APORT4YCH28           |            | PB12 |
|               | APORT4YCH30           |            | PB14 |

| Analog Module | Analog Module Channel | Shared Bus | Pin  |
|---------------|-----------------------|------------|------|
| ACMP1         | APORT1XCH6            | BUSAX      | PC6  |
|               | APORT1XCH8            |            | PC8  |
|               | APORT1XCH10           |            | PC10 |
|               | APORT1XCH16           |            | PF0  |
|               | APORT1XCH18           |            | PF2  |
|               | APORT1XCH20           |            | PF4  |
|               | APORT1XCH22           |            | PF6  |
| ACMP1         | APORT1YCH7            | BUSAY      | PC7  |
|               | APORT1YCH9            |            | PC9  |
|               | APORT1YCH11           |            | PC11 |
|               | APORT1YCH17           |            | PF1  |
|               | APORT1YCH19           |            | PF3  |
|               | APORT1YCH21           |            | PF5  |
|               | APORT1YCH23           |            | PF7  |
| ACMP1         | APORT2XCH7            | BUSBX      | PC7  |
|               | APORT2XCH9            |            | PC9  |
|               | APORT2XCH11           |            | PC11 |
|               | APORT2XCH17           |            | PF1  |
|               | APORT2XCH19           |            | PF3  |
|               | APORT2XCH21           |            | PF5  |
|               | APORT2XCH23           |            | PF7  |
| ACMP1         | APORT2YCH6            | BUSBY      | PC6  |
|               | APORT2YCH8            |            | PC8  |
|               | APORT2YCH10           |            | PC10 |
|               | APORT2YCH16           |            | PF0  |
|               | APORT2YCH18           |            | PF2  |
|               | APORT2YCH20           |            | PF4  |
|               | APORT2YCH22           |            | PF6  |
| ACMP1         | APORT3XCH2            | BUSCX      | PD10 |
|               | APORT3XCH4            |            | PD12 |
|               | APORT3XCH6            |            | PD14 |
|               | APORT3XCH8            |            | PA0  |
|               | APORT3XCH10           |            | PA2  |
|               | APORT3XCH12           |            | PA4  |
|               | APORT3XCH28           |            | PB12 |
|               | APORT3XCH30           |            | PB14 |

| Analog Module | Analog Module Channel | Shared Bus | Pin  |
|---------------|-----------------------|------------|------|
| ACMP1         | APORT3YCH1            | BUSCY      | PD9  |
|               | APORT3YCH3            |            | PD11 |
|               | APORT3YCH5            |            | PD13 |
|               | APORT3YCH7            |            | PD15 |
|               | APORT3YCH9            |            | PA1  |
|               | APORT3YCH11           |            | PA3  |
|               | APORT3YCH13           |            | PA5  |
|               | APORT3YCH27           |            | PB11 |
|               | APORT3YCH29           |            | PB13 |
|               | APORT3YCH31           |            | PB15 |
| ACMP1         | APORT4XCH1            | BUSDX      | PD9  |
|               | APORT4XCH3            |            | PD11 |
|               | APORT4XCH5            |            | PD13 |
|               | APORT4XCH7            |            | PD15 |
|               | APORT4XCH9            |            | PA1  |
|               | APORT4XCH11           |            | PA3  |
|               | APORT4XCH13           |            | PA5  |
|               | APORT4XCH27           |            | PB11 |
|               | APORT4XCH29           |            | PB13 |
|               | APORT4XCH31           |            | PB15 |
| ACMP1         | APORT4YCH2            | BUSDY      | PD10 |
|               | APORT4YCH4            |            | PD12 |
|               | APORT4YCH6            |            | PD14 |
|               | APORT4YCH8            |            | PA0  |
|               | APORT4YCH10           |            | PA2  |
|               | APORT4YCH12           |            | PA4  |
|               | APORT4YCH28           |            | PB12 |
|               | APORT4YCH30           |            | PB14 |
| ADC0          | APORT1XCH6            | BUSAX      | PC6  |
|               | APORT1XCH8            |            | PC8  |
|               | APORT1XCH10           |            | PC10 |
|               | APORT1XCH16           |            | PF0  |
|               | APORT1XCH18           |            | PF2  |
|               | APORT1XCH20           |            | PF4  |
|               | APORT1XCH22           |            | PF6  |



| Analog Module | Analog Module Channel | Shared Bus | Pin  |
|---------------|-----------------------|------------|------|
| ADC0          | APORT1YCH7            | BUSAY      | PC7  |
|               | APORT1YCH9            |            | PC9  |
|               | APORT1YCH11           |            | PC11 |
|               | APORT1YCH17           |            | PF1  |
|               | APORT1YCH19           |            | PF3  |
|               | APORT1YCH21           |            | PF5  |
|               | APORT1YCH23           |            | PF7  |
| ADC0          | APORT2XCH7            | BUSBX      | PC7  |
|               | APORT2XCH9            |            | PC9  |
|               | APORT2XCH11           |            | PC11 |
|               | APORT2XCH17           |            | PF1  |
|               | APORT2XCH19           |            | PF3  |
|               | APORT2XCH21           |            | PF5  |
|               | APORT2XCH23           |            | PF7  |
| ADC0          | APORT2YCH6            | BUSBY      | PC6  |
|               | APORT2YCH8            |            | PC8  |
|               | APORT2YCH10           |            | PC10 |
|               | APORT2YCH16           |            | PF0  |
|               | APORT2YCH18           |            | PF2  |
|               | APORT2YCH20           |            | PF4  |
|               | APORT2YCH22           |            | PF6  |
| ADC0          | APORT3XCH2            | BUSCX      | PD10 |
|               | APORT3XCH4            |            | PD12 |
|               | APORT3XCH6            |            | PD14 |
|               | APORT3XCH8            |            | PA0  |
|               | APORT3XCH10           |            | PA2  |
|               | APORT3XCH12           |            | PA4  |
|               | APORT3XCH28           |            | PB12 |
|               | APORT3XCH30           |            | PB14 |

| Analog Module | Analog Module Channel | Shared Bus | Pin  |
|---------------|-----------------------|------------|------|
| ADC0          | APORT3YCH1            | BUSCY      | PD9  |
|               | APORT3YCH3            |            | PD11 |
|               | APORT3YCH5            |            | PD13 |
|               | APORT3YCH7            |            | PD15 |
|               | APORT3YCH9            |            | PA1  |
|               | APORT3YCH11           |            | PA3  |
|               | APORT3YCH13           |            | PA5  |
|               | APORT3YCH27           |            | PB11 |
|               | APORT3YCH29           |            | PB13 |
|               | APORT3YCH31           |            | PB15 |
| ADC0          | APORT4XCH1            | BUSDX      | PD9  |
|               | APORT4XCH3            |            | PD11 |
|               | APORT4XCH5            |            | PD13 |
|               | APORT4XCH7            |            | PD15 |
|               | APORT4XCH9            |            | PA1  |
|               | APORT4XCH11           |            | PA3  |
|               | APORT4XCH13           |            | PA5  |
|               | APORT4XCH27           |            | PB11 |
|               | APORT4XCH29           |            | PB13 |
|               | APORT4XCH31           |            | PB15 |
| ADC0          | APORT4YCH2            | BUSDY      | PD10 |
|               | APORT4YCH4            |            | PD12 |
|               | APORT4YCH6            |            | PD14 |
|               | APORT4YCH8            |            | PA0  |
|               | APORT4YCH10           |            | PA2  |
|               | APORT4YCH12           |            | PA4  |
|               | APORT4YCH28           |            | PB12 |
|               | APORT4YCH30           |            | PB14 |
| IDAC0         | APORT1XCH2            | BUSCX      | PD10 |
|               | APORT1XCH4            |            | PD12 |
|               | APORT1XCH6            |            | PD14 |
|               | APORT1XCH8            |            | PA0  |
|               | APORT1XCH10           |            | PA2  |
|               | APORT1XCH12           |            | PA4  |
|               | APORT1XCH28           |            | PB12 |
|               | APORT1XCH30           |            | PB14 |

| Analog Module | Analog Module Channel | Shared Bus | Pin  |
|---------------|-----------------------|------------|------|
| IDAC0         | APORT1YCH1            | BUSCY      | PD9  |
|               | APORT1YCH3            |            | PD11 |
|               | APORT1YCH5            |            | PD13 |
|               | APORT1YCH7            |            | PD15 |
|               | APORT1YCH9            |            | PA1  |
|               | APORT1YCH11           |            | PA3  |
|               | APORT1YCH13           |            | PA5  |
|               | APORT1YCH27           |            | PB11 |
|               | APORT1YCH29           |            | PB13 |
|               | APORT1YCH31           |            | PB15 |

## 7. QFN48 Package Specifications

### 7.1 QFN48 Package Dimensions

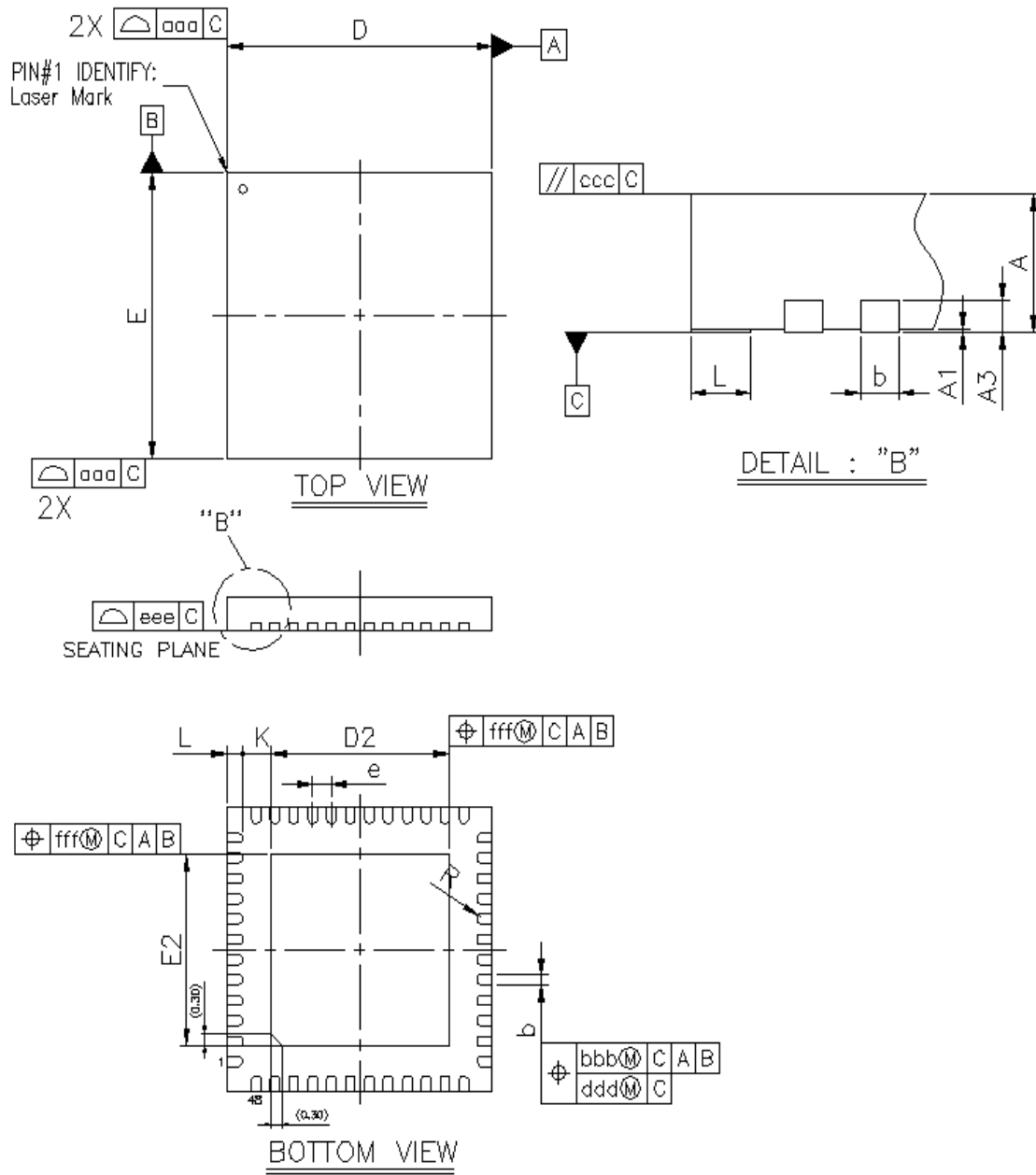


Figure 7.1. QFN48 Package Drawing

**Table 7.1. QFN48 Package Dimensions**

| Dimension | Min      | Typ  | Max  |
|-----------|----------|------|------|
| A         | 0.80     | 0.85 | 0.90 |
| A1        | 0.00     | 0.02 | 0.05 |
| A3        | 0.20 REF |      |      |
| b         | 0.18     | 0.25 | 0.30 |
| D         | 6.90     | 7.00 | 7.10 |
| E         | 6.90     | 7.00 | 7.10 |
| D2        | 4.60     | 4.70 | 4.80 |
| E2        | 4.60     | 4.70 | 4.80 |
| e         | 0.50 BSC |      |      |
| L         | 0.30     | 0.40 | 0.50 |
| K         | 0.20     | —    | —    |
| R         | 0.09     | —    | 0.14 |
| aaa       | 0.15     |      |      |
| bbb       | 0.10     |      |      |
| ccc       | 0.10     |      |      |
| ddd       | 0.05     |      |      |
| eee       | 0.08     |      |      |
| fff       | 0.10     |      |      |

**Note:**

1. All dimensions shown are in millimeters (mm) unless otherwise noted.
2. Dimensioning and Tolerancing per ANSI Y14.5M-1994.
3. This drawing conforms to the JEDEC Solid State Outline MO-220, Variation VKKD-4.
4. Recommended card reflow profile is per the JEDEC/IPC J-STD-020 specification for Small Body Components.

## 7.2 QFN48 PCB Land Pattern

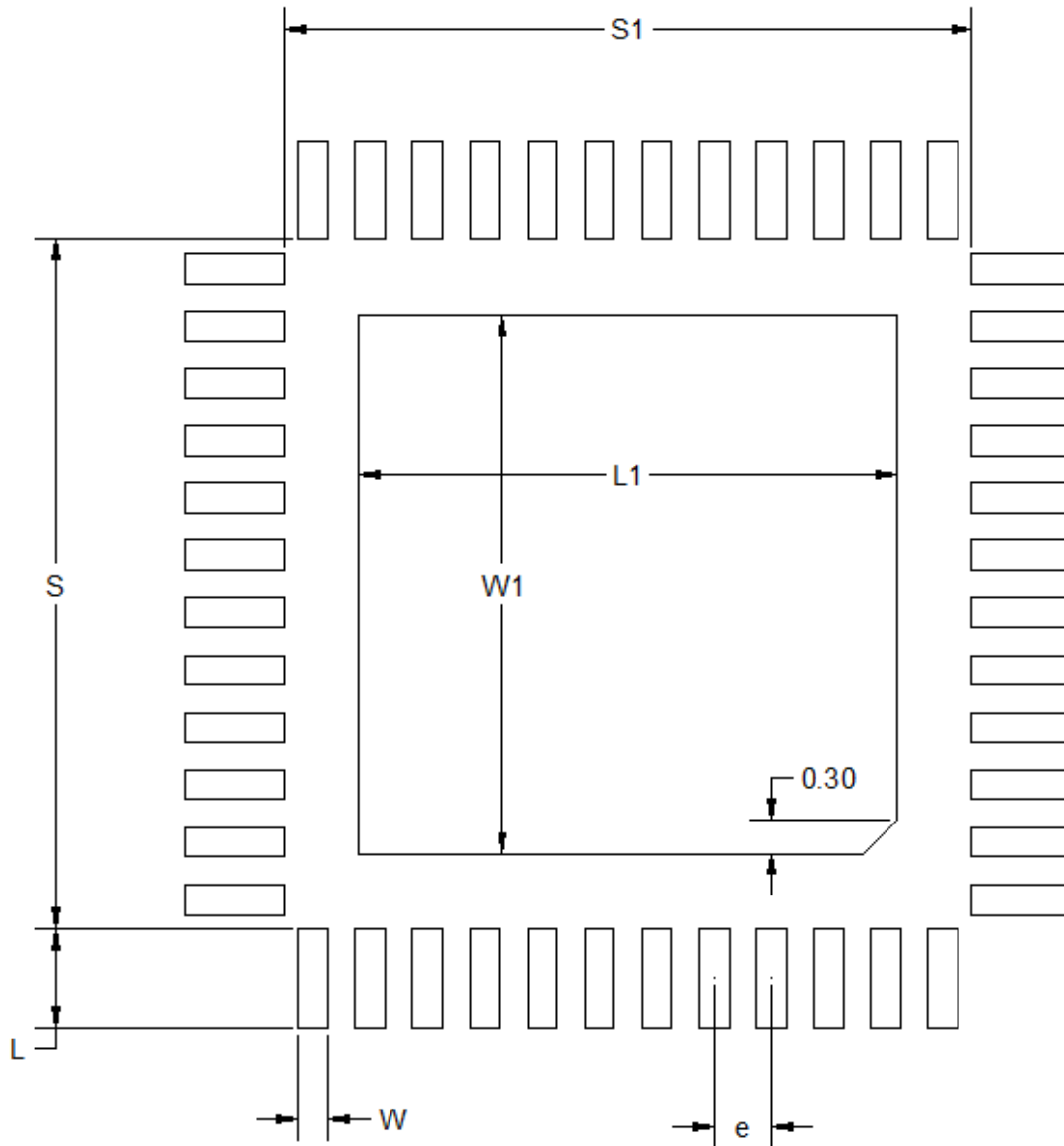


Figure 7.2. QFN48 PCB Land Pattern Drawing

**Table 7.2. QFN48 PCB Land Pattern Dimensions**

| Dimension | Typ  |
|-----------|------|
| S1        | 6.01 |
| S         | 6.01 |
| L1        | 4.70 |
| W1        | 4.70 |
| e         | 0.50 |
| W         | 0.26 |
| L         | 0.86 |

**Note:**

1. All dimensions shown are in millimeters (mm) unless otherwise noted.
2. This Land Pattern Design is based on the IPC-7351 guidelines.
3. All metal pads are to be non-solder mask defined (NSMD). Clearance between the solder mask and the metal pad is to be 60  $\mu$ m minimum, all the way around the pad.
4. A stainless steel, laser-cut and electro-polished stencil with trapezoidal walls should be used to assure good solder paste release.
5. The stencil thickness should be 0.125 mm (5 mils).
6. The ratio of stencil aperture to land pad size can be 1:1 for all perimeter pads.
7. A 4x4 array of 0.75 mm square openings on a 1.00 mm pitch can be used for the center ground pad.
8. A No-Clean, Type-3 solder paste is recommended.
9. The recommended card reflow profile is per the JEDEC/IPC J-STD-020 specification for Small Body Components.

### 7.3 QFN48 Package Marking

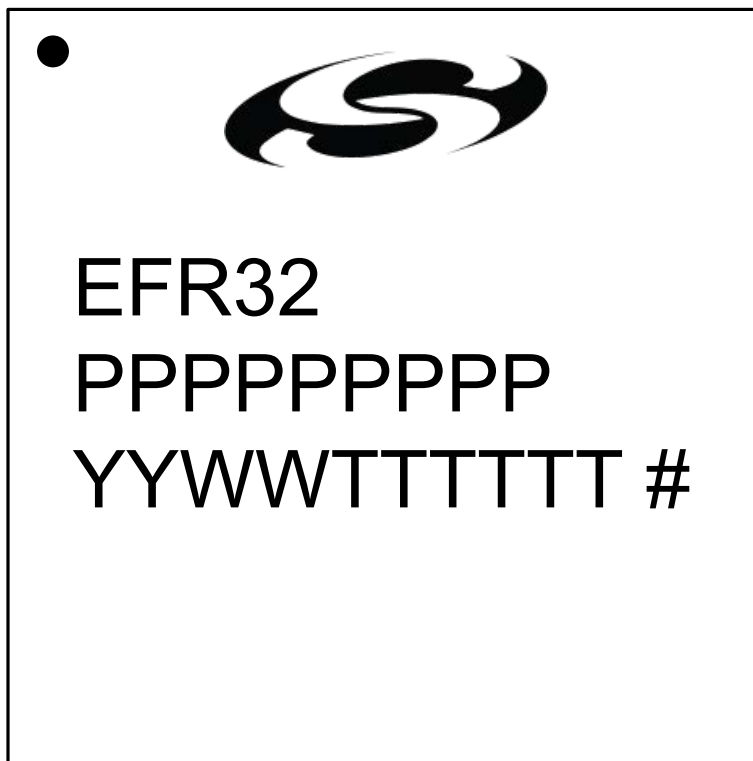


Figure 7.3. QFN48 Package Marking

The package marking consists of:

- P P P P P P P P P P – The part number designation.
  1. Family Code (B | M | F)
  2. G (Gecko)
  3. Generation (1)
  4. Performance Grade (P | B | V)
  5. Feature Code (1 to 7)
  6. TRX Code (3 = TXRX | 2= RX | 1 = TX)
  7. Band (1 = Sub-GHz | 2 = 2.4 GHz | 3 = Dual-band)
  8. Flash (G = 256K | F = 128K | E = 64K | D = 32K)
  9. Temperature Grade (G = -40 to 85 | I = -40 to 125)
- YY – The last 2 digits of the assembly year.
- WW – The 2-digit workweek when the device was assembled.
- TTTT – A trace or manufacturing code. The first letter is the device revision.
- # – Bootloader revision number.



## 8. QFN32 Package Specifications

### 8.1 QFN32 Package Dimensions

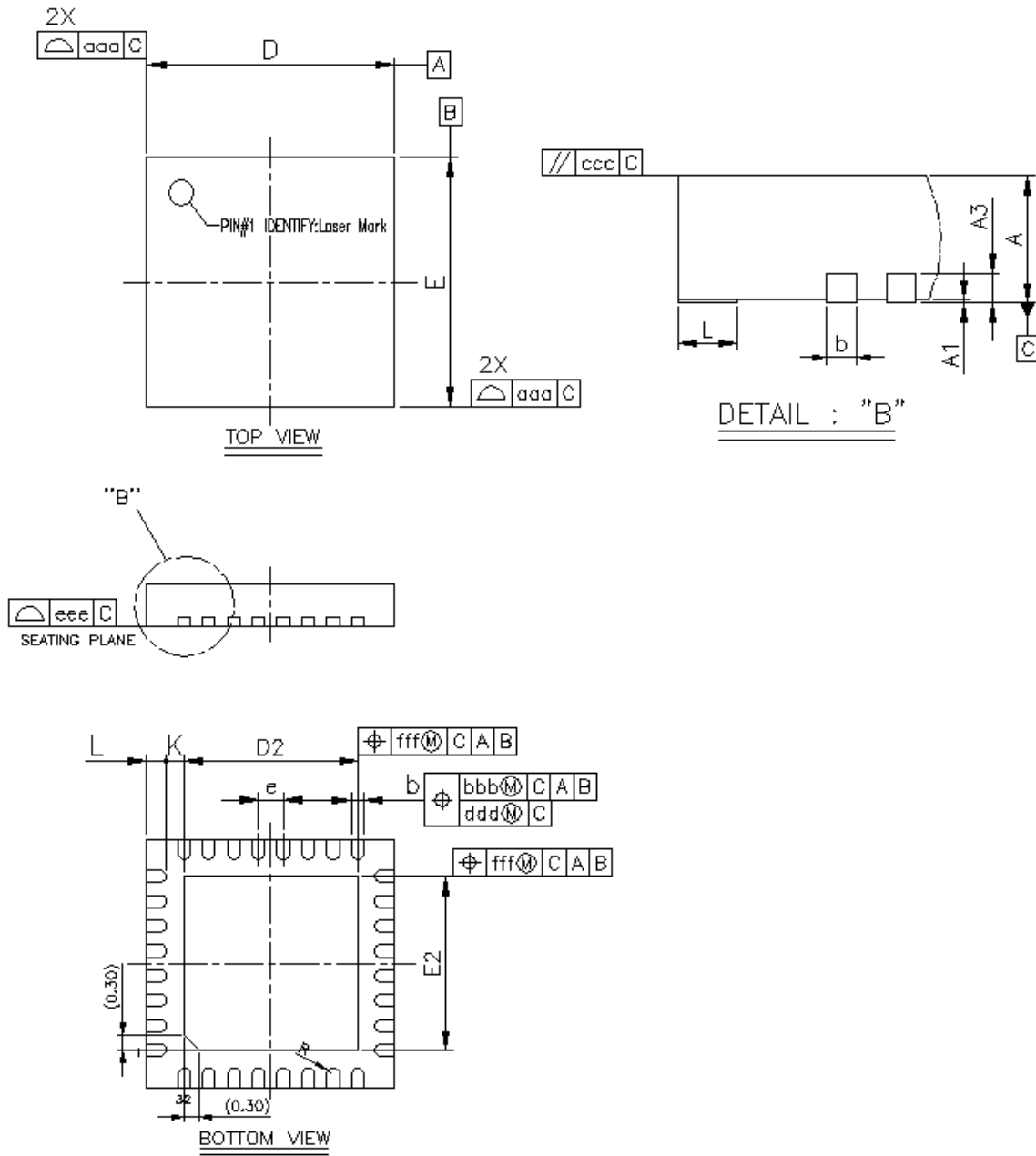


Figure 8.1. QFN32 Package Drawing

**Table 8.1. QFN32 Package Dimensions**

| Dimension | Min      | Typ  | Max  |
|-----------|----------|------|------|
| A         | 0.80     | 0.85 | 0.90 |
| A1        | 0.00     | 0.02 | 0.05 |
| A3        | 0.20 REF |      |      |
| b         | 0.18     | 0.25 | 0.30 |
| D/E       | 4.90     | 5.00 | 5.10 |
| D2/E2     | 3.40     | 3.50 | 3.60 |
| E         | 0.50 BSC |      |      |
| L         | 0.30     | 0.40 | 0.50 |
| K         | 0.20     | —    | —    |
| R         | 0.09     | —    | 0.14 |
| aaa       | 0.15     |      |      |
| bbb       | 0.10     |      |      |
| ccc       | 0.10     |      |      |
| ddd       | 0.05     |      |      |
| eee       | 0.08     |      |      |
| fff       | 0.10     |      |      |

**Note:**

1. All dimensions shown are in millimeters (mm) unless otherwise noted.
2. Dimensioning and Tolerancing per ANSI Y14.5M-1994.
3. This drawing conforms to the JEDEC Solid State Outline MO-220, Variation VKKD-4.
4. Recommended card reflow profile is per the JEDEC/IPC J-STD-020 specification for Small Body Components.

## 8.2 QFN32 PCB Land Pattern

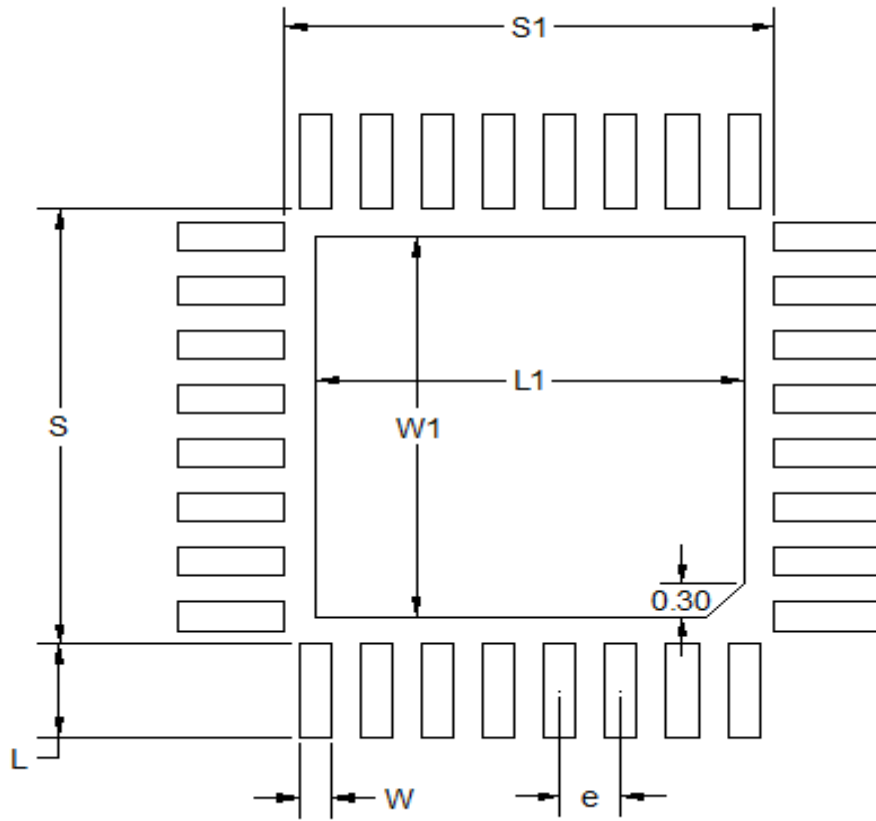


Figure 8.2. QFN32 PCB Land Pattern Drawing

**Table 8.2. QFN32 PCB Land Pattern Dimensions**

| Dimension | Typ  |
|-----------|------|
| S1        | 4.01 |
| S         | 4.01 |
| L1        | 3.50 |
| W1        | 3.50 |
| e         | 0.50 |
| W         | 0.26 |
| L         | 0.86 |

**Note:**

1. All dimensions shown are in millimeters (mm) unless otherwise noted.
2. This Land Pattern Design is based on the IPC-7351 guidelines.
3. All metal pads are to be non-solder mask defined (NSMD). Clearance between the solder mask and the metal pad is to be 60  $\mu$ m minimum, all the way around the pad.
4. A stainless steel, laser-cut and electro-polished stencil with trapezoidal walls should be used to assure good solder paste release.
5. The stencil thickness should be 0.125 mm (5 mils).
6. The ratio of stencil aperture to land pad size can be 1:1 for all perimeter pads.
7. A 3x3 array of 0.85 mm square openings on a 1.00 mm pitch can be used for the center ground pad.
8. A No-Clean, Type-3 solder paste is recommended.
9. The recommended card reflow profile is per the JEDEC/IPC J-STD-020 specification for Small Body Components.

### 8.3 QFN32 Package Marking



**Figure 8.3. QFN32 Package Marking**

The package marking consists of:

- P P P P P P P P P P – The part number designation.
  1. Family Code (B | M | F)
  2. G (Gecko)
  3. Generation (1)
  4. Performance Grade (P | B | V)
  5. Feature Code (1 to 7)
  6. TRX Code (3 = TXRX | 2= RX | 1 = TX)
  7. Band (1 = Sub-GHz | 2 = 2.4 GHz | 3 = Dual-band)
  8. Flash (G = 256K | F = 128K | E = 64K | D = 32K)
  9. Temperature Grade (G = -40 to 85 | I = -40 to 125)
- YY – The last 2 digits of the assembly year.
- WW – The 2-digit workweek when the device was assembled.
- T T T T T T – A trace or manufacturing code. The first letter is the device revision.

## 9. Revision History

### 9.1 Revision 0.97

2016-06-06

- Added dual-band and sub-GHz OPNs.

### 9.2 Revision 0.951

2016-06-03

- Electrical specification tables updated with additional characterization data.

### 9.3 Revision 0.95

2016-04-11

- All OPNs changed to rev C0. Note the following:
  - All OPNs ending in -B0 are Engineering Samples based on an older revision of silicon and are being removed from the OPN table. These older revisions should be used for evaluation only and will not be supported for production.
  - OPNs ending in -C0 are the Current Revision of Silicon and are intended for production.
- Electrical specification tables updated with latest characterization data and production test limits.

### 9.4 Revision 0.9

2016-01-12

- Updated electrical specifications with latest characterization data.
- Added thermal characteristics table.
- Updated OPN decoder figure to include extended family options.

### 9.5 Revision 0.81

2015-12-01

- Engineering samples note added to ordering information table.

### 9.6 Revision 0.8

2015-11-14

- Initial external release.
- Consolidated individual device datasheets into single-family document.
- Re-formatted ordering information table and OPN decoder.
- Updated block diagrams for front page and system overview.
- Removed extraneous sections from DC-DC and wake-on-radio from system overview.
- Updated table formatting for electrical specifications to tech pubs standards.
- Updated electrical specifications with latest available data.
- Added I2C and USART SPI timing tables.
- Moved DC-DC graph to typical performance curves.
- Updated APORT tables and APORT references to correct nomenclature.

---

# Table of Contents

|   |          |
|---|----------|
| <b>1. Feature List</b>  | <b>1</b> |
| <b>2. Ordering Information</b>  | <b>2</b> |
| <b>3. System Overview</b>   | <b>4</b> |
| 3.1 Introduction  | 4        |
| 3.2 Radio   | 4        |
| 3.2.1 Antenna Interface   | 5        |
| 3.2.2 Fractional-N Frequency Synthesizer                              | 5        |
| 3.2.3 Receiver Architecture   | 5        |
| 3.2.4 Transmitter Architecture  | 5        |
| 3.2.5 Wake on Radio   | 5        |
| 3.2.6 RFSENSE   | 6        |
| 3.2.7 Flexible Frame Handling   | 6        |
| 3.2.8 Packet and State Trace  | 6        |
| 3.2.9 Data Buffering  | 6        |
| 3.2.10 Radio Controller (RAC)   | 6        |
| 3.2.11 Random Number Generator  | 7        |
| 3.3 Power   | 8        |
| 3.3.1 Energy Management Unit (EMU)                                    | 8        |
| 3.3.2 DC-DC Converter   | 8        |
| 3.4 General Purpose Input/Output (GPIO)                               | 8        |
| 3.5 Clocking  | 8        |
| 3.5.1 Clock Management Unit (CMU)                                     | 8        |
| 3.5.2 Internal and External Oscillators                               | 8        |
| 3.6 Counters/Timers and PWM   | 9        |
| 3.6.1 Timer/Counter (TIMER)   | 9        |
| 3.6.2 Real Time Counter and Calendar (RTCC)                           | 9        |
| 3.6.3 Low Energy Timer (LETIMER)                                      | 9        |
| 3.6.4 Ultra Low Power Wake-up Timer (CRYOTIMER)                       | 9        |
| 3.6.5 Pulse Counter (PCNT)  | 9        |
| 3.6.6 Watchdog Timer (WDOG)   | 9        |
| 3.7 Communications and Other Digital Peripherals                      | 9        |
| 3.7.1 Universal Synchronous/Asynchronous Receiver/Transmitter (USART) | 9        |
| 3.7.2 Low Energy Universal Asynchronous Receiver/Transmitter (LEUART) | 10       |
| 3.7.3 Inter-Integrated Circuit Interface (I <sup>2</sup> C)           | 10       |
| 3.7.4 Peripheral Reflex System (PRS)                                  | 10       |
| 3.8 Security Features   | 10       |
| 3.8.1 GPCRC (General Purpose Cyclic Redundancy Check)                 | 10       |
| 3.8.2 Crypto Accelerator (CRYPTO)                                     | 10       |
| 3.9 Analog  | 10       |
| 3.9.1 Analog Port (APORT)   | 10       |
| 3.9.2 Analog Comparator (ACMP)  | 10       |
| 3.9.3 Analog to Digital Converter (ADC)                               | 11       |
| 3.9.4 Digital to Analog Current Converter (IDAC)                      | 11       |

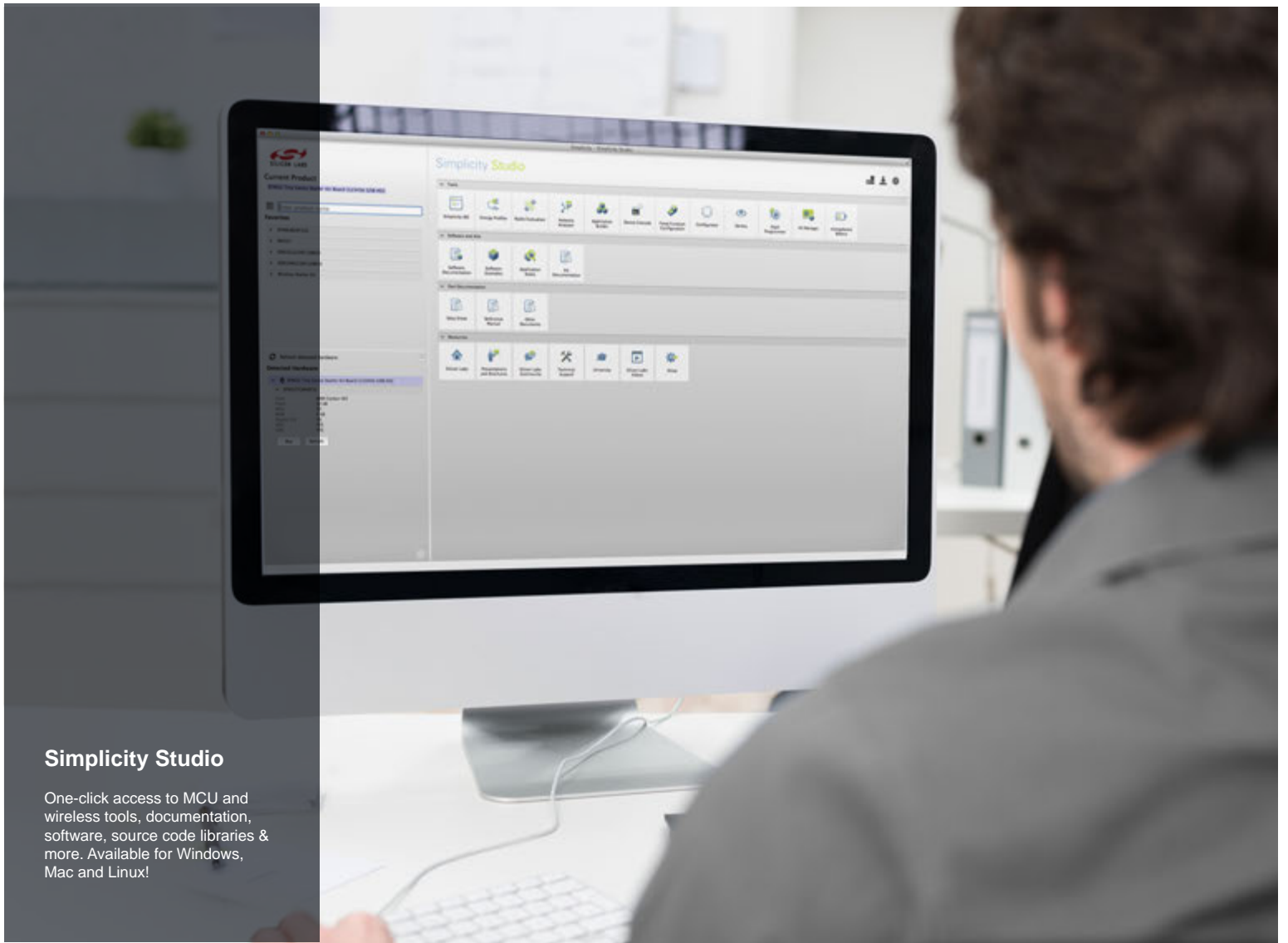
|           |   |           |
|-----------|---|-----------|
| 3.10      | Reset Management Unit (RMU)   | .11       |
| 3.11      | Core and Memory   | .11       |
| 3.11.1    | Processor Core  | .11       |
| 3.11.2    | Memory System Controller (MSC)  | .11       |
| 3.11.3    | Linked Direct Memory Access Controller (LDMA)                               | .11       |
| 3.12      | Memory Map  | .12       |
| 3.13      | Configuration Summary   | .13       |
| <b>4.</b> | <b>Electrical Specifications</b>  | <b>14</b> |
| 4.1       | Electrical Characteristics  | .14       |
| 4.1.1     | Absolute Maximum Ratings  | .15       |
| 4.1.2     | Operating Conditions  | .17       |
| 4.1.2.1   | General Operating Conditions  | .17       |
| 4.1.3     | Thermal Characteristics   | .18       |
| 4.1.4     | DC-DC Converter   | .19       |
| 4.1.5     | Current Consumption   | .21       |
| 4.1.5.1   | Current Consumption 3.3 V without DC-DC Converter                           | .21       |
| 4.1.5.2   | Current Consumption 3.3 V using DC-DC Converter                             | .22       |
| 4.1.5.3   | Current Consumption 1.85 V without DC-DC Converter                          | .24       |
| 4.1.5.4   | Current Consumption Using Radio   | .25       |
| 4.1.6     | Wake up times   | .27       |
| 4.1.7     | Brown Out Detector  | .27       |
| 4.1.8     | Frequency Synthesizer Characteristics                                       | .28       |
| 4.1.9     | 2.4 GHz RF Transceiver Characteristics                                      | .29       |
| 4.1.9.1   | RF Transmitter General Characteristics for the 2.4 GHz Band                 | .29       |
| 4.1.9.2   | RF Receiver General Characteristics for the 2.4 GHz Band                    | .30       |
| 4.1.9.3   | RF Transmitter Characteristics for 1Mbps 2GFSK in the 2.4 GHz Band          | .31       |
| 4.1.9.4   | RF Receiver Characteristics for 1Mbps 2GFSK in the 2.4 GHz Band             | .32       |
| 4.1.9.5   | RF Transmitter Characteristics for 802.15.4 O-QPSK DSSS in the 2.4 GHz Band | .34       |
| 4.1.9.6   | RF Receiver Characteristics for 802.15.4 O-QPSK DSSS in the 2.4 GHz Band    | .36       |
| 4.1.10    | Sub-GHz RF Transceiver Characteristics                                      | .38       |
| 4.1.10.1  | Sub-GHz RF Transmitter Characteristics in the 915 MHz Band                  | .39       |
| 4.1.10.2  | Sub-GHz RF Receiver Characteristics in the 915 MHz Band                     | .42       |
| 4.1.10.3  | Sub-GHz RF Transmitter Characteristics in the 868 MHz Band                  | .45       |
| 4.1.10.4  | Sub-GHz RF Receiver Characteristics in the 868 MHz Band                     | .46       |
| 4.1.10.5  | Sub-GHz RF Transmitter Characteristics in the 490 MHz Band                  | .48       |
| 4.1.10.6  | Sub-GHz RF Receiver Characteristics in the 490 MHz Band                     | .49       |
| 4.1.10.7  | Sub-GHz RF Transmitter Characteristics in the 433 MHz Band                  | .51       |
| 4.1.10.8  | Sub-GHz RF Receiver Characteristics in the 433 MHz Band                     | .54       |
| 4.1.10.9  | Sub-GHz RF Transmitter Characteristics in the 315 MHz Band                  | .57       |
| 4.1.10.10 | Sub-GHz RF Receiver Characteristics in the 315 MHz Band                     | .59       |
| 4.1.10.11 | Sub-GHz RF Transmitter Characteristics in the 169 MHz Band                  | .61       |
| 4.1.10.12 | Sub-GHz RF Receiver Characteristics in the 169 MHz Band                     | .62       |
| 4.1.11    | Modem Features  | .63       |
| 4.1.12    | Oscillators   | .64       |
| 4.1.12.1  | LFXO  | .64       |
| 4.1.12.2  | HFXO  | .65       |
| 4.1.12.3  | LFRCO   | .65       |
| 4.1.12.4  | HFRCO and AUXHFRCO  | .66       |
| 4.1.12.5  | ULFRCO  | .66       |
| 4.1.13    | Flash Memory Characteristics  | .67       |



|           |  |            |
|-----------|--|------------|
| 4.1.14    | GPIO   | .68        |
| 4.1.15    | VMON   | .69        |
| 4.1.16    | ADC  | .70        |
| 4.1.17    | IDAC   | .72        |
| 4.1.18    | Analog Comparator (ACMP)                         | .74        |
| 4.1.19    | I2C  | .76        |
| 4.1.20    | USART SPI  | .78        |
| 4.2       | Typical Performance Curves                       | .79        |
| 4.2.1     | Supply Current                                   | .80        |
| 4.2.2     | DC-DC Converter                                  | .82        |
| 4.2.3     | Internal Oscillators                             | .84        |
| 4.2.4     | 2.4 GHz Radio                                    | .90        |
| <b>5.</b> | <b>Typical Connection Diagrams</b>               | <b>92</b>  |
| 5.1       | Power  | .92        |
| 5.2       | RF Matching Networks                             | .94        |
| 5.3       | Other Connections                                | .95        |
| <b>6.</b> | <b>Pin Definitions</b>                           | <b>96</b>  |
| 6.1       | EFR32FG1 QFN48 Sub-GHz Definition                | .96        |
| 6.1.1     | EFR32FG1 QFN48 Sub-GHz GPIO Overview             | 108        |
| 6.2       | EFR32FG1 QFN48 2.4 GHz Definition                | 109        |
| 6.2.1     | EFR32FG1 QFN48 2.4 GHz GPIO Overview             | 121        |
| 6.3       | EFR32FG1 QFN48 2.4 GHz and Sub-GHz Definition    | 122        |
| 6.3.1     | EFR32FG1 QFN48 2.4 GHz and Sub-GHz GPIO Overview | 133        |
| 6.4       | EFR32FG1 QFN32 Sub-GHz Definition                | 134        |
| 6.4.1     | EFR32FG1 QFN32 Sub-GHz GPIO Overview             | 140        |
| 6.5       | EFR32FG1 QFN32 2.4 GHz Definition                | 141        |
| 6.5.1     | EFR32FG1 QFN32 2.4 GHz GPIO Overview             | 147        |
| 6.6       | Alternate Functionality Pinout                   | 148        |
| 6.7       | Analog Port (APORT)                              | 155        |
| <b>7.</b> | <b>QFN48 Package Specifications</b>              | <b>163</b> |
| 7.1       | QFN48 Package Dimensions                         | 163        |
| 7.2       | QFN48 PCB Land Pattern                           | 165        |
| 7.3       | QFN48 Package Marking                            | 167        |
| <b>8.</b> | <b>QFN32 Package Specifications</b>              | <b>168</b> |
| 8.1       | QFN32 Package Dimensions                         | 168        |
| 8.2       | QFN32 PCB Land Pattern                           | 170        |
| 8.3       | QFN32 Package Marking                            | 172        |
| <b>9.</b> | <b>Revision History</b>                          | <b>173</b> |
| 9.1       | Revision 0.97                                    | 173        |
| 9.2       | Revision 0.951                                   | 173        |

---

|                                    |            |
|------------------------------------|------------|
| 9.3 Revision 0.95 . . . . .        | 173        |
| 9.4 Revision 0.9 . . . . .         | 173        |
| 9.5 Revision 0.81 . . . . .        | 173        |
| 9.6 Revision 0.8 . . . . .         | 173        |
| <b>Table of Contents . . . . .</b> | <b>174</b> |



## Simplicity Studio

One-click access to MCU and wireless tools, documentation, software, source code libraries & more. Available for Windows, Mac and Linux!



**IoT Portfolio**  
[www.silabs.com/IoT](http://www.silabs.com/IoT)



**SW/HW**  
[www.silabs.com/simplicity](http://www.silabs.com/simplicity)



**Quality**  
[www.silabs.com/quality](http://www.silabs.com/quality)



**Support and Community**  
[community.silabs.com](http://community.silabs.com)

### Disclaimer

Silicon Laboratories intends to provide customers with the latest, accurate, and in-depth documentation of all peripherals and modules available for system and software implementers using or intending to use the Silicon Laboratories products. Characterization data, available modules and peripherals, memory sizes and memory addresses refer to each specific device, and "Typical" parameters provided can and do vary in different applications. Application examples described herein are for illustrative purposes only. Silicon Laboratories reserves the right to make changes without further notice and limitation to product information, specifications, and descriptions herein, and does not give warranties as to the accuracy or completeness of the included information. Silicon Laboratories shall have no liability for the consequences of use of the information supplied herein. This document does not imply or express copyright licenses granted hereunder to design or fabricate any integrated circuits. The products are not designed or authorized to be used within any Life Support System without the specific written consent of Silicon Laboratories. A "Life Support System" is any product or system intended to support or sustain life and/or health, which, if it fails, can be reasonably expected to result in significant personal injury or death. Silicon Laboratories products are not designed or authorized for military applications. Silicon Laboratories products shall under no circumstances be used in weapons of mass destruction including (but not limited to) nuclear, biological or chemical weapons, or missiles capable of delivering such weapons.

### Trademark Information

Silicon Laboratories Inc.®, Silicon Laboratories®, Silicon Labs®, SiLabs® and the Silicon Labs logo®, Bluegiga®, Bluegiga Logo®, Clockbuilder®, CMEMS®, DSPLL®, EFM®, EFM32®, EFR®, Ember®, Energy Micro, Energy Micro logo and combinations thereof, "the world's most energy friendly microcontrollers", Ember®, EZLink®, EZRadio®, EZRadioPRO®, Gecko®, ISOModem®, Precision32®, ProSLIC®, Simplicity Studio®, SIPHY®, Telegesis, the Telegesis Logo®, USBXpress® and others are trademarks or registered trademarks of Silicon Laboratories Inc. ARM, CORTEX, Cortex-M3 and THUMB are trademarks or registered trademarks of ARM Holdings. Keil is a registered trademark of ARM Limited. All other products or brand names mentioned herein are trademarks of their respective holders.



Silicon Laboratories Inc.  
 400 West Cesar Chavez  
 Austin, TX 78701  
 USA

<http://www.silabs.com>