

UG95 Hardware Design

UMTS/HSPA Module Series

Rev. UG95_Hardware_Design_V1.3

Date: 2015-03-25



Our aim is to provide customers with timely and comprehensive service. For any assistance, please contact our company headquarters:

Quectel Wireless Solutions Co., Ltd.

Office 501, Building 13, No.99, Tianzhou Road, Shanghai, China, 200233

Tel: +86 21 5108 6236

Mail: info@quectel.com

Or our local office, for more information, please visit:

<http://www.quectel.com/support/salesupport.aspx>

For technical support, to report documentation errors, please visit:

<http://www.quectel.com/support/techsupport.aspx>

Or Email: Support@quectel.com

GENERAL NOTES

QUECTEL OFFERS THIS INFORMATION AS A SERVICE TO ITS CUSTOMERS. THE INFORMATION PROVIDED IS BASED UPON CUSTOMERS' REQUIREMENTS. QUECTEL MAKES EVERY EFFORT TO ENSURE THE QUALITY OF THE INFORMATION IT MAKES AVAILABLE. QUECTEL DOES NOT MAKE ANY WARRANTY AS TO THE INFORMATION CONTAINED HEREIN, AND DOES NOT ACCEPT ANY LIABILITY FOR ANY INJURY, LOSS OR DAMAGE OF ANY KIND INCURRED BY USE OF OR RELIANCE UPON THE INFORMATION. THE INFORMATION SUPPLIED HEREIN IS SUBJECT TO CHANGE WITHOUT PRIOR NOTICE.

COPYRIGHT

THIS INFORMATION CONTAINED HERE IS PROPRIETARY TECHNICAL INFORMATION OF QUECTEL CO., LTD. TRANSMITTABLE, REPRODUCTION, DISSEMINATION AND EDITING OF THIS DOCUMENT AS WELL AS UTILIZATION OF THIS CONTENTS ARE FORBIDDEN WITHOUT PERMISSION. OFFENDERS WILL BE HELD LIABLE FOR PAYMENT OF DAMAGES. ALL RIGHTS ARE RESERVED IN THE EVENT OF A PATENT GRANT OR REGISTRATION OF A UTILITY MODEL OR DESIGN.

Copyright © Quectel Wireless Solutions Co., Ltd. 2015. All rights reserved.

About the Document

History

Revision	Date	Author	Description
1.0	2014-06-20	Yeoman CHEN	Initial
1.1	2014-08-21	Yeoman CHEN	<ol style="list-style-type: none"> Updated transmitting power information. Added reference design for power supply in Chapter 3.6.3. Updated timing of turning on module in Figure 9. Added definition for the backup capacitor value in Chapter 3.9. Added reference design of 5V level match circuit in Figure 18. Updated RS232 level match circuit in Figure 19. Updated frequency range in Table 23. Updated reference circuit of USB interface in Figure 24. Added diagram for USB upgrade test points. Updated RF output power in Table 28. Updated recommended footprint in Figure 36.
1.2	2014-11-18	Yeoman CHEN	<ol style="list-style-type: none"> Modified VBAT input low voltage to 3.3V. Modified preconditions of entering into the sleep mode in Chapter 3.5.1. Updated Chapter 3.7.2. Deleted Chapter 3.11.2. Updated antenna requirements in Table 21. Updated recommended footprint in Figure 35. Updated packaging information in Chapter 7.3.
1.3	2015-03-25	Yeoman CHEN/ Jackie WANG	<ol style="list-style-type: none"> Updated Figure 4 & 5. Updated Chapter 3.13. Opened PIN25 CLK_OUT. Added recommended stencil in Chapter 6.2.

Contents

About the Document	2
Contents	3
Table Index	5
Figure Index	6
1 Introduction	8
1.1. Safety Information.....	9
2 Product Concept	10
2.1. General Description.....	10
2.2. Key Features.....	11
2.3. Functional Diagram.....	13
2.4. Evaluation Board.....	14
3 Application Interface	15
3.1. General Description.....	15
3.2. Pin Assignment.....	16
3.3. Pin Description.....	17
3.4. Operating Modes.....	22
3.5. Power Saving.....	23
3.5.1. Sleep Mode.....	23
3.5.1.1. UART Application.....	23
3.5.1.2. USB Application with Suspend Function.....	24
3.5.1.3. USB Application without Suspend Function.....	25
3.5.2. Minimum Functionality Mode.....	26
3.6. Power Supply.....	26
3.6.1. Power Supply Pins.....	26
3.6.2. Decrease Voltage Drop.....	27
3.6.3. Reference Design for Power Supply.....	28
3.6.4. Monitor the Power Supply.....	29
3.7. Turn on and off Scenarios.....	29
3.7.1. Turn on Module.....	29
3.7.2. Turn off Module.....	31
3.7.2.1. Turn off Module Using AT Command.....	31
3.7.2.2. Emergency Shutdown.....	32
3.7.2.3. Automatic Shutdown.....	34
3.8. Reset the Module.....	34
3.9. RTC Interface.....	36
3.10. UART Interface.....	37
3.11. USIM Card Interface.....	39
3.12. USB Interface.....	42
3.13. PCM and I2C Interface.....	44
3.14. Network Status Indication.....	46

3.15.	Operating Status Indication	47
4	Antenna Interface.....	48
4.1.	GSM/UMTS Antenna Interface.....	48
4.1.1.	Pin Definition	48
4.1.2.	Operating Frequency	48
4.1.3.	Reference Design	49
4.2.	Antenna Installation	49
4.2.1.	Antenna Requirement	49
4.2.2.	Install the Antenna with RF Connector	50
5	Electrical, Reliability and Radio Characteristics	52
5.1.	Absolute Maximum Ratings.....	52
5.2.	Power Supply Ratings	52
5.3.	Operating Temperature.....	53
5.4.	Current Consumption	53
5.5.	RF Output Power	55
5.6.	RF Receiving Sensitivity.....	56
5.7.	Electrostatic Discharge.....	56
6	Mechanical Dimensions	57
6.1.	Mechanical Dimensions of the Module.....	57
6.2.	Footprint of Recommendation	59
6.3.	Top View of the Module	61
6.4.	Bottom View of the Module.....	61
7	Storage and Manufacturing	62
7.1.	Storage.....	62
7.2.	Manufacturing and Welding.....	62
7.3.	Packaging	64
8	Appendix A Reference.....	66
9	Appendix B GPRS Coding Scheme	70
10	Appendix C GPRS Multi-slot Class	71
11	Appendix D EDGE Modulation and Coding Scheme	72

Table Index

TABLE 1: UG95 SERIES FREQUENCY BANDS.....	10
TABLE 2: UG95 KEY FEATURES	11
TABLE 3: IO PARAMETERS DEFINITION.....	17
TABLE 4: PIN DESCRIPTION	17
TABLE 5: OVERVIEW OF OPERATING MODES.....	22
TABLE 6: VBAT AND GND PINS.....	26
TABLE 7: PWRKEY PIN DESCRIPTION	29
TABLE 8: PWRDWN_N PIN DESCRIPTION	32
TABLE 9: RESET_N PIN DESCRIPTION	34
TABLE 10: PIN DEFINITION OF THE MAIN UART INTERFACE.....	37
TABLE 11: LOGIC LEVELS OF DIGITAL I/O	37
TABLE 12: PIN DEFINITION OF THE USIM INTERFACE	40
TABLE 13: USB PIN DESCRIPTION	42
TABLE 14: PIN DEFINITION OF PCM AND I2C INTERFACE.....	44
TABLE 15: PIN DEFINITION OF NETWORK INDICATOR.....	46
TABLE 16: WORKING STATE OF THE NETWORK INDICATOR.....	46
TABLE 17: PIN DEFINITION OF STATUS	47
TABLE 18: PIN DEFINITION OF THE RF ANTENNA.....	48
TABLE 19: THE MODULE OPERATING FREQUENCIES.....	48
TABLE 20: ANTENNA CABLE REQUIREMENTS.....	49
TABLE 21: ANTENNA REQUIREMENTS.....	50
TABLE 22: ABSOLUTE MAXIMUM RATINGS	52
TABLE 23: THE MODULE POWER SUPPLY RATINGS	52
TABLE 24: OPERATING TEMPERATURE.....	53
TABLE 25: THE MODULE CURRENT CONSUMPTION	53
TABLE 26: CONDUCTED RF OUTPUT POWER	55
TABLE 27: CONDUCTED RF RECEIVING SENSITIVITY.....	56
TABLE 28: REEL PACKING	65
TABLE 29: RELATED DOCUMENTS	66
TABLE 30: TERMS AND ABBREVIATIONS	66
TABLE 31: DESCRIPTION OF DIFFERENT CODING SCHEMES	70
TABLE 32: GPRS MULTI-SLOT CLASSES	71
TABLE 33: EDGE MODULATION AND CODING SCHEME	72

Figure Index

FIGURE 1: FUNCTIONAL DIAGRAM	14
FIGURE 2: PIN ASSIGNMENT (TOP VIEW)	16
FIGURE 3: UART SLEEP APPLICATION	24
FIGURE 4: USB APPLICATION WITH SUSPEND FUNCTION.....	25
FIGURE 5: USB SLEEP APPLICATION WITHOUT SUSPEND FUNCTION.....	25
FIGURE 6: VOLTAGE DROP DURING TRANSMITTING BURST.....	27
FIGURE 7: STAR STRUCTURE OF THE POWER SUPPLY.....	28
FIGURE 8: REFERENCE CIRCUIT OF POWER SUPPLY	28
FIGURE 9: TURN ON THE MODULE USING DRIVING CIRCUIT	29
FIGURE 10: TURN ON THE MODULE USING KEYSTROKE	30
FIGURE 11: TIMING OF TURNING ON MODULE	30
FIGURE 12: TIMING OF TURNING OFF THROUGH AT COMMAND	31
FIGURE 13: TURN OFF THE MODULE USING DRIVING CIRCUIT	32
FIGURE 14: TURN OFF THE MODULE USING KEYSTROKE.....	33
FIGURE 15: TIMING OF EMERGENCY SHUTDOWN.....	33
FIGURE 16: REFERENCE CIRCUIT OF RESET_N BY USING DRIVING CIRCUIT	35
FIGURE 17: REFERENCE CIRCUIT OF RESET_N BY USING BUTTON	35
FIGURE 18: TIMING OF RESETTING MODULE	35
FIGURE 19: RTC SUPPLY FROM CAPACITOR	36
FIGURE 20: REFERENCE CIRCUIT OF LOGIC LEVEL TRANSLATOR.....	38
FIGURE 21: REFERENCE CIRCUIT WITH TRANSISTOR CIRCUIT	38
FIGURE 22: RS232 LEVEL MATCH CIRCUIT.....	39
FIGURE 23: REFERENCE CIRCUIT OF THE 8-PIN USIM CARD	40
FIGURE 24: REFERENCE CIRCUIT OF THE 6-PIN USIM CARD	41
FIGURE 25: REFERENCE CIRCUIT OF USB APPLICATION	42
FIGURE 26: TEST POINTS OF FIRMWARE UPGRADE	43
FIGURE 27: PCM MASTER MODE TIMING.....	45
FIGURE 28: REFERENCE CIRCUIT OF PCM APPLICATION WITH AUDIO CODEC	45
FIGURE 29: REFERENCE CIRCUIT OF THE NETLIGHT	47
FIGURE 30: REFERENCE CIRCUIT OF THE STATUS	47
FIGURE 31: REFERENCE CIRCUIT OF ANTENNA INTERFACE	49
FIGURE 32: DIMENSIONS OF THE UF.L-R-SMT CONNECTOR (UNIT: MM)	50
FIGURE 33: MECHANICALS OF UF.L-LP CONNECTORS (UNIT: MM).....	51
FIGURE 34: SPACE FACTOR OF MATED CONNECTOR (UNIT: MM)	51
FIGURE 35: UG95 TOP AND SIDE DIMENSIONS.....	57
FIGURE 36: UG95 BOTTOM DIMENSION (TOP VIEW).....	58
FIGURE 37: RECOMMENDED FOOTPRINT (TOP VIEW)	59
FIGURE 38: RECOMMENDED STENCIL OF UG95 (TOP VIEW)	60
FIGURE 39: TOP VIEW OF THE MODULE	61
FIGURE 40: BOTTOM VIEW OF THE MODULE.....	61
FIGURE 41: REFLOW SOLDERING PROFILE.....	63

FIGURE 42: TAPE AND REEL SPECIFICATION..... 64
FIGURE 43: DIMENSIONS OF REEL..... 65

Quectel
Confidential

1 Introduction

This document defines the UG95 module and describes its hardware interface which are connected with your application and the air interface.

This document can help you quickly understand module interface specifications, electrical and mechanical details. Associated with application notes and user guide, you can use UG95 module to design and set up mobile applications easily.

Quectel
Confidential

1.1. Safety Information

The following safety precautions must be observed during all phases of the operation, such as usage, service or repair of any cellular terminal or mobile incorporating UG95 module. Manufacturers of the cellular terminal should send the following safety information to users and operating personnel and to incorporate these guidelines into all manuals supplied with the product. If not so, Quectel does not take on any liability for customer failure to comply with these precautions.



Full attention must be given to driving at all times in order to reduce the risk of an accident. Using a mobile while driving (even with a handsfree kit) cause distraction and can lead to an accident. You must comply with laws and regulations restricting the use of wireless devices while driving.



Switch off the cellular terminal or mobile before boarding an aircraft. Make sure it switched off. The operation of wireless appliances in an aircraft is forbidden to prevent interference with communication systems. Consult the airline staff about the use of wireless devices on boarding the aircraft, if your device offers a Airplane Mode which must be enabled prior to boarding an aircraft.



Switch off your wireless device when in hospitals or clinics or other health care facilities. These requests are desinged to prevent possible interference with sentitive medical equipment.



Cellular terminals or mobiles operate over radio frequency signal and cellular network and cannot be guaranteed to connect in all conditions, for example no mobile fee or an invalid SIM card. While you are in this condition and need emergent help, please remember using emergency call. In order to make or receive call, the cellular terminal or mobile must be switched on and in a service area with adequate cellular signal strength.



Your cellular terminal or mobile contains a transmitter and receiver. When it is ON , it receives and transmits radio frequency energy. RF interference can occur if it is used close to TV set, radio, computer or other electric equipment.



In locations with potentially explosive atmospheres, obey all posted signs to turn off wireless devices such as your phone or other cellular terminals. Areas with potentially expositive atmospheres including fuelling areas, below decks on boats, fuel or chemical transfer or storage facilities, areas where the air contains chemicals or particles such as grain, dust or metal powders.

2 Product Concept

2.1. General Description

UG95 series are embedded 3G wireless communication modules, support GSM/GPRS/EDGE and UMTS/HSDPA/HSUPA networks. They can also provide voice functionality¹⁾ for your specific application. UG95 offers a maximum data rate of 7.2Mbps on downlink and 5.76Mbps on uplink in HSPA mode. GPRS supports the coding schemes CS-1, CS-2, CS-3 and CS-4. EDGE supports CS1-4 and MCS1-9 coding schemes. UG95 contains two variants UG95-A and UG95-E. You can choose the dedicated type based on the wireless network configuration. The following table shows the entire radio band configuration of UG95 series.

Table 1: UG95 Series Frequency Bands

Module	GSM 850	EGSM 900	DCS 1800	PCS 1900	UMTS 850	UMTS 900	UMTS 1900	UMTS 2100
UG95-A					✓		✓	
UG95-E		✓	✓			✓		✓

NOTE

¹⁾ UG95 series (UG95-A/UG95-E) includes Data-only and Telematics versions. Data-only version does not support voice function, Telematics version supports it.

More details about GPRS/EDGE multi-slot configuration and coding schemes, please refer to **Appendix B, C and D**.

With a tiny profile of 23.6mm × 19.9mm × 2.2mm, UG95 can meet almost all requirements for M2M application such as automotive, metering, tracking system, security solutions, routers, wireless POS, etc..

UG95 is an SMD type module, which can be embedded in application through its 102 LGA pads.

UG95 is integrated with internet service protocols like TCP/UDP and PPP. Extended AT commands have been developed for you to use these internet service protocols easily.

2.2. Key Features

The following table describes the detailed features of UG95 module.

Table 2: UG95 Key Features

Feature	Details
Power Supply	Supply voltage: 3.3V ~ 4.3V Typical supply voltage: 3.8V
Frequency Bands	UG95-A: UMTS Dual-band: 850/1900MHz UG95-E: GSM Dual-band: 900/1800MHz UMTS Dual-band: 900/2100MHz
Transmission Data	HSDPA category 8: Max 7.2Mbps HSUPA category 6: Max 5.76Mbps UMTS: Max 384kbps (DL)/Max 384kbps (UL) EDGE: Max 236.8kbps (DL only) GPRS: Max 85.6kbps (DL)/Max 85.6kbps (UL) CSD: 14.4kbps
Transmitting Power	Class 4 (33dBm±2dB) for EGSM900 Class 1 (30dBm±2dB) for DCS1800 Class 3 (24dBm+1.7/-3.7dB) for UMTS 850/900/1900/2100
HSPA/UMTS Features	Compliant with 3GPP Release 7 WCDMA data rate is corresponded with 3GPP R4 384kbps on downlink and 384kbps on uplink Support both QPSK and 16-QAM modulations
GSM/GPRS/EDGE Data Features	GPRS: Support GPRS multi-slot class 12 Coding scheme: CS-1, CS-2, CS-3 and CS-4 Maximum of four Rx time slots per frame EDGE: Support EDGE multi-slot class 12 Support GMSK and 8-PSK for different MCS (Modulation and Coding scheme) Coding scheme: MCS 1-9 Downlink only CSD: CSD transmission rates: 14.4kbps non-transparent Support Unstructured Supplementary Services Data (USSD)
Internet Protocol Features	Support TCP/UDP/PPP protocols

	Support the protocols PAP (Password Authentication Protocol) and CHAP (Challenge Handshake Authentication Protocol) usually used for PPP connections
SMS	Text and PDU mode Point to point MO and MT SMS cell broadcast SMS storage: SIM card by default
USIM Interface	Support USIM card: 1.8V, 3.0V Support USIM and SIM
PCM Interface	Used for audio function with external codec Supports 8, 16, 32 bit mode with short frame synchronization Support master mode
UART Interface	Support one UART interface. <ul style="list-style-type: none"> ● 7-wire on UART interface, without DSR ● Support RTS and CTS hardware flow control ● Baud rate 300 to 921600bps ● Default autobauding 4800 to 115200bps ● Used for AT command, data transmission or firmware upgrade ● Multiplexing function
USB Interface	Compliant with USB 1.1/2.0 specification (slave only), the data transfer rate can reach up to 480Mbps Used for AT command communication, data transmission, software debug and firmware upgrade USB Driver: Support Windows XP, Windows Vista, Windows 7, Windows 8, Windows CE5.0/6.0*, Linux, Android
AT Commands	Compliant with 3GPP TS 27.007, 27.005 and Quectel enhanced AT commands
Real Time Clock	Implemented
Network Indication	One pin NETLIGHT to indicate network connectivity status
Antenna Interface	GSM/UMTS antenna, 50Ω
Physical Characteristics	Size: 19.9±0.15 × 23.6±0.15 × 2.2±0.2mm Interface: LGA Weight: 2.5g
Temperature Range	Normal operation: -35°C ~ +80°C Restricted operation: -40°C ~ -35°C and +80°C ~ +85°C ¹⁾ Storage temperature: -45°C ~ +90°C
Firmware Upgrade	USB interface or UART interface
RoHS	All hardware components are fully compliant with EU RoHS directive

NOTES

1. ¹⁾ means when the module works within this temperature range, RF performance might degrade. For example, the frequency error or the phase error would increase.
2. * means this feature is under development.

2.3. Functional Diagram

The following figure shows a block diagram of UG95 and illustrates the major functional parts.

- RF transceiver
- Baseband
- DDR+NAND flash
- Radio frequency
- Peripheral interfaces
 - UART interface
 - USIM card interface
 - USB interface
 - PCM interface
 - I2C interface
 - Status indication
 - Control interface

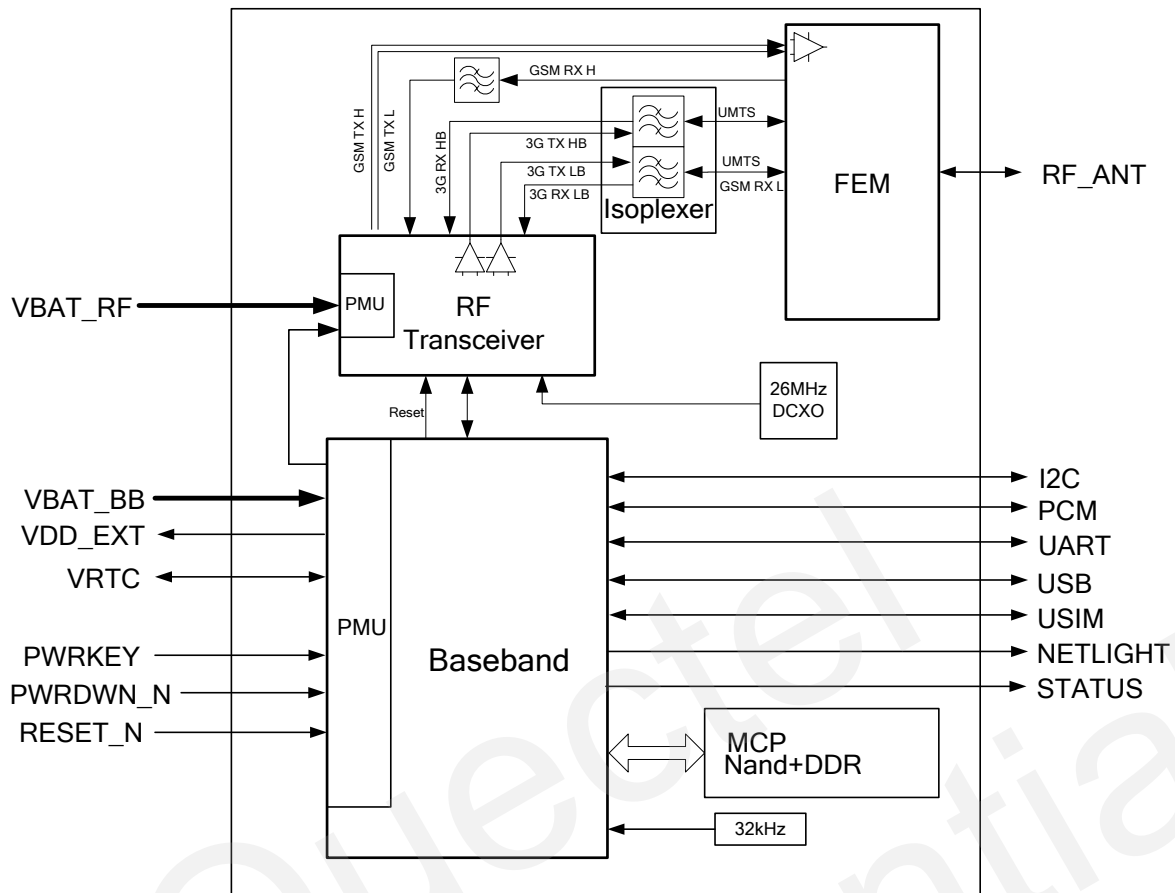

Figure 1: Functional Diagram

2.4. Evaluation Board

In order to help you to develop applications with UG95, Quectel supplies an evaluation board (UMTS<E-EVB), RS-232 to USB cable, USB data cable, power adapter, earphone, antenna and other peripherals to control or test the module. For details, please refer to **document [2]**.

3 Application Interface

3.1. General Description

UG95 is equipped with a 62-pin 1.1mm pitch SMT pads plus 40-pin ground pads and reserved pads that connect to customer's cellular application platform. Sub-interfaces included in these pads are described in detail in the following chapters:

- Power supply
- RTC interface
- UART interface
- USIM interface
- USB interface
- PCM interface
- Status indication

Quectel
Confidential

3.3. Pin Description

The following tables show the UG95's pin definition.

Table 3: IO Parameters Definition

Type	Description
IO	Bidirectional input/output
DI	Digital input
DO	Digital output
PI	Power input
PO	Power output
AI	Analog input
AO	Analog output
OD	Open drain

Table 4: Pin Description

Power Supply					
Pin Name	Pin No.	I/O	Description	DC Characteristics	Comment
VBAT_BB	32, 33	PI	Power supply for module baseband part.	Vmax=4.3V Vmin=3.3V Vnorm=3.8V	It must be able to provide sufficient current in a transmitting burst which typically rises to 2.0A.
VBAT_RF	52, 53	PI	Power supply for module RF part.	Vmax=4.3V Vmin=3.3V Vnorm=3.8V	
VRTC	51	PI/ PO	Power supply for internal RTC circuit.	Vnorm=1.8V when VBAT ≥ 3.3V. V _I =1V~1.9V at I _{IN} max=2uA when VBAT is not applied.	If unused, keep this pin open.
VDD_EXT	29	PO	Provide 1.8V for external circuit.	Vnorm=1.8V I _O max=20mA	Power supply for external GPIO's pull up circuits.

If unused, keep this pin open.

GND	3, 31, 48, 50, 54, 55, 58, 59, 61, 62, 67~74, 79~82, 89~91, 100~102	Ground
-----	---	--------

Turn On/Off

Pin Name	Pin No.	I/O	Description	DC Characteristics	Comment
PWRKEY	15	DI	Turn on the module	$R_{PU} \approx 200k\Omega$ $V_{IHmax} = 2.1V$ $V_{IHmin} = 1.3V$ $V_{ILmax} = 0.5V$	Pull-up to VRTC internally. Active low.
PWRDWN_N	16	DI	Turn off the module	$R_{PU} \approx 4.7k\Omega$ $V_{IHmax} = 2.1V$ $V_{IHmin} = 1.3V$ $V_{ILmax} = 0.5V$	Pull-up to VRTC internally. Active low. If unused, keep this pin open.
RESET_N	17	DI	Reset the module	$R_{PU} \approx 200k\Omega$ $V_{IHmax} = 2.1V$ $V_{IHmin} = 1.3V$ $V_{ILmax} = 0.5V$	Pull-up to VRTC internally. Active low. If unused, keep this pin open.

Status Indication

Pin Name	Pin No.	I/O	Description	DC Characteristics	Comment
STATUS	20	DO	Indicate the module operating status.	$V_{OHmin} = 1.3V$ $V_{OLmax} = 0.5V$	1.8V power domain. If unused, keep this pin open.
NETLIGHT	21	DO	Indicate the module network status.	$V_{OHmin} = 1.3V$ $V_{OLmax} = 0.5V$	1.8V power domain. If unused, keep this pin open.

USB Interface

Pin Name	Pin No.	I/O	Description	DC Characteristics	Comment
USB_VBUS	8	PI	USB insert detection.	$V_{max} = 5.25V$ $V_{min} = 2.5V$ $V_{norm} = 5.0V$	USB insert detection.

USB_DP	9	IO	USB differential data bus.	Compliant with USB 2.0 standard specification.	Require differential impedance of 90Ω.
USB_DM	10	IO	USB differential data bus.	Compliant with USB 2.0 standard specification.	Require differential impedance of 90Ω.

USIM Interface

Pin Name	Pin No.	I/O	Description	DC Characteristics	Comment
USIM_GND	47		Specified ground for USIM card.		
USIM_VDD	43	PO	Power supply for USIM card.	For 1.8V USIM: Vmax=1.85V Vmin=1.75V For 3.0V USIM: Vmax=2.9V Vmin=2.8V	Either 1.8V or 3.0V is supported by the module automatically.
USIM_DATA	45	IO	Data signal of USIM card.	For 1.8V USIM: V _{IL} max=0.35V V _{IH} min=1.25V V _{OL} max=0.25V V _{OH} min=1.25V For 3.0V USIM: V _{IL} max=0.5V V _{IH} min=2.05V V _{OL} max=0.25V V _{OH} min=2.05V	Pull-up to USIM_VDD with 4.7K resistor internally.
USIM_CLK	46	DO	Clock signal of USIM card.	For 1.8V USIM: V _{OL} max=0.25V V _{OH} min=1.25V For 3.0V USIM: V _{OL} max=0.25V V _{OH} min=2.05V	
USIM_RST	44	DO	Reset signal of USIM card.	For 1.8V USIM: V _{OL} max=0.25V V _{OH} min=1.25V For 3.0V USIM: V _{OL} max=0.3V V _{OH} min=2.05V	

USIM_PRES ENCE	42	DI	USIM card input detection.	$V_{ILmax}=0.35V$ $V_{IHmin}=1.3V$ $V_{IHmax}=1.85V$	1.8V power domain. External pull-up resistor is required.
-------------------	----	----	-------------------------------	--	---

Main UART Interface

Pin Name	Pin No.	I/O	Description	DC Characteristics	Comment
RI	39	DO	Ring indicator	$V_{OLmax}=0.25V$ $V_{OHmin}=1.55V$	1.8V power domain. If unused, keep this pin open.
DCD	38	DO	Data carrier detection	$V_{OLmax}=0.25V$ $V_{OHmin}=1.55V$	1.8V power domain. If unused, keep this pin open.
CTS	36	DO	Clear to send	$V_{OLmax}=0.25V$ $V_{OHmin}=1.55V$	1.8V power domain. If unused, keep this pin open.
RTS	37	DI	Request to send	$V_{ILmax}=0.35V$ $V_{IHmin}=1.3V$ $V_{IHmax}=1.85V$	1.8V power domain. If unused, keep this pin open.
DTR	30	DI	Data terminal ready	$V_{ILmax}=0.35V$ $V_{IHmin}=1.3V$ $V_{IHmax}=1.85V$	1.8V power domain. If unused, keep this pin open.
TXD	35	DO	Transmit data	$V_{OLmax}=0.25V$ $V_{OHmin}=1.55V$	1.8V power domain. If unused, keep this pin open.
RXD	34	DI	Receive data	$V_{ILmax}=0.35V$ $V_{IHmin}=1.3V$ $V_{IHmax}=1.85V$	1.8V power domain. If unused, keep this pin open.

RF Interface

Pin Name	Pin No.	I/O	Description	DC Characteristics	Comment
RF_ANT	60	IO	RF antenna	50Ω impedance	

PCM Interface

Pin Name	Pin No.	I/O	Description	DC Characteristics	Comment
PCM_IN	6	DI	PCM data input	$V_{ILmin}=-0.3V$ $V_{ILmax}=0.35V$ $V_{IHmin}=1.3V$ $V_{IHmax}=1.85V$	1.8V power domain. If unused, keep this pin open.
PCM_OUT	7	DO	PCM data output	$V_{OLmax}=0.25V$ $V_{OHmin}=1.55V$	1.8V power domain. If unused, keep this pin open.

PCM_SYNC	5	DO	PCM data frame sync signal	$V_{OLmax}=0.25V$ $V_{OHmin}=1.55V$	1.8V power domain. In master mode, it is an output signal. If unused, keep this pin open.
PCM_CLK	4	DO	PCM data bit clock	$V_{OLmax}=0.25V$ $V_{OHmin}=1.55V$	1.8V power domain. In master mode, it's an output signal. If unused, keep this pin open.

I2C Interface

Pin Name	Pin No.	I/O	Description	DC Characteristics	Comment
I2C_SCL	40	OD	I2C serial clock		1.8V power domain. External pull-up resistor is required. If unused, keep this pin open.
I2C_SDA	41	OD	I2C serial data		1.8V power domain. External pull-up resistor is required. If unused, keep this pin open.

Other Pins

Pin Name	Pin No.	I/O	Description	DC Characteristics	Comment
AP_READY	19	DI	Application processor sleep state detection.	$V_{ILmin}=-0.3V$ $V_{ILmax}=0.35V$ $V_{IHmin}=1.3V$ $V_{IHmax}=1.85V$	1.8V power domain. If unused, keep this pin open.
CLK_OUT	25	DO	Clock output		Provide a digital clock output for an external audio codec. If unused, keep this pin open.

RESERVED Pins

Pin Name	Pin No.	I/O	Description	DC Characteristics	Comment
RESERV ED	1, 2, 11~14, 18, 22~24,		Reserved		Keep these pins unconnected.

26~28,
49, 56, 57,
63~66,
75~78,
83~88,
92~99.

NOTE

The function of AP_READY is under development.

3.4. Operating Modes

The table below briefly summarizes the various operating modes referred in the following chapters.

Table 5: Overview of Operating Modes

Mode	Details	
Normal Operation	GSM Idle	The module has registered to the GSM network and is ready to send and receive data.
	GSM Talk/Data	GSM connection is ongoing. In this mode, the power consumption is decided by the configuration of power control level (PCL), dynamic DTX control and the working RF band.
	GPRS Idle	The module is ready for GPRS data transfer, but no data transfer is going on. In this case, power consumption depends on network setting and GPRS configuration.
	GPRS Data	There is GPRS data in transfer (PPP, TCP or UDP). In this mode, power consumption is decided by the PCL, working RF band and GPRS multi-slot configuration.
	EDGE Idle	The module is ready for data receive in EDGE mode, but no data is currently received. In this case, power consumption depends on network settings and EDGE configuration.
	EDGE Data	There is EDGE data in receive (PPP, TCP or UDP).
	UMTS Idle	The module has registered to the UMTS network and the module is ready to send and receive data.
	UMTS Talk/Data	UMTS connection is ongoing. In this mode, the power consumption is decided by network setting (e.g. TPC pattern) and data transfer rate.

	HSPA Idle	The module has registered to the HSPA network and the module is ready to send and receive data.
	HSPA Data	HSPA data transfer is ongoing. In this mode, the power consumption is decided by network setting (e.g. TPC pattern) and data transfer rate.
Minimum Functionality Mode	AT+CFUN command can set the module entering into a minimum functionality mode without removing the power supply. In this case, both RF function and USIM card will be invalid.	
Sleep Mode	In this mode, the current consumption of the module will be reduced to the minimal level. During this mode, the module can still receive paging message, SMS and voice call from the network normally.	
Power Down Mode	In this mode, the power management unit shuts down the power supply for the baseband part and RF part. Only the power supply for RTC remains. Software is not active. The serial interface is not accessible. Operating voltage (connected to VBAT_RF and VBAT_BB) remains applied.	

3.5. Power Saving

3.5.1. Sleep Mode

UG95 is able to reduce its current consumption to a minimum value during the sleep mode. The following section describes power saving procedure of UG95.

3.5.1.1. UART Application

If application processor communicates with module via UART interface, the following preconditions can let the module enter into the sleep mode.

- Execute AT command **AT+QCFG="uart/power",1,2** to close internal UART port.
- Execute AT command **AT+QCFG="uart/power",0,0** to set UART into auto on/off mode.
- Execute AT command **AT+QSCLK=1** to enable the sleep mode.
- Drive DTR to high level.

The following figure shows the connection between the module and application processor.

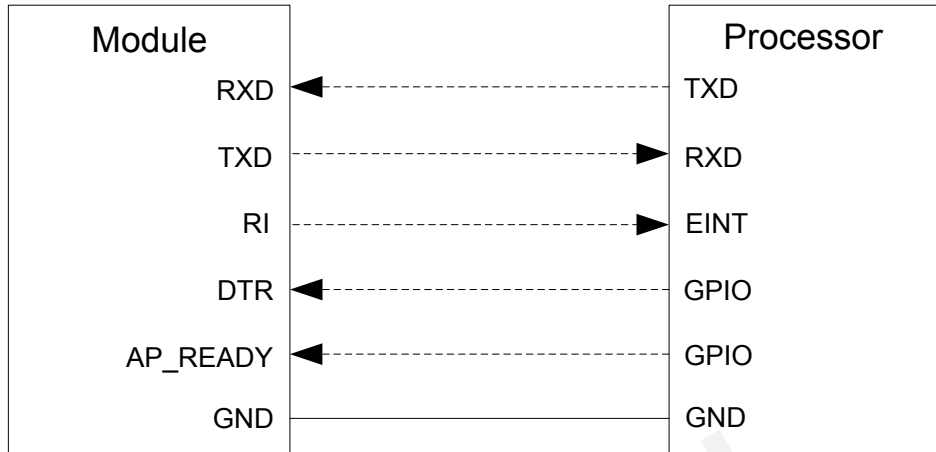

Figure 3: UART Sleep Application

The RI of module is used to wake up the processor, and AP_READY will detect the sleep state of processor (can be configured to high level or low level detection). You should pay attention to the level match shown in dotted line between module and processor. Drive DTR pin to low level to wake up the module.

In sleep mode for UART application, the UART port is not accessible.

3.5.1.2. USB Application with Suspend Function

If application processor communicates with module via USB interface, and processor supports USB suspend/resume function, the following preconditions can let the module enter into the sleep mode.

- Execute AT command **AT+QCFG="uart/power",1,2** to close internal UART port.
- Execute AT command **AT+QCFG="uart/power",0,0** to set UART into auto on/off mode.
- Execute AT command **AT+QSCLK=1** to enable the sleep mode.
- The processor's USB bus which is connected with the module USB interface enters into suspended state.

The following figure shows the connection between the module and processor.

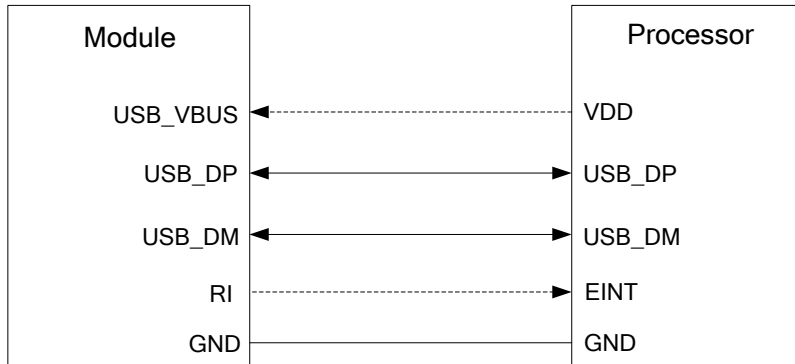

Figure 4: USB Application with Suspend Function

When the processor's USB bus returns to resume state, the module will be woken up.

3.5.1.3. USB Application without Suspend Function

If application processor communicates with module via USB interface, and processor does not support USB suspend/resume function. So processor should disconnect USB_VBUS with additional control circuit to let the module enter into sleep mode.

- Execute AT command **AT+QCFG="uart/power",1,2** to close internal UART port.
- Execute AT command **AT+QCFG="uart/power",0,0** to set UART into auto on/off mode.
- Execute AT command **AT+QSCLK=1** to enable the sleep mode.
- Disconnect USB_VBUS.

Supply power to USB_VBUS will wake up the module.

The following figure shows the connection between the module and application processor.

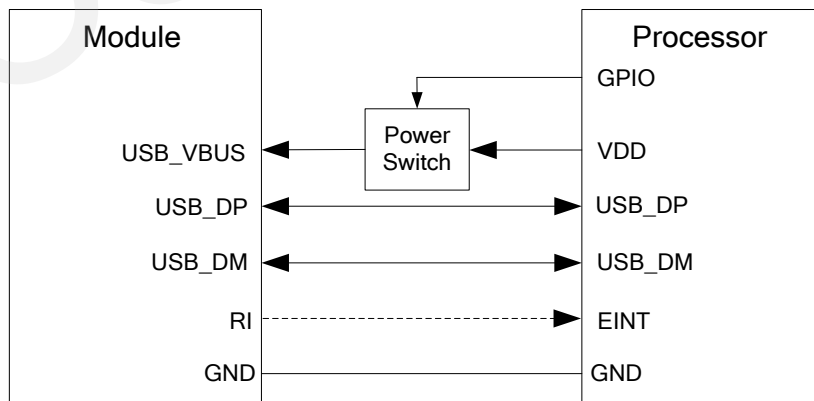

Figure 5: USB Sleep Application without Suspend Function

NOTES

1. In sleep mode, the module can still receive paging message, SMS, voice call and TCP/UDP data from the network normally.
2. The function of AP_READY is under development.

3.5.2. Minimum Functionality Mode

Minimum functionality mode reduces the functionality of the module to minimum level, thus minimizes the current consumption at the same time. This mode can be set as below:

Command **AT+CFUN** provides the choice of the functionality levels: <fun>=0, 1, 4.

- **AT+CFUN=0**: Minimum functionality, RF part and USIM card will be closed.
- **AT+CFUN=1**: Full functionality (by default).
- **AT+CFUN=4**: Disable RF function (airplane mode). All AT commands related to RF function are not accessible.

For detailed information about command **AT+CFUN**, please refer to **document [1]**.

3.6. Power Supply

3.6.1. Power Supply Pins

UG95 provides four VBAT pins dedicated to connect with the external power supply. There are two separate voltage domains for VBAT.

- VBAT_RF with two pads for module RF.
- VBAT_BB with two pads for module baseband.

The following table shows the VBAT pins and ground pins.

Table 6: VBAT and GND Pins

Pin Name	Pin No.	Description	Min.	Typ.	Max.	Unit
VBAT_RF	52, 53	Power supply for module RF part.	3.3	3.8	4.3	V
VBAT_BB	32, 33	Power supply for module baseband part.	3.3	3.8	4.3	V

	3, 31, 48, 50					
	54, 55, 58,					
	59, 61, 62,					
GND	67~74,	Ground	-	-	-	-
	79~82,					
	89~91,					
	100~102					

3.6.2. Decrease Voltage Drop

The power supply range of the module is 3.3V~ 4.3V. Make sure the input voltage will never drop below 3.3V. If the voltage drops below 3.3V, the module will turn off automatically. The following figure shows the voltage drop during transmitting burst in 2G network, the voltage drop will be less in 3G network.

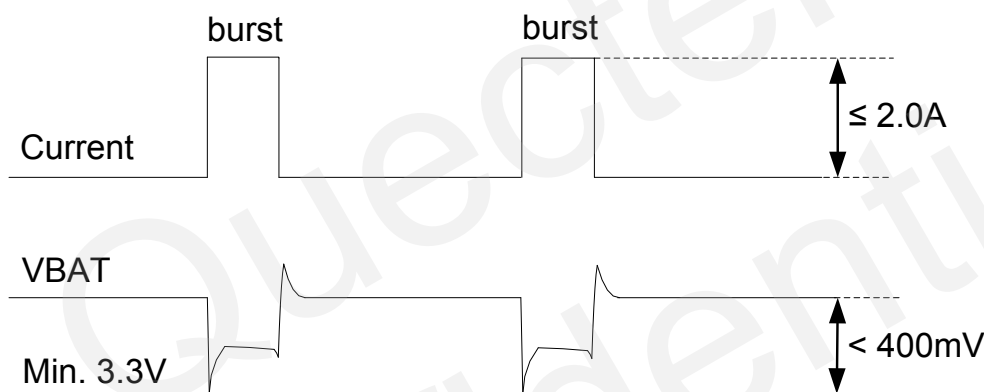

Figure 6: Voltage Drop during Transmitting Burst

To decrease voltage drop, a bypass capacitor of about 100μF with low ESR should be used. Multi-layer ceramic chip (MLCC) capacitor can provide the best combination of low ESR. The main power supply from an external application has to be a single voltage source and splits into two sub paths with star structure. The width of VBAT_BB trace should be no less than 1mm, and the width of VBAT_RF trace should be no less than 2mm, and the principle of the VBAT trace is the longer, the wider.

Three ceramic capacitors (100nF, 33pF, 10pF) are recommended to be applied to the VBAT pins. The capacitors should be placed close to the UG95's VBAT pins. In addition, in order to get a stable power source, it is suggested that you should use a zener diode of which reverse zener voltage is 5.1V and dissipation power is more than 0.5W. The following figure shows star structure of the power supply.

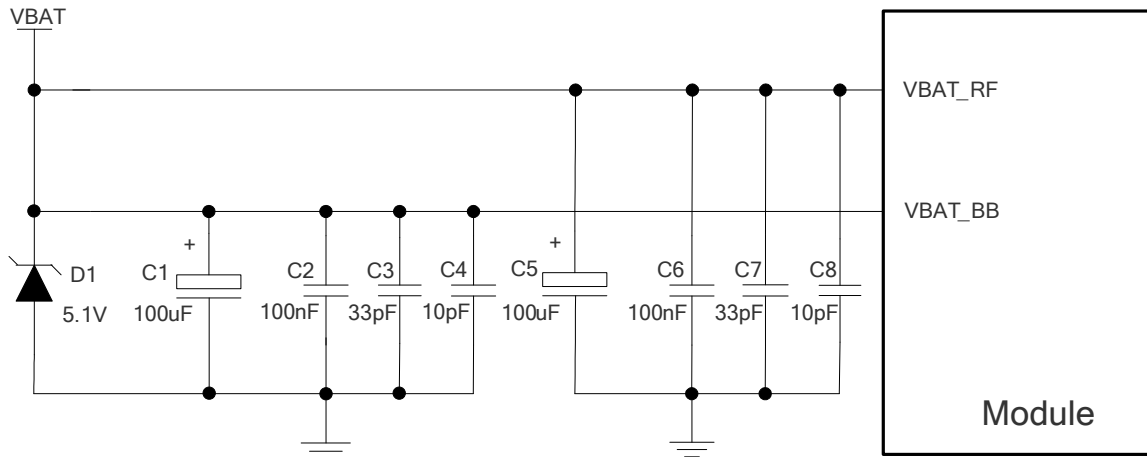

Figure 7: Star Structure of the Power Supply

3.6.3. Reference Design for Power Supply

The power design for the module is very important, since the performance of power supply for the module largely depends on the power source. The power supply is capable of providing the sufficient current up to 2A at least. If the voltage drop between the input and output is not too high, it is suggested that a LDO should be used to supply power for module. If there is a big voltage difference between the input source and the desired output (VBAT), a buck converter is preferred to be used as a power supply.

The following figure shows a reference design for +5V input power source. The designed output for the power supply is about 3.8V and the maximum load current is 3A.

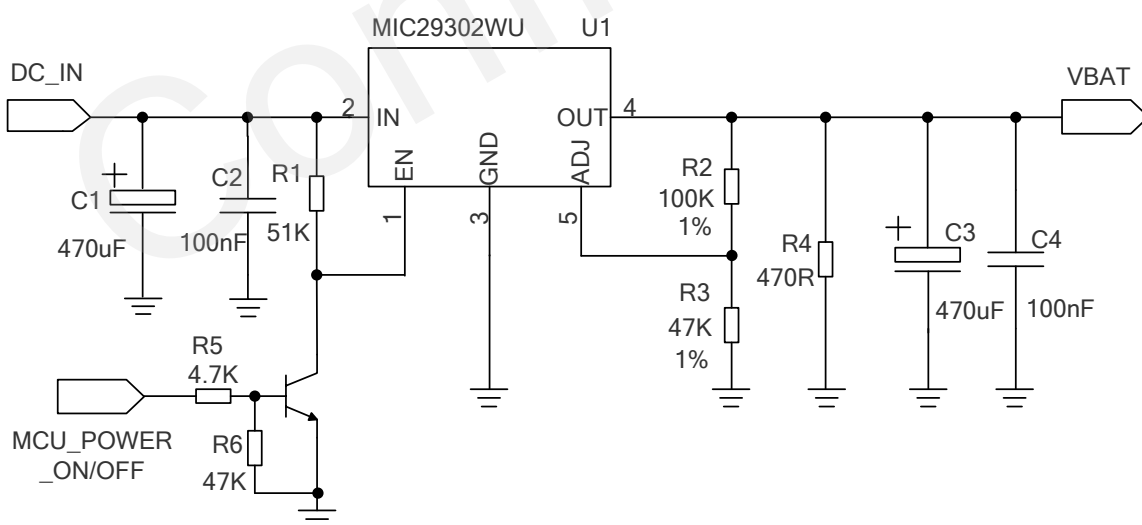

Figure 8: Reference Circuit of Power Supply

NOTE

It is suggested that you should switch off power supply for module in abnormal state, and then switch on power to restart module.

3.6.4. Monitor the Power Supply

The command **AT+CBC** can be used to monitor the VBAT_BB voltage value displayed in millivolt. For more details, please refer to **document [1]**.

3.7. Turn on and off Scenarios

3.7.1. Turn on Module

Turn on the module using the PWRKEY. The following table shows the pin definition of PWRKEY.

Table 7: PWRKEY Pin Description

Pin Name	Pin No.	Description	DC Characteristics	Comment
PWRKEY	15	Turn on the module	V _{IH} max=2.1V V _{IH} min=1.3V V _{IL} max=0.5V	Pull-up to VRTC internally with 200kΩ resistor.

When UG95 is in power down mode, it can be turned on to normal mode by driving the PWRKEY pin to a low level at least 100ms. It is recommended to use an open drain/collector driver to control the PWRKEY. The STATUS pin output a high level after UG95 is turned on. A simple reference circuit is illustrated in the following figure.

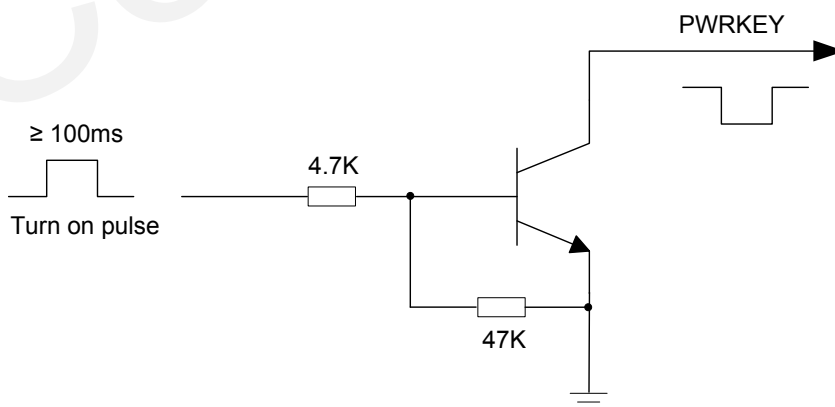

Figure 9: Turn on the Module Using Driving Circuit

The other way to control the PWRKEY is using a button directly. A TVS component is indispensable to be placed nearby the button for ESD protection. When pressing the key, electrostatic strike may generate from finger. A reference circuit is shown in the following figure.

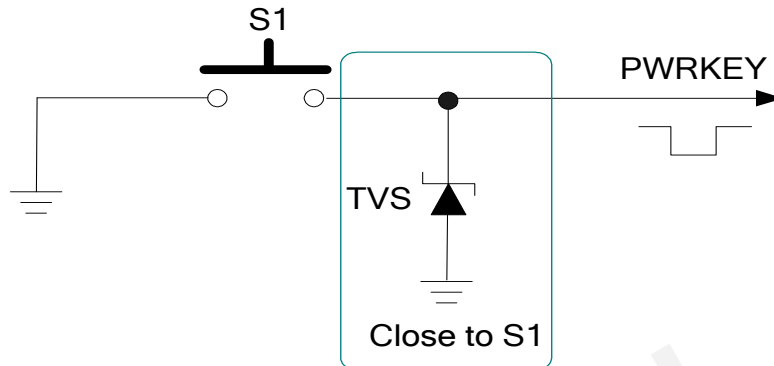

Figure 10: Turn on the Module Using Keystroke

The turn on scenarios is illustrated as the following figure.

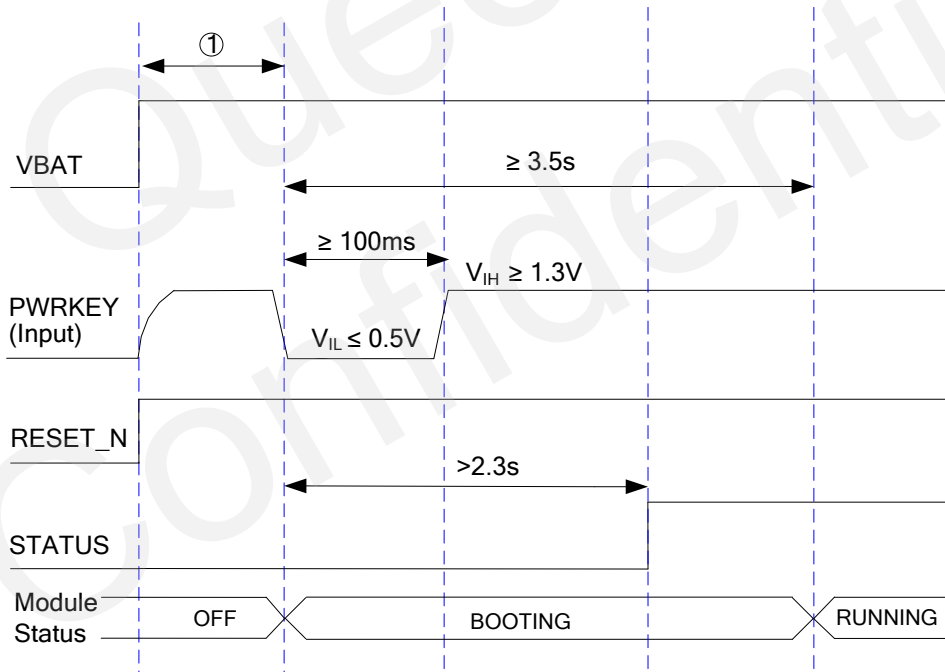

Figure 11: Timing of Turning on Module

NOTE

① Make sure that VBAT is stable before pulling down PWRKEY pin, the recommended delay time is at least 30ms. It is not suggested that PWRKEY pin is always pulled down.

3.7.2. Turn off Module

The following procedures can be used to turn off the module:

- Normal power down procedure: Turn off the module using command **AT+QPOWD**.
- Emergency power down procedure: Turn off the module using the PWRDWN_N pin.
- Automatic shutdown: Turn off the module automatically if under-voltage or over-voltage is detected.

3.7.2.1. Turn off Module Using AT Command

There are several different ways to turn off the module. It is recommended to turn off the module from AT command **AT+QPOWD**. It is a safe way to turn off the module. This command will let the module log off from the network and allow the firmware to save important data before completely disconnecting the power supply.

The power-down scenario is illustrated as the following figure.

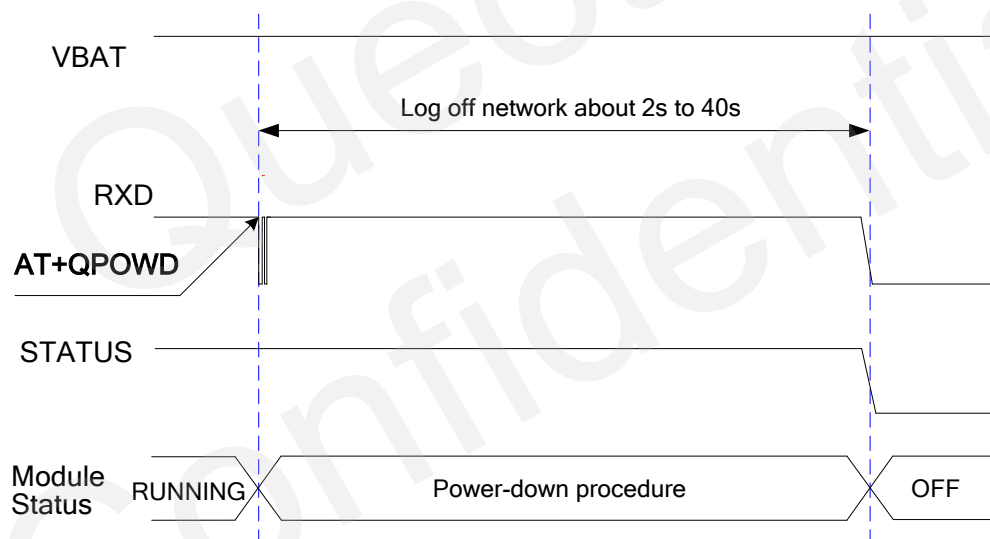

Figure 12: Timing of Turning off through AT Command

NOTE

The time of detaching network is related to local network signal.

During power-down procedure, module will log off network and save important data. After logging off, module sends out "OK", and then sends out "POWERED DOWN" and shuts down the internal power supply. The power on VBAT pins is not allowed to turn off before the URC "POWERED DOWN" is output

to avoid data loss. If logging off is not done within 40s, module will shut down internal power supply forcibly.

After that moment, the module enters the power down mode, no other AT commands can be executed, only the RTC is still active. Please refer to **document [1]** for details about the AT command of **AT+QPOWD**.

3.7.2.2. Emergency Shutdown

The module can be shut down by the pin PWRDWN_N. It should only be used under emergent situation.

The following table shows the pin definition of PWRDWN_N.

Table 8: PWRDWN_N Pin Description

Pin Name	Pin No.	Description	DC Characteristics	Comment
PWRDWN_N	16	Turn off the module	V _{IH} max=2.1V V _{IH} min=1.3V V _{IL} max=0.5V	Pull-up to VRTC internally with 4.7kΩ resistor.

Driving the PWRDWN_N to a low level voltage at least 100ms, the module will execute power-down procedure after PWRDWN_N is released. It is recommended to use an open drain/collector driver to control the PWRDWN_N. The level of STATUS pin is low after UG95 is turned off. A simple reference circuit is illustrated in the following figure.

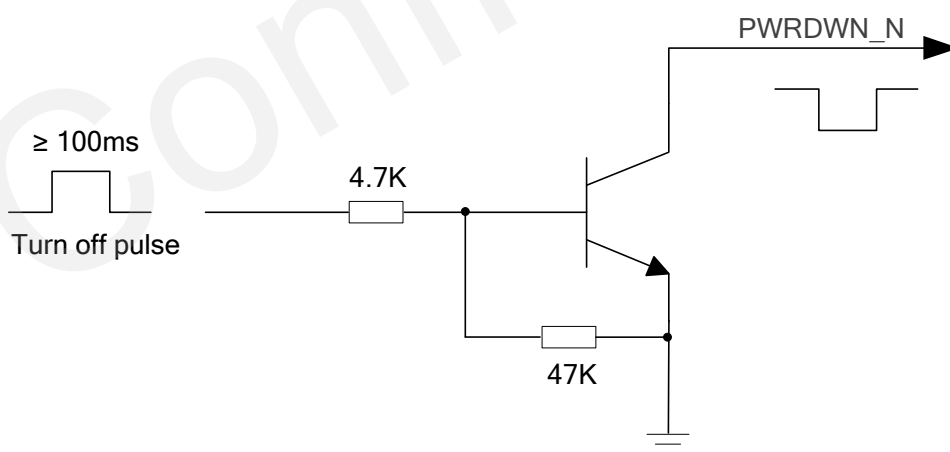

Figure 13: Turn off the Module Using Driving Circuit

The other way to control the PWRDWN_N is using a button directly. A TVS component is indispensable to be placed nearby the button for ESD protection. When pressing the key, electrostatic strike may generate from finger. A reference circuit is showed in the following figure.

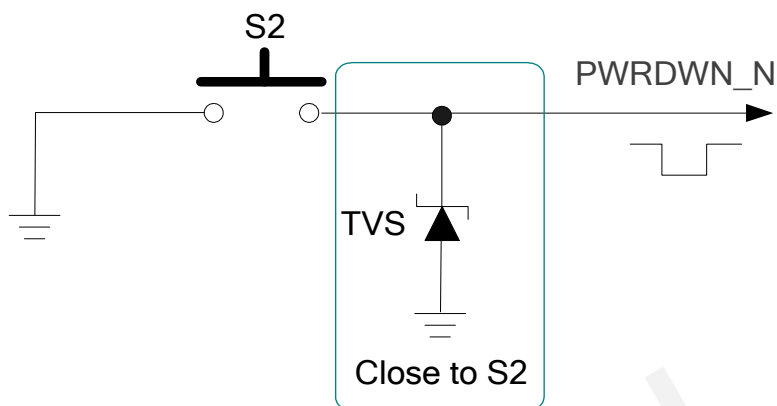

Figure 14: Turn off the Module Using Keystroke

The emergency shutdown scenario is illustrated as the following figure.

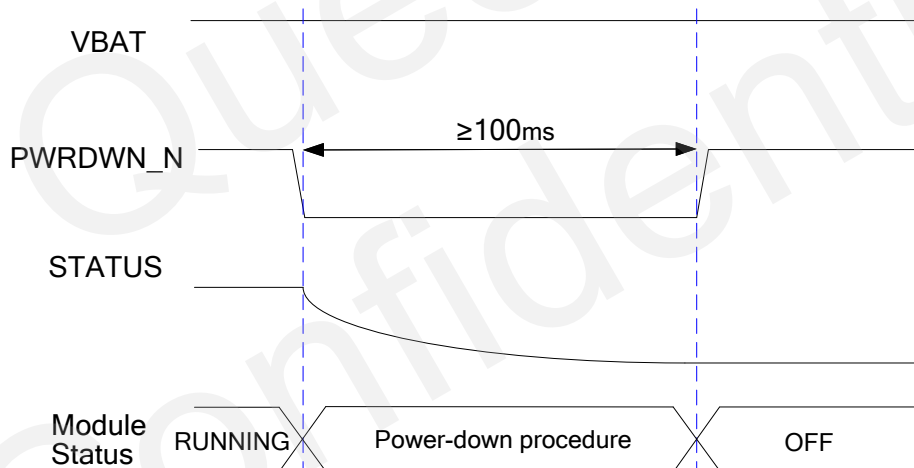

Figure 15: Timing of Emergency Shutdown

NOTE

Use the PWRDWN_N only when turning off the module by the command **AT+QPOWD** or the RESET_N pin failed.

3.7.2.3. Automatic Shutdown

The module will constantly monitor the voltage applied on the VBAT, if the voltage $\leq 3.5V$, the following URC will be presented:

+QIND: "vbatt",-1

If the voltage $\geq 4.21V$, the following URC will be presented:

+QIND: "vbatt",1

The uncritical voltage is 3.3V to 4.3V, If the voltage $> 4.3V$ or $< 3.3V$ the module would automatically shut down itself.

If the voltage $< 3.3V$, the following URC will be presented:

+QIND: "vbatt",-2

If the voltage $> 4.3V$, the following URC will be presented:

+QIND: "vbatt",2

NOTE

The value of voltage threshold can be revised by AT command, refer to **document [1]** for details.

3.8. Reset the Module

The RESET_N can be used to reset the module.

Table 9: RESET_N Pin Description

Pin Name	Pin No.	Description	DC Characteristics	Comment
RESET_N	17	Reset the module	$V_{IHmax}=2.1V$ $V_{IHmin}=1.3V$ $V_{ILmax}=0.5V$	Pull-up to VRTC internally with 200k Ω resistor. Active low.

The module can be reset by driving the RESET_N to a low level voltage for more than 100ms and then releasing.

The recommended circuit is similar to the PWRKEY control circuit. You can use open drain/collector driver or button to control the RESET_N.

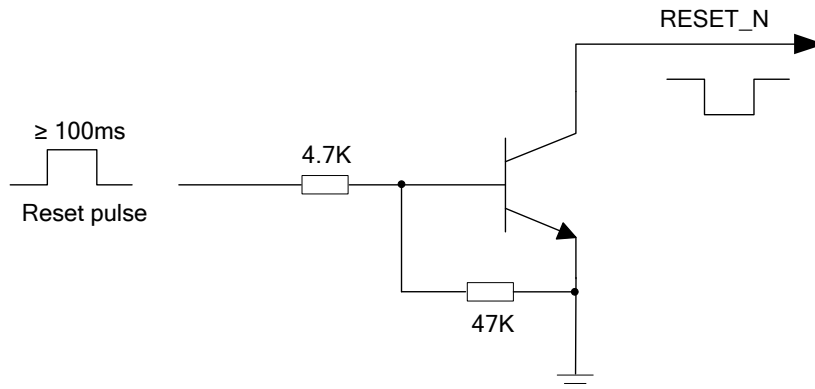

Figure 16: Reference Circuit of RESET_N by Using Driving Circuit

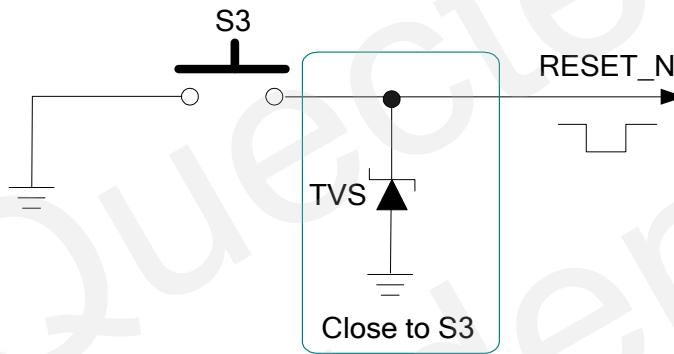

Figure 17: Reference Circuit of RESET_N by Using Button

The reset scenario is illustrated as the following figure.

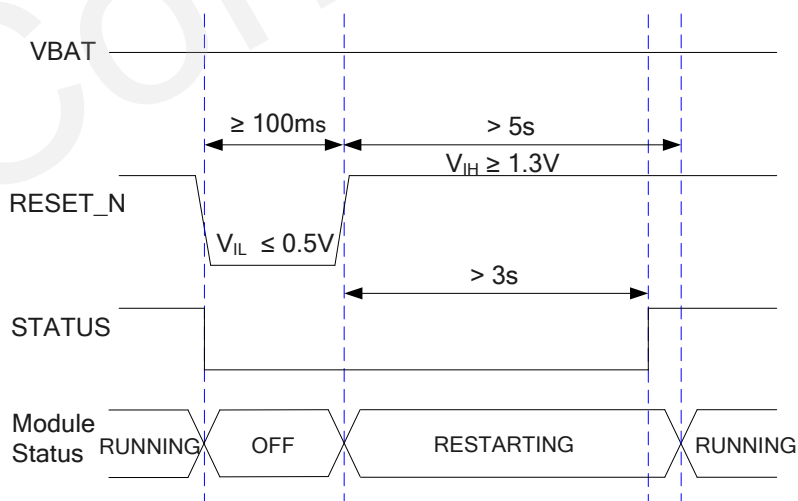

Figure 18: Timing of Resetting Module

3.9. RTC Interface

The RTC (Real Time Clock) can be powered by an external capacitor through the pin VRTC when the module is powered down and there is no power supply for the VBAT. If the voltage supply at VBAT is disconnected, the RTC can be powered by the capacitor. The capacitance determines the duration of buffering when no voltage is applied to UG95.

The capacitor is charged from the internal LDO of UG95 when there is power supply for the VBAT. A serial 1KΩ resistor has been placed on the application inside the module. It limits the input current of the capacitor.

The following figure shows the reference circuit for VRTC backup.

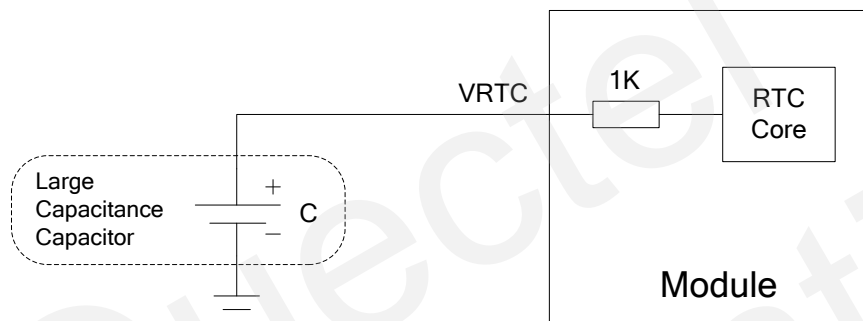

Figure 19: RTC Supply from Capacitor

In order to evaluate the capacitance of capacitor according to the backup time, you have to consider the following parameters:

- VRTC - The starting voltage of the capacitor. (Volt)
- VRTC_{MIN} - The minimum voltage acceptable for the RTC circuit. (Volt)
- I - The current consumption of the RTC circuitry when VBAT=0. (Ampere)
- B_{Time} - Backup Time. (Second)
- C - The backup capacitance. (Farad)

When the power is off and only VRTC is running, the way of calculating the backup capacitor as follows:

$$C = B_{Time} * I / (V_{RTC} - V_{RTC_{MIN}})$$

For example, when the capacitor is 1000uF:

- VRTC=1.8V
- VRTC_{MIN}=1.0V
- I=2uA
- C=1000uF

The backup time is about 400s.

3.10. UART Interface

The module provides 7 lines UART interface.

UART interface supports 300, 1200, 2400, 4800, 9600, 19200, 38400, 57600, 115200, 230400, 460800 and 921600bps baud rate, and the default is auto-baud rate 4800~115200. This interface can be used for data transmission, AT communication or firmware upgrade.

The module is designed as the DCE (Data Communication Equipment), following the traditional DCE-DTE (Data Terminal Equipment) connection. The following table shows the pin definition of UART interface.

Table 10: Pin Definition of the Main UART Interface

Pin Name	Pin No.	I/O	Description	Comment
DTR	30	DI	Data terminal ready	1.8V power domain
RXD	34	DI	Receive data	1.8V power domain
TXD	35	DO	Transmit data	1.8V power domain
CTS	36	DO	Clear to send	1.8V power domain
RTS	37	DI	Request to send	1.8V power domain
DCD	38	DO	Data carrier detection	1.8V power domain
RI	39	DO	Ring indicator	1.8V power domain

The logic levels are described in the following table.

Table 11: Logic Levels of Digital I/O

Parameter	Min.	Max.	Unit
V_{IL}	-0.3	0.35	V
V_{IH}	1.3	1.85	V
V_{OL}	0	0.25	V
V_{OH}	1.55	1.8	V

UG95 provides one 1.8V UART interface. A level shifter should be used if your application is equipped with a 3.3V UART interface. A level shifter TXS0108EPWR provided by **Texas Instruments** is recommended. The following figure shows the reference design of the TXS0108EPWR.

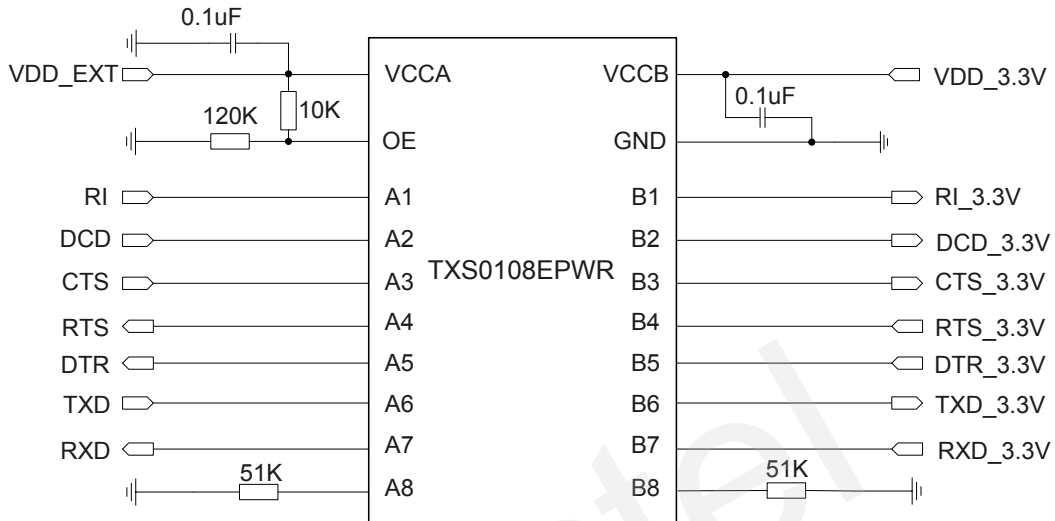

Figure 20: Reference Circuit of Logic Level Translator

Please visit <http://www.ti.com> for more information.

Another example with transistor translation circuit is shown as below. The circuit of dotted line can refer to the circuit of solid line. Please pay attention to direction of connection. Input dotted line of module should refer to input solid line of the module. Output dotted line of module should refer to output solid line of the module. The transistor translation circuit supports a maximum data rate of 0.5Mbps.

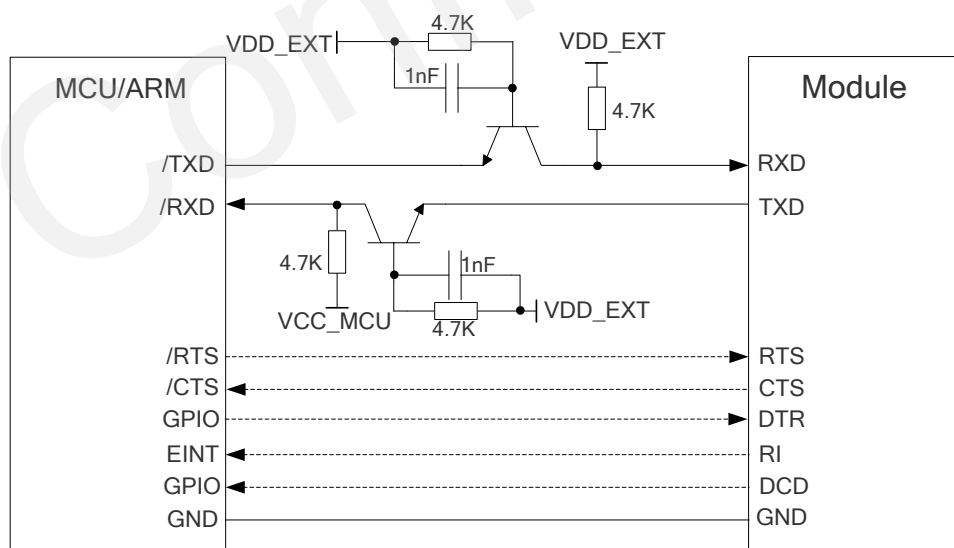

Figure 21: Reference Circuit with Transistor Circuit

The following figure is an example of connection between UG95 and PC. A voltage level translator and a RS-232 level translator chip must be inserted between module and PC, since the UART interface does not support the RS-232 level, while supports the 1.8V CMOS level only.

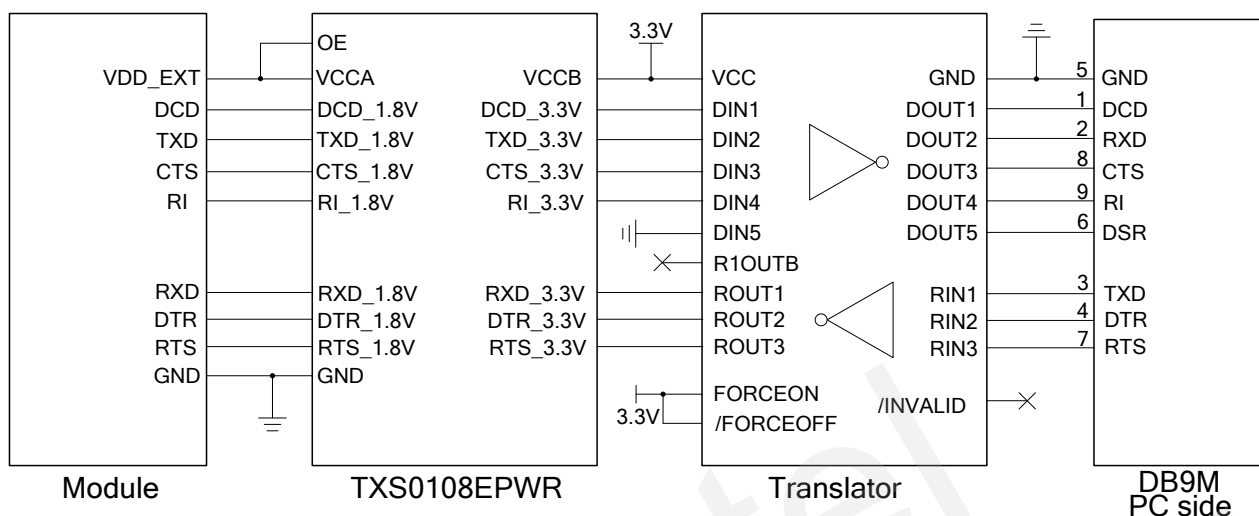

Figure 22: RS232 Level Match Circuit

NOTES

1. The module disables the hardware flow control by default. When hardware flow control is required, RTS and CTS should be connected to the host. AT command **AT+IFC=2,2** is used to enable hardware flow control. AT command **AT+IFC=0,0** is used to disable the hardware flow control. For more details, please refer to **document [1]**.
2. Rising edge on DTR will let the module exit from the data mode by default. It can be disabled by AT commands. Refer to **document [1]** for details.
3. DCD is used as data mode indication. Refer to **document [1]** for details.
4. It is suggested that you should set USB_DP, USB_DM and USB_VBUS pins as test points and then place these test points on the DTE for debug.

3.11. USIM Card Interface

The USIM card interface circuitry meets ETSI and IMT-2000 SIM interface requirements. Both 1.8V and 3.0V USIM cards are supported.

Table 12: Pin Definition of the USIM Interface

Pin Name	Pin No.	I/O	Description	Comment
USIM_PRESENCE	42	DI	USIM card detection input.	1.8V power domain.
USIM_VDD	43	PO	Power supply for USIM card.	Either 1.8V or 3.0V is supported by the module automatically.
USIM_RST	44	DO	Reset signal of USIM card.	
USIM_DATA	45	IO	Data signal of USIM card.	Pull-up to USIM_VDD with 4.7k resistor internally.
USIM_CLK	46	DO	Clock signal of USIM card.	
USIM_GND	47		Specified ground for USIM card.	

UG95 supports USIM card hot-plugging via the USIM_PRESENCE pin. The following figure shows the reference design of the 8-pin USIM card.

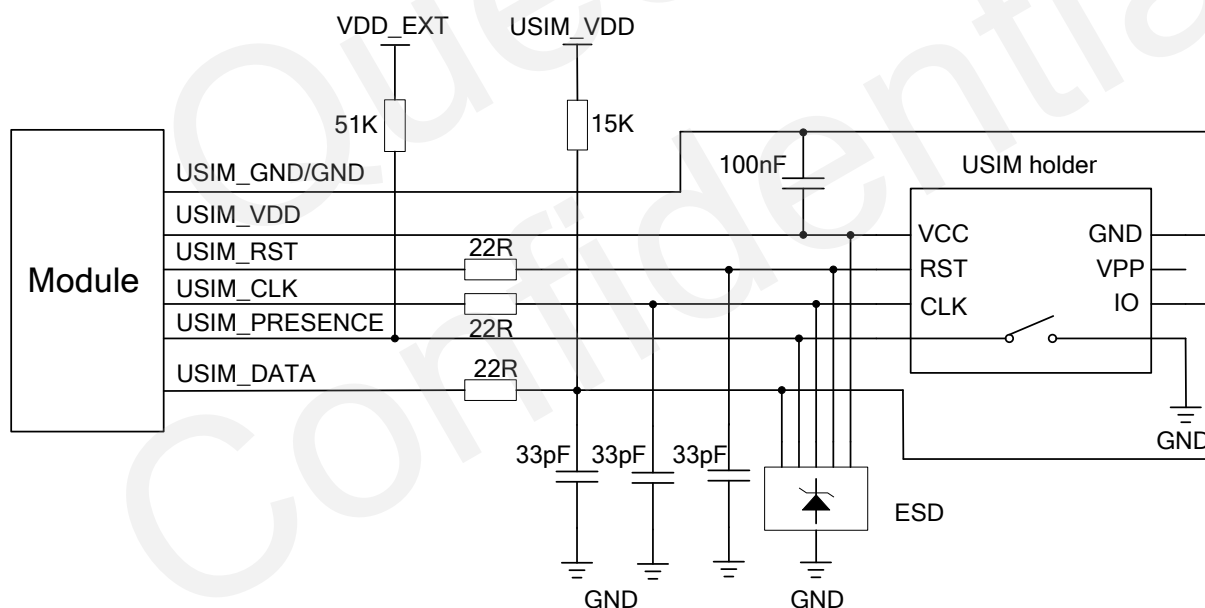

Figure 23: Reference Circuit of the 8-Pin USIM Card

If you do not need the USIM card detection function, keep USIM_PRESENCE unconnected. The reference circuit for using a 6-pin USIM holder is illustrated as the following figure.

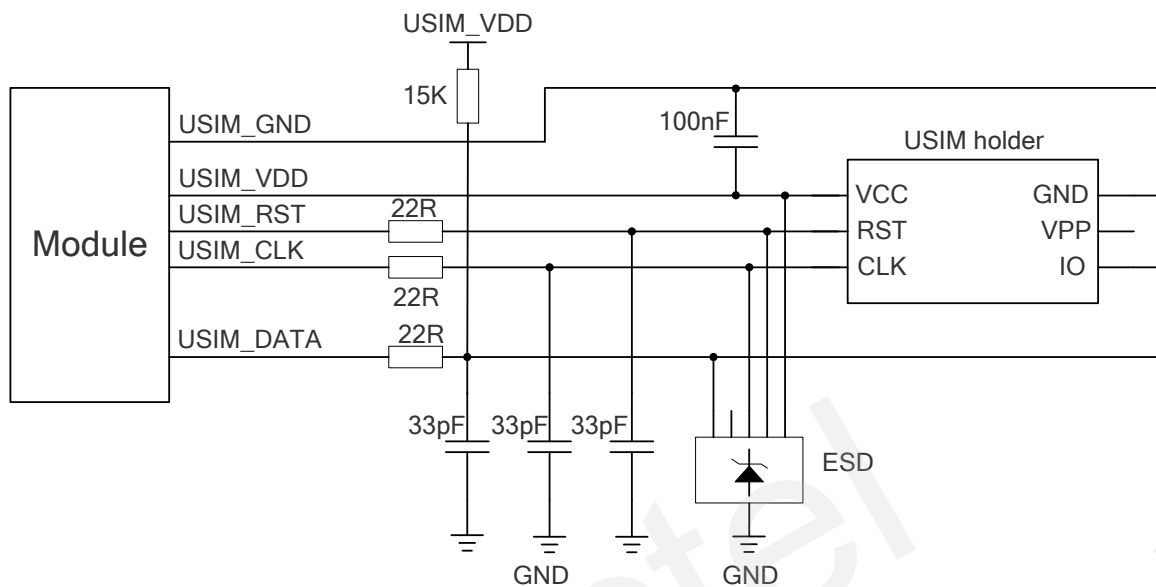

Figure 24: Reference Circuit of the 6-Pin USIM Card

In order to enhance the reliability and availability of the USIM card in customer's application, please follow the criteria below in the USIM circuit design:

- Keep layout of USIM card as close as possible to the module. Assure the length of the trace is as less than 200mm as possible.
- Keep USIM card signal away from RF and VBAT alignment.
- Assure the ground between module and USIM holder short and wide. Keep the width of ground and USIM_VDD no less than 0.5mm to maintain the same electric potential. The decouple capacitor of USIM_VDD should be less than 1uF and must be near to USIM holder.
- To avoid cross-talk between USIM_DATA and USIM_CLK, keep them away with each other and shield them with surrounded ground.
- In order to offer good ESD protection, it is recommended to add TVS such as WILL (<http://www.willsemi.com>). The 22Ω resistors should be added in series between the module and the USIM card so as to suppress the EMI spurious transmission and enhance the ESD protection. The 33pF capacitors are used for filtering interference of EGSM900. Please note that the USIM peripheral circuit should be close to the USIM holder.
- The pull-up resistor on USIM_DATA line can improve anti-jamming capability when long layout trace and sensitive occasion is applied, and should be placed close to the USIM holder.

3.12. USB Interface

UG95 contains one integrated Universal Serial Bus (USB) transceiver which complies with the USB 1.1/2.0 specification and supports high speed (480Mbps) and full speed (12Mbps) mode. The USB interface is primarily used for AT command, data transmission, software debug and firmware upgrade. The following table shows the pin definition of USB interface.

Table 13: USB Pin Description

Pin Name	Pin No.	I/O	Description	Comment
USB_DP	9	IO	USB differential data bus (positive).	Require differential impedance of 90Ω.
USB_DM	10	IO	USB differential data bus (minus).	Require differential impedance of 90Ω.
USB_VBUS	8	PI	Used for detecting the USB interface connected.	2.5~5.25V. Typical 5.0V.

More details about the USB 2.0 specifications, please visit <http://www.usb.org/home>.

The following figure shows the reference circuit of USB interface.

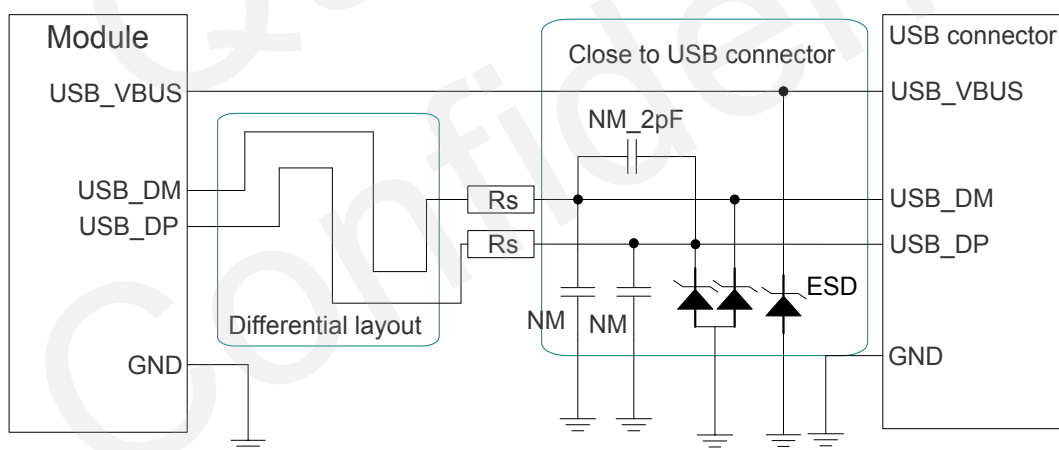

Figure 25: Reference Circuit of USB Application

In order to ensure the USB interface design corresponding with the USB 2.0 specification, please comply with the following principles:

- It is important to route the USB signal traces as differential pairs with total grounding. The impedance of USB differential trace is 90ohm.
- Pay attention to the influence of junction capacitance of ESD component on USB data lines. Typically, the capacitance value should be less than 2pF.
- Do not route signal traces under crystals, oscillators, magnetic devices and RF signal traces. It is important to route the USB differential traces in inner-layer with ground shielding not only upper and lower layer but also right and left side.
- Keep the ESD components as close as possible to the USB connector.
- It is suggested that a RC circuit should be reserved near USB connector for debug.

The USB interface is recommended to be reserved for firmware upgrade in your design. The following figure shows the recommended test points.

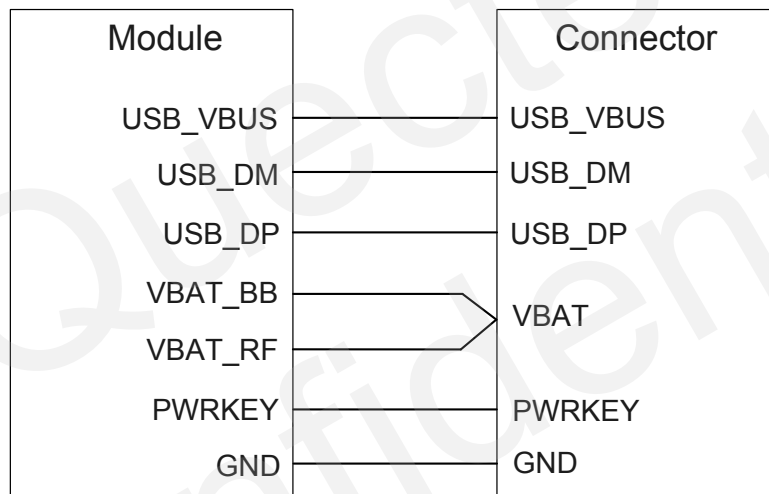

Figure 26: Test Points of Firmware Upgrade

NOTES

1. UG95 module can only be used as a slave device.
2. It is suggested that you should set USB_DP, USB_DM and USB_VBUS pins as test points and then place these test points on the DTE for debug.
3. USB interface supports software debug and firmware upgrade by default.

3.13. PCM and I2C Interface

UG95 provides one Pulse Code Modulation (PCM) digital interface for audio design, which supports the following features:

- Supports 8, 16, 32 bit mode with short frame synchronization, the PCM support 8 bit mode by default. The PCM codec default configuration is **AT+QDAC=1**. Refer to **document [1]** for more details.
- Supports master mode.
- Supports audio sample rate 8 kHz.

The following table shows the pin definition of PCM and I2C interface.

Table 14: Pin Definition of PCM and I2C Interface

Pin Name	Pin No.	I/O	Description	Comment
PCM_CLK	4	DO	PCM data bit clock	1.8V power domain
PCM_SYNC	5	DO	PCM data frame sync signal	1.8V power domain
PCM_IN	6	DI	PCM data input	1.8V power domain
PCM_OUT	7	DO	PCM data output	1.8V power domain
I2C_SCL	40	OD	I2C serial clock	Require external pull-up resistor
I2C_SDA	41	OD	I2C serial data	Require external pull-up resistor
CLK_OUT	25	DO	Clock output	Provide a digital clock output for an external audio codec. If unused, keep this pin open.

In PCM audio format the MSB of the channel included in the frame (PCM_SYNC) is clocked on the second CLK falling edge after the PCM_SYNC pulse rising edge. The period of the PCM_SYNC signal (frame) lasts for Data word bit +1 clock pulses.

UG95's firmware has integrated the configuration on NAU8814/ALC5616/MAX9860 application with I2C interface. **AT+QDAC** command is used to configure the external codec chip linked with PCM interface, and refer to **document [1]** for more details. Data bit is 32 bit and the sampling rate is 8 KHz. The following figure shows the timing of the application with ALC5616 codec.

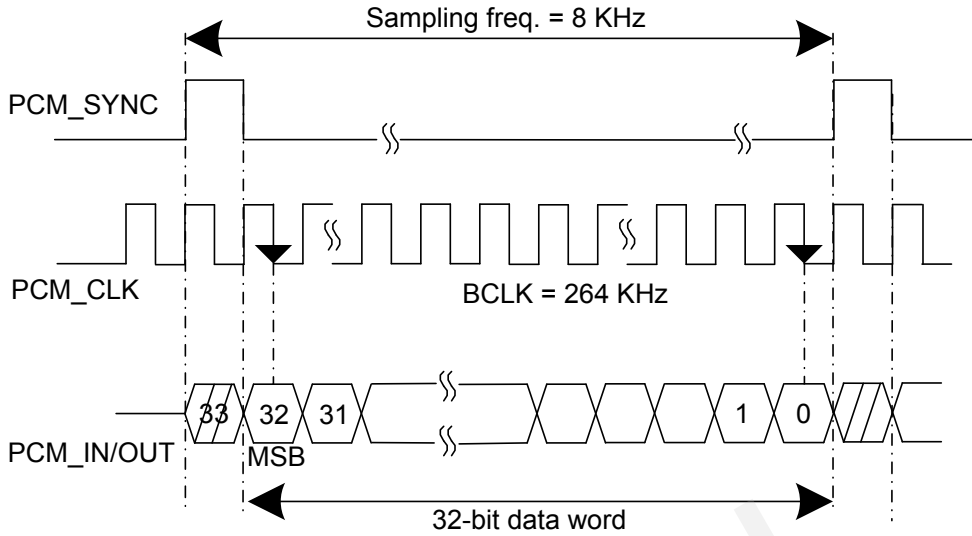

Figure 27: PCM Master Mode Timing

In general, the BitClockFrequency (BCLK) is furnished by the following expression:

$$\text{BitClockFrequency} = (\text{DataWordBit} + 1) \times \text{SamplingFrequency}$$

The following figure shows the reference design of PCM interface with external codec IC.

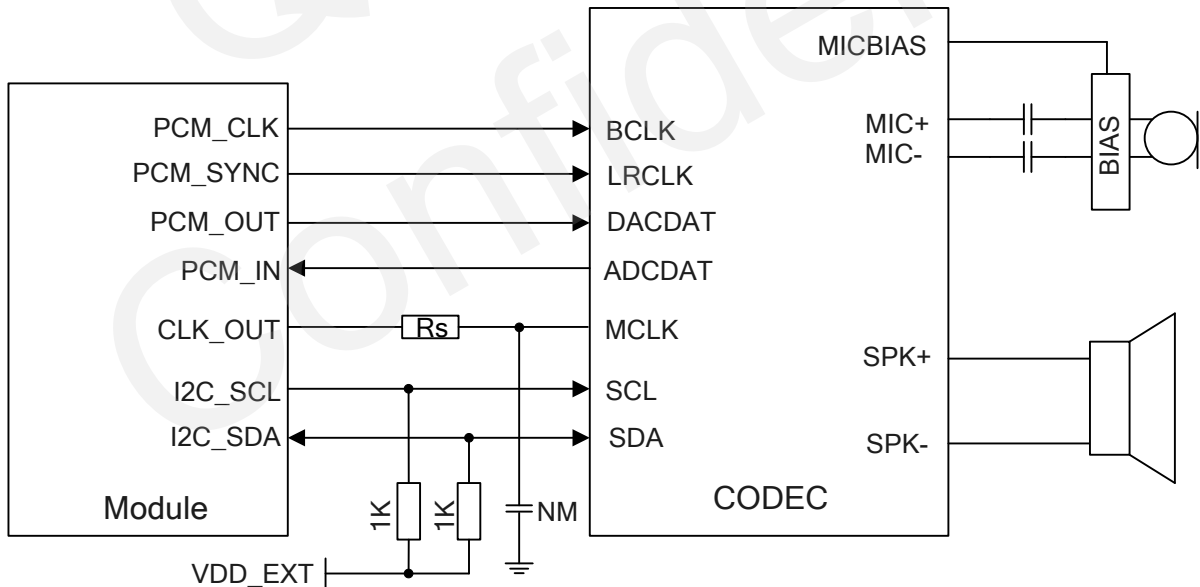

Figure 28: Reference Circuit of PCM Application with Audio Codec

NOTES

1. It is recommended to reserve RC (R=22Ω, C=22pF) circuit on the PCM lines, especially for PCM_CLK.
2. UG95 module provides a digital clock output (CLK_OUT) for an external audio codec, the CLK_OUT function is disabled by default. When CLK_OUT is required, AT command is used to provide the codec with a 13/26MHz clock generated from the module. Refer to **document [1]** for details. If unused, keep this pin open.
3. A RC (e.g. R=22Ω, C=47pF) circuit is recommended to be reserved on CLK_OUT line. If external audio CODEC is MAX9860 or NAU8814, the RC circuit should be mounted, if it is ALC5616, then it is not mounted.

3.14. Network Status Indication

The NETLIGHT signal can be used to drive a network status indication LED. The following tables describe pin definition and logic level changes in different network status.

Table 15: Pin Definition of Network Indicator

Pin Name	Pin No.	I/O	Description	Comment
NETLIGHT	21	DO	Indicate the module network activity status.	1.8V power domain

Table 16: Working State of the Network Indicator

Pin Name	Status	Description
	PWM (200ms High/1800ms Low)	Networks searching
NETLIGHT	PWM (1800ms High/200ms Low)	Idle&Data transfer
	Always High	Voice&CSD calling

A reference circuit is shown in the following figure.

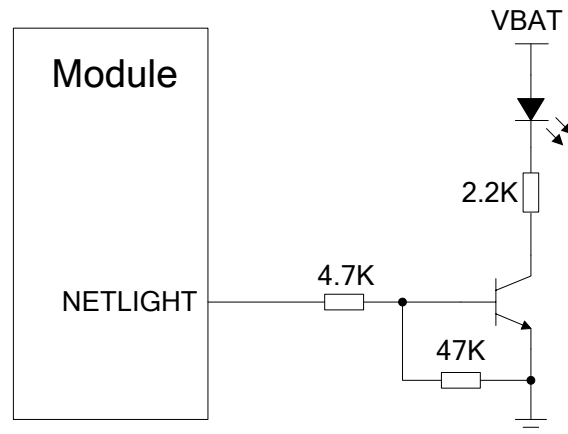

Figure 29: Reference Circuit of the NETLIGHT

3.15. Operating Status Indication

The STATUS pin is set as the module status indicator. It will output high level when module is powered on.

The following table describes pin definition of STATUS.

Table 17: Pin Definition of STATUS

Pin Name	Pin No.	I/O	Description	Comment
STATUS	20	DO	Indicate the module operation status	1.8V power domain

A reference circuit is shown as below.

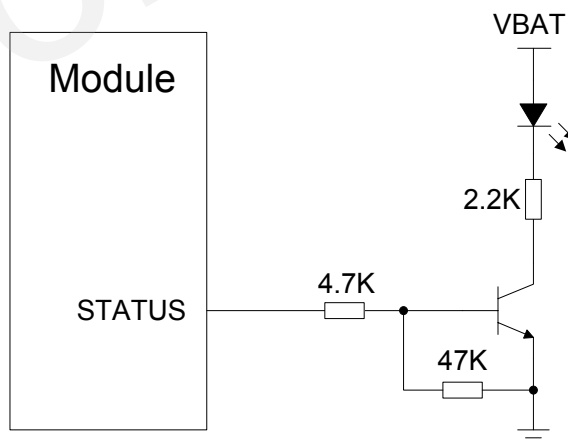

Figure 30: Reference Circuit of the STATUS

4 Antenna Interface

The Pin 60 is the RF antenna pad. The RF interface has an impedance of 50Ω.

4.1. GSM/UMTS Antenna Interface

4.1.1. Pin Definition

Table 18: Pin Definition of the RF Antenna

Pin Name	Pin No.	I/O	Description	Comment
GND	58		ground	
GND	59		ground	
RF_ANT	60	IO	RF antenna pad	50Ω impedance
GND	61		ground	
GND	62		ground	

4.1.2. Operating Frequency

Table 19: The Module Operating Frequencies

Band	Receive	Transmit	Unit
EGSM900	925 ~ 960	880 ~ 915	MHz
DCS1800	1805 ~ 1880	1710 ~ 1785	MHz
UMTS2100	2110 ~ 2170	1920 ~ 1980	MHz
UMTS1900	1930 ~ 1990	1850 ~ 1910	MHz
UMTS900	925 ~ 960	880 ~ 915	MHz
UMTS850	869 ~ 894	824 ~ 849	MHz

4.1.3. Reference Design

The RF external circuit is recommended as below. It should reserve a π -type matching circuit for better RF performance. The capacitors are not mounted by default.

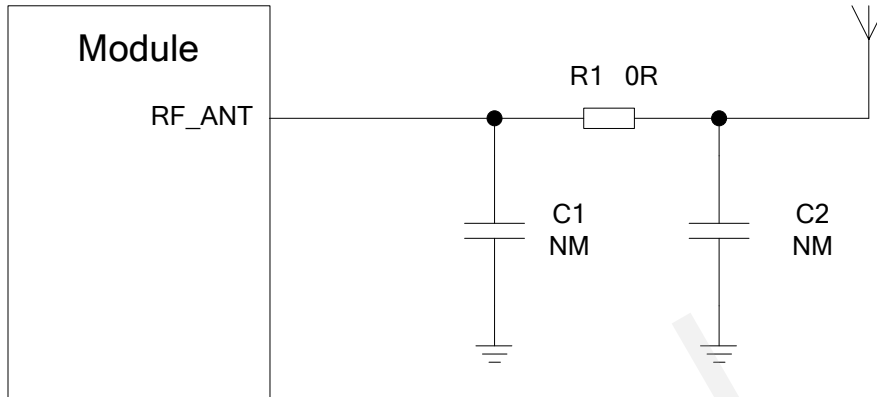

Figure 31: Reference Circuit of Antenna Interface

UG95 provides an RF antenna PAD for customer's antenna connection. The RF trace in host PCB connected to the module RF antenna pad should be micro-strip line or other types of RF trace, whose characteristic impedance should be close to 50Ω. UG95 comes with grounding pads which are next to the antenna pad in order to give a better grounding.

4.2. Antenna Installation

4.2.1. Antenna Requirement

The following table shows the requirement on GSM/UMTS antenna.

Table 20: Antenna Cable Requirements

Type	Requirements
EGSM900 UMTS850/900	Cable insertion loss <1dB
DCS1800 UMTS1900/2100	Cable insertion loss <1.5dB

Table 21: Antenna Requirements

Type	Requirements
Frequency Range	UG95-A: UMTS Dual-band: 850/1900MHz UG95-E: GSM Dual-band: 900/1800MHz UMTS Dual-band: 900/2100MHz
VSWR	<2:1 recommended, <3:1 acceptable
Gain (dBi)	1 typical
Max Input Power (W)	50
Input Impedance (Ω)	50
Polarization Type	Vertical

4.2.2. Install the Antenna with RF Connector

The following figure is the antenna installation with RF connector provided by HIROSE. The recommended RF connector is UF.L-R-SMT.

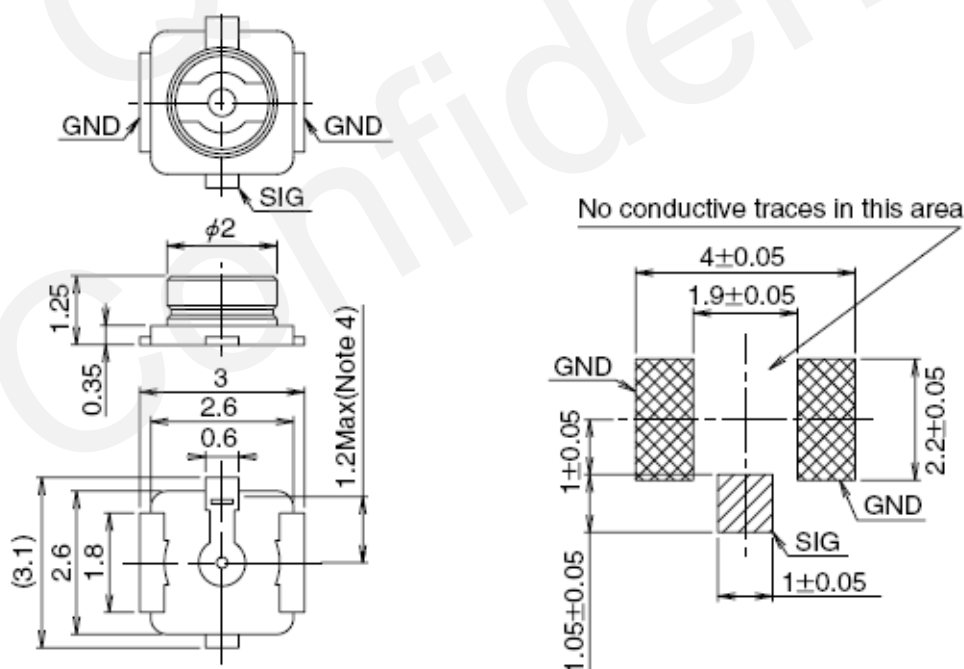

Figure 32: Dimensions of the UF.L-R-SMT Connector (Unit: mm)

You can use U.FL-LP serial connector listed in the following figure to match the UF.L-R-SMT.

Part No.	U.FL-LP-040	U.FL-LP-066	U.FL-LP(V)-040	U.FL-LP-062	U.FL-LP-088
Mated Height	2.5mm Max. (2.4mm Nom.)	2.5mm Max. (2.4mm Nom.)	2.0mm Max. (1.9mm Nom.)	2.4mm Max. (2.3mm Nom.)	2.4mm Max. (2.3mm Nom.)
Applicable cable	Dia. 0.81mm Coaxial cable	Dia. 1.13mm and Dia. 1.32mm Coaxial cable	Dia. 0.81mm Coaxial cable	Dia. 1mm Coaxial cable	Dia. 1.37mm Coaxial cable
Weight (mg)	53.7	59.1	34.8	45.5	71.7
RoHS	YES				

Figure 33: Mechanicals of UF.L-LP Connectors (Unit: mm)

The following figure describes the space factor of mated connector

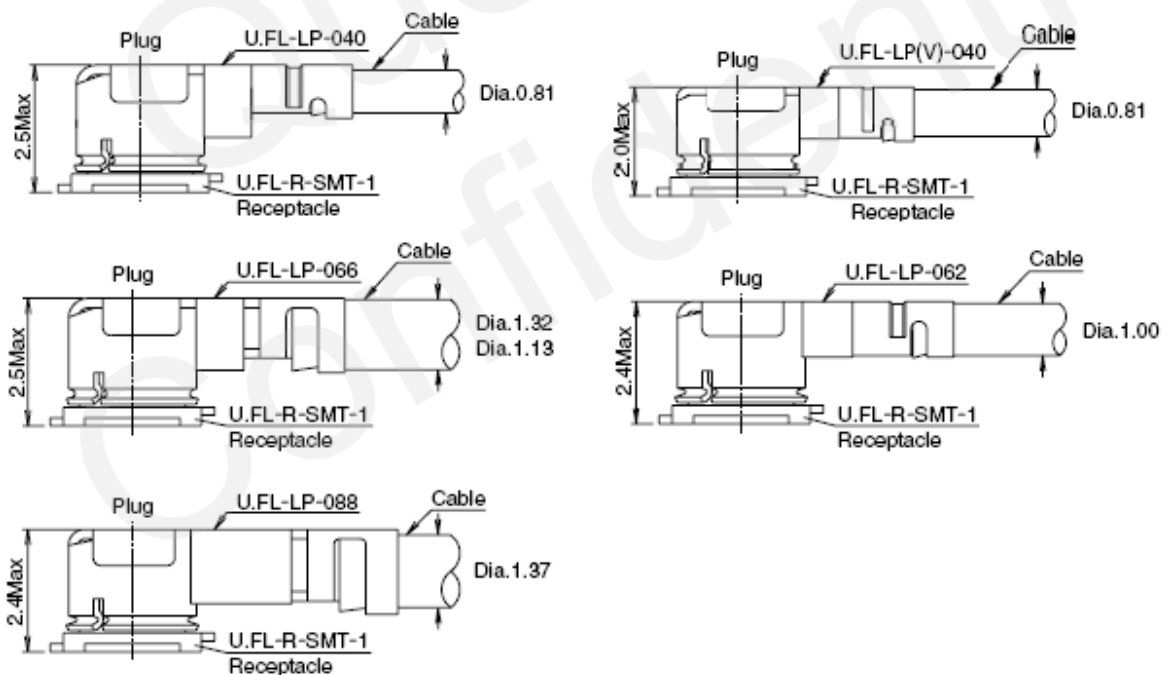

Figure 34: Space Factor of Mated Connector (Unit: mm)

For more details, please visit <http://www.hirose.com>.

5 Electrical, Reliability and Radio Characteristics

5.1. Absolute Maximum Ratings

Absolute maximum ratings for power supply and voltage on digital and analog pins of module are listed in the following table.

Table 22: Absolute Maximum Ratings

Parameter	Min.	Max.	Unit
VBAT_RF/VBAT_BB	-0.3	4.7	V
USB_VBUS	-0.3	5.5	V
Peak Current of VBAT_BB	0	0.8	A
Peak Current of VBAT_RF	0	2	A
Voltage at Digital Pins	-0.3	2.3	V

5.2. Power Supply Ratings

Table 23: The Module Power Supply Ratings

Parameter	Description	Conditions	Min.	Typ.	Max.	Unit
VBAT	VBAT_BB and VBAT_RF	Voltage must stay within the min/max values, including voltage drop, ripple, and spikes.	3.3	3.8	4.3	V
	Voltage drop during transmitting burst	Maximum power control level on EGSM900.			400	mV

Parameter	Description	Conditions	Min.	Typ.	Max.	Unit
I _{BAT}	Peak supply current (during transmission slot)	Maximum power control level on EGSM900.		1.8	2.0	A
USB_VBUS	USB insert detection		2.5	5.0	5.25	V

5.3. Operating Temperature

The operating temperature is listed in the following table.

Table 24: Operating Temperature

Parameter	Min.	Typ.	Max.	Unit
Normal Temperature	-35	25	80	°C
Restricted Operation ¹⁾	-40~ -35		80 ~ 85	°C
Storage Temperature	-45		90	°C

NOTE

¹⁾ When the module works within the temperature range, the deviations from the RF specification may occur. For example, the frequency error or the phase error would increase.

5.4. Current Consumption

The values of current consumption are shown as below.

Table 25: The Module Current Consumption

Parameter	Description	Conditions	Min.	Typ.	Max.	Unit
I _{BAT}	OFF state supply current	Power down		70		uA
	GSM/GPRS	Sleep (USB disconnected)		1.45		mA

Parameter	Description	Conditions	Min.	Typ.	Max.	Unit
	supply current	@DRX=2				
		Sleep (USB disconnected) @DRX=5		1.12		mA
		Sleep (USB disconnected) @DRX=9		0.96		mA
		Sleep (USB disconnected) @DRX=6		1.98		mA
		Sleep (USB disconnected) @DRX=7		1.46		mA
		Sleep (USB disconnected) @DRX=8		1.24		mA
	WCDMA supply current	Sleep (USB disconnected) @DRX=9		1.15		mA
		Idle (USB disconnected) @DRX=6		12		mA
		Idle (USB connected) @DRX=6		31.7		mA
		EGSM900 1DL/1UL PCL=5		201		mA
		EGSM900 4DL/1UL PCL=5		211		mA
		EGSM900 3DL/2UL PCL=5		337		mA
		EGSM900 2DL/3UL PCL=5		425		mA
		EGSM900 1DL/4UL PCL=5		490		mA
	GPRS data transfer	DCS1800 1DL/1UL PCL=0		137		mA
		DCS1800 4DL/1UL PCL=0		160		mA
		DCS1800 3DL/2UL PCL=0		236		mA
		DCS1800 2DL/3UL PCL=0		293		mA
		DCS1800 1DL/4UL PCL=0		335		mA
		UMTS2100 HSDPA @max power		524		mA
		UMTS2100 HSUPA @max power		536		mA
	WCDMA data transfer	UMTS1900 HSDPA @max power		522		mA
		UMTS1900 HSUPA @max power		563		mA

Parameter	Description	Conditions	Min.	Typ.	Max.	Unit
		UMTS850 HSDPA @max power		490		mA
		UMTS850 HSUPA @max power		520		mA
		UMTS900 HSDPA @max power		510		mA
		UMTS900 HSUPA @max power		512		mA
	GSM voice call	EGSM900 @PCL=5		212		mA
		EGSM900 @PCL=12		90		mA
		EGSM900 @PCL=19		67		mA
		DCS1800 @PCL=0		159		mA
		DCS1800 @PCL=7		77		mA
		DCS1800 @PCL=15		62		mA
		WCDMA voice call	UMTS2100 @max power		586	
	UMTS1900 @max power			566		mA
	UMTS850 @max power			535		mA
	UMTS900 @max power			561		mA

5.5. RF Output Power

The following table shows the RF output power of UG95 module.

Table 26: Conducted RF Output Power

Frequency	Max.	Min.
EGSM900	33dBm±2dB	5dBm±5dB
DCS1800	30dBm±2dB	0dBm±5dB
UMTS2100	24dBm+1.7/-3.7dB	<-50dBm
UMTS1900	24dBm+1.7/-3.7dB	<-50dBm

UMTS900	24dBm+1.7/-3.7dB	<-50dBm
UMTS850	24dBm+1.7/-3.7dB	<-50dBm

NOTE

In GPRS 4 slots TX mode, the max output power is reduced by 3dB. This design conforms to the GSM specification as described in chapter 13.16 of 3GPP TS 51.010-1.

5.6. RF Receiving Sensitivity

The following table shows the conducted RF receiving sensitivity of UG95 module.

Table 27: Conducted RF Receiving Sensitivity

Frequency	Receive Sensitivity (Typ.)
EGSM900	-109.5dBm
DCS1800	-110.5dBm
UMTS2100	-110dBm
UMTS1900	-110.5dBm
UMTS900	-110dBm
UMTS850	-110.5dBm

5.7. Electrostatic Discharge

The module is not protected against electrostatics discharge (ESD) in general. Consequently, it is subject to ESD handling precautions that typically apply to ESD sensitive components. Proper ESD handling and packaging procedures must be applied throughout the processing, handling and operation of any application that incorporates the module.

6 Mechanical Dimensions

This chapter describes the mechanical dimensions of the module. All dimensions are measured in mm.

6.1. Mechanical Dimensions of the Module

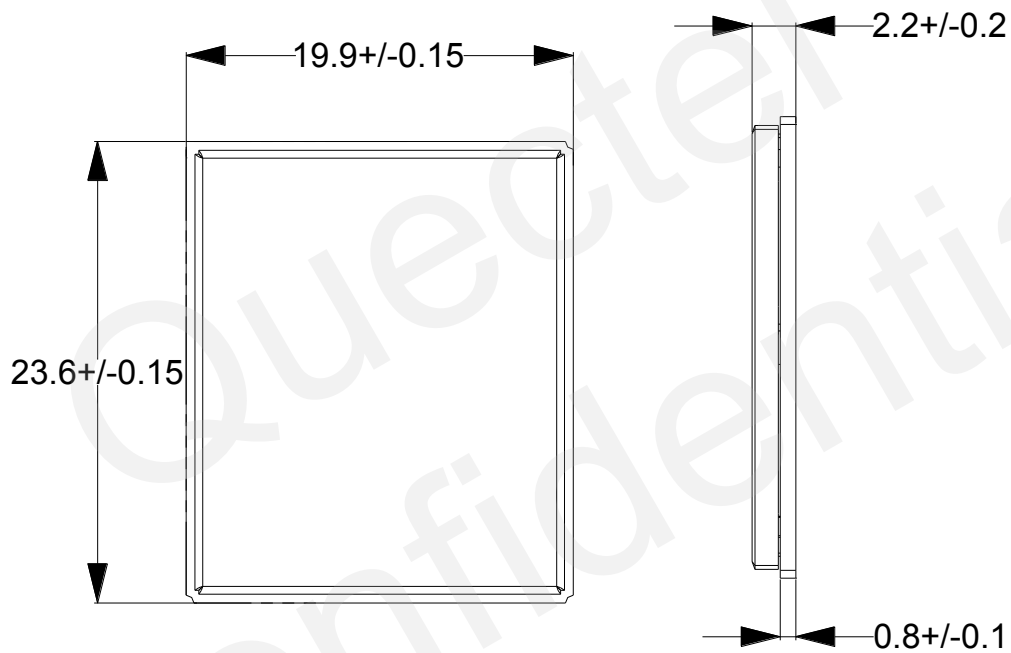

Figure 35: UG95 Top and Side Dimensions

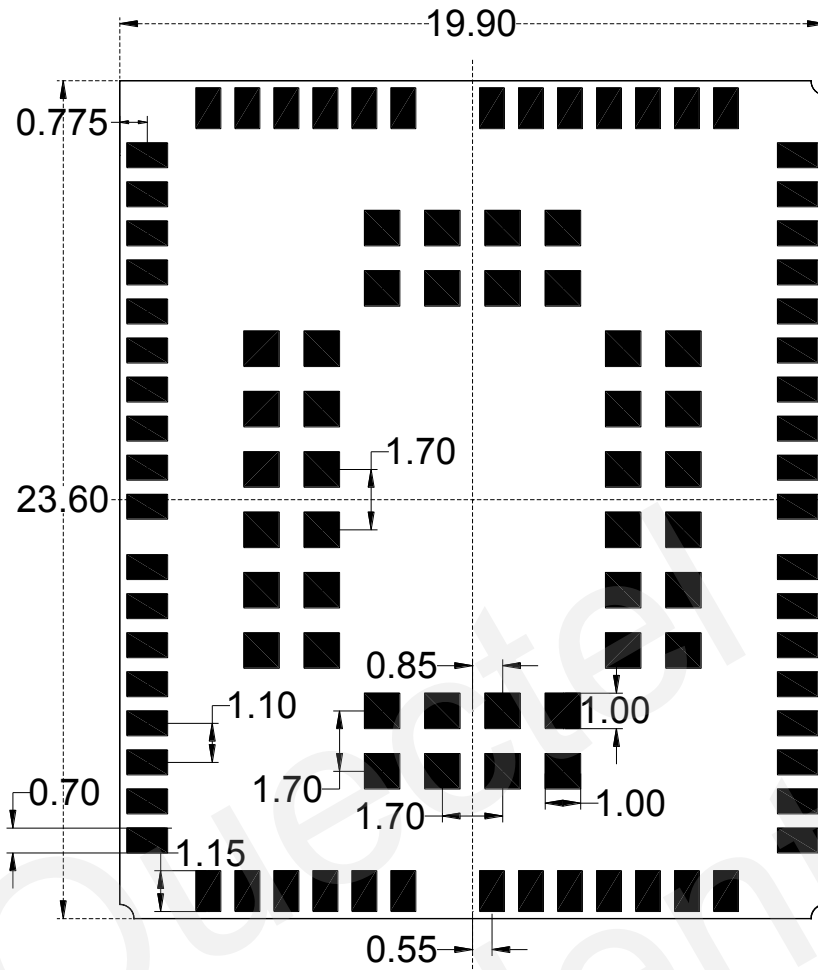

Figure 36: UG95 Bottom Dimension (Top View)

The recommended stencil of UG95 is showed as below.

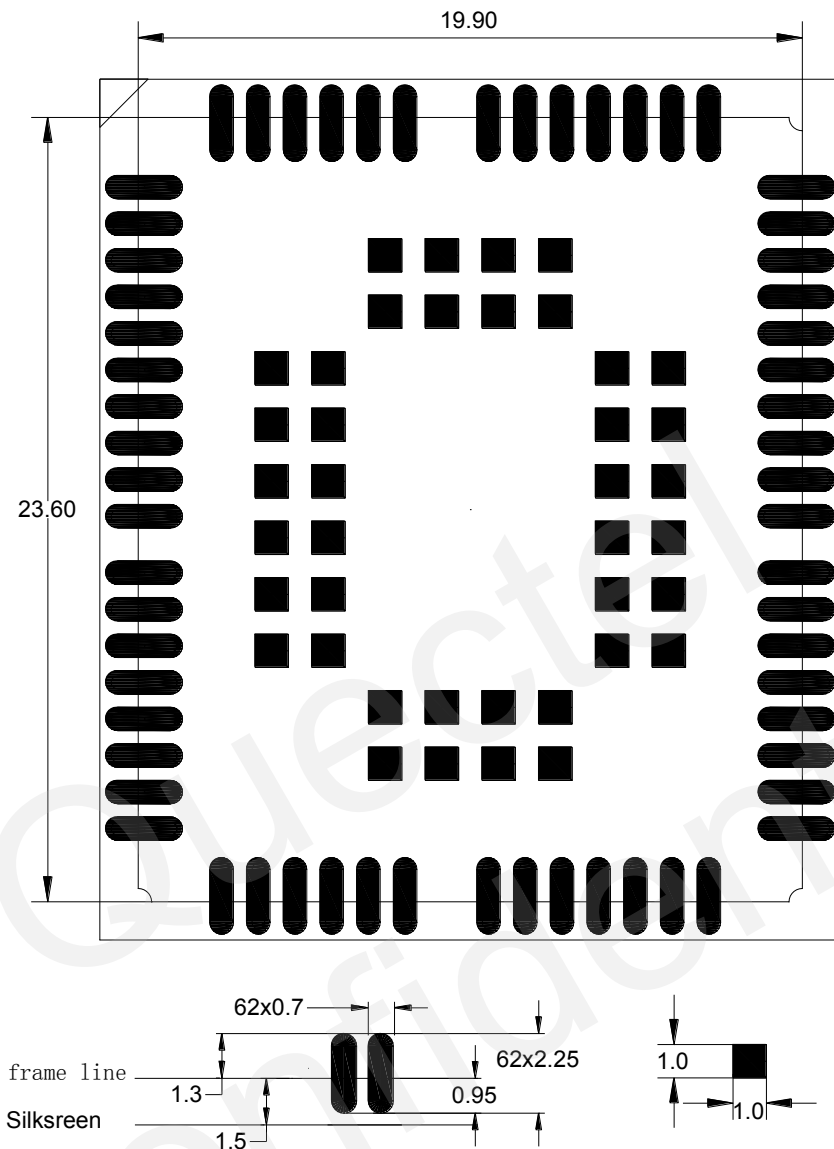

Figure 38: Recommended Stencil of UG95 (Top View)

NOTES

1. In order to maintain the module, keep about 3mm between the module and other components in the host PCB.
2. All RESERVED pins must not be connected to GND.
3. All dimensions are in millimeters.

6.3. Top View of the Module



Figure 39: Top View of the Module

6.4. Bottom View of the Module

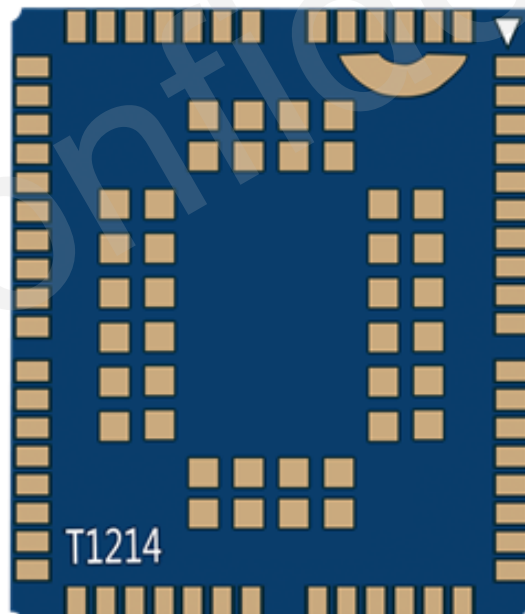

Figure 40: Bottom View of the Module

7 Storage and Manufacturing

7.1. Storage

UG95 is stored in the vacuum-sealed bag. The restriction of storage condition is shown as below.

Shelf life in sealed bag is 12 months at $< 40^{\circ}\text{C}/90\%\text{RH}$.

After this bag is opened, devices that will be subjected to reflow solder or other high temperature process must be:

- Mounted within 72 hours at factory conditions of $\leq 30^{\circ}\text{C}/60\%\text{RH}$.
- Stored at $<10\% \text{RH}$.

Devices require bake, before mounting, if:

- Humidity indicator card is $>10\%$ when read $23^{\circ}\text{C}\pm 5^{\circ}\text{C}$.
- Mounted for more than 72 hours at factory conditions of $\leq 30^{\circ}\text{C}/60\% \text{RH}$.

If baking is required, devices may be baked for 48 hours at $125^{\circ}\text{C}\pm 5^{\circ}\text{C}$.

NOTE

As plastic container cannot be subjected to high temperature, module needs to be taken out from container to high temperature (125°C) bake. If shorter bake times are desired, please refer to IPC/JEDECJ-STD-033 for bake procedure.

7.2. Manufacturing and Welding

The squeegee should push the paste on the surface of the stencil that makes the paste fill the stencil openings and penetrate to the PCB. The force on the squeegee should be adjusted so as to produce a clean stencil surface on a single pass. To ensure the module soldering quality, the thickness of stencil at the hole of the module pads should be 0.13mm. For details, please refer to **document [6]**.

It is suggested that peak reflow temperature is 235 ~ 245°C (for SnAg3.0Cu0.5 alloy). Absolute max reflow temperature is 260°C. To avoid damage to the module when it was repeatedly heated, it is suggested that the module should be mounted after the first panel has been reflowed. The following picture is the actual diagram which we have operated.

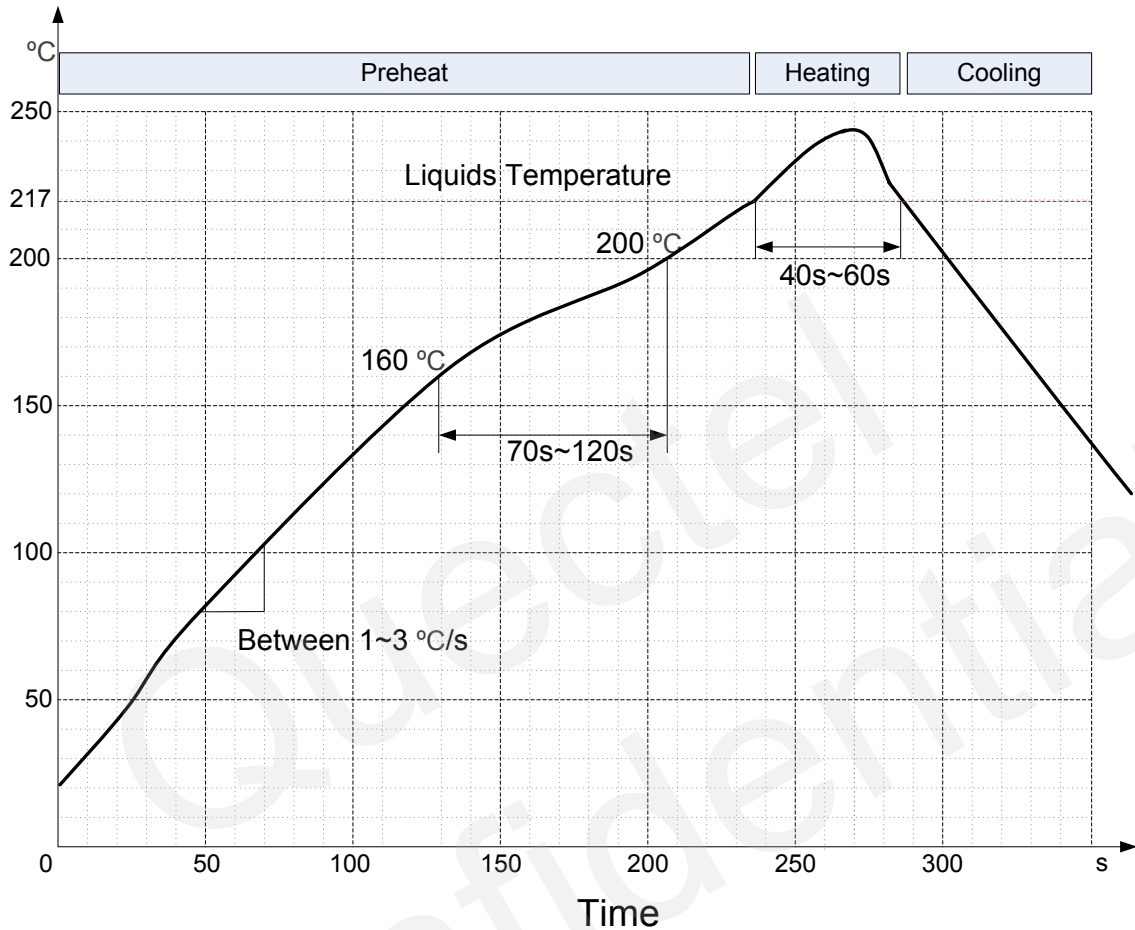

Figure 41: Reflow Soldering Profile

7.3. Packaging

The modules are stored inside a vacuum-sealed bag which is ESD protected. It should not be opened until the devices are ready to be soldered onto the application.

The reel is 330mm in diameter and each reel contains 250 modules.

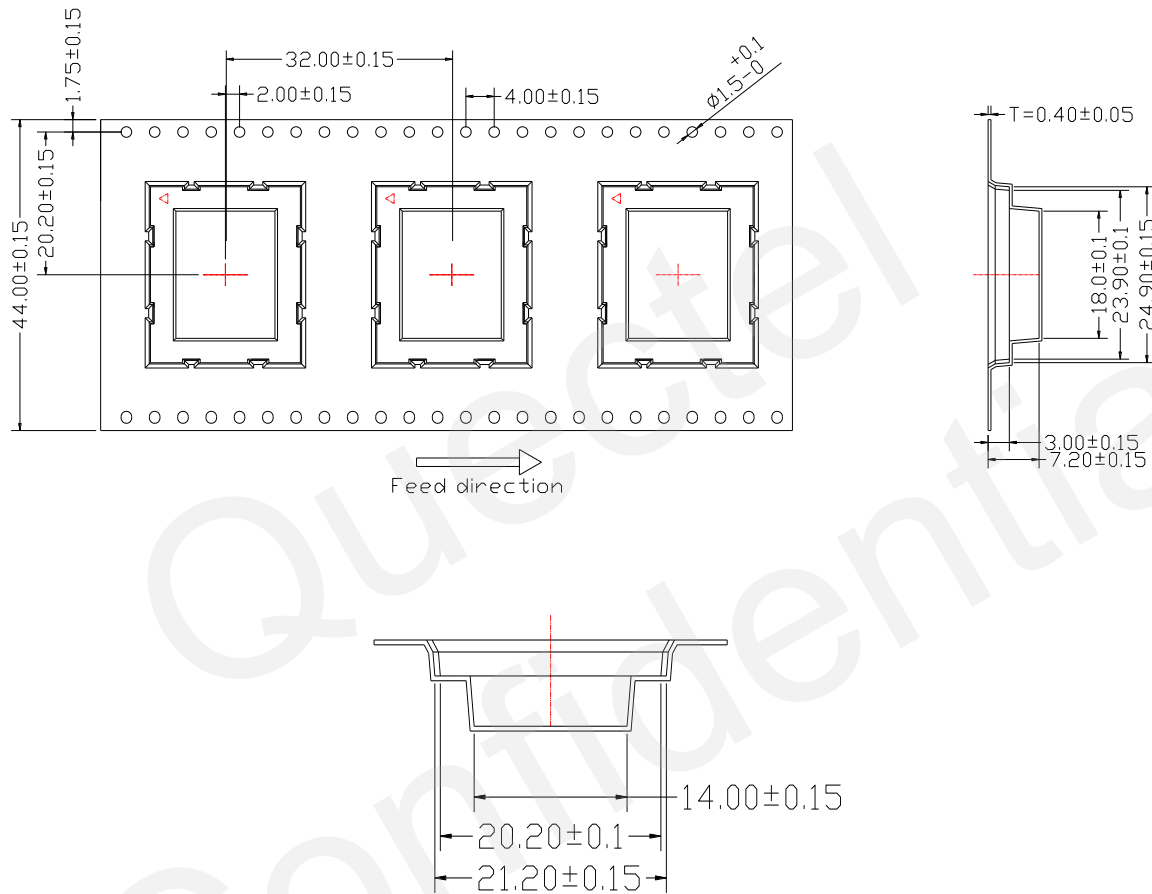

Figure 42: Tape and Reel Specification

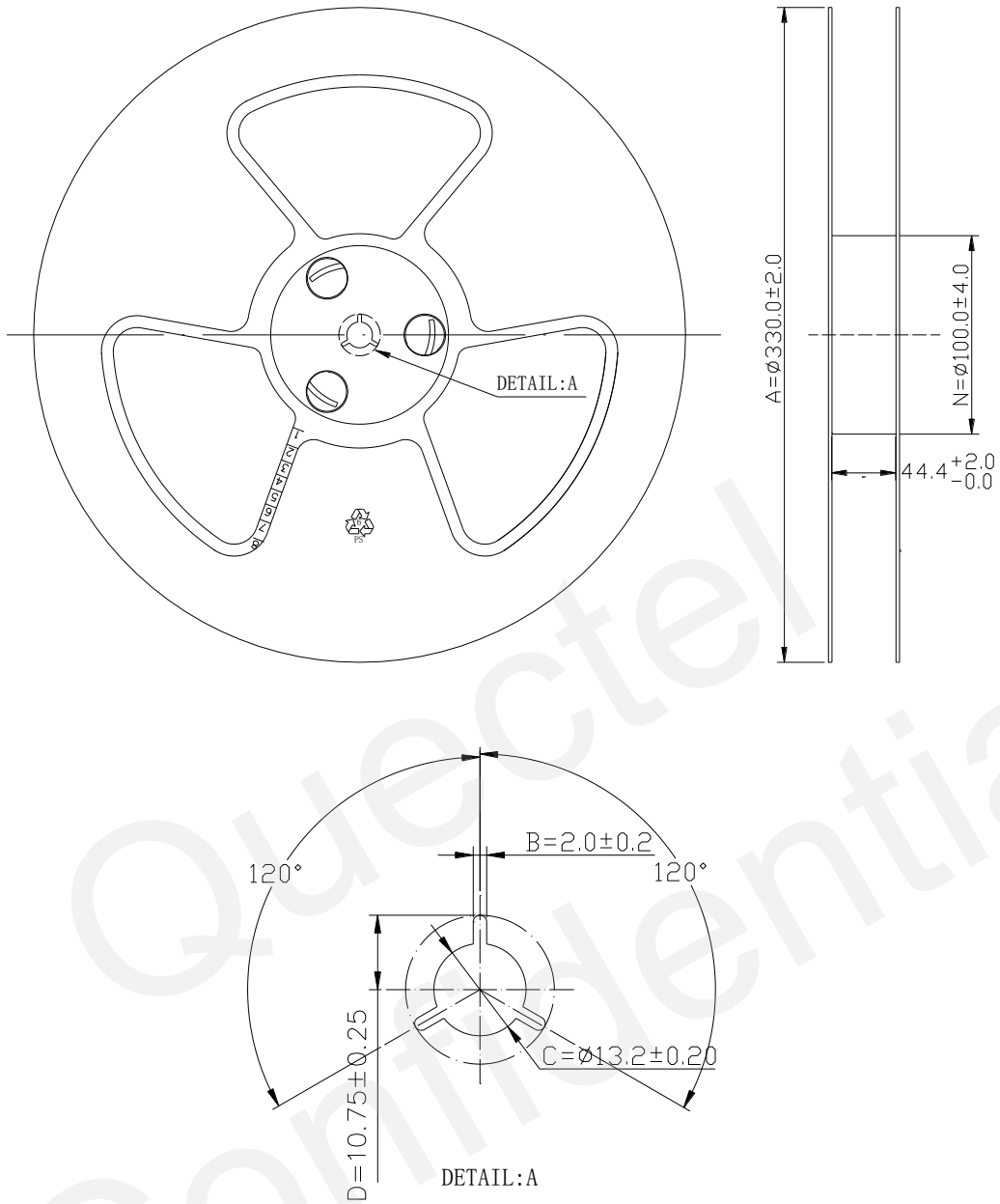

Figure 43: Dimensions of Reel

Table 28: Reel Packing

Model Name	MOQ for MP	Minimum Package: 250pcs	Minimum Package×4=1000pcs
UG95	250pcs	Size: 370 × 350 × 56mm ³ N.W: 0.63kg G.W: 1.41kg	Size: 380 × 250 × 365mm ³ N.W: 2.5kg G.W: 6.25kg

8 Appendix A Reference

Table 29: Related Documents

SN	Document Name	Remark
[1]	Quectel_WCDMA_UGxx_AT_Commands_Manual	UGxx AT Commands Manual
[2]	Quectel_UMTS<E_EVB_User_Guide	UMTS<E EVB User Guide
[3]	Quectel_UG95_Reference_Design	UG95 Reference Design
[4]	Quectel_UG95&M95 R2.0_Reference_Design	UG95 and M95 R2.0 Compatible Reference Design
[5]	Quectel_UG95&M95 R2.0_Compatible_Design	UG95 and M95 R2.0 Compatibility Design Specification
[6]	Quectel_Module_Secondary_SMT_User_Guide	Module Secondary SMT User Guide

Table 30: Terms and Abbreviations

Abbreviation	Description
AMR	Adaptive Multi-rate
ARP	Antenna Reference Point
bps	Bits Per Second
CHAP	Challenge Handshake Authentication Protocol
CS	Coding Scheme
CSD	Circuit Switched Data
CTS	Clear To Send
DRX	Discontinuous Reception
DCE	Data Communications Equipment (typically module)
DTE	Data Terminal Equipment (typically computer, external controller)

DTR	Data Terminal Ready
DTX	Discontinuous Transmission
EFR	Enhanced Full Rate
EGSM	Extended GSM900 band (includes standard GSM900 band)
ESD	Electrostatic Discharge
FR	Full Rate
GMSK	Gaussian Minimum Shift Keying
GPS	Global Positioning System
GSM	Global System for Mobile Communications
HR	Half Rate
HSPA	High Speed Packet Access
HSDPA	High Speed Downlink Packet Access
HSUPA	High Speed Uplink Packet Access
I2C	Inter-Integrated Circuit Interface
I/O	Input/Output
IMEI	International Mobile Equipment Identity
I _{max}	Maximum Load Current
I _{norm}	Normal Current
LED	Light Emitting Diode
LGA	Land Grid Array
LNA	Low Noise Amplifier
Mbps	Mbits per second
MO	Mobile Originated
MS	Mobile Station (GSM engine)
MT	Mobile Terminated

PAP	Password Authentication Protocol
PBCCH	Packet Broadcast Control Channel
PCB	Printed Circuit Board
PDU	Protocol Data Unit
PPP	Point-to-Point Protocol
PSK	Phase Shift Keying
PWM	Pulse Width Modulation
QAM	Quadrature Amplitude Modulation
QPSK	Quadrature Phase Shift Keying
RF	Radio Frequency
RHCP	Right Hand Circularly Polarized
RMS	Root Mean Square (value)
RTC	Real Time Clock
Rx	Receive
SIM	Subscriber Identification Module
SMS	Short Message Service
TDMA	Time Division Multiple Access
TE	Terminal Equipment
TX	Transmitting Direction
UART	Universal Asynchronous Receiver & Transmitter
UMTS	Universal Mobile Telecommunications System
URC	Unsolicited Result Code
USB	Universal Serial Bus
USIM	Universal Subscriber Identity Module
USSD	Unstructured Supplementary Service Data

V _{max}	Maximum Voltage Value
V _{norm}	Normal Voltage Value
V _{min}	Minimum Voltage Value
V _{IHmax}	Maximum Input High Level Voltage Value
V _{IHmin}	Minimum Input High Level Voltage Value
V _{ILmax}	Maximum Input Low Level Voltage Value
V _{ILmin}	Minimum Input Low Level Voltage Value
V _{Imax}	Absolute Maximum Input Voltage Value
V _{Imin}	Absolute Minimum Input Voltage Value
V _{OHmax}	Maximum Output High Level Voltage Value
V _{OHmin}	Minimum Output High Level Voltage Value
V _{OLmax}	Maximum Output Low Level Voltage Value
V _{OLmin}	Minimum Output Low Level Voltage Value
VSWR	Voltage Standing Wave Ratio
WCDMA	Wideband Code Division Multiple Access

9 Appendix B GPRS Coding Scheme

Table 31: Description of Different Coding Schemes

Scheme	CS-1	CS-2	CS-3	C4-4
Code Rate	1/2	2/3	3/4	1
USF	3	3	3	3
Pre-coded USF	3	6	6	12
Radio Block excl.USF and BCS	181	268	312	428
BCS	40	16	16	16
Tail	4	4	4	-
Coded Bits	456	588	676	456
Punctured Bits	0	132	220	-
Data Rate Kb/s	9.05	13.4	15.6	21.4

10 Appendix C GPRS Multi-slot Class

Twenty-nine classes of GPRS multi-slot modes are defined for MS in GPRS specification. Multi-slot classes are product dependant, and determine the maximum achievable data rates in both the uplink and downlink directions. Written as 3+1 or 2+2, the first number indicates the amount of downlink timeslots, while the second number indicates the amount of uplink timeslots. The active slots determine the total number of slots the GPRS device can use simultaneously for both uplink and downlink communications. The description of different multi-slot classes is shown in the following table.

Table 32: GPRS Multi-slot Classes

Multislot Class	Downlink Slots	Uplink Slots	Active Slots
1	1	1	2
2	2	1	3
3	2	2	3
4	3	1	4
5	2	2	4
6	3	2	4
7	3	3	4
8	4	1	5
9	3	2	5
10	4	2	5
11	4	3	5
12	4	4	5

11 Appendix D EDGE Modulation and Coding Scheme

Table 33: EDGE Modulation and Coding Scheme

Coding Scheme	Modulation	Coding Family	1 Timeslot	2 Timeslot	4 Timeslot
CS-1:	GMSK	/	9.05kbps	18.1kbps	36.2kbps
CS-2:	GMSK	/	13.4kbps	26.8kbps	53.6kbps
CS-3:	GMSK	/	15.6kbps	31.2kbps	62.4kbps
CS-4:	GMSK	/	21.4kbps	42.8kbps	85.6kbps
MCS-1	GMSK	C	8.80kbps	17.60kbps	35.20kbps
MCS-2	GMSK	B	11.2kbps	22.4kbps	44.8kbps
MCS-3	GMSK	A	14.8kbps	29.6kbps	59.2kbps
MCS-4	GMSK	C	17.6kbps	35.2kbps	70.4kbps
MCS-5	8-PSK	B	22.4kbps	44.8kbps	89.6kbps
MCS-6	8-PSK	A	29.6kbps	59.2kbps	118.4kbps
MCS-7	8-PSK	B	44.8kbps	89.6kbps	179.2kbps
MCS-8	8-PSK	A	54.4kbps	108.8kbps	217.6kbps
MCS-9	8-PSK	A	59.2kbps	118.4kbps	236.8kbps