



Product Overview

Thank you for purchasing the LaserLyte-Flex Green laser alignment system. It uses interchangeable optics and a green semiconductor laser diode to project a highly visible dot, line, cross, or a combined line and central dot. This helps you to accurately align and position garments, cloth, paper, wood, and metal of different shapes and surface profiles.

This guide explains how to mount and operate your laser, adjust the focus, and change projection optics. This guide also discusses the relationship between working distance, fan angle, and line length, and some applications of the LaserLyte-Flex Green.

If you have any queries or require help when using this product then please call is on +44 (0)1495 21213, email us at sales@globallasertech.com or contact your local representative.



Operating LaserLyte-Flex With 10V PS1/PS4 Power Supply

If you have purchased an extension lead:

1. Plug the male DC Jack end of the extension lead into the DC socket on the PS1/PS4
2. Plug the male DC Jack of the LaserLyte-Flex cable into the DC socket on the extension lead

If you have not purchased an extension lead:

3. Plug the male DC Jack of the LaserLyte-Flex cable directly into the DC socket on the PS1/PS4

If you are using more than one laser with the PS4 then repeat the above steps until all your lasers are connected.

4. Connect IEC plug to PS1/PS4
5. Plug the PS1/PS4 into a mains socket
6. Switch on PS1/PS4 with the optional key switch or at the mains socket

For further information please refer to the Universal Power Supplies datasheet.

Operating LaserLyte-Flex With 12V Battery Box

The battery box power supply provides power in applications where it is impractical to use a permanent power source.

1. Remove the lid of the box by unscrewing 4 x Phillips head screws
2. Insert 8 x industrial AAA batteries into battery compartment
3. Replace the lid
4. Plug the DC jack end of the LaserLyte-Flex cable into the DC socket on the battery box
5. Switch on the power supply using onboard rocker switch

For further information please refer to the Battery Box datasheet.

Focus Adjustment

The focus distance of your laser upon delivery will be set to 1000mm unless requested otherwise. This can be adjusted as follows:

1. Remove your interchangeable projection optic if one is fitted by unscrewing it from the main body of the laser module (see drawings A&B)
2. Insert the supplied focus key into the laser barrel and align with focus control grooves
3. Turn the focus key until your desired focus is achieved
4. Replace the interchangeable pattern optic by screwing it back onto the main body of the laser module

Changing Optics

A number of interchangeable projection optics are available as extra items for the LaserLyte-Flex. The base laser module, normally projecting a simple dot, can then be used to project patterns such as a cross, line, or a combined line & central dot.

To replace a projection optic:

1. Unscrew the projection optic from the main body of the laser module if one is currently fitted (see drawings A&B)
2. Replace the interchangeable pattern optic by screwing one back onto the main body of the laser module
3. Ensure that optics not fitted to the laser module are protected from dust or other contaminants

Mounting

The lifetime and stability of your laser can be optimised when mounted on a suitable heat sink. This allows the case temperature to be kept within its specified range. Failure to properly heat sink your laser device could result in shortened lifetime or failure of the diode. As a general guideline, the lifetime of a laser diode decreases by a factor of two (approx.) for every ten degree increase in operating temperature.

There are three mounting clamps available for the LaserLyte-Flex range: heavy duty clamp (with/without magnetic base), MK1 mounting kit, and swivel clamp.

Mounting the LaserLyte-Flex in the Heavy Duty Clamp (See Drawing C)

1. Secure the clamp to a surface. There are two methods:
 - a. Screw an M5 stud to the bottom of the base, or
 - b. Remove the base by removing 2 x grub screw B with the supplied Allen key, then thread an M5 cap screw through the top of the base. Then re-attach the base to the body of the clamp
2. Loosen Allen screw A with the supplied Allen key
3. Slide your laser into the mounting hole and then tighten Allen screw A
4. Loosen grub screw A
5. Adjust the vertical angle of your laser and then tighten grub screw A
6. Loosen 2 x grub screw B. This will allow the main body of the mount to be rotated independently of the base
7. Adjust the horizontal angle of your laser and then tighten 2 x grub screw B

Mounting the LaserLyte-Flex in the Heavy Duty Clamp with Magnetic Base (See Drawing C&E)

1. Secure the magnetic base to the Heavy Duty Clamp
 - a. Screw the stud on the top of the magnetic base into the centre hole at the bottom of the Heavy Duty Clamp
2. Remove the keeper from the magnetic base and place on a ferrous surface
3. Loosen Allen screw A with the supplied Allen key
4. Slide your laser into the mounting hole and then tighten Allen screw A
5. Loosen grub screw A
6. Adjust the vertical angle of your laser and then tighten grub screw A
7. Loosen 2 x grub screw B. This will allow the main body of the mount to be rotated independently of the base
8. Adjust the horizontal angle of your laser and then tighten 2 x grub screw B

Mounting the LaserLyte-Flex in the MK1 Mounting Kit (See Drawing D)

1. Attach components as in drawing D
2. Loosen machine screw A with M3 Allen key
3. Set the length of the mounting post
4. Secure the clamp to a surface using machine screw A (M5 x 25 & M5 x 35 machine screws)

two M5 hex nuts & washers are supplied)

5. Tighten machine screw A with an M3 Allen key
6. Loosen Phillips screw A with a Phillips head screwdriver
7. Slide the laser into the mounting hole
8. Rotate the mounting clamp to the desired position and then tighten Phillips screw A

Mounting the LaserLyte-Flex in the Swivel Mounting Clamp (See Drawing F)

1. Secure the mounting base to a surface
 - a. You can use 2 x Ø9 mm slots, 4 x Ø4.5 mm holes, and/or 2 x Ø3.5 mm countersunk holes to achieve this. If mounting via Ø3.5mm countersunk holes, the swivel bracket must be removed from the base and then reattached after mounting.
3. Loosen Allen screw A (M3)
4. Slide your laser into the mounting hole and then tighten Allen screw A
5. Loosen Allen screw B (M5)
6. Adjust tilt angle and then tighten Allen screw B
7. Loosen 2 x M4 screws attaching swivel bracket to base
8. Adjust swivel angle and then tighten 2 x M4 screws

Fan Angle & Working Distance

The length of a projected line increases with fan angle and working distance (WD). For example, a line with a fan angle of 60° will be longer than a line with a fan angle of 30° when viewed at a fixed working distance and at 90° to the surface. Given the WD and available fan angle, you can extract the expected line length from the below table.

		Line 33° <i>Homogeneous</i>	Line 60° <i>Homogeneous</i>	Line 90° <i>Homogeneous</i>	Line 105° <i>Homogeneous</i>	Cross 9° <i>DOE</i>	Cross 60° <i>Homogeneous</i>	Cross 100° <i>Homogeneous</i>	Long Line & Dot 100° <i>Gaussian</i>
Distance (mm)	250	148	289	500	652	39x39	289x289	596x596	596
	500	296	577	1000	1303	79x79	577x577	1192x1192	1192
	750	444	866	1500	1955	118x118	866x866	1788x1788	1788
	1000	592	1155	2000	2607	157x157	1155x1155	2384x2384	2384
	1250	741	1143	2500	3258	197x197	1443x1143	2979x2979	2979
	1500	889	1732	3000	3910	236x236	1732x1732	3575x3575	3575
	1750	1037	2021	3500	4561	275x275	2021x2021	4171x4171	4171
	2000	1185	2309	4000	53213	315x315	2309x2039	4767x4767	4767
	2250	1333	2598	4500	5865	354x354	2598x2598	5363x5363	5363
	2500	1481	2887	5000	6516	394x394	2887x2887	5959x5959	5959
	2750	1629	3175	5500	7168	433x433	3175x3175	6555x6555	6555
	3000	1777	3464	6000	7819	472x472	3464x3646	7151x7151	7151

Line Length (mm)

Applications

The LaserLyte-Flex Green is suitable for many different applications, some of which are below. If you would like further information then please contact your local distributor or Global Laser.

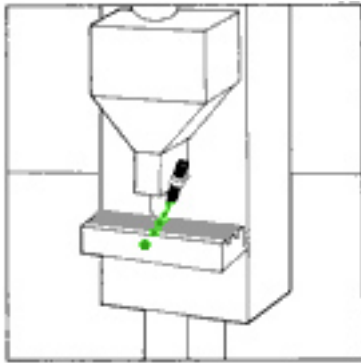

Machine Alignment

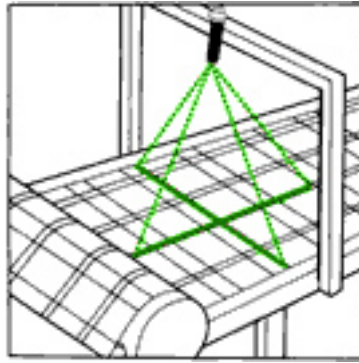

Pattern Alignment

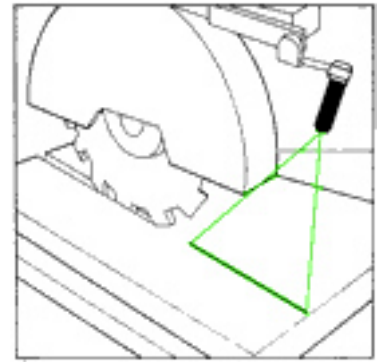

Saw & Cutting Guidance

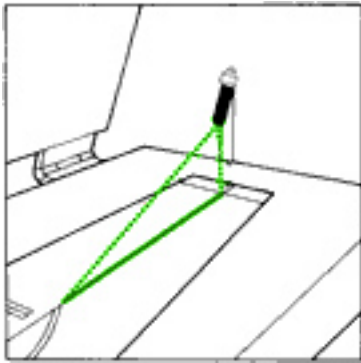

Positioning

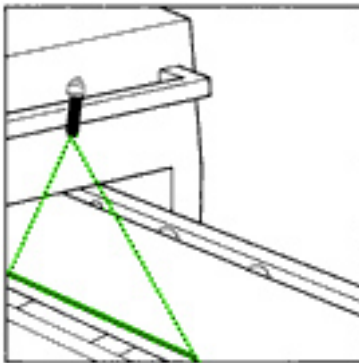

Edge Alignment

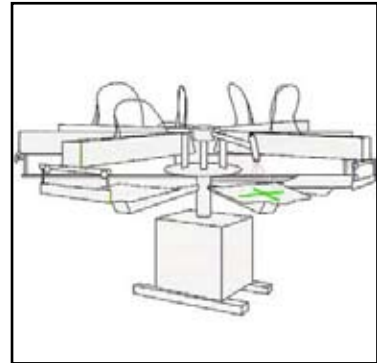

Screen Printing

Warranty & Repair

The LaserLyte-Flex Green is supplied with a 12 month parts and labour warranty. Our manufacturing operations are certified to ISO9001.

If your product develops a fault within 12 months from the date of purchase Global Laser will repair/replace your product. If you wish to return a faulty product then please contact your local representative or Global Laser to obtain a RMA code (Return Material Authorisation). Then package your product carefully, including a note of your RMA code, and return to the address below:

Global Laser Ltd
Units 9-10
Roseheyworth Business Park
Abertillery
Gwent, NP13 1SP
United Kingdom

Safety & Classification

These modules are intended for incorporation into customer equipment. They are classified in accordance with IEC60825-1 2007, which should be consulted prior to designing or using any laser product. The following labels are supplied for attachment to the customer's equipment, but responsibility for compliance with the standard remains with the user.

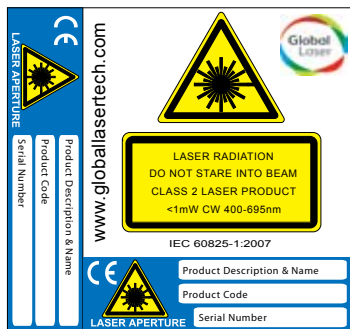

Class 2 Laser Label

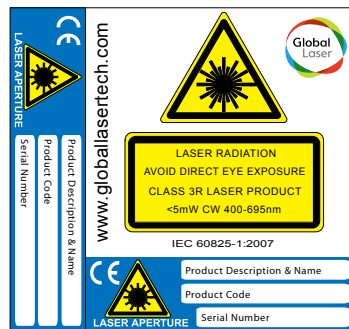

Class 3R Laser Label

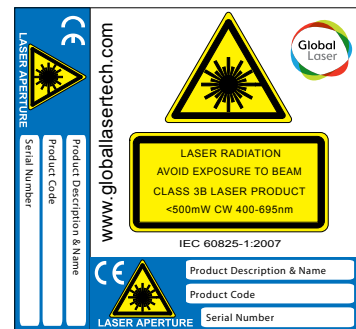

Class 3B Laser Label

Diagrams

A) LaserLyte-Flex

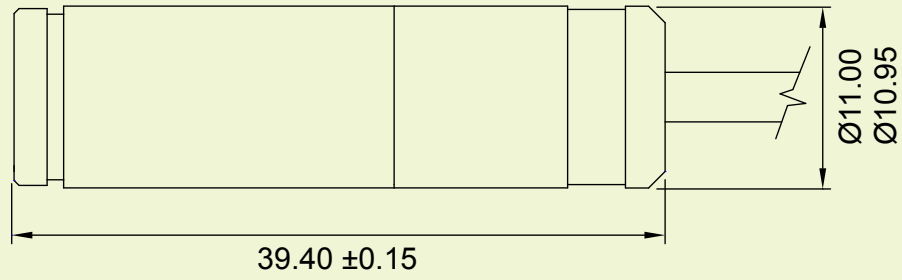

B) LaserLyte-Flex with Line/Cross Optics Fitted

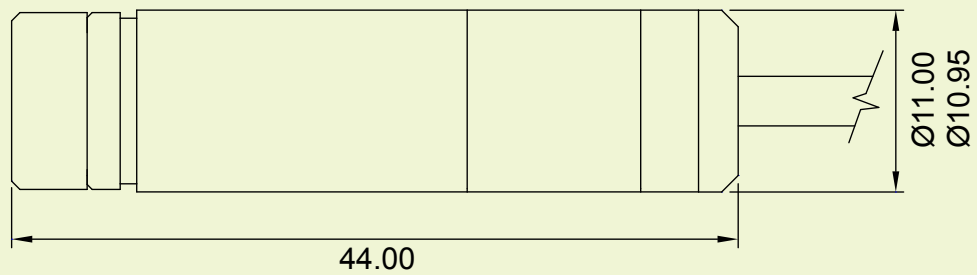

C) Heavy Duty Mounting Clamp

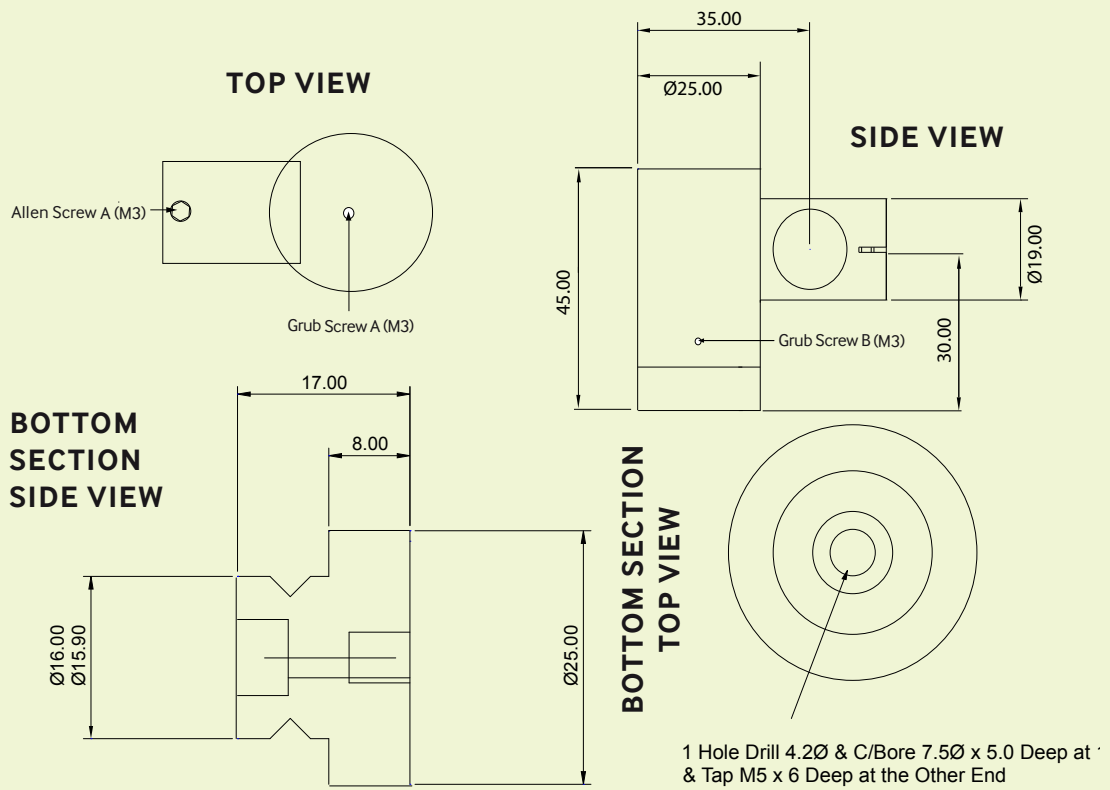

D) MK1 Mounting Clamp

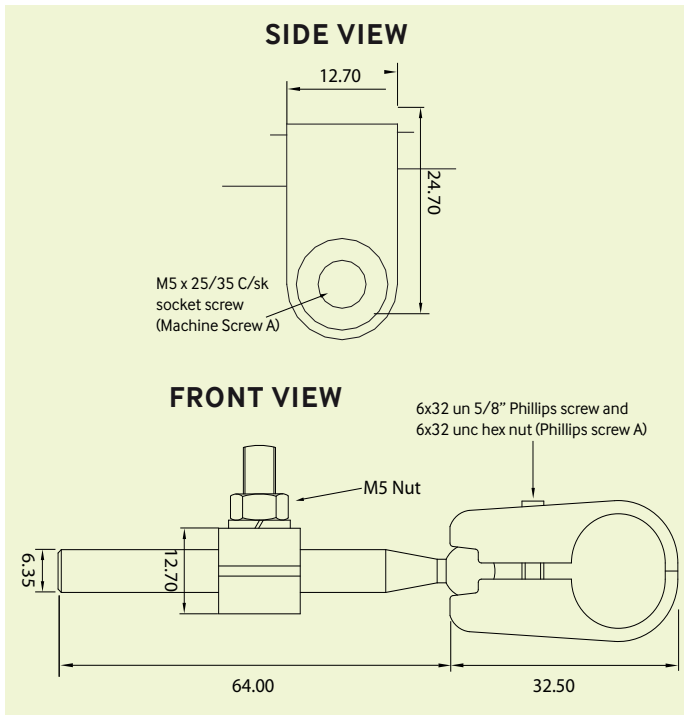

E) Magnetic Base

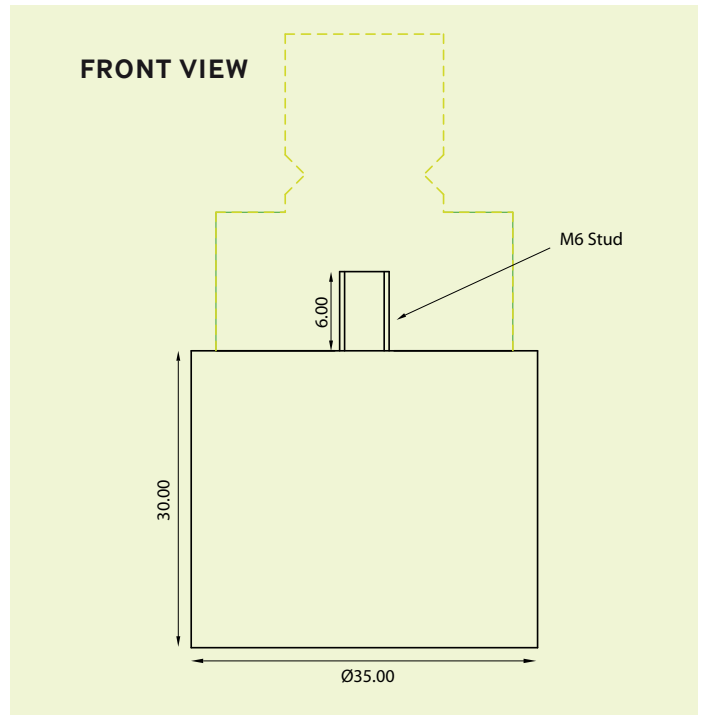

F) Swivel Mounting Clamp

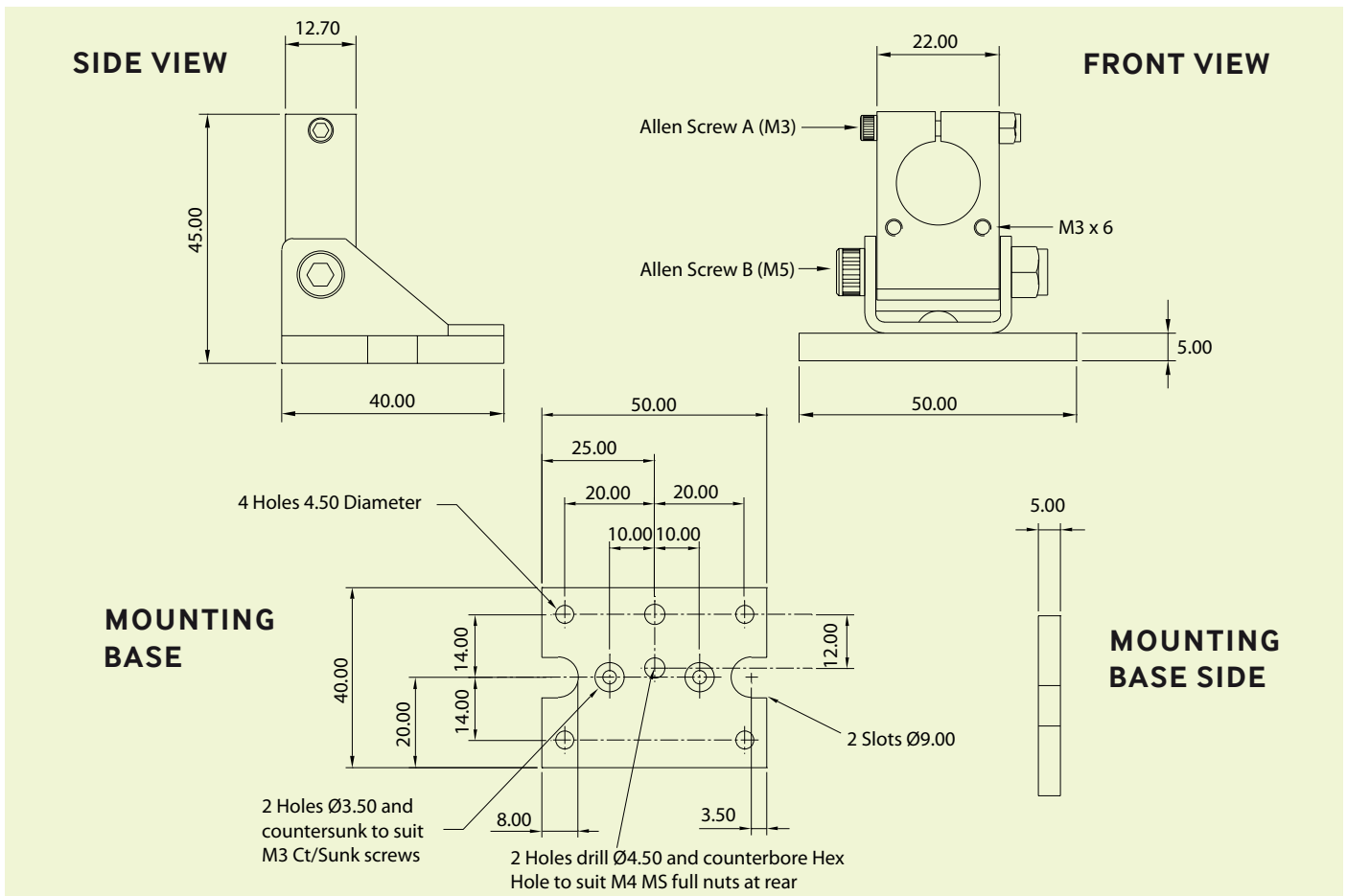

Please Note: Global Laser reserve the right to change descriptions and specifications without notice.

T: +44 (0)1495 212213
 F: +44 (0)1495 214004
 E: sales@globallasertech.com
 www.globallasertech.com

Global Laser Ltd
 Units 9-10
 Roseheyworth Business Park
 Abertillery, Gwent NP13 1SP UK