



Microprocessor Supervisory Circuits

General Description

The MAX691A/MAX693A/MAX800L/MAX800M microprocessor (μ P) supervisory circuits are pin-compatible upgrades to the MAX691, MAX693, and MAX695. They improve performance with 30 μ A supply current, 200ms typ reset active delay on power-up, and 6ns chip-enable propagation delay. Features include write protection of CMOS RAM or EEPROM, separate watchdog outputs, backup-battery switchover, and a $\overline{\text{RESET}}$ output that is valid with V_{CC} down to 1V. The MAX691A/MAX800L have a 4.65V typical reset-threshold voltage, and the MAX693A/MAX800Ms' reset threshold is 4.4V typical. The MAX800L/MAX800M guarantee power-fail accuracies to $\pm 2\%$.

Applications

- Computers
- Controllers
- Intelligent Instruments
- Automotive Systems
- Critical μ P Power Monitoring

Typical Operating Circuit

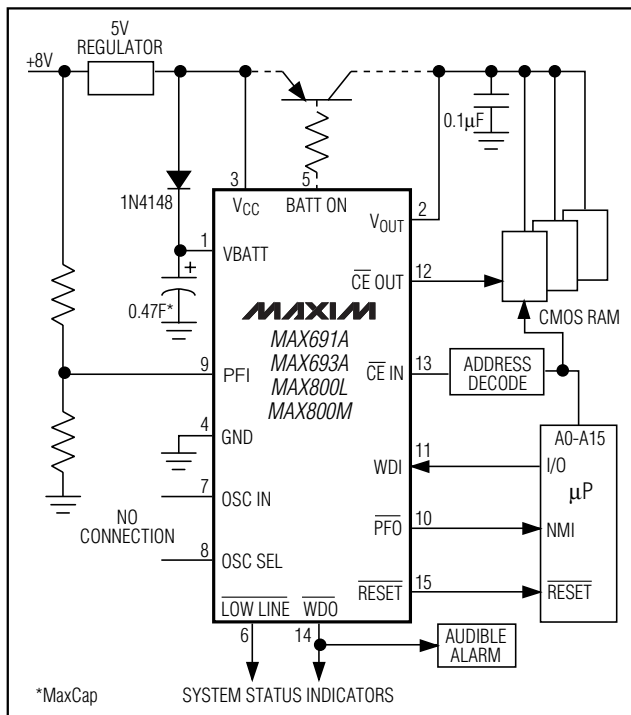

SuperCap is a registered trademark of Baknor Industries. MaxCap is a registered trademark of The Carborundum Corp.

Features

- ◆ 200ms Power-OK/Reset Timeout Period
- ◆ 1 μ A Standby Current, 30 μ A Operating Current
- ◆ On-Board Gating of Chip-Enable Signals, 10ns max Delay
- ◆ MaxCap™ or SuperCap™ Compatible
- ◆ Guaranteed $\overline{\text{RESET}}$ Assertion to $V_{\text{CC}} = +1\text{V}$
- ◆ Voltage Monitor for Power-Fail or Low-Battery Warning
- ◆ Power-Fail Accuracy Guaranteed to $\pm 2\%$ (MAX800L/M)
- ◆ Available in 16-Pin Narrow SO, Plastic DIP, and TSSOP Packages

Ordering Information

PART	TEMP. RANGE	PIN-PACKAGE
MAX691ACUE	0°C to +70°C	16 TSSOP
MAX691ACSE	0°C to +70°C	16 Narrow SO
MAX691ACWE	0°C to +70°C	16 Wide SO
MAX691ACPE	0°C to +70°C	16 Plastic DIP
MAX691AC/D	0°C to +70°C	Dice*
MAX691AEUE	-40°C to +85°C	16 TSSOP
MAX691AESE	-40°C to +85°C	16 Narrow SO
MAX691AEWE	-40°C to +85°C	16 Wide SO
MAX691AEPE	-40°C to +85°C	16 Plastic DIP
MAX691AEJE	-40°C to +85°C	16 CERDIP
MAX691AMJE	-55°C to +125°C	16 CERDIP

Ordering Information continued on last page.

*Dice are specified at $T_A = +25^\circ\text{C}$, DC parameters only.

Pin Configuration

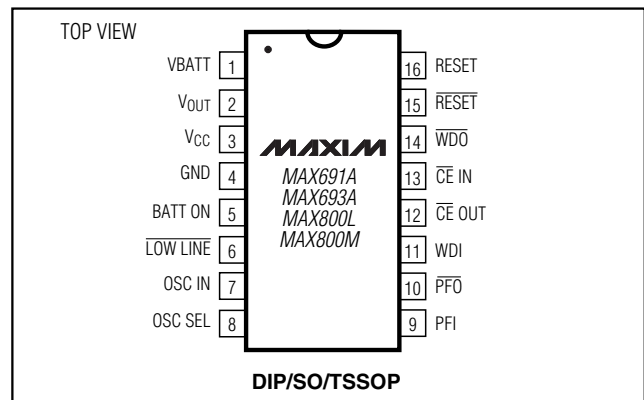

MAX691A/MAX693A/MAX800L/MAX800M



Microprocessor Supervisory Circuits

ABSOLUTE MAXIMUM RATINGS

Terminal Voltage (with respect to GND)

V _{CC}	-0.3V to +6V
VBATT	-0.3V to +6V
All Other Inputs	-0.3V to (V _{OUT} + 0.3V)

Input Current

V _{CC} Peak	1.0A
V _{CC} Continuous	250mA
VBATT Peak	250mA
VBATT Continuous	25mA
GND, BATT ON	100mA
All Other Outputs	25mA

Continuous Power Dissipation (T_A = +70°C)

TSSOP (derate 6.70mW/°C above +70°C)	533mW
Narrow SO (derate 8.70mW/°C above +70°C)	696mW
Wide SO (derate 9.52mW/°C above +70°C)	762mW
Plastic DIP (derate 10.53mW/°C above +70°C)	842mW
CERDIP (derate 10.00mW/°C above +70°C)	800mW

Operating Temperature Ranges

MAX69_AC_/MAX800_C_	0°C to +70°C
MAX69_AE_/MAX800_E_	-40°C to +85°C
MAX69_AMJE	-55°C to +125°C

Storage Temperature Range

Lead Temperature (soldering, 10s)

Stresses beyond those listed under "Absolute Maximum Ratings" may cause permanent damage to the device. These are stress ratings only, and functional operation of the device at these or any other conditions beyond those indicated in the operational sections of the specifications is not implied. Exposure to absolute maximum rating conditions for extended periods may affect device reliability.

ELECTRICAL CHARACTERISTICS

(MAX691A, MAX800L: V_{CC} = +4.75V to +5.5V; MAX693A, MAX800M: V_{CC} = +4.5V to +5.5V; VBATT = 2.8V, T_A = T_{MIN} to T_{MAX}, unless otherwise noted.)

PARAMETER	CONDITIONS		MIN	TYP	MAX	UNITS
Operating Voltage Range, V _{CC} , VBATT (Note 1)			0		5.5	V
V _{OUT} Output	V _{CC} = 4.5V	I _{OUT} = 25mA		V _{CC} - 0.02	V _{CC} - 0.05	V
		I _{OUT} = 250mA	MAX69_AC	V _{CC} - 0.2	V _{CC} - 0.3	
			MAX69_AE, MAX800_C/E	V _{CC} - 0.2	V _{CC} - 0.35	
			MAX69_A/M		V _{CC} - 0.40	
I _{OUT} = 210mA	MAX69_AC/AE, MAX800_C/E	V _{CC} - 0.17	V _{CC} - 0.3V			
V _{CC} -to-V _{OUT} On-Resistance	V _{CC} = 4.5V	MAX69_AC, MAX800_C		0.8	1.2	Ω
		MAX69_AE, MAX800_E		0.8	1.4	
		MAX69_A/M		0.8	1.6	
V _{OUT} in Battery-Backup Mode	VBATT = 4.5V, I _{OUT} = 20mA		VBATT - 0.3		V	
	VBATT = 2.8V, I _{OUT} = 10mA		VBATT - 0.25			
	VBATT = 2.0V, I _{OUT} = 5mA		VBATT - 0.15			
VBATT-to-V _{OUT} On-Resistance	VBATT = 4.5V				15	Ω
	VBATT = 2.8V				25	
	VBATT = 2.0V				30	
Supply Current in Normal Operating Mode (excludes I _{OUT})	V _{CC} > VBATT - 1V			30	100	μA
Supply Current in Battery-Backup Mode (excludes I _{OUT}) (Note 2)	V _{CC} < VBATT - 1.2V, VBATT = 2.8V	T _A = +25°C		0.04	1	μA
		T _A = T _{MIN} + T _{MIN}			5	
VBATT Standby Current (Note 3)	VBATT + 0.2V ≤ V _{CC}	T _A = +25°C	-0.1		0.02	μA
		T _A = T _{MIN} + T _{MIN}	-1.0		0.02	
Battery Switchover Threshold	Power-up				VBATT + 0.3	V
	Power-down				VBATT - 0.3	

Microprocessor Supervisory Circuits

ELECTRICAL CHARACTERISTICS (continued)

(MAX691A, MAX800L: $V_{CC} = +4.75V$ to $+5.5V$; MAX693A, MAX800M: $V_{CC} = +4.5V$ to $+5.5V$; $V_{BATT} = 2.8V$, $T_A = T_{MIN}$ to T_{MAX} , unless otherwise noted.)

PARAMETER	CONDITIONS	MIN	TYP	MAX	UNITS
Battery Switchover Hysteresis			60		mV
BATT ON Output Low Voltage	$I_{SINK} = 3.2mA$		0.1	0.4	V
	$I_{SINK} = 25mA$		0.7	1.5	
BATT ON Output Short-Circuit Current	Sink current		60		mA
	Source current	1	15	100	μA
RESET AND WATCHDOG TIMER					
Reset Threshold Voltage	MAX691A, MAX800L	4.50	4.65	4.75	V
	MAX693A, MAX800M	4.25	4.40	4.50	
	MAX800L, $T_A = +25^\circ C$, V_{CC} falling	4.55		4.70	
	MAX800M, $T_A = +25^\circ C$, V_{CC} falling	4.30		4.45	
Reset Threshold Hysteresis			15		mV
V_{CC} to RESET Delay	Power-down		80		μs
$\overline{LOW\ LINE}$ -to-RESET Delay			800		ns
Reset Active Timeout Period, Internal Oscillator	Power-up	140	200	280	ms
Reset Active Timeout Period, External Clock (Note 4)	Power-up		2048		Clock Cycles
Watchdog Timeout Period, Internal Oscillator	Long period	1.0	1.6	2.25	sec
	Short period	70	100	140	ms
Watchdog Timeout Period, External Clock (Note 4)	Long period		4096		Clock Cycles
	Short period		1024		
Minimum Watchdog Input Pulse Width	$V_{IL} = 0.8V$, $V_{IH} = 0.75 \times V_{CC}$	100			ns
\overline{RESET} Output Voltage	$I_{SINK} = 50\mu A$, $V_{CC} = 1V$, $V_{BATT} = 0V$, V_{CC} falling		0.004	0.3	V
	$I_{SINK} = 3.2mA$, $V_{CC} = 4.25V$		0.1	0.4	
	$I_{SOURCE} = 1.6mA$, $V_{CC} = 5V$	3.5			
\overline{RESET} Output Short-Circuit Current	Output source current		7	20	mA
RESET Output Voltage Low (Note 5)	$I_{SINK} = 3.2mA$	0.1	0.4		V
$\overline{LOW\ LINE}$ Output Voltage	$I_{SINK} = 3.2mA$, $V_{CC} = 4.25V$			0.4	V
	$I_{SOURCE} = 1\mu A$, $V_{CC} = 5V$	3.5			
$\overline{LOW\ LINE}$ Output Short-Circuit Current	Output source current	1	15	100	μA
\overline{WDO} Output Voltage	$I_{SINK} = 3.2mA$			0.4	V
	$I_{SOURCE} = 500\mu A$, $V_{CC} = 5V$	3.5			
\overline{WDO} Output Short-Circuit Current	Output source current		3	10	mA
WDI Threshold Voltage (Note 6)	V_{IH}	$0.75 \times V_{CC}$			V
	V_{IL}			0.8	
WDI Input Current	WDI = 0V	-50	-10		μA
	WDI = V_{OUT}		20	50	

MAX691A/MAX693A/MAX800L/MAX800M

Microprocessor Supervisory Circuits

MAX691A/MAX693A/MAX800L/MAX800M

ELECTRICAL CHARACTERISTICS (continued)

(MAX691A, MAX800L: $V_{CC} = +4.75V$ to $+5.5V$; MAX693A, MAX800M: $V_{CC} = +4.5V$ to $+5.5V$; $V_{BATT} = 2.8V$, $T_A = T_{MIN}$ to T_{MAX} , unless otherwise noted.)

PARAMETER	CONDITIONS	MIN	TYP	MAX	UNITS
POWER-FAIL COMPARATOR					
PFI Input Threshold	MAX69_AC/AE/AM, $V_{CC} = 5V$	1.2	1.25	1.3	V
	MAX800_C/E, $V_{CC} = 5V$	1.225	1.25	1.275	
PFI Leakage Current			± 0.01	± 25	nA
\overline{PFO} Output Voltage	$I_{SINK} = 3.2mA$			0.4	V
	$I_{SOURCE} = 1\mu A$, $V_{CC} = 5V$	3.5			
\overline{PFO} Output Short-Circuit Current	Output source current	1	15	100	μA
PFI-to-PFO Delay	$V_{IN} = -20mV$, $V_{OD} = 15mV$		25		μs
	$V_{IN} = 20mV$, $V_{OD} = 15mV$		60		
CHIP-ENABLE GATING					
\overline{CE} IN Leakage Current	Disable mode		± 0.005	± 1	μA
\overline{CE} IN-to- \overline{CE} OUT Resistance (Note 7)	Enable mode		75	150	Ω
\overline{CE} OUT Short-Circuit Current (Reset Active)	Disable mode, \overline{CE} OUT = 0V	0.1	0.75	2.0	mA
\overline{CE} IN-to- \overline{CE} OUT Propagation Delay (Note 8)	50 Ω source impedance driver, $C_{LOAD} = 50pF$		6	10	ns
\overline{CE} OUT Output Voltage High (Reset Active)	$V_{CC} = 5V$, $I_{OUT} = -100\mu A$	3.5			V
	$V_{CC} = 0V$, $V_{BATT} = 2.8V$, $I_{OUT} = 1\mu A$	2.7			
RESET-to- \overline{CE} OUT Delay	Power-down		12		μs
INTERNAL OSCILLATOR					
OSC IN Leakage Current	OSC SEL = 0V		0.10	± 5	μA
OSC IN Input Pull-Up Current	OSC SEL = V_{OUT} or floating, OSC IN = 0V		10	100	μA
OSC SEL Input Pull-Up Current	OSC SEL = 0V		10	100	μA
OSC IN Frequency Range	OSC SEL = 0V		50		kHz
OSC IN External Oscillator Threshold Voltage	V_{IH}	$V_{OUT} - 0.3$	$V_{OUT} - 0.6$		V
	V_{IL}		3.65	2.00	
OSC IN Frequency with External Capacitor	OSC SEL = 0V, $C_{OSC} = 47pF$		100		kHz

Note 1: Either V_{CC} or V_{BATT} can go to 0V, if the other is greater than 2.0V.

Note 2: The supply current drawn by the MAX691A/MAX800L/MAX800M from the battery excluding I_{OUT} typically goes to 10 μA when $(V_{BATT} - 1V) < V_{CC} < V_{BATT}$. In most applications, this is a brief period as V_{CC} falls through this region.

Note 3: "+" = battery-discharging current, "-" = battery-charging current.

Note 4: Although presented as typical values, the number of clock cycles for the reset and watchdog timeout periods are fixed and do not vary with process or temperature.

Note 5: RESET is an open-drain output and sinks current only.

Note 6: WDI is internally connected to a voltage divider between V_{OUT} and GND. If unconnected, WDI is driven to 1.6V (typ), disabling the watchdog function.

Note 7: The chip-enable resistance is tested with $V_{CC} = +4.75V$ for the MAX691A/MAX800L and $V_{CC} = +4.5V$ for the MAX693A/MAX800M. \overline{CE} IN = \overline{CE} OUT = $V_{CC} / 2$.

Note 8: The chip-enable propagation delay is measured from the 50% point at \overline{CE} IN to the 50% point at \overline{CE} OUT.

Microprocessor Supervisory Circuits

Typical Operating Characteristics

($T_A = +25^\circ\text{C}$, unless otherwise noted.)

MAX691A/MAX693A/MAX800L/MAX800M

V_{CC} SUPPLY CURRENT vs. TEMPERATURE (NORMAL OPERATING MODE)

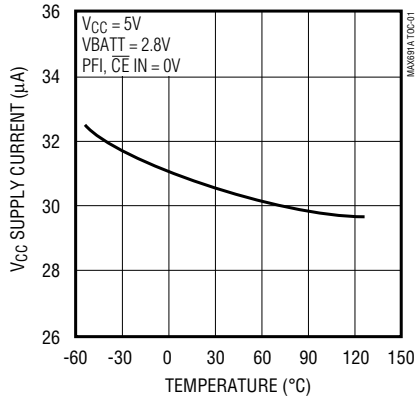

BATTERY SUPPLY CURRENT vs. TEMPERATURE (BATTERY-BACKUP MODE)

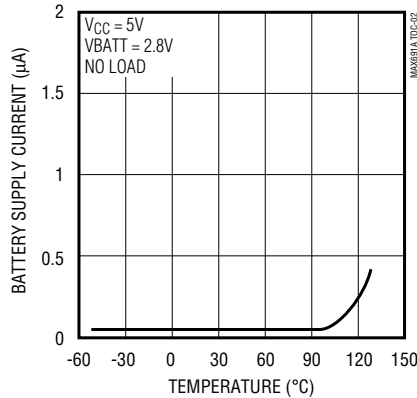

CHIP-ENABLE ON-RESISTANCE vs. TEMPERATURE

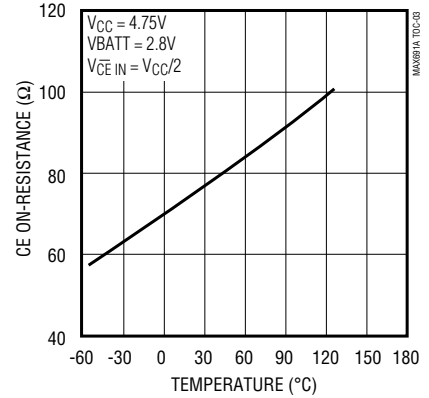

V_{BATT} to V_{OUT} ON-RESISTANCE vs. TEMPERATURE

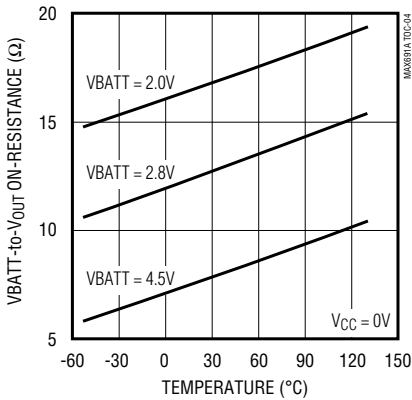

V_{CC} to V_{OUT} ON-RESISTANCE vs. TEMPERATURE

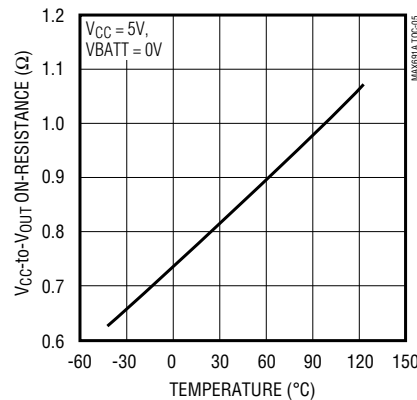

PFI THRESHOLD vs. TEMPERATURE

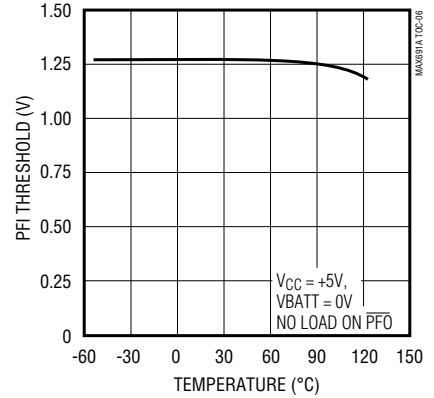

RESET THRESHOLD vs. TEMPERATURE

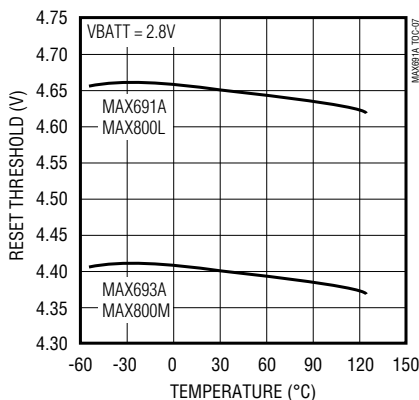

RESET OUTPUT RESISTANCE vs. TEMPERATURE

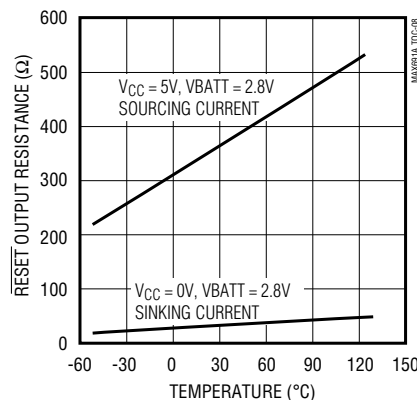

RESET DELAY vs. TEMPERATURE

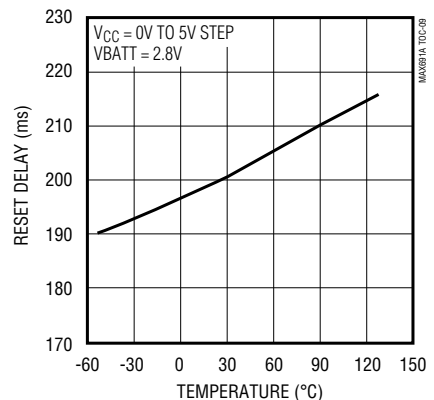

Microprocessor Supervisory Circuits

Typical Operating Characteristics (continued)

($T_A = +25^\circ\text{C}$, unless otherwise noted.)

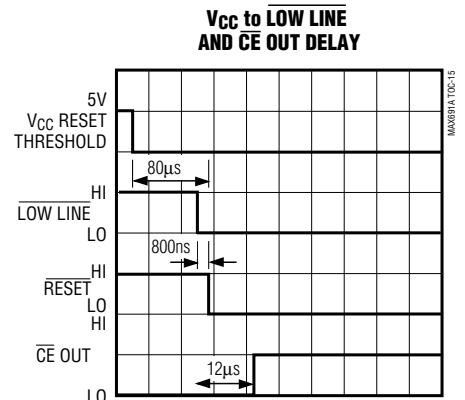
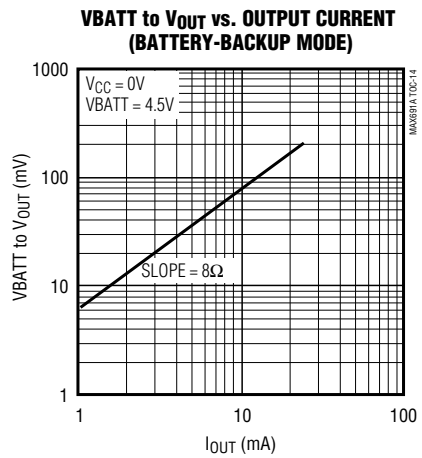
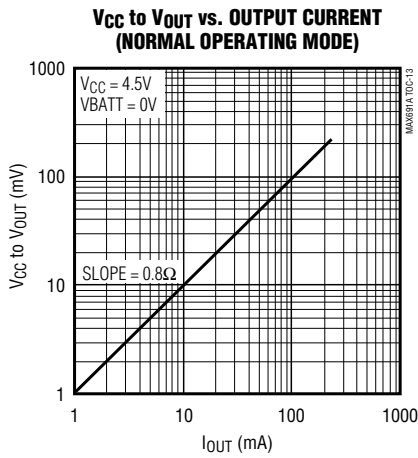
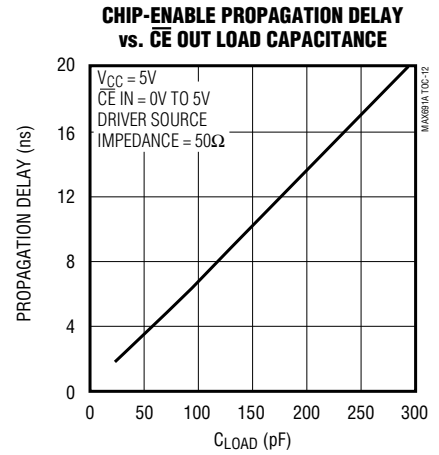
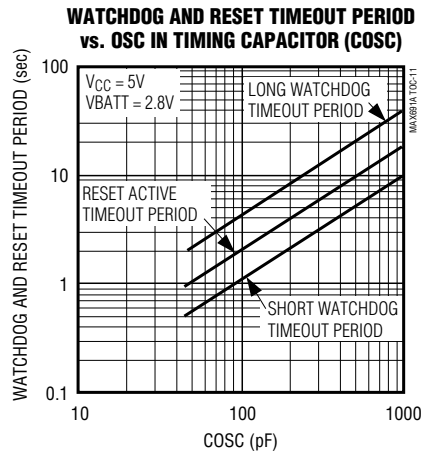
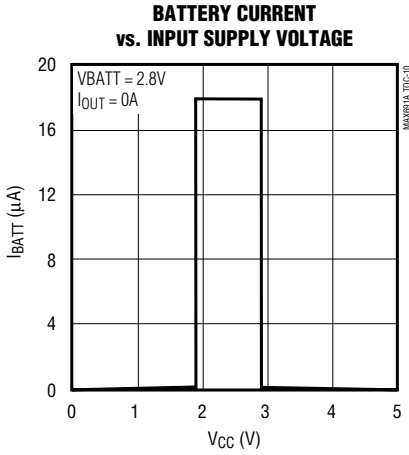

Microprocessor Supervisory Circuits

Pin Description

PIN	NAME	FUNCTION
1	VBATT	Battery-Backup Input. Connect to external battery or capacitor and charging circuit. If backup battery is not used, connect to GND.
2	V _{OUT}	Output Supply Voltage. When V _{CC} is greater than VBATT and above the reset threshold, V _{OUT} connects to V _{CC} . When V _{CC} falls below VBATT and is below the reset threshold, V _{OUT} connects to VBATT. Connect a 0.1µF capacitor from V _{OUT} to GND. Connect V _{OUT} to V _{CC} if no backup battery is used.
3	V _{CC}	Input Supply Voltage, 5V input.
4	GND	Ground. 0V reference for all signals.
5	BATT ON	Battery On Output. When V _{OUT} switches to VBATT, BATT ON goes high. When V _{OUT} switches to V _{CC} , BATT ON goes low. Connect the base of a PNP through a current-limiting resistor to BATT ON for V _{OUT} current requirements greater than 250mA.
6	$\overline{\text{LOW LINE}}$	$\overline{\text{LOW LINE}}$ output goes low when V _{CC} falls below the reset threshold. It returns high as soon as V _{CC} rises above the reset threshold.
7	OSC IN	External Oscillator Input. When OSC SEL is unconnected or driven high, a 10µA pull-up connects from V _{OUT} to OSC IN, the internal oscillator sets the reset and watchdog timeout periods, and OSC IN selects between fast and slow watchdog timeout periods. When OSC SEL is driven low, the reset and watchdog timeout periods may be set either by a capacitor from OSC IN to ground or by an external clock at OSC IN (Figure 3).
8	OSC SEL	Oscillator Select. When OSC SEL is unconnected or driven high, the internal oscillator sets the reset delay and watchdog timeout period. When OSC SEL is low, the external oscillator input (OSC IN) is enabled (Table 1). OSC SEL has a 10µA internal pull-up.
9	PFI	Power-Fail Input. This is the noninverting input to the power-fail comparator. When PFI is less than 1.25V, $\overline{\text{PFO}}$ goes low. When PFI is not used, connect PFI to GND or V _{OUT} .
10	$\overline{\text{PFO}}$	Power-Fail Output. This is the output of the power-fail comparator. $\overline{\text{PFO}}$ goes low when PFI is less than 1.25V. This is an uncommitted comparator, and has no effect on any other internal circuitry.
11	WDI	Watchdog Input. WDI is a three-level input. If WDI remains either high or low for longer than the watchdog timeout period, $\overline{\text{WDO}}$ goes low and reset is asserted for the reset timeout period. $\overline{\text{WDO}}$ remains low until the next transition at WDI. Leaving WDI unconnected disables the watchdog function. WDI connects to an internal voltage divider between V _{OUT} and GND, which sets it to mid-supply when left unconnected.
12	$\overline{\text{CE OUT}}$	Chip-Enable Output. $\overline{\text{CE OUT}}$ goes low only when $\overline{\text{CE IN}}$ is low and V _{CC} is above the reset threshold. If CE IN is low when reset is asserted, $\overline{\text{CE OUT}}$ will stay low for 15µs or until $\overline{\text{CE IN}}$ goes high, whichever occurs first.
13	$\overline{\text{CE IN}}$	Chip-Enable Input. The input to chip-enable gating circuit. If $\overline{\text{CE IN}}$ is not used, connect $\overline{\text{CE IN}}$ to GND or V _{OUT} .
14	$\overline{\text{WDO}}$	Watchdog Output. If WDI remains high or low longer than the watchdog timeout period, $\overline{\text{WDO}}$ goes low and reset is asserted for the reset timeout period. $\overline{\text{WDO}}$ returns high on the next transition at WDI. $\overline{\text{WDO}}$ remains high if WDI is unconnected.
15	$\overline{\text{RESET}}$	$\overline{\text{RESET}}$ Output goes low whenever V _{CC} falls below the reset threshold. $\overline{\text{RESET}}$ will remain low typically for 200ms after V _{CC} crosses the reset threshold on power-up.
16	RESET	RESET is an active-high output. It is open drain, and the inverse of $\overline{\text{RESET}}$.

Detailed Description

$\overline{\text{RESET}}$ and RESET Outputs

The MAX691A/MAX693A/MAX800L/MAX800M's $\overline{\text{RESET}}$ and RESET outputs ensure that the µP (with reset inputs asserted either high or low) powers up in a known state, and prevents code-execution errors during power-down or brownout conditions.

The $\overline{\text{RESET}}$ output is active low, and typically sinks 3.2mA at 0.1V saturation voltage in its active state. When deasserted, $\overline{\text{RESET}}$ sources 1.6mA at typically V_{OUT} - 0.5V. RESET output is open drain, active high, and typically sinks 3.2mA with a saturation voltage of 0.1V. When no backup battery is used, $\overline{\text{RESET}}$ output is

guaranteed to be valid down to V_{CC} = 1V, and an external 10kΩ pull-down resistor on $\overline{\text{RESET}}$ insures that it will be valid with V_{CC} down to GND (Figure 1). As V_{CC} goes below 1V, the gate drive to the RESET output switch reduces accordingly, increasing the R_{DS(ON)} and the saturation voltage. The 10kΩ pull-down resistor insures the parallel combination of switch plus resistor is around 10kΩ and the output saturation voltage is below 0.4V while sinking 40µA. When using a 10kΩ external pull-down resistor, the high state for $\overline{\text{RESET}}$ output with V_{CC} = 4.75V will be 4.5V typical. For battery voltages ≥ 2V connected to VBATT, $\overline{\text{RESET}}$ and RESET remain valid for V_{CC} from 0V to 5.5V.

MAX691A/MAX693A/MAX800L/MAX800M

Microprocessor Supervisory Circuits

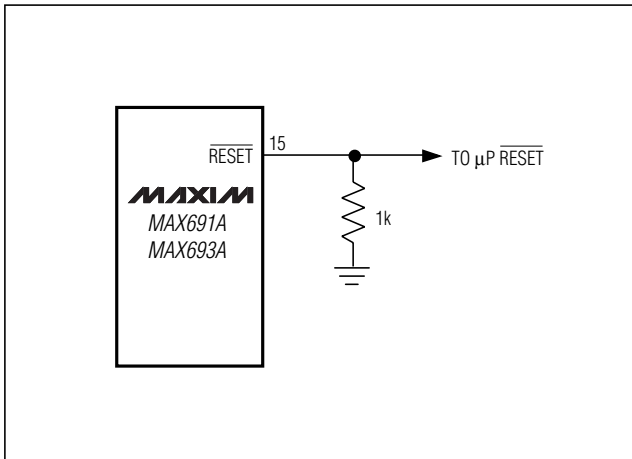

Figure 1. Adding an external pull-down resistor ensures $\overline{\text{RESET}}$ is valid with V_{CC} down to GND.

$\overline{\text{RESET}}$ and $\overline{\text{RESET}}$ are asserted when V_{CC} falls below the reset threshold (4.65V for the MAX691A/MAX800L, 4.4V for the MAX693A/MAX800M) and remain asserted for 200ms typ after V_{CC} rises above the reset threshold on power-up (Figure 5). The devices' battery-switchover comparator does not affect reset assertion. However, both reset outputs are asserted in battery-backup mode since V_{CC} must be below the reset threshold to enter this mode.

Watchdog Function

The watchdog monitors μP activity via the Watchdog Input (WDI). If the μP becomes inactive, $\overline{\text{RESET}}$ and $\overline{\text{RESET}}$ are asserted. To use the watchdog function, connect WDI to a bus line or μP I/O line. If WDI remains high or low for longer than the watchdog timeout period (1.6sec nominal), $\overline{\text{WDO}}$, $\overline{\text{RESET}}$, and $\overline{\text{RESET}}$ are asserted (see *RESET and RESET Outputs* section, and the *Watchdog Output* discussion on this page).

Watchdog Input

A change of state (high to low, low to high, or a minimum 100ns pulse) at the WDI during the watchdog period resets the watchdog timer. The watchdog default timeout is 1.6sec.

To disable the watchdog function, leave WDI floating. An internal resistor network (100k Ω equivalent impedance at WDI) biases WDI to approximately 1.6V. Internal comparators detect this level and disable the watchdog timer. When V_{CC} is below the reset threshold, the watchdog function is disabled and WDI is disconnected from its internal resistor network, thus becoming high impedance.

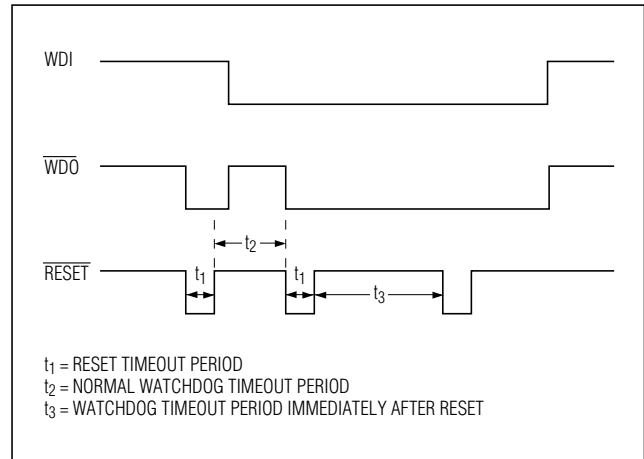

Figure 2. Watchdog Timeout Period and Reset Active Time

Watchdog Output

The Watchdog Output ($\overline{\text{WDO}}$) remains high if there is a transition or pulse at WDI during the watchdog timeout period. The watchdog function is disabled and $\overline{\text{WDO}}$ is a logic high when V_{CC} is below the reset threshold, battery-backup mode is enabled, or WDI is an open circuit. In watchdog mode, if no transition occurs at WDI during the watchdog timeout period, $\overline{\text{RESET}}$ and $\overline{\text{RESET}}$ are asserted for the reset timeout period (200ms typical). $\overline{\text{WDO}}$ goes low and remains low until the next transition at WDI (Figure 2). If WDI is held high or low indefinitely, $\overline{\text{RESET}}$ and $\overline{\text{RESET}}$ will generate 200ms pulses every 1.6sec. $\overline{\text{WDO}}$ has a 2 x TTL output characteristic.

Selecting an Alternative Watchdog and Reset Timeout Period

The OSC SEL and OSC IN inputs control the watchdog and reset timeout periods. Floating OSC SEL and OSC IN or tying them both to V_{OUT} selects the nominal 1.6sec watchdog timeout period and 200ms reset timeout period. Connecting OSC IN to GND and floating or connecting OSC SEL to V_{OUT} selects the 100ms normal watchdog timeout delay and 1.6sec delay immediately after reset. The reset timeout delay remains 200ms (Figure 2). Select alternative timeout periods by connecting OSC SEL to GND and connecting a capacitor between OSC IN and GND, or by externally driving OSC IN (Table 1 and Figure 3). OSC IN is internally connected to a $\pm 100\text{nA}$ (typ) current source that charges and discharges the timing capacitor to create the oscillator frequency, which sets the reset and watchdog timeout periods (see *Connecting a Timing Capacitor at OSC IN* in the *Applications Information* section).

Microprocessor Supervisory Circuits

MAX691A/MAX693A/MAX800L/MAX800M

Table 1. Reset Pulse Width and Watchdog Timeout Selections

OSC SEL	OSC IN	Watchdog Timeout Period		Reset Timeout Period
		Normal	Immediately After Reset	
Low	External Clock Input	1024 clks	4096 clks	2048 clks
Low	External Capacitor	$(600/47\text{pF} \times C)\text{ms}$	$(2.4/47\text{pF} \times C)\text{sec}$	$(1200/47\text{pF} \times C)\text{ms}$
Floating	Low	100ms	1.6sec	200ms
Floating	Floating	1.6sec	1.6sec	200ms

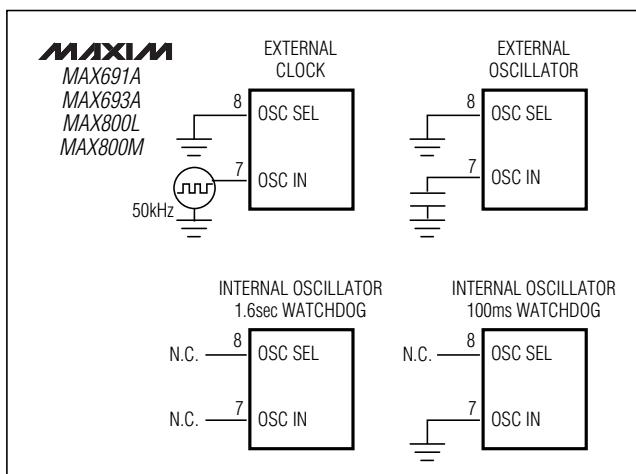

Figure 3. Oscillator Circuits

Chip-Enable Signal Gating

The MAX691A/MAX693A/MAX800L/MAX800M provide internal gating of chip-enable (CE) signals to prevent erroneous data from being written to CMOS RAM in the event of a power failure. During normal operation, the CE gate is enabled and passes all CE transitions. When reset is asserted, this path becomes disabled, preventing erroneous data from corrupting the CMOS RAM. All these parts use a series transmission gate from $\overline{\text{CE}} \text{ IN}$ to $\overline{\text{CE}} \text{ OUT}$ (Figure 4).

The 10ns max CE propagation delay from $\overline{\text{CE}} \text{ IN}$ to $\overline{\text{CE}} \text{ OUT}$ enables the parts to be used with most μPs .

Chip-Enable Input

The Chip-Enable Input ($\overline{\text{CE}} \text{ IN}$) is high impedance (disabled mode) while RESET and $\overline{\text{RESET}}$ are asserted.

During a power-down sequence where V_{CC} falls below the reset threshold or a watchdog fault, $\overline{\text{CE}} \text{ IN}$ assumes a high-impedance state when the voltage at $\overline{\text{CE}} \text{ IN}$ goes high or 15 μs after reset is asserted, whichever occurs first (Figure 5).

During a power-up sequence, $\overline{\text{CE}} \text{ IN}$ remains high impedance, regardless of $\overline{\text{CE}} \text{ IN}$ activity, until reset is deasserted following the reset timeout period.

In the high-impedance mode, the leakage currents into this terminal are $\pm 1\mu\text{A}$ max over temperature. In the low-impedance mode, the impedance of $\overline{\text{CE}} \text{ IN}$ appears as a 75 Ω resistor in series with the load at $\overline{\text{CE}} \text{ OUT}$.

The propagation delay through the CE transmission gate depends on both the source impedance of the drive to $\overline{\text{CE}} \text{ IN}$ and the capacitive loading on the Chip-Enable Output ($\overline{\text{CE}} \text{ OUT}$) (see Chip-Enable Propagation Delay vs. $\overline{\text{CE}} \text{ OUT}$ Load Capacitance in the *Typical Operating Characteristics*). The CE propagation delay is production tested from the 50% point of $\overline{\text{CE}} \text{ IN}$ to the 50% point of $\overline{\text{CE}} \text{ OUT}$ using a 50 Ω driver and 50pF of load capacitance (Figure 6). For minimum propagation delay, minimize the capacitive load at $\overline{\text{CE}} \text{ OUT}$, and use a low output-impedance driver.

Chip-Enable Output

In the enabled mode, the impedance of $\overline{\text{CE}} \text{ OUT}$ is equivalent to 75 Ω in series with the source driving $\overline{\text{CE}} \text{ IN}$. In the disabled mode, the 75 Ω transmission gate is off and $\overline{\text{CE}} \text{ OUT}$ is actively pulled to V_{OUT} . This source turns off when the transmission gate is enabled.

LOW LINE Output

$\overline{\text{LOW LINE}}$ is the buffered output of the reset threshold comparator. $\overline{\text{LOW LINE}}$ typically sinks 3.2mA at 0.1V. For normal operation (V_{CC} above the $\overline{\text{LOW LINE}}$ threshold), $\overline{\text{LOW LINE}}$ is pulled to V_{OUT} .

Power-Fail Comparator

The power-fail comparator is an uncommitted comparator that has no effect on the other functions of the IC. Common uses include low-battery indication (Figure 7), and early power-fail warning (see *Typical Operating Circuit*).

Power-Fail Input

Power Fail Input (PFI) is the input to the power-fail comparator. It has a guaranteed input leakage of $\pm 25\text{nA}$ max over temperature. The typical comparator delay is 25 μs from V_{IL} to V_{OL} (power failing), and 60 μs from V_{IH} to V_{OH} (power being restored). If PFI is not used, connect it to ground.

Microprocessor Supervisory Circuits

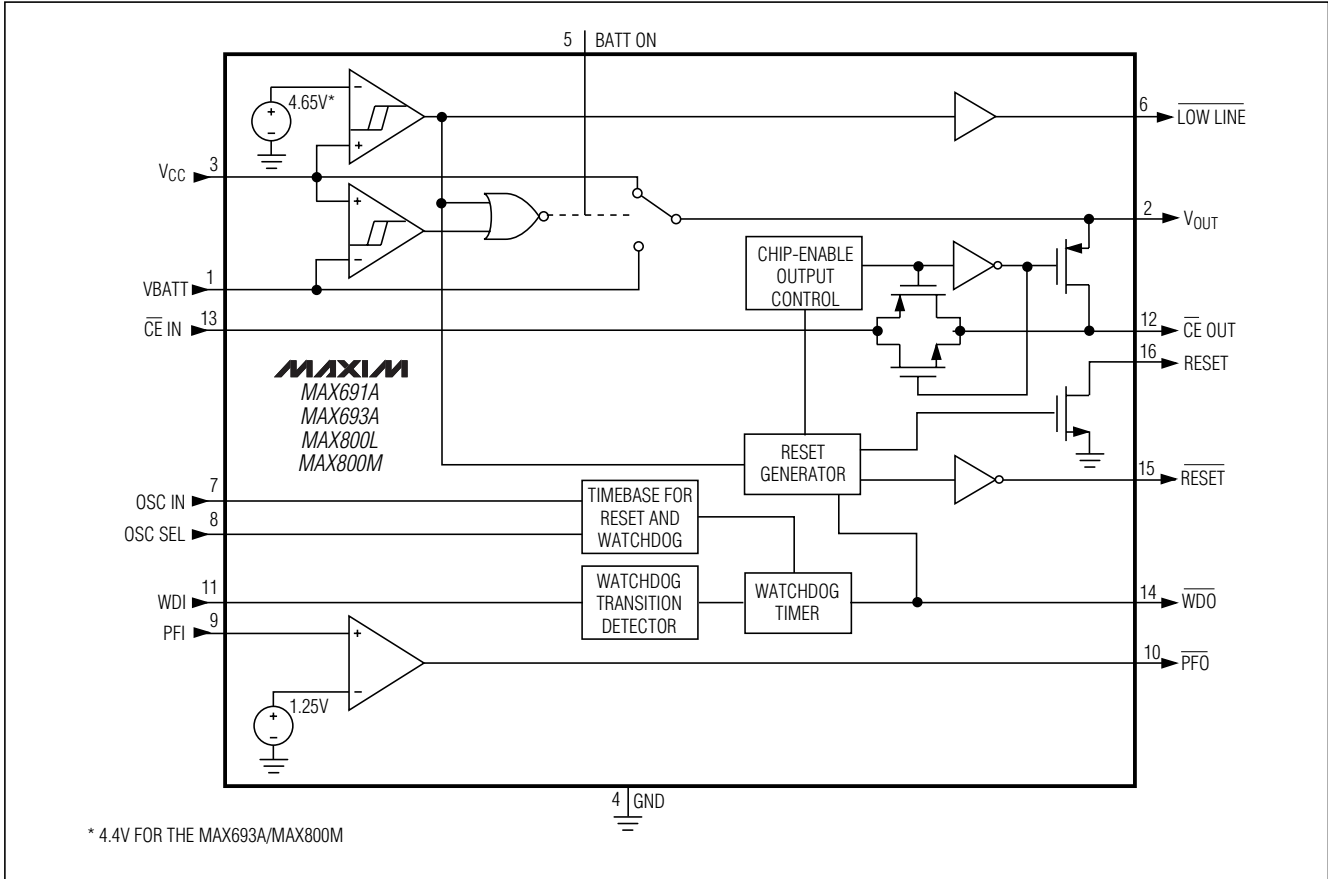

Figure 4. MAX691A/MAX693A/MAX800L/MAX800M Block Diagram

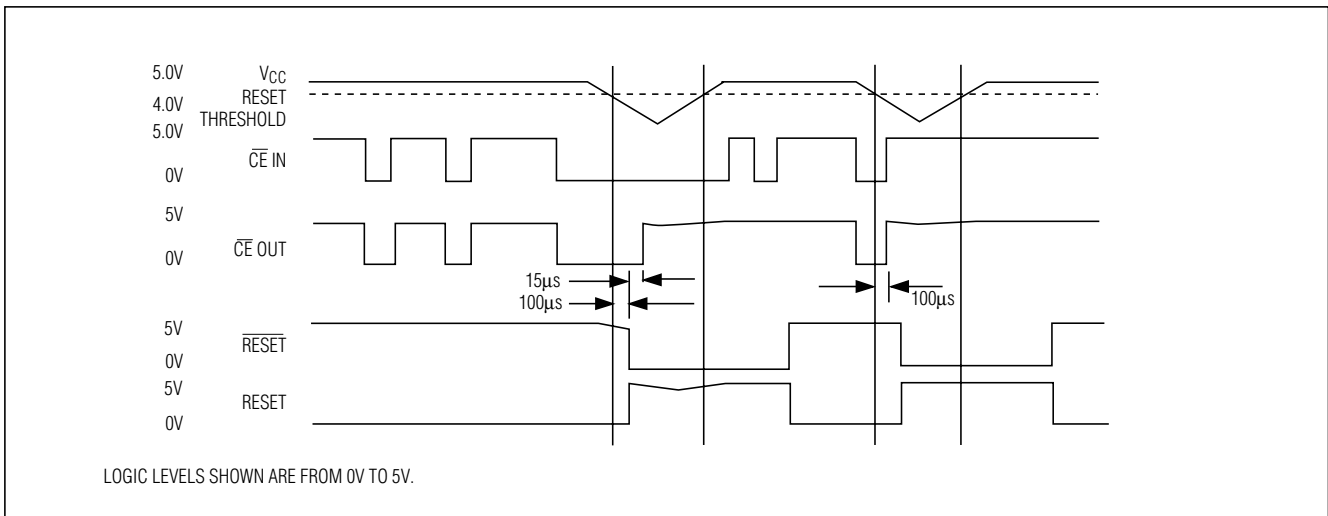

Figure 5. Reset and Chip-Enable Timing

Microprocessor Supervisory Circuits

MAX691A/MAX693A/MAX800L/MAX800M

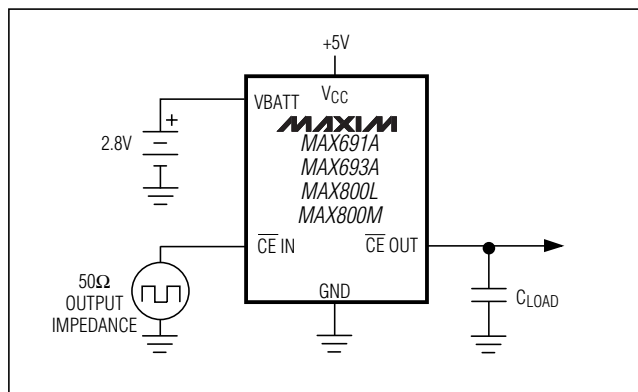

Figure 6. CE Propagation Delay Test Circuit

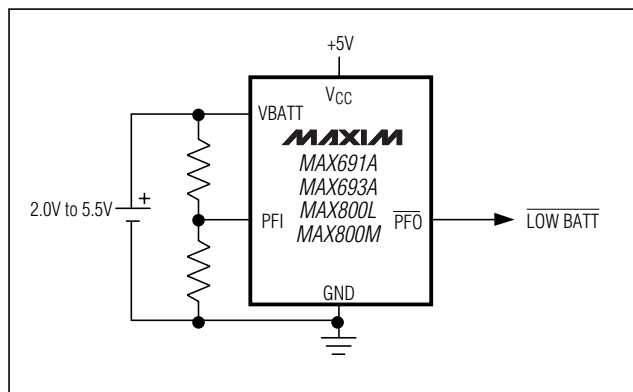

Figure 7. Low-Battery Indicator

Table 2. Input and Output Status in Battery-Backup Mode

PIN	NAME	STATUS
1	VBATT	Supply current is 1μA max.
2	V _{OUT}	V _{OUT} is connected to VBATT through an internal PMOS switch.
3	V _{CC}	Battery switchover comparator monitors V _{CC} for active switchover.
4	GND	GND 0V, 0V reference for all signals.
5	BATT ON	Logic high. The open-circuit output is equal to V _{OUT} .
6	LOWLINE	Logic low*
7	OSC IN	OSC IN is ignored.
8	OSC SEL	OSC SEL is ignored.
9	PFI	The power-fail comparator remains active in the battery-backup mode for V _{CC} ≥ VBATT - 1.2V typ.
10	PFO	The power-fail comparator remains active in the battery-backup mode for V _{CC} ≥ VBATT - 1.2V typ. Below this voltage, PFO is forced low.
11	WDI	Watchdog is ignored.
12	CE OUT	Logic high. The open-circuit voltage is equal to V _{OUT} .
13	CE IN	High impedance
14	WDO	Logic high. The open-circuit voltage is equal to V _{OUT} .
15	RESET	Logic low*
16	RESET	High impedance*

* V_{CC} must be below the reset threshold to enter battery-backup mode.

Power-Fail Output

The Power-Fail Output (PFO) goes low when PFI goes below 1.25V. It typically sinks 3.2mA with a saturation voltage of 0.1V. With PFI above 1.25V, PFO is actively pulled to V_{OUT}.

Battery-Backup Mode

Two conditions are required to switch to battery-backup mode: 1) V_{CC} must be below the reset threshold, and 2) V_{CC} must be below VBATT. Table 2 lists the status of the inputs and outputs in battery-backup mode.

Battery On Output

The Battery On (BATT ON) output indicates the status of the internal V_{CC}/battery-switchover comparator, which controls the internal V_{CC} and VBATT switches. For V_{CC} greater than VBATT (ignoring the small hysteresis effect), BATT ON typically sinks 3.2mA at 0.1V saturation voltage. In battery-backup mode, this terminal sources approximately 10μA from V_{OUT}. Use BATT ON to indicate battery-switchover status or to supply base drive to an external pass transistor for higher-current applications (see *Typical Operating Circuit*).

Input Supply Voltage

The Input Supply Voltage (V_{CC}) should be a regulated 5V. V_{CC} connects to V_{OUT} via a parallel diode and a large PMOS switch. The switch carries the entire current load for currents less than 250mA. The parallel diode carries any current in excess of 250mA. Both the switch and the diode have impedances less than 1Ω each. The maximum continuous current is 250mA, but power-on transients may reach a maximum of 1A.

Microprocessor Supervisory Circuits

Battery-Backup Input

The Battery-Backup Input (VBATT) is similar to the V_{CC} input except the PMOS switch and parallel diode are much smaller. Accordingly, the on-resistances of the diode and the switch are each approximately 10Ω . Continuous current should be limited to 25mA and peak currents (only during power-up) limited to 250mA. The reverse leakage of this input is less than $1\mu A$ over temperature and supply voltage (Figure 8).

Output Supply Voltage

The Output Supply Voltage (V_{OUT}) pin is internally connected to the substrate of the IC and supplies current to the external system and internal circuitry. All open-circuit outputs will, for example, assume the V_{OUT} voltage in their high states rather than the V_{CC} voltage. At the maximum source current of 250mA, V_{OUT} will typically be 200mV below V_{CC} . Decouple this terminal with a $0.1\mu F$ capacitor.

Applications Information

The MAX691A/MAX693A/MAX800L/MAX800M are not short-circuit protected. Shorting V_{OUT} to ground, other than power-up transients such as charging a decoupling capacitor, destroys the device.

All open-circuit outputs swing between V_{OUT} and GND rather than V_{CC} and GND.

If long leads connect to the chip inputs, insure that these leads are free from ringing and other conditions that would forward bias the chip's protection diodes.

There are three distinct modes of operation:

- 1) Normal operating mode with all circuitry powered up. Typical supply current from V_{CC} is $35\mu A$ while only leakage currents flow from the battery.
- 2) Battery-backup mode where V_{CC} is typically within 0.7V below VBATT. All circuitry is powered up and the supply current from the battery is typically less than $60\mu A$.
- 3) Battery-backup mode where V_{CC} is less than VBATT by at least 0.7V. VBATT supply current is $1\mu A$ max.

Using SuperCap or MaxCap with the MAX691A/MAX693A/MAX800L/MAX800M

VBATT has the same operating voltage range as V_{CC} , and the battery switchover threshold voltages are typically $\pm 30mV$ centered at VBATT, allowing use of a SuperCap and a simple charging circuit as a backup source (Figure 9).

If V_{CC} is above the reset threshold and VBATT is 0.5V above V_{CC} , current flows to V_{OUT} and V_{CC} from VBATT until the voltage at VBATT is less than 0.5V above V_{CC} . For example, with a SuperCap connected to VBATT and through a diode to V_{CC} , if V_{CC} quickly changes from 5.4V to 4.9V, the capacitor discharges through V_{OUT} and V_{CC} until VBATT reaches 5.1V typ. Leakage current through the SuperCap charging diode and the internal power diode eventually discharges the SuperCap to V_{CC} . Also, if V_{CC} and VBATT start from 0.1V above the reset threshold and power is lost at V_{CC} , the SuperCap on VBATT discharges through V_{CC} until VBATT reaches the reset threshold; then the battery-backup mode is initiated and the current through V_{CC} goes to zero.

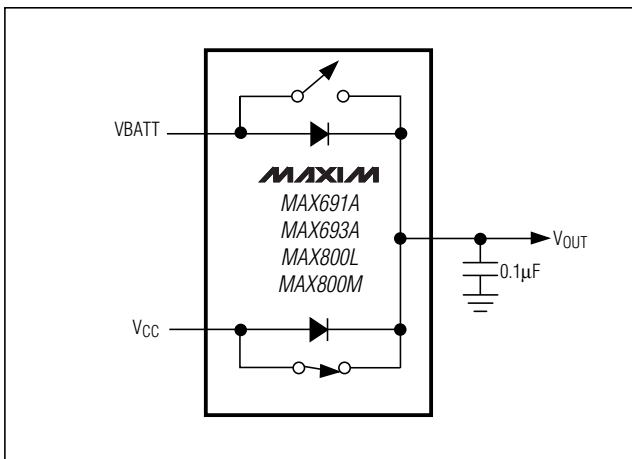

Figure 8. V_{CC} and VBATT to V_{OUT} Switch

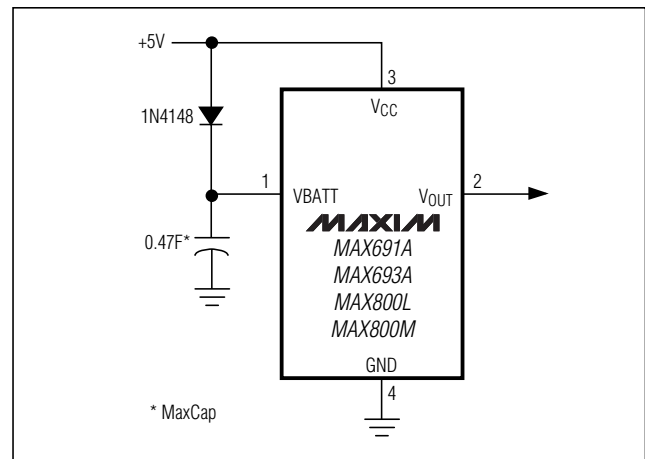

Figure 9. SuperCap or MaxCap on VBATT

Microprocessor Supervisory Circuits

MAX691A/MAX693A/MAX800L/MAX800M

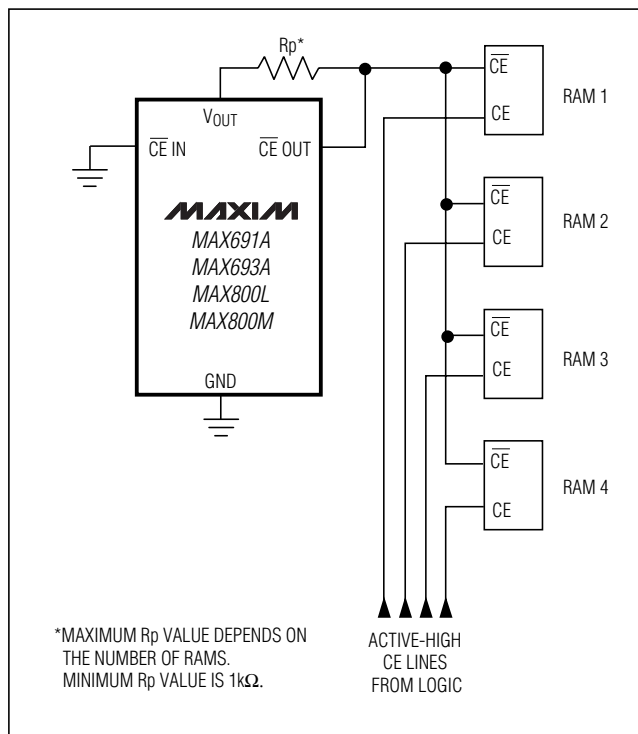

Figure 10. Alternate CE Gating

Using Separate Power Supplies for VBATT and VCC

If using separate power supplies for V_{CC} and VBATT, VBATT must be less than 0.3V above V_{CC} when V_{CC} is above the reset threshold. As described in the previous section, if VBATT exceeds this limit and power is lost at V_{CC}, current flows continuously from VBATT to V_{CC} via the VBATT-to-V_{OUT} diode and the V_{OUT}-to-V_{CC} switch until the circuit is broken (Figure 8).

Alternate Chip-Enable Gating

Using memory devices with both CE and $\overline{\text{CE}}$ inputs allows the CE loop to be bypassed. To do this, connect $\overline{\text{CE}}$ IN to ground, pull up $\overline{\text{CE}}$ OUT to V_{OUT}, and connect $\overline{\text{CE}}$ OUT to the $\overline{\text{CE}}$ input of each memory device (Figure 10). The CE input of each part then connects directly to the chip-select logic, which does not have to be gated.

Adding Hysteresis to the Power-Fail Comparator

Hysteresis adds a noise margin to the power-fail comparator and prevents repeated triggering of PFO when V_{IN} is near the power-fail comparator trip point. Figure 11 shows how to add hysteresis to the power-fail com-

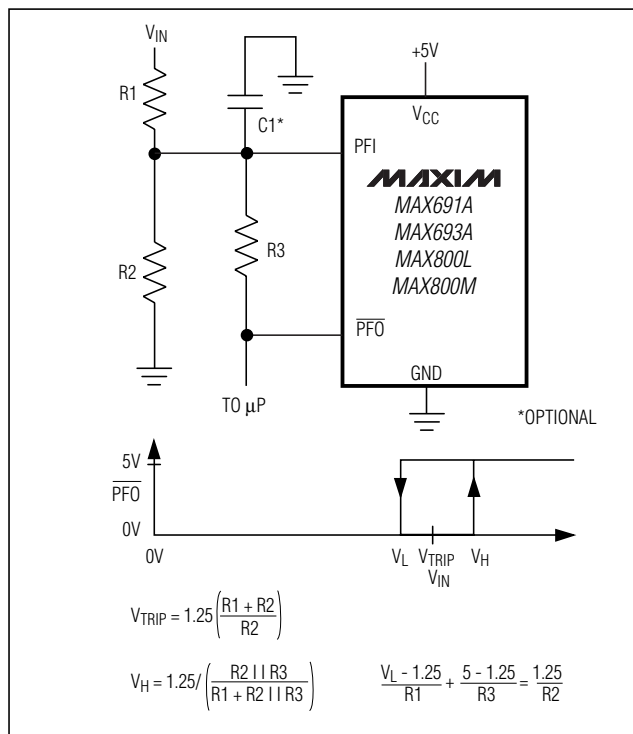

Figure 11. Adding Hysteresis to the Power-Fail Comparator

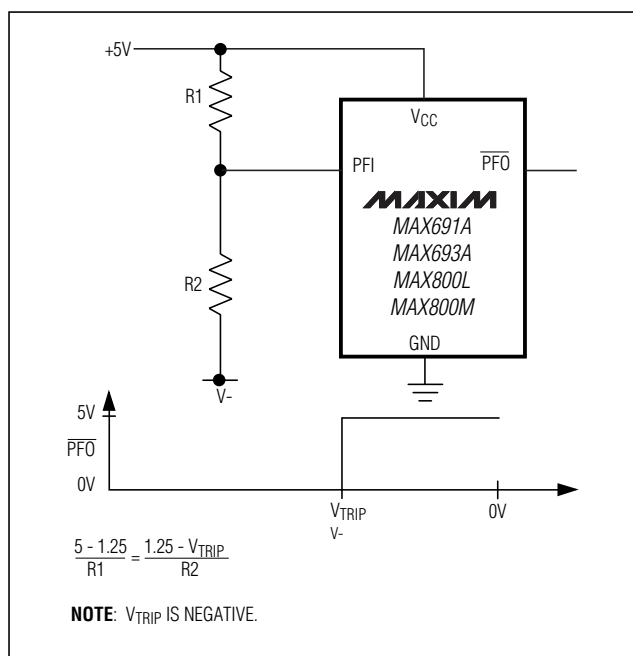

Figure 12. Monitoring a Negative Voltage

Microprocessor Supervisory Circuits

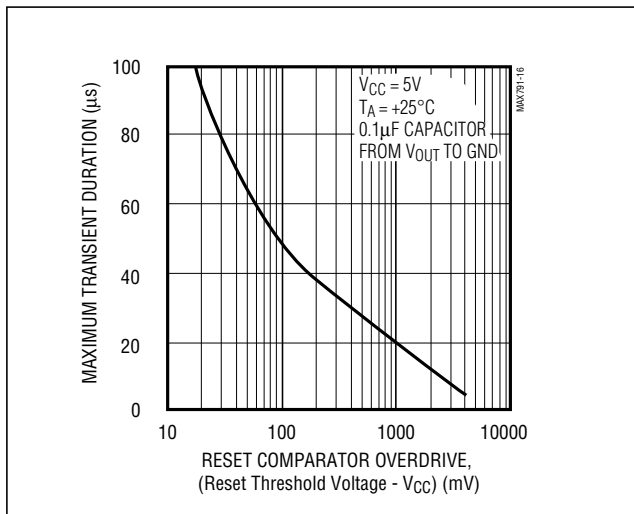

Figure 13. Maximum Transient Duration without Causing a Reset Pulse vs. Reset Comparator Overdrive

parator. Select the ratio of R1 and R2 such that PFI sees 1.25V when V_{IN} falls to the desired trip point (V_{TRIP}). Resistor R3 adds hysteresis. It will typically be an order of magnitude greater than R1 or R2. The current through R1 and R2 should be at least $1\mu\text{A}$ to ensure that the 25nA (max) PFI input current does not shift the trip point. R3 should be larger than $10\text{k}\Omega$ to prevent it from loading down the PFO pin. Capacitor C1 adds noise rejection.

Monitoring a Negative Voltage

The power-fail comparator can be used to monitor a negative supply voltage using Figure 12's circuit. When the negative supply is valid, PFO is low. When the negative supply voltage drops, PFO goes high. This circuit's accuracy is affected by the PFI threshold tolerance, the V_{CC} voltage, and resistors R1 and R2.

Backup-Battery Replacement

The backup battery may be disconnected while V_{CC} is above the reset threshold. No precautions are necessary to avoid spurious reset pulses.

Negative-Going V_{CC} Transients

While issuing resets to the μP during power-up, power-down, and brownout conditions, these supervisors are relatively immune to short-duration, negative-going V_{CC} transients (glitches). It is usually undesirable to reset the μP when V_{CC} experiences only small glitches.

Figure 13 shows maximum transient duration vs. reset-comparator overdrive, for which reset pulses are **not** generated. The graph was produced using negative-going V_{CC} pulses, starting at 5V and ending below the reset threshold by the magnitude indicated (reset-comparator overdrive). The graph shows the maximum pulse width a negative-going V_{CC} transient may typically have without causing a reset pulse to be issued. As the amplitude of the transient increases (i.e., goes farther below the reset threshold), the maximum allowable pulse width decreases. Typically, a V_{CC} transient that goes 100mV below the reset threshold and lasts for $40\mu\text{s}$ or less will not cause a reset pulse to be issued.

A 100nF bypass capacitor mounted close to the V_{CC} pin provides additional transient immunity.

Connecting a Timing Capacitor at OSC IN

When OSC SEL is connected to ground, OSC IN disconnects from its internal $10\mu\text{A}$ (typ) pull-up and is internally connected to a $\pm 100\text{nA}$ current source. When a capacitor is connected from OSC IN to ground (to select alternative reset and watchdog timeout periods), the current source charges and discharges the timing capacitor to create the oscillator that controls the reset and watchdog timeout period. To prevent timing errors or oscillator start-up problems, minimize external current leakage sources at this pin, and locate the capacitor as close to OSC IN as possible. The sum of PC-board leakage plus OSC capacitor leakage must be small compared to $\pm 100\text{nA}$.

Microprocessor Supervisory Circuits

Maximum V_{CC} Fall Time

The V_{CC} fall time is limited by the propagation delay of the battery switchover comparator and should not exceed 0.03V/μs. A standard rule of thumb for filter capacitance on most regulators is on the order of 100μF per amp of current. When the power supply is shut off or the main battery is disconnected, the associated initial V_{CC} fall rate is just the inverse or 1A/100μF = 0.01V/μs. The V_{CC} fall rate decreases with time as V_{CC} falls exponentially, which more than satisfies the maximum fall-time requirement.

Watchdog Software Considerations

A way to help the watchdog timer keep a closer watch on software execution involves setting and resetting the watchdog input at different points in the program, rather than “pulsing” the watchdog input high-low-high or low-high-low. This technique avoids a “stuck” loop where the watchdog timer continues to be reset within the loop, keeping the watchdog from timing out. Figure 14 shows an example flow diagram where the I/O driving the watchdog input is set high at the beginning of the program, set low at the beginning of every subroutine or loop, then set high again when the program returns to the beginning. If the program should “hang” in any subroutine, the I/O is continually set low and the watchdog timer is allowed to time out, causing a reset or interrupt to be issued.

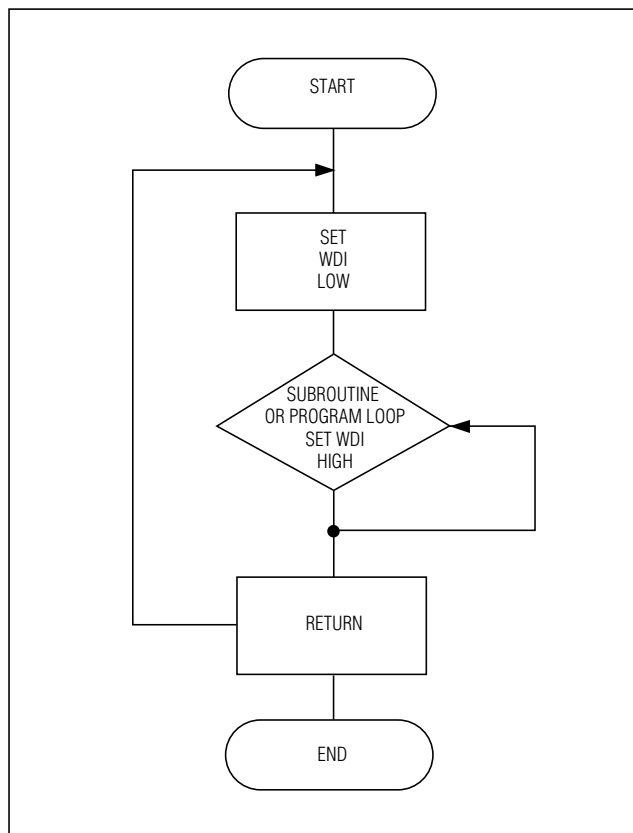

Figure 14. Watchdog Flow Diagram

Microprocessor Supervisory Circuits

Ordering Information (continued)

PART	TEMP. RANGE	PIN-PACKAGE
MAX693ACUE	0°C to +70°C	16 TSSOP
MAX693ACSE	0°C to +70°C	16 Narrow SO
MAX693ACWE	0°C to +70°C	16 Wide SO
MAX693ACPE	0°C to +70°C	16 Plastic DIP
MAX693AC/D	0°C to +70°C	Dice*
MAX693AEUE	-40°C to +85°C	16 TSSOP
MAX693AESE	-40°C to +85°C	16 Narrow SO
MAX693AEWE	-40°C to +85°C	16 Wide SO
MAX693AEPE	-40°C to +85°C	16 Plastic SO
MAX693AEJE	-40°C to +85°C	16 CERDIP
MAX693AMJE	-55°C to +125°C	16 CERDIP
MAX800LCUE	0°C to +70°C	16 TSSOP
MAX800LCSE	0°C to +70°C	16 Narrow SO
MAX800LCPE	0°C to +70°C	16 Plastic DIP
MAX800LEUE	-40°C to +85°C	16 TSSOP
MAX800LESE	-40°C to +85°C	16 Narrow SO
MAX800LEPE	-40°C to +85°C	16 Plastic DIP
MAX800MCUE	0°C to +70°C	16 TSSOP
MAX800MCSE	0°C to +70°C	16 Narrow SO
MAX800MCPE	0°C to +70°C	16 Plastic DIP
MAX800MEUE	-40°C to +85°C	16 TSSOP
MAX800MESE	-40°C to +85°C	16 Narrow SO
MAX800MEPE	-40°C to +85°C	16 Plastic DIP

* Dice are specified at $T_A = +25^\circ\text{C}$, DC parameters only.

Chip Topography

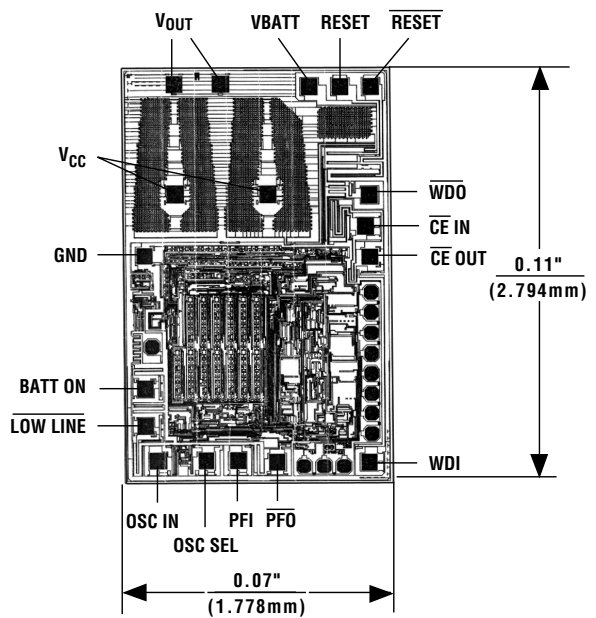

TRANSISTOR COUNT: 729
SUBSTRATE CONNECTED TO V_{OUT}

Microprocessor Supervisory Circuits

Package Information

(The package drawing(s) in this data sheet may not reflect the most current specifications. For the latest package outline information, go to www.maxim-ic.com/packages.)

MAX691A/MAX693A/MAX800L/MAX800M

TSSOP/EP

SYMBOL	COMMON DIMENSIONS			
	MILLIMETERS		INCHES	
	MIN.	MAX.	MIN.	MAX.
A	—	1.10	—	.043
A ₁	0.05	0.15	.002	.006
A ₂	0.85	0.95	.033	.037
b	0.19	0.30	.007	.012
b ₁	0.19	0.25	.007	.010
c	0.090	0.20	.0035	.008
c ₁	0.090	0.135	.0035	.0053
D	SEE VARIATIONS		SEE VARIATIONS	
E	4.30	4.50	.169	.177
e	0.65 BSC		.026 BSC	
H	6.25	6.50	.246	.256
L	0.50	0.70	.020	.028
N	SEE VARIATIONS		SEE VARIATIONS	
Y	2.85	3.15	.112	.124
α	0°	8°	0°	8°

JEDEC	N		VARIATIONS			
			MILLIMETERS		INCHES	
			MIN.	MAX.	MIN.	MAX.
AB	14	D	4.90	5.10	.193	.201
AC	16	D	4.90	5.10	.193	.201
AC-EP	16	D	4.90	5.10	.193	.201
		X	2.85	3.15	.112	.124
AD	20	D	6.40	6.60	.252	.260
AD-EP	20	D	6.40	6.60	.252	.260
		X	4.00	4.34	.157	.171
AE	24	D	7.70	7.90	.303	.311
AF	28	D	9.60	9.80	.378	.386
AF-EP	28	D	9.60	9.80	.378	.386
		X	5.35	5.65	.211	.222

NOTES:

- DIMENSIONS D AND E DO NOT INCLUDE FLASH.
- MOLD FLASH OR PROTRUSIONS NOT TO EXCEED .15 mm PER SIDE.
- CONTROLLING DIMENSION: MILLIMETER.
- MEETS JEDEC OUTLINE MO-153 VARIATIONS AB, AC, AD, AE, AF.
- DIMENSIONS X AND Y APPLY TO EXPOSED PAD (EP) VERSIONS ONLY.
- EXPOSED PAD FLUSH WITH BOTTOM OF PACKAGE WITHIN .002".

Microprocessor Supervisory Circuits

Package Information (continued)

(The package drawing(s) in this data sheet may not reflect the most current specifications. For the latest package outline info go to www.maxim-ic.com/packages.)

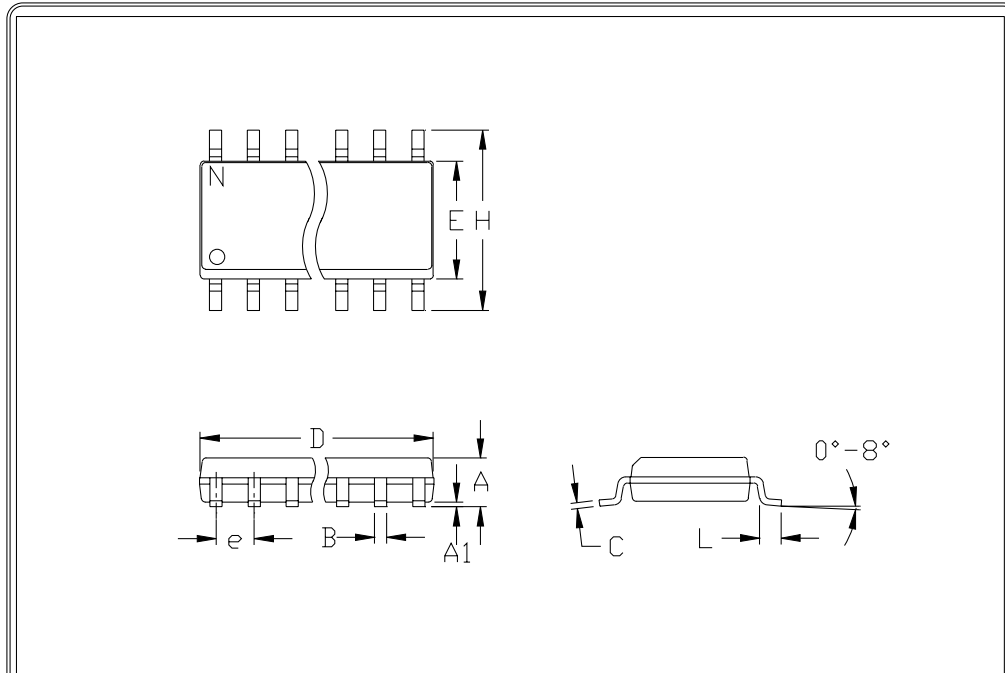

	INCHES		MILLIMETERS	
	MIN	MAX	MIN	MAX
A	0.053	0.069	1.35	1.75
A1	0.004	0.010	0.10	0.25
B	0.014	0.019	0.35	0.49
C	0.007	0.010	0.19	0.25
e	0.050		1.27	
E	0.150	0.157	3.80	4.00
H	0.228	0.244	5.80	6.20
h	0.010	0.020	0.25	0.50
L	0.016	0.050	0.40	1.27

	INCHES		MILLIMETERS			
	MIN	MAX	MIN	MAX	N	MS012
D	0.189	0.197	4.80	5.00	8	A
D	0.337	0.344	8.55	8.75	14	B
D	0.386	0.394	9.80	10.00	16	C

- NOTES:
1. D&E DO NOT INCLUDE MOLD FLASH
 2. MOLD FLASH OR PROTRUSIONS NOT TO EXCEED .15mm (.006")
 3. LEADS TO BE COPLANAR WITHIN .102mm (.004")
 4. CONTROLLING DIMENSION: MILLIMETER
 5. MEETS JEDEC MS012-XX AS SHOWN IN ABOVE TABLE
 6. N = NUMBER OF PINS



PACKAGE FAMILY OUTLINE: SOIC .150" TITLE



21-0041 A DOCUMENT CONTROL NUMBER REV

Microprocessor Supervisory Circuits

Package Information (continued)

(The package drawing(s) in this data sheet may not reflect the most current specifications. For the latest package outline info go to www.maxim-ic.com/packages.)

MAX691A/MAX693A/MAX800L/MAX800M

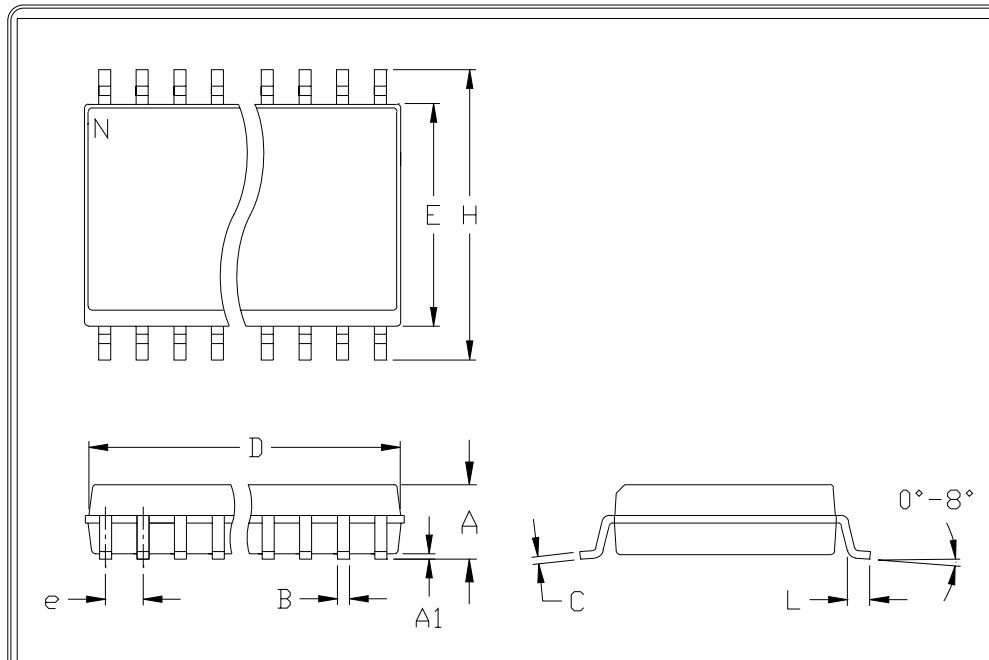

	INCHES		MILLIMETERS	
	MIN	MAX	MIN	MAX
A	0.093	0.104	2.35	2.65
A1	0.004	0.012	0.10	0.30
B	0.014	0.019	0.35	0.49
C	0.009	0.013	0.23	0.32
e	0.050		1.27	
E	0.291	0.299	7.40	7.60
H	0.394	0.419	10.00	10.65
h	0.010	0.030	0.25	0.75
L	0.016	0.050	0.40	1.27

	INCHES		MILLIMETERS		N	MS013
	MIN	MAX	MIN	MAX		
D	0.398	0.413	10.10	10.50	16	AA
D	0.447	0.463	11.35	11.75	18	AB
D	0.496	0.512	12.60	13.00	20	AC
D	0.598	0.614	15.20	15.60	24	AD
D	0.697	0.713	17.70	18.10	28	AE

- NOTES:
1. D&E DO NOT INCLUDE MOLD FLASH
 2. MOLD FLASH OR PROTRUSIONS NOT TO EXCEED .15mm (.006")
 3. LEADS TO BE COPLANAR WITHIN .102mm (.004")
 4. CONTROLLING DIMENSION: MILLIMETER
 5. MEETS JEDEC MS013-XX AS SHOWN IN ABOVE TABLE
 6. N = NUMBER OF PINS



PACKAGE FAMILY OUTLINE: SOIC .300"
TITLE



21-0042 A
DOCUMENT CONTROL NUMBER REV

Maxim cannot assume responsibility for use of any circuitry other than circuitry entirely embodied in a Maxim product. No circuit patent licenses are implied. Maxim reserves the right to change the circuitry and specifications without notice at any time.

Maxim Integrated Products, 120 San Gabriel Drive, Sunnyvale, CA 94086 408-737-7600 19