

Safety Switches

Interlock Switches

Overview

Versatility

Many safety switches allow the head of the switch to rotate, offering different options on how the switch can be operated and mounted on the guard. This offers flexibility to best fit typical applications.

Elf, Cadet3, MT-GD2, 440G-MT

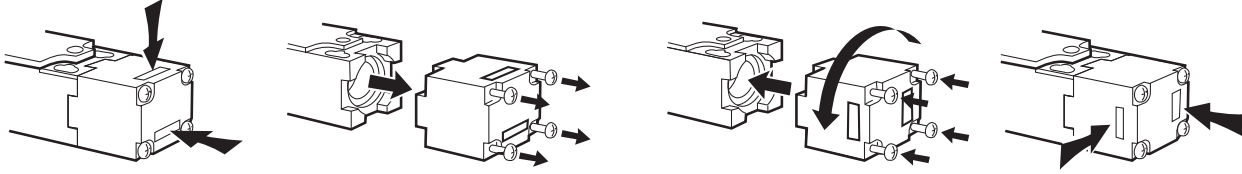

The head can be rotated 4 times at 90° allowing the key to fit the switch in 8 different positions.

Trojan T15, Trojan 5, Trojan 6 (Not GD2 Models)

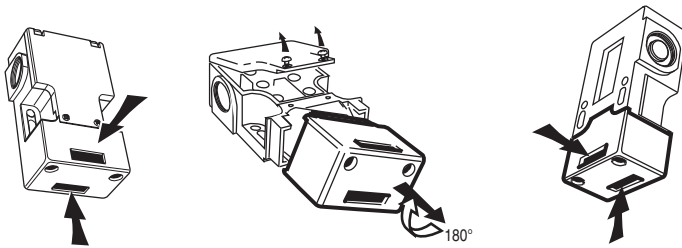

The head rotates 180° allowing the key to fit the switch in 4 different positions: 2 in the front, 1 in the top and 1 in the back.

TLS-GD2

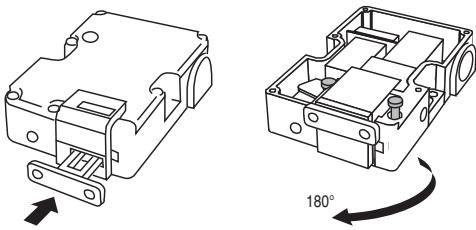

The head rotates 180° allowing the key to fit the switch in 4 different positions: 2 in the front, 1 in the top and 1 in the back.

Sprite, Ensign

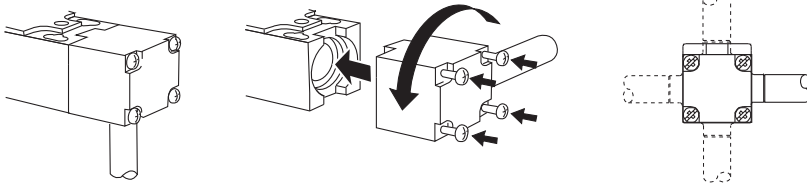

The head can be rotated 4 times at 90° allowing the switch to be mounted in 4 different positions.

Accessories for Tongue and Guard Locking Switches



The correct actuator for your application

A large variety of tongue actuators are available:

Standard: 90°, Flat, Standard



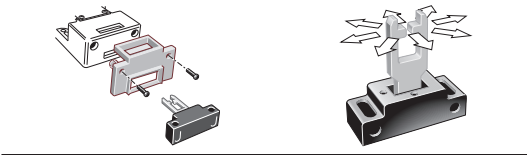
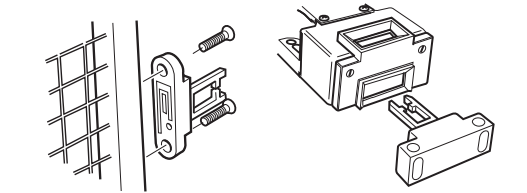











Flexible: Semi and Fully

Specialty: Extended Flat and GD2 models

| | |
|--|---|
|  | <p><i>Standard type</i> actuators accommodate most of the applications. Their design allows for the actuator and the switch to be mounted in different position and the guard to work properly. The flat actuator is mounted on small rubber blocks allowing for some play when the guard closes. The 90° is typically used on sliding doors.</p> |
|  | <p><i>Flexible type</i> actuators are used when doors are sagging or are not sturdy enough to guarantee insertion of the actuator always in-line with the opening of the switch. The flexible actuator allows for some motion of the actuator to "self" align with the opening of the switch. Fully flexible actuators allow the actuator to move within a 15° angle in any direction. Semi-flexible actuators can be used for tight angles where the actuator enters the switch at an angle. This angle is adjustable on the actuator. The semi-flexible actuator moves only in a single plan direction.</p> |
|  | <p><i>GD2</i> actuators are dedicated actuators for GD2 models and are not suitable for use with standard models.</p> |
|  | <p><i>Extended flat type</i> actuator is used mostly when the actuator is mounted on a chain and inserted in the switch. The guard is latched and the key is just inserted in the switch attached to a chain. When the door opens, the chain pulls the actuator activating the safety contacts.</p> |

Safety Switches
Interlock Switches
 Overview

Product Selection

| Description | | Elf | Cadet 3 | T15 | T15 GD2 | T5-T6 | T5 GD2-T6 GD2 | MT-GD2 | TLS GD2 | Atlas 5 | 440G-MT | Cat. No. |
|--|---|-----|---------|-----|---------|-------|---------------|--------|---------|---------|---------|-------------|
| Standard actuator |  | | | | | ✓ | | | | | | 440K-A11095 |
| Standard actuator |  | | | ✓ | | | | | | | | 440K-A11238 |
| Standard actuator |  | | | | | | | | | ✓ | | 440G-A07136 |
| GD2 standard actuator |  | | | | ✓ | | ✓ | ✓ | ✓ | | ✓ | 440G-A27011 |
| Flat actuator, not to be used with metal alignment guide |  | ✓ | ✓ | | | | | | | | | 440K-A21014 |
| GD2 flat actuator |  | | | | ✓ | | ✓ | ✓ | ✓ | | ✓ | 440K-A11112 |
| 90° actuator, not to be used with metal alignment guide |  | ✓ | ✓ | | | | | | | | | 440K-A21006 |
| Fully flex actuator |  | | | | ✓ | | ✓ | ✓ | ✓ | | ✓ | 440G-A27143 |
| Fully flex actuator |  | | | | | | | | | ✓ | | 440G-A07269 |
| Extended flat actuator |  | | | | ✓ | | ✓ | ✓ | ✓ | | ✓ | 440K-A17116 |
| Metal alignment guide with semi-flexible actuator |  | ✓ | ✓ | | | | | | | | | 440K-A21030 |
| Alignment guide with semi-flexible actuator |  | | | ✓ | ✓ | ✓ | ✓ | ✓ | | | | 440K-A11144 |
| Alignment guide with fully-flexible actuator |  | | | ✓ | | ✓ | | | | | | 440K-A27010 |
| Catch and Retainer Kit |  | | | | | ✓ | | | | | | 440K-A11094 |
| Replacement Alignment Guide |  | | | | | ✓ | | | | | | 440K-A11115 |

3-Interlock Switches

Safety Switches
Tongue Switches
Trojan™ T15

Accessories

| | Description | To Be Used With: | Dimensions | Cat. No. |
|---|--|--|------------|-------------|
|  | Standard actuator | Trojan T15 Standard Models Only | 3-51 | 440K-A11238 |
|  | GD2 standard actuator | Trojan GD2 Models Only | 3-50 | 440G-A27011 |
|  | GD2 flat actuator | Trojan GD2 Models Only | 3-51 | 440K-A11112 |
|  | Alignment guide with semi-flexible actuator | Discard Alignment Guide for GD2 Models | | 440K-A11144 |
|  | Alignment guide with fully-flexible actuator | Discard Alignment Guide for GD2 Models | | 440K-A27010 |
|  | Sliding bolt actuator | Trojan GD2 Models Only | 3-55 | 440G-A27163 |
|  | Catch and Retainer Kit | Trojan T15 Standard Models Only | 3-50 | 440K-A11094 |
|  | Replacement Cover | All Models | — | 440A-A11499 |
|  | Dust Cover | All Models | — | 440K-A17180 |

3-Interlock Switches





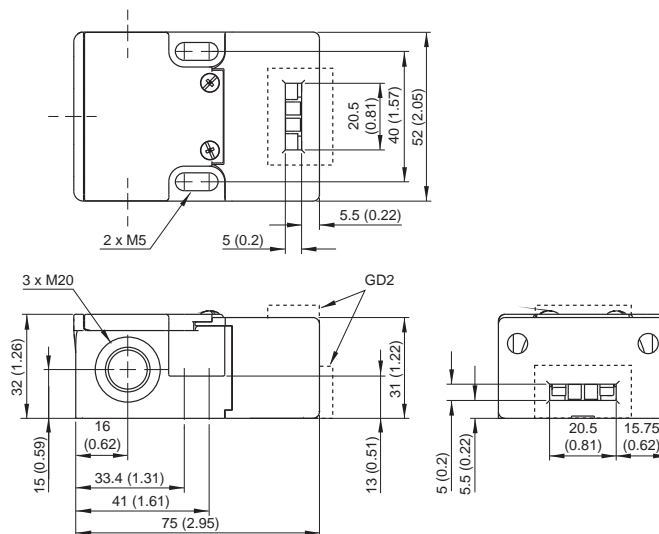



Approximate Dimensions

Dimensions are shown in mm (in.). Dimensions are not intended to be used for installation purposes.









Note: 2D, 3D and electrical drawings are available on www.ab.com.

Accessories

| | Description | To Be Used With: | Dimensions | Cat. No. |
|---|--|--|------------|-------------|
|  | Standard actuator | Trojan T5 and T6 Standard Models Only | 3-51 | 440K-A11095 |
|  | GD2 standard actuator | GD2 Models Only | 3-50 | 440G-A27011 |
|  | GD2 flat actuator | GD2 Models Only | 3-51 | 440K-A11112 |
|  | Alignment guide with semi-flexible actuator | Discard Alignment Guide for GD2 Models | 3-51 | 440K-A11144 |
|  | Alignment guide with fully-flexible actuator | Discard Alignment Guide for GD2 Models | 3-52 | 440K-A27010 |
|  | Sliding bolt actuator | GD2 Models Only | 3-55 | 440G-A27163 |
|  | Catch and Retainer Kit | Trojan T5 and T6 Standard Models Only | 3-50 | 440K-A11094 |
|  | Replacement Cover | Trojan T5 Standard Models Only | — | 440A-A11495 |
| | | Trojan T5 GD2 | | 440A-A11496 |
| | | Trojan T6 Standard Models Only | | 440A-A11497 |
| | | Trojan T6 GD2 | | 440A-A11498 |
|  | Dust Cover | All Models | — | 440K-A17180 |

Accessories

| | Description | Dimensions | Cat. No. |
|---|------------------------|------------|-------------|
|  | GD2 standard actuator | 3-50 | 440G-A27011 |
|  | GD2 flat actuator | 3-51 | 440K-A11112 |
|  | Fully flex actuator | 3-50 | 440G-A27143 |
|  | Sliding bolt actuator | 3-55 | 440G-A27163 |
|  | Extended flat actuator | 3-51 | 440K-A17116 |
|  | Dust Cover | — | 440K-A17180 |

Approximate Dimensions

Dimensions are shown in mm (in.). Dimensions are not intended to be used for installation purposes.

MT-GD2 Latch Release

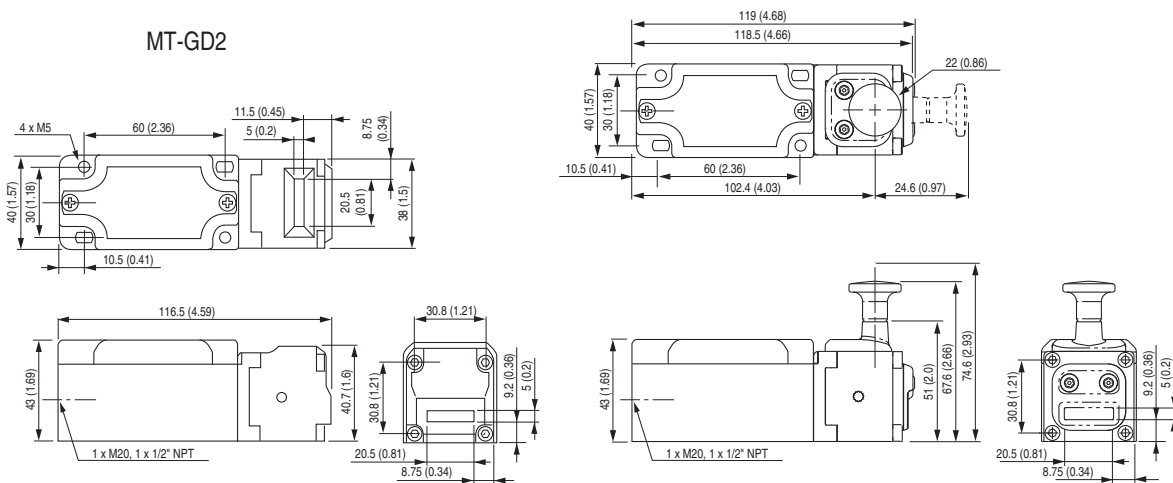

Note: 2D, 3D and electrical drawings are available on www.ab.com.

Safety Switches

Guard Locking Switches









440G-MT

Connection Systems

| Description | 8-Pin Micro | 12-Pin M23 |
|-------------|---------------|----------------|
| Cordset | 889D-F8AB-* | 889M-F12AH-* |
| Patchcord | 889D-F8ABDM-* | 889M-F12AHMU-† |

- * Replace symbol with 2 (2 m), 5 (5 m), or 10 (10 m) for standard cable lengths.
 - ⊛ Replace symbol with 1 (1 m), 2 (2 m), 3 (3 m), 5 (5 m), or 10 (10 m) for standard cable lengths.
 - † Replace symbol with 0M3, (0.3 m), 0M6 (0.6 m), 1 (1 m), 2 (2 m) or 3 (3 m) for standard lengths.
- Note:** For additional information, see page 7-1.

Accessories

| Description | Dimensions | Cat. No. |
|---|------------|--------------------|
|  GD2 standard actuator | 3-50 | 440G-A27011 |
|  GD2 flat actuator | | 440K-A11112 |
|  Fully flex actuator | | 440G-A27143 |
|  Sliding bolt actuator | | 440G-A27163 |
|  Extended flat actuator | | 440K-A17116 |
|  Replacement Cover, No LED, No Override Key | — | 440G-MT47120 |
|  Replacement Cover, LED, Override Key | | 440G-MT47123 |
|  Emergency Override Key (See Warning below.) | — | 440G-A36026 |
|  Dust Cover | — | 440K-A17180 |



WARNING: Do not attach the Emergency Override Key to the 440G-MT switch.





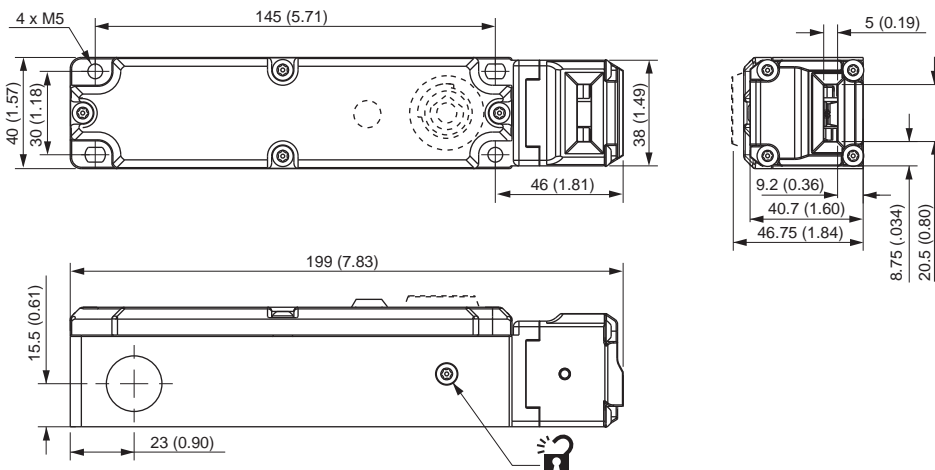





Approximate Dimensions

Dimensions are shown in mm (in.). Dimensions are not intended to be used for installation purposes.



Note: 2D, 3D and electrical drawings are available on www.ab.com.

Accessories

| | Description | Dimensions | Cat. No. |
|---|---|------------|---------------|
|  | GD2 standard actuator | 3-50 | 440G-A27011 |
|  | GD2 flat actuator | 3-51 | 440K-A11112 |
|  | Extended flat actuator | 3-51 | 440K-A17116 |
|  | Fully flex actuator | 3-50 | 440G-A27143 |
|  | Sliding bolt actuator not to be used with the Escape Release | 3-55 | 440G-A27163 |
|  | Cover for TLS-1 with external override key for series D and earlier | — | 440G-A27140 |
| | Cover for TLS-3 with external override key for series D and earlier | | 440G-A27142 |
| | Cover for TLS-1 with override key attached for series D and earlier | | 440G-A27207 |
| | Cover for TLS-3 with override key attached for series D and earlier | | 440G-A27208 |
| | Cover for TLS-1 with external override key for series E and later | | 440G-A27371 |
| | Cover for TLS-3 with external override key for series E and later | | 440G-A27372 |
| | Cover for TLS-1 with override key attached for series E and later | | 440G-A27373 |
| Cover for TLS-3 with override key attached for series E and later | 440G-A27374 | | |
|  | Emergency Override Key (See Warning below.) | — | 440G-A36026 |
|  | Flexible Release—1 m (3.28 ft) Cable | 3-54 | 440G-A27356 |
| | Flexible Release—3 m (9.84 ft) Cable | | 440G-A27357 |
|  | Dust Cover | — | 440K-A17183 |
|  | Sliding Bolt | 3-55 | 440K-AMDS |
|  | Mounting Plate | 3-55 | 440K-AMDSSMPB |









3-Interlock
Switches

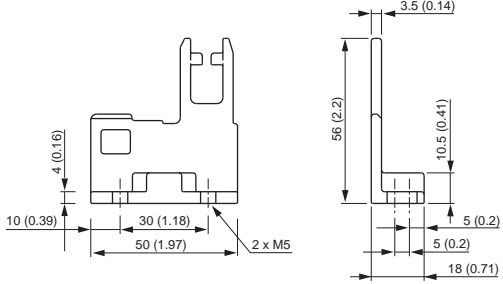

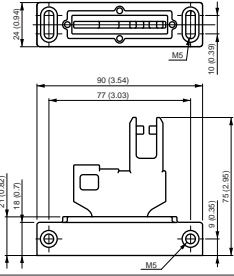
WARNING: Do not attach the Emergency Override Key to the TLS-GD2 switch.

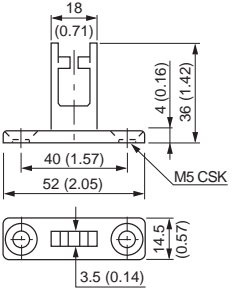
Accessories for Interlock and Guard Locking Switches

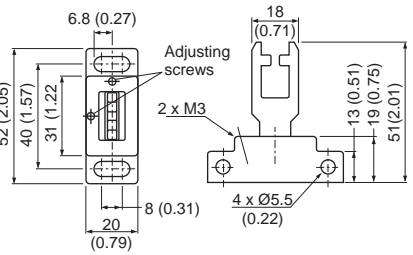
Actuators*

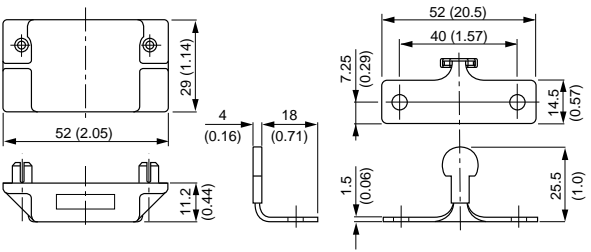
| Item | Description | Approximate Dimensions [mm (in.)] | Cat. No. |
|---|------------------------|---|-------------|
|  | Standard actuator |  <p>Dimensions: 10 (0.39), 4 (0.16), 30 (1.18), 50 (1.97), 2 x M5, 56 (2.2), 3.5 (0.14), 10.5 (0.41), 5 (0.2), 5 (0.2), 18 (0.71)</p> | 440G-A07136 |
|  | Fully flex actuator |  <p>Dimensions: 24 (0.94), 90 (3.54), 77 (3.03), 10 (0.39), 21 (0.83), 18 (0.71), 9 (0.35), 75 (2.95), M5</p> | 440G-A07269 |
|  | GD2 standard actuator |  <p>Dimensions: 18 (0.71), 4 (0.16), 36 (1.42), 40 (1.57), 52 (2.05), M5 CSK, 14.5 (0.57), 3.5 (0.14)</p> | 440G-A27011 |
|  | Fully flex actuator |  <p>Dimensions: 6.8 (0.27), 18 (0.71), 52 (2.05), 40 (1.57), 31 (1.22), Adjusting screws, 2 x M3, 13 (0.51), 19 (0.75), 51 (2.01), 8 (0.31), 4 x Ø5.5 (0.22), 20 (0.79)</p> | 440G-A27143 |
|  | Catch and Retainer Kit |  <p>Dimensions: 52 (2.05), 29 (1.14), 4 (0.16), 18 (0.71), 7.25 (0.29), 52 (20.5), 40 (1.57), 14.5 (0.57), 1.5 (0.06), 25.5 (1.0), 11.2 (0.44)</p> | 440K-A11094 |

* See page 3-8 for Switch Compatibility table.

3-Interlock Switches

Product Selection

| Type | Actuator Type | Trapped Key Condition | Cat. No. |
|---------------------------------|---------------|---|----------------|
| Single key | Standard | Key trapped to release actuator | 440T-MSSLE10* |
| | Flexible | | 440T-MSSLE11* |
| | Flat | | 440T-MSSLE12* |
| Dual key | Standard | Primary key trapped, secondary key free to release actuator | 440T-MDSLE10*⊗ |
| | Flexible | | 440T-MDSLE11*⊗ |
| | Flat | | 440T-MDSLE12*⊗ |
| | Standard | Both keys trapped to release actuator | 440T-MDSLE20** |
| | Flexible | | 440T-MDSLE22** |
| | Flat | | 440T-MDSLE23** |
| Dual with secondary ejector key | Standard | Primary key trapped, secondary key free to release actuator | 440T-MDSLJ10*⊗ |
| | Flexible | | 440T-MDSLJ11*⊗ |
| | Flat | | 440T-MDSLJ12*⊗ |

* Substitute the desired primary code for this symbol (key not included). See 3-107 for code selection.
 ⊗ Substitute the desired secondary code for this symbol (key included). See 3-107 for code selection.

Accessories

| Description | Additional Information | Cat. No. |
|---|------------------------|---------------|
| Stainless steel key | 3-140 | 440T-AKEYE10⊗ |
| Stainless steel ejector key | | 440T-AKEYE13⊗ |
| Stainless steel replacement code barrel with dust cap | | 440T-ASCBE14* |
| Stainless steel weatherproof replacement dust cap | | 440T-ASFC10⊗ |
| GD2 standard actuator | — | 440G-A27011 |
| GD2 flat actuator | — | 440K-A11112 |
| Fully flex actuator | — | 440G-A27143 |

* Substitute the desired primary code for this symbol (key not included). See 3-107 for code selection.
 ⊗ Substitute the desired code for this symbol. See 3-107 for code selection.

Approximate Dimensions [mm (in.)]

Dimensions are not intended to be used for installation purposes.

Single Key Slamlock

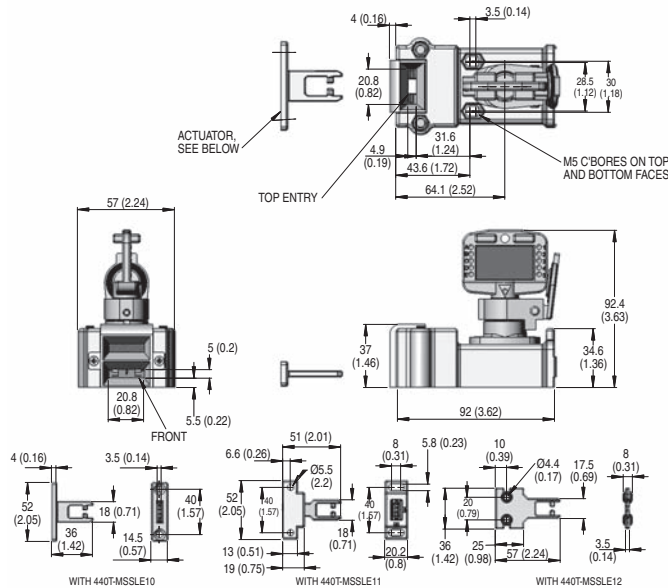

Dual Key Slamlock

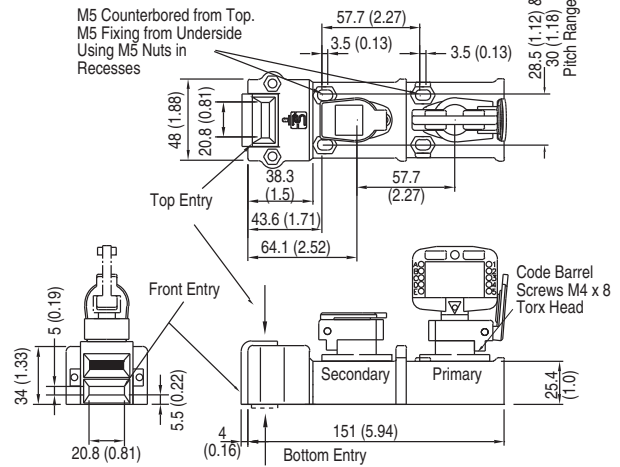

Flat Actuator

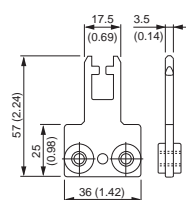

Flexible/Adjustable Actuator

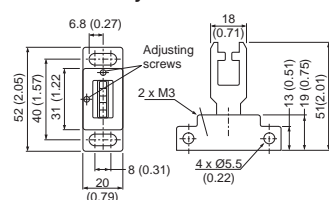

Standard Actuator

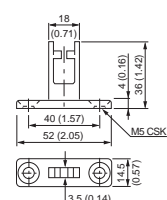

Approximate Dimensions [mm (in.)] (continued)





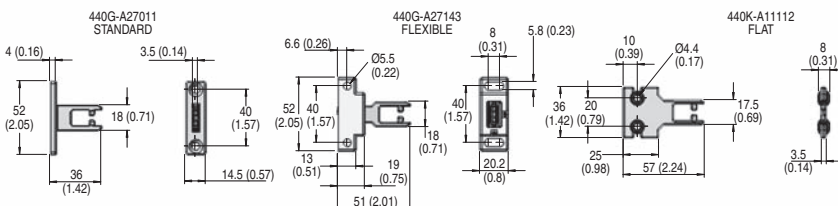
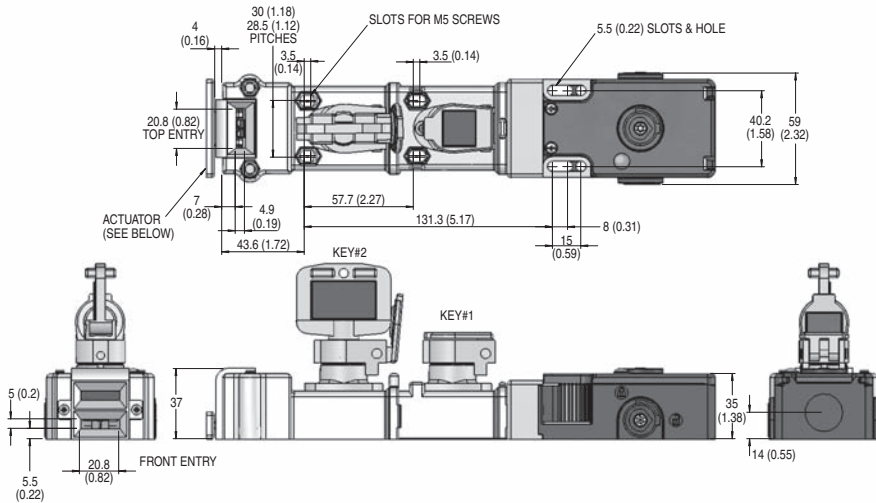
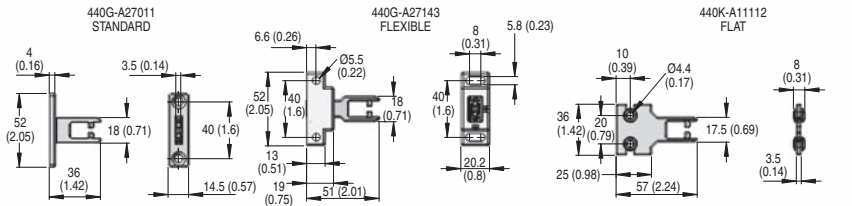
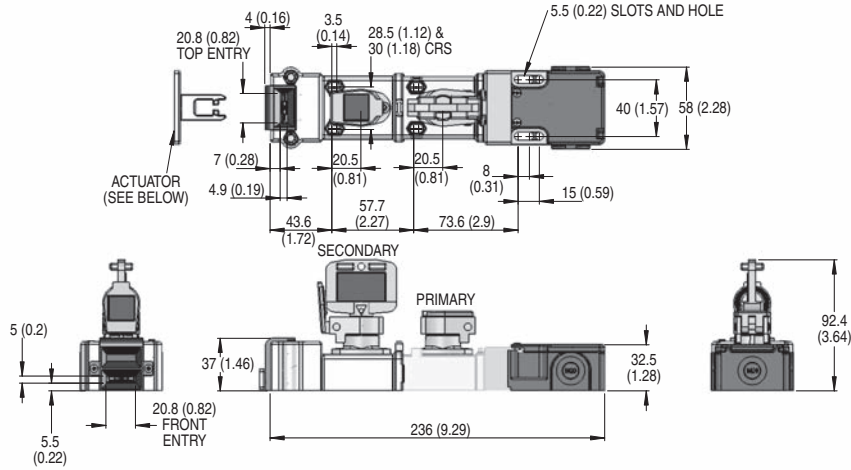

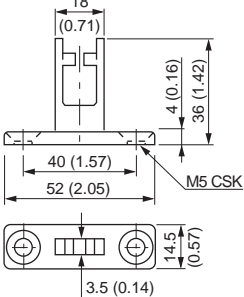

Dimensions are not intended to be used for installation purposes.

Dual Key Slamlock

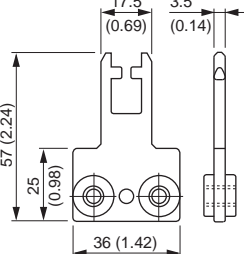

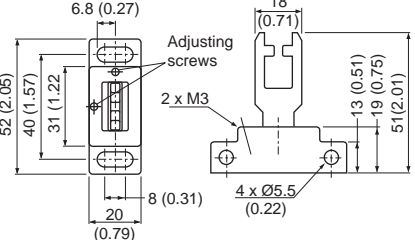
3-Trapped Key
 Switches

Accessories

| | Description | Approximate Dimensions [mm (in.)] | Cat. No. |
|---|---|---|---------------|
|  | GD2 standard actuator |  | 440G-A27011 |
|  | GD2 flat actuator |  | 440K-A11112 |
|  | Fully flex actuator |  | 440G-A27143 |
|  | Stainless steel key | page 3-140 | 440T-AKEYE10⊗ |
|  | Stainless steel replacement code barrel with dust cap | | 440T-ASCBE14* |
|  | Stainless steel weatherproof replacement dust cap | | 440T-ASFC10⊗ |

* Substitute the desired primary code for this symbol (key not included). See 3-107 for code selection.
 ⊗ Substitute the desired code for this symbol. See 3-107 for code selection.

Typical Applications

Actuator out, key trapped, safety contacts open, auxiliary contact closed.

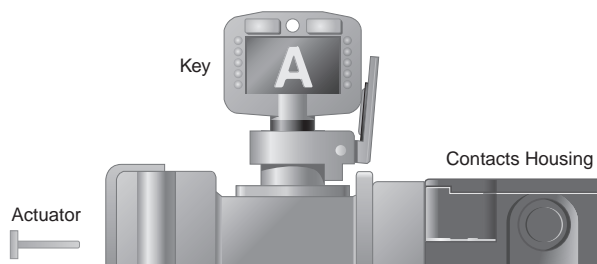

Locking force = 2000 N (450 lb)

3-Trapped Key
Switches



440J-A01N
 Bracket
 Shown with
 GD2 Actuator

With two additional screws, the right angle bracket can be mounted to the 440J enabling switch for horizontal mounting. An actuator can also be mounted for vertical use without the 440J-A01N bracket.



Shown with
 440G-A27011
 GD2 Actuator

Horizontal Mounting



Shown with
 440K-A11095
 Standard Actuator

Vertical Mounting



Horizontal Mount
 with MT-GD2



Vertical Mount
 with Trojan

In some applications, additional contacts are needed when the enabling switch is used. Two additional accessories are used to allow the enabling switch to interact with two interlocks.

Cat. No. 440J-A03N accessory mounts to the enabling switch base plate. This accessory has two sets of holes to accommodate either two standard or two GD2 actuators. This arrangement is used in conjunction with Cat. No. 440K-A04N accessory.

The mounting plate (Cat. No. 440J-A02N) has multiple pre-drilled and tapped holes to facilitate mounting of a single 440K-MT (MT-GD2) or 440K-T (Trojan) interlock. Four additional through-holes at the corners allow mounting of the plate to a flat surface.

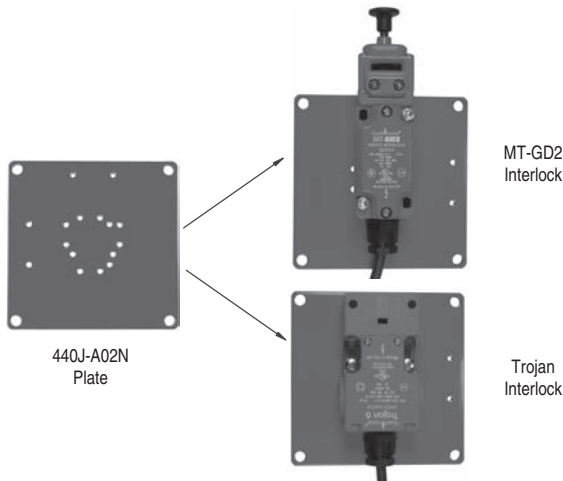

440J-A02N
 Plate

MT-GD2
 Interlock

Trojan
 Interlock



440J-A03N



Enabling Switch mounted on
 440J-A03N, shown with
 two standard actuators

The U-shaped 440J-A04N can accommodate two interlocks: either 440K-MT or 440K-T. Using the 440J-A03N plate with dual actuators, a total of eight contacts, four in each switch, can be made available for the safety and control system.

The MT-GD2 with the manual latch release should be used for vertical mounting. The Trojan should only be used with horizontal actuator mounting. To use the 440K-T (Trojan 6 or T15), the head must be rotated 180°. The Trojan GD2 models cannot be used with the 440J-A02N as its head cannot be rotated.

The recommended method for single-switch mounting is to use the 440K-MT (MT-GD2) with the latch release. The latch holds the contacts closed when the enabling switch is bumped or rattled. An alternative is to use the 440K-T (Trojan 6 or T15) with a vertical mounting. The holding force of these interlocks is enough to keep the contacts closed under minor bumps and rattles.