



# FPF3040 IntelliMAX™ 18 V-Rated Dual Input Single Output Power-Source-Selector Switch

## Features

- Dual-Input, Single-Output Load Switch
- Input Supply Operating Range:
  - 4~10.5 V at  $V_{IN}$
  - 4~6.5 V at  $V_{BUS}$
- Typical  $R_{ON}$ :
  - 95 m $\Omega$  at  $V_{IN}=5$  V
  - 70 m $\Omega$  at  $V_{BUS}=5$  V
- Bi-Directional Switch for  $V_{IN}$  and  $V_{BUS}$
- Slew Rate Controlled:
  - 50  $\mu$ s at  $V_{IN}$  for  $< 4.7 \mu$ F  $C_{OUT}$
  - 90  $\mu$ s at  $V_{BUS}$  for  $< 4.7 \mu$ F  $C_{OUT}$
- Maximum  $I_{SW}$ : 2 A Per Channel
- Break-Before-Make Transition
- Under-Voltage Lockout (UVLO)
- Over-Voltage Lockout (OVLO)
- Thermal Shutdown
- Logic CMOS IO Meets JESD76 Standard for GPIO Interface and Related Power Supply Requirements
- ESD Protected:
  - Human Body Model:  $>3$  kV
  - Charged Device Model:  $>1.5$  kV
  - IEC 61000-4-2 Air Discharge:  $>15$  kV
  - IEC61000-4-2 Contact Discharge:  $>8$  kV

## Description

The FPF3040 is a 18 V-rated Dual-Input Single-Output (DISO) load switch consisting of two channels of slew-rate-controlled, low-on-resistance, N-channel MOSFET switches with protection features. The slew-rate-controlled turn-on characteristic prevents inrush current and the resulting excessive voltage droop on the input power rails. The input voltage range operates from 4 V to 6.5 V at  $V_{BUS}$  and from 4 V to 10.5 V at  $V_{IN}$  to align with the needs of low-voltage portable device power rails.

$V_{IN}$  and  $V_{BUS}$  have the over-voltage protection functionality of typical 12 V and 7.5 V, respectively, to avoid unwanted damage to system.

$V_{IN}$  and  $V_{BUS}$  bi-directional switching allows reverse current from  $V_{OUT}$  to  $V_{IN}$  or  $V_{BUS}$  for On-The-Go, (OTG) Mode. The switching is controlled by logic input EN and  $V_{IN\_SEL}$  is capable of interfacing directly with low-voltage control signal General-Purpose Input / Output (GPIO).

FPF3040 is available in 1.8 mm x 2.0 mm Wafer-Level Chip-Scale Package (WLCSP), 16-bump, 0.4 mm pitch.

## Applications

- Input Power Selection Block Supporting USB and Wireless Charging
- Smartphone / Tablet PC

## Ordering Information

Part Number	Top Mark	Channel	Typical $R_{ON}$ per Channel at $5V_{IN}$	Rise Time ( $t_R$ )	Package
FPF3040UCX	QY	DISO	95 m $\Omega$ for $V_{IN}$	50 $\mu$ s for $V_{IN}$	1.8 mm x 2.0 mm Wafer-Level Chip-Scale Package (WLCSP), 16-Bump, 0.4 mm Pitch
			70 m $\Omega$ for $V_{BUS}$	90 $\mu$ s for $V_{BUS}$	

Application Diagram

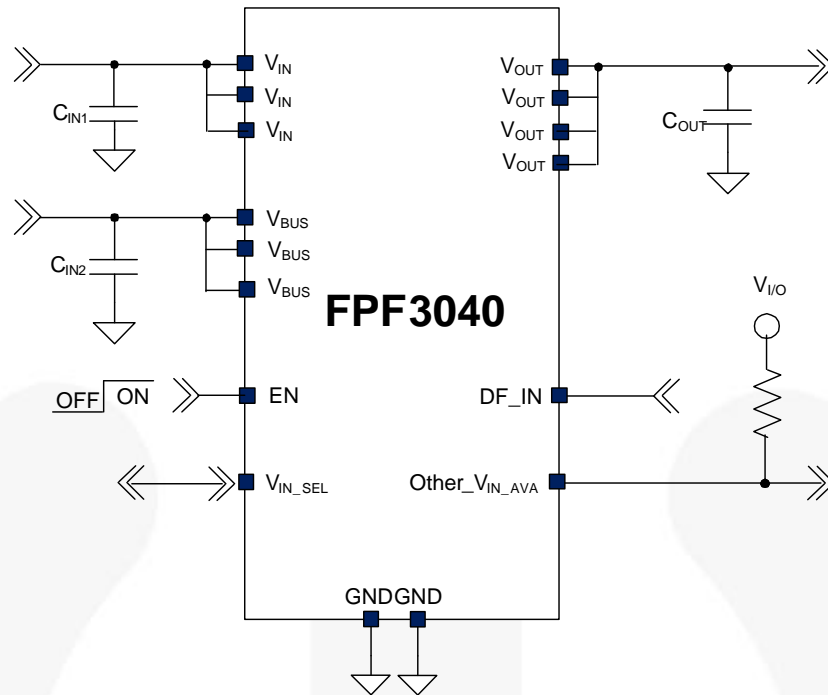

Figure 1. Typical Application

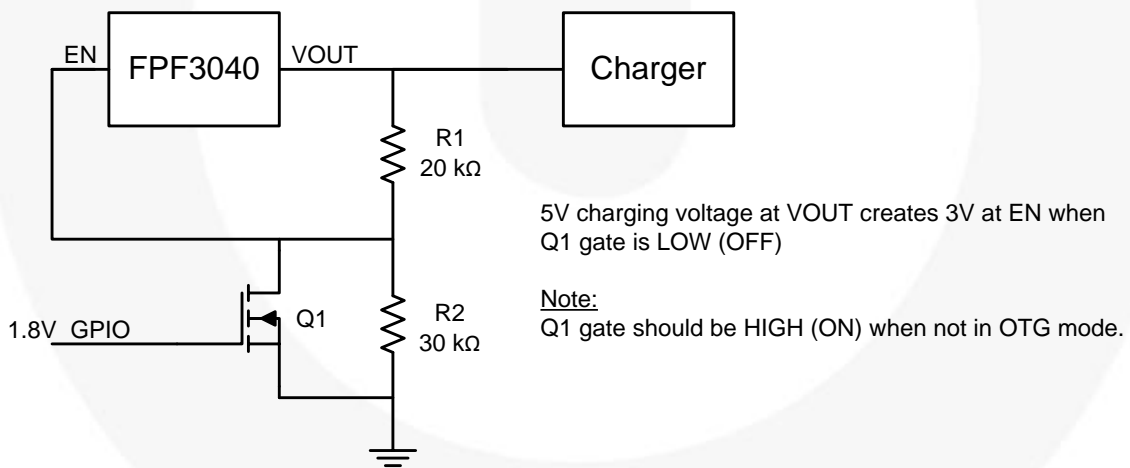

Figure 2. Example Circuit for OTG Operation with Low-Voltage GPIO

Block Diagram

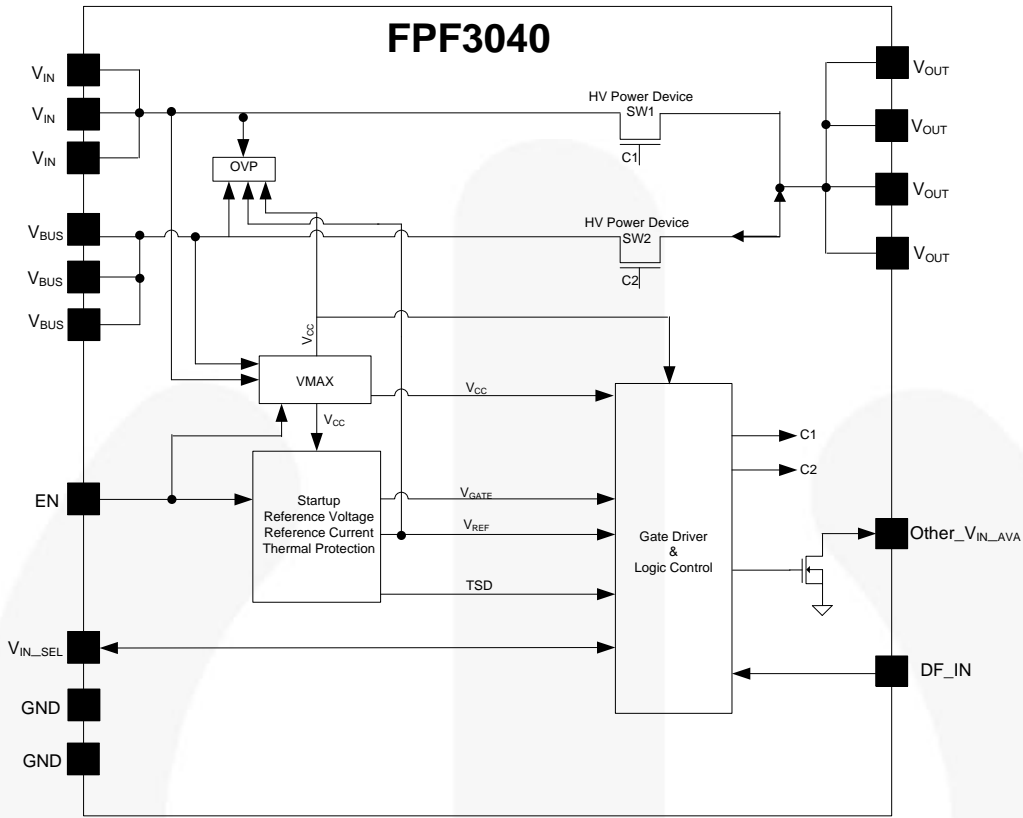

Figure 3. Functional Block Diagram

## Pin Configuration

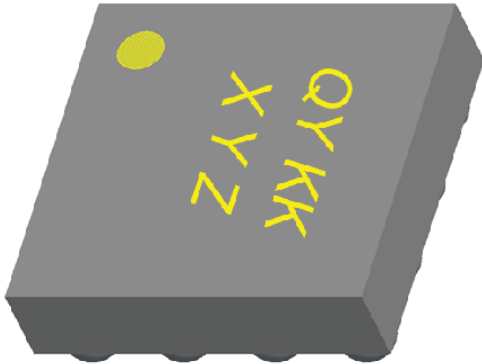

Figure 4. Pin Assignment (Top View)

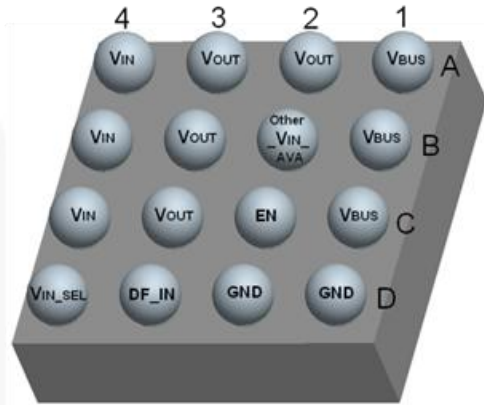

Figure 5. Pin Assignment (Bottom View)

## Pin Description

Pin #	Name	Input / Output	Description
A1, B1, C1	V <sub>BUS</sub>	Input / Output	<b>V<sub>BUS</sub> at USB:</b> Power input / output. bi-directional switch when V <sub>IN_SEL</sub> = LOW.
A4, B4, C4	V <sub>IN</sub>	Input / Output	<b>V<sub>IN</sub> Supply Input:</b> Power input / output. bi-directional switch when V <sub>IN_SEL</sub> = HIGH.
A2, A3, B3, C3	V <sub>OUT</sub>	Input / Output	<b>Switch Output:</b> Power input / output.
C2	EN	Input	<b>Enable:</b> Active HIGH. EN voltage ≥ 2.5 V can power internal circuit when V <sub>IN</sub> and V <sub>BUS</sub> are absent. 1 MΩ pull-down resistor is included.
D4	V <sub>IN_SEL</sub>	Input / Output	<b>Supply Selector &amp; Status:</b> Input power source selection input and status output. This signal is ignored during EN=LOW. Selector input during EN=HIGH: HIGH = switch V <sub>IN</sub> to V <sub>OUT</sub> / LOW = switch V <sub>BUS</sub> to V <sub>OUT</sub> . Status output during EN=LOW: HIGH = V <sub>IN</sub> is used for V <sub>OUT</sub> / LOW = V <sub>BUS</sub> is used for V <sub>OUT</sub> .
D3	DF_IN	Input	<b>Default Supply Selector during EN=LOW:</b> Input. Floating = V <sub>BUS</sub> connects to V <sub>OUT</sub> . LOW means V <sub>IN</sub> connects to V <sub>OUT</sub> . This signal is ignored during EN=HIGH. 1 μA pull-up current source is included.
B2	Other_V <sub>IN_AVA</sub>	Output	<b>Other Supply Input Status:</b> Open-drain output. HI-Z = both V <sub>IN</sub> and V <sub>BUS</sub> are valid. LOW = the other power source is not valid.
D1, D2	GND		<b>Ground</b>

**Table 1. Truth Table**

EN	V <sub>IN</sub> >UVLO	V <sub>BUS</sub> >UVLO	V <sub>IN_SEL</sub>	DF_IN	Other_V <sub>IN_AVA</sub>	V <sub>OUT</sub>	Comment
HIGH	X	X	LOW	X	HI-Z if V <sub>IN</sub> & V <sub>BUS</sub> >UVLO LOW if V <sub>IN</sub> or V <sub>BUS</sub> <UVLO	V <sub>BUS</sub>	V <sub>OUT</sub> is selected by V <sub>IN_SEL</sub> Bi-directional channel
HIGH	X	X	HIGH	X	HI-Z if V <sub>IN</sub> & V <sub>BUS</sub> >UVLO LOW if V <sub>IN</sub> or V <sub>BUS</sub> <UVLO	V <sub>IN</sub>	
LOW	YES	NO	HIGH	X	LOW	V <sub>IN</sub>	Automatic selection to valid input V <sub>IN_SEL</sub> is output.
LOW	NO	YES	LOW	X	LOW	V <sub>BUS</sub>	
LOW	YES	YES	LOW	Floating	HIGH	V <sub>BUS</sub>	V <sub>OUT</sub> is selected by DF_IN V <sub>IN_SEL</sub> is output.
LOW	YES	YES	HIGH	LOW	HIGH	V <sub>IN</sub>	
LOW	NO	NO	X	X	LOW	Floating	OFF

**Notes:**

- Internal pull-down at EN.
- 1  $\mu$ A pull-up current source at DF\_IN.

**Absolute Maximum Ratings**

Stresses exceeding the Absolute Maximum Ratings may damage the device. The device may not function or be operable above the recommended operating conditions and stressing the parts to these levels is not recommended. In addition, extended exposure to stresses above the recommended operating conditions may affect device reliability. The absolute maximum ratings are stress ratings only.

Symbol	Parameters		Min.	Max.	Unit	
V <sub>PIN</sub>	V <sub>IN</sub> , V <sub>BUS</sub> to GND	Continuous	-1.4	18	V	
		Pulsed, 100 ms Maximum Non-Repetitive	-2.0			
	V <sub>OUT</sub> to GND <sup>(3)</sup>		-0.3	16.0		
	EN, DF_IN, V <sub>IN_SEL</sub> , Other_V <sub>IN_AVA</sub> to GND		-0.3	6.0		
I <sub>SW</sub>	Maximum Continuous Switch Current per Channel			2	A	
t <sub>PD</sub>	Total Power Dissipation at T <sub>A</sub> =25°C			2.25	W	
T <sub>J</sub>	Operating Junction Temperature		-40	+150	°C	
T <sub>STG</sub>	Storage Junction Temperature		-65	+150	°C	
θ <sub>JA</sub>	Thermal Resistance, Junction-to-Ambient (1in. Square Pad of 2 oz. Copper)			55 <sup>(4)</sup>	°C/W	
ESD	Electrostatic Discharge Capability	Human Body Model, JESD22-A114	3		kV	
		Charged Device Model, JESD22-C101	1.5			
		IEC61000-4-2 System Level <sup>(5)</sup>	Air Discharge (V <sub>IN</sub> , V <sub>BUS</sub> to GND)	15		
			Contact Discharge (V <sub>IN</sub> , V <sub>BUS</sub> to GND)	8		

**Notes:**

- If external voltage of more than 10.5 V is applied to V<sub>OUT</sub>, the slew rate should be less than 1 V/ms from 10.5 V.
- Measured using 2S2P JEDEC standard PCB.
- System level ESD can be guaranteed by design.

**Recommended Operating Conditions**

The Recommended Operating Conditions table defines the conditions for actual device operation. Recommended operating conditions are specified to ensure optimal performance to the datasheet specifications. Fairchild does not recommend exceeding them or designing to Absolute Maximum Ratings.

Symbol	Parameters	Min.	Max.	Unit
V <sub>PIN</sub>	V <sub>IN</sub>	4.0	10.5	V
	V <sub>BUS</sub>	4.0	6.5	
T <sub>A</sub>	Ambient Operating Temperature	-40	+85	°C

## Electrical Characteristics

$V_{IN}$ =4 to 10.5 V,  $V_{BUS}$ =4 to 6.5 V,  $T_A$ =-40 to 85°C unless otherwise noted. Typical values are at  $V_{IN}=V_{BUS}=5$  V, EN=HIGH and  $T_A=25^\circ\text{C}$  unless otherwise noted.

Symbol	Parameters	Condition	Min.	Typ.	Max.	Unit
<b>Basic Operation</b>						
$V_{IN}$	Input Voltage		4.0		10.5	V
$V_{BUS}$			4.0		6.5	V
$I_Q$	Quiescent Current	$I_{OUT}=0$ mA, EN=HIGH, $V_{IN}$ or $V_{BUS}=5$ V		55	120	$\mu\text{A}$
		$I_{OUT}=0$ mA, EN=5 V, $V_{IN}$ and $V_{BUS}=\text{GND}$		33	70	$\mu\text{A}$
$R_{ON}$	On Resistance for $V_{IN}$	$V_{IN}=8$ V, $I_{OUT}=200$ mA, $T_A=25^\circ\text{C}$		95		m $\Omega$
		$V_{IN}=5$ V, $I_{OUT}=200$ mA, $T_A=25^\circ\text{C}$		95	150	
		$V_{IN}=5$ V, $I_{OUT}=200$ mA, $T_A=25^\circ\text{C}$ to $85^\circ\text{C}^{(6)}$			200	
	On Resistance for $V_{BUS}$	$V_{BUS}=6$ V, $I_{OUT}=200$ mA, $T_A=25^\circ\text{C}$		70		m $\Omega$
		$V_{BUS}=5$ V, $I_{OUT}=200$ mA, $T_A=25^\circ\text{C}$		70	100	
		$V_{BUS}=5$ V, $I_{OUT}=200$ mA, $T_A=25^\circ\text{C}$ to $85^\circ\text{C}^{(6)}$			140	
$V_{IH}$	Input Logic High Voltage	$V_{IN}=4$ V~10.5 V, $V_{BUS}=4$ V ~ 6.5 V	1.15			V
$V_{IL}$	Input Logic Low Voltage	$V_{IN}=4$ V~10.5 V, $V_{BUS}=4$ V ~ 6.5 V			0.52	V
$V_{EN(OTG)}$	EN Voltage in OTG Mode <sup>(6)</sup>	$V_{IN}$ & $V_{BUS}=\text{Float}$ or $V_{IN}$ & $V_{BUS} < V_{UVLO}$	2.5			V
$R_{EN\_PD}$	Pull-Down Resistance at EN		707	1000	1360	k $\Omega$
<b>Protection</b>						
$V_{UVLO}$	Under-Voltage Lockout Threshold	$V_{IN}$ or $V_{BUS}$ Rising	3.05	3.50	4.00	V
		$V_{IN}$ or $V_{BUS}$ Falling	2.55	3.00	3.55	V
$V_{UVHYS}$	Under-Voltage Lockout Hysteresis			0.5		V
$V_{OVLO}$	Over-Voltage Lockout Threshold	$V_{IN}$ Rising Threshold	10.85	12.00	13.45	V
		$V_{IN}$ Falling Threshold		11.5		V
		$V_{BUS}$ Rising Threshold	6.52	7.50	8.32	V
		$V_{BUS}$ Falling Threshold		7		V
$V_{OVHYS}$	Over-Voltage Lockout Hysteresis	$V_{IN}$		0.5		V
		$V_{BUS}$		0.5		V
$T_{SDN}$	Thermal Shutdown Threshold			150		$^\circ\text{C}$
$T_{SDNHYS}$	Thermal Shutdown Hysteresis			20		$^\circ\text{C}$
<b>Reverse Current Blocking</b>						
$I_{RCB}$	$V_{IN}$ or $V_{BUS}$ Current During RCB	$V_{OUT}=8$ V, $V_{IN}$ or $V_{BUS}=\text{GND}$			30	$\mu\text{A}$
<b>Dynamic Characteristics</b>						
$t_R$	$V_{OUT}$ Rise Time, $V_{BUS}^{(6,7)}$	$V_{IN}=V_{BUS}=5$ V, $R_L=150$ $\Omega$ , $C_L=4.7$ $\mu\text{F}$ , $T_A=25^\circ\text{C}$		90		$\mu\text{s}$
	$V_{OUT}$ Rise Time, $V_{IN}^{(6,7)}$			50		
$t_F$	$V_{OUT}$ Fall Time <sup>(6,7)</sup>			1.4		ms
$t_{TRAN}$	Transition Delay <sup>(6,7)</sup>			50	100	ms
$t_{SD}$	Selection Delay <sup>(6,7)</sup>				50	$\mu\text{s}$

### Notes:

- This parameter is guaranteed by characterization and/or design; not production tested.
- $t_{SD}/t_{TRAN}/t_R/t_F$  are defined in Figure 6.

Timing Diagram

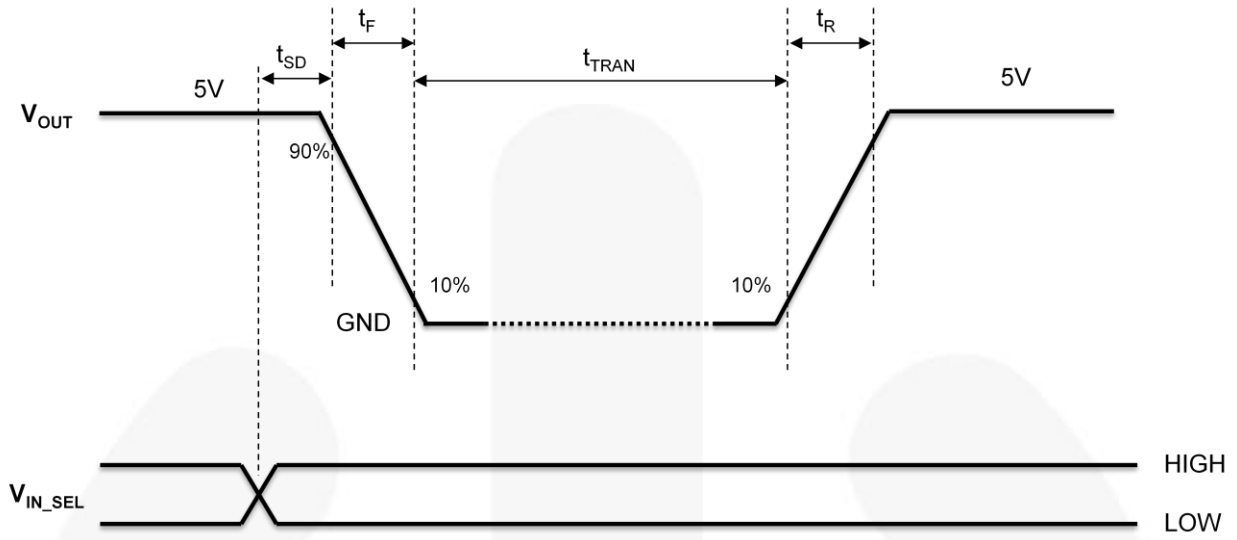

Figure 6. Transition Delay ( $V_{IN}=V_{BUS}=5\text{ V}$ )

## Typical Characteristics

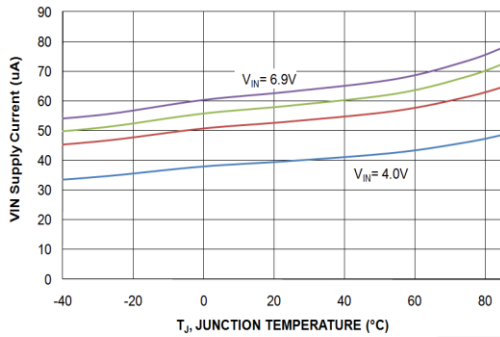

Figure 7.  $V_{IN}$  Quiescent Current ( $I_q$ ) vs. Temperature

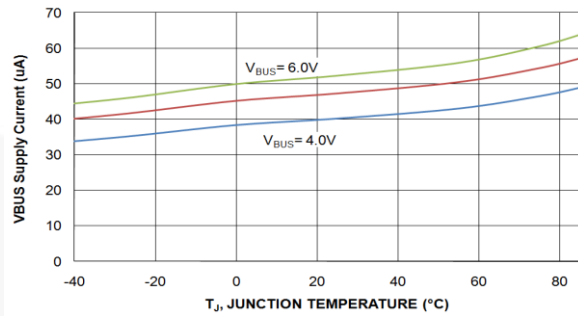

Figure 8.  $V_{BUS}$  Quiescent Current ( $I_q$ ) vs. Temperature

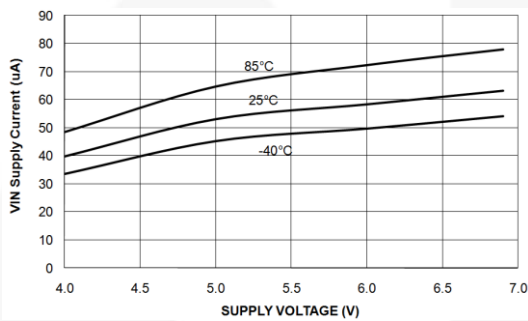

Figure 9.  $V_{IN}$  Quiescent Current vs. Supply Voltage

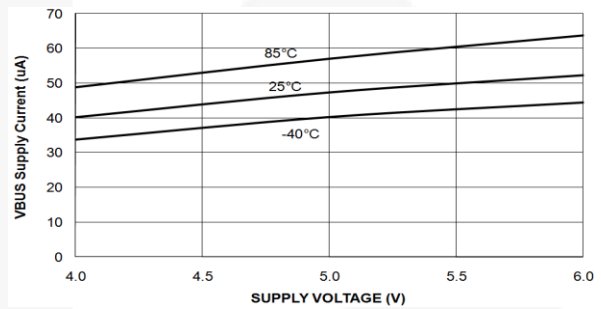

Figure 10.  $V_{BUS}$  Quiescent Current vs. Supply Voltage

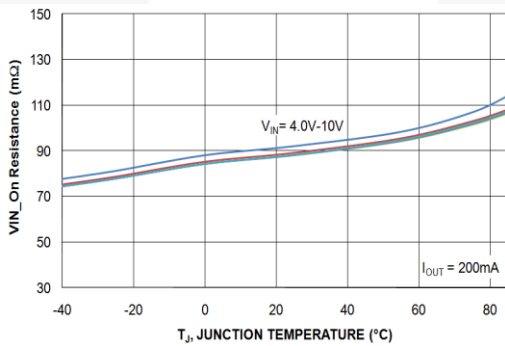

Figure 11.  $V_{IN}$  On Resistance ( $m\Omega$ ) vs. Temperature

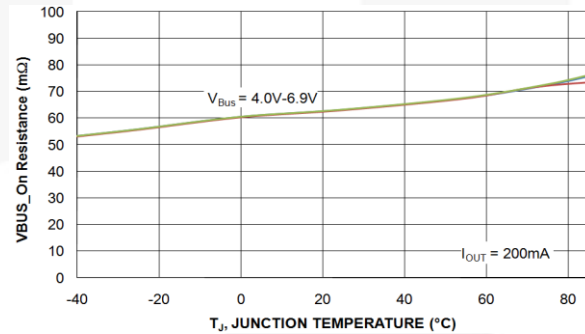

Figure 12.  $V_{BUS}$  On Resistance ( $m\Omega$ ) vs. Temperature

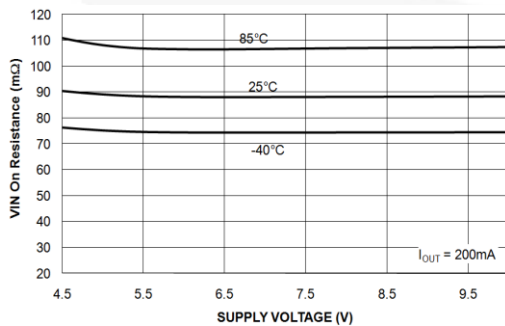

Figure 13.  $V_{IN}$  On Resistance ( $m\Omega$ ) vs. Supply Voltage

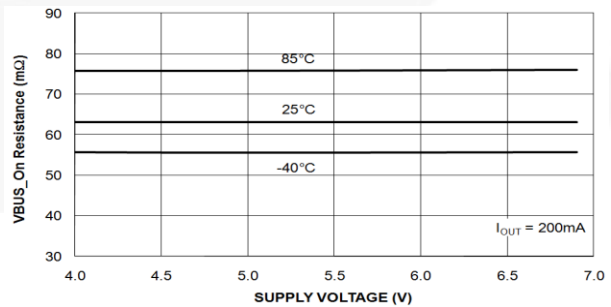

Figure 14.  $V_{BUS}$  On Resistance ( $m\Omega$ ) vs. Supply Voltage

Typical Characteristics (Continued)

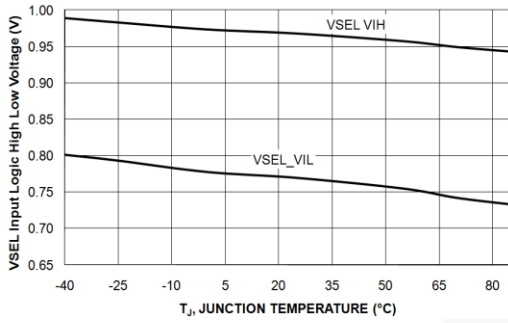

Figure 15. V<sub>IN\_SEL</sub> Input Logic High & Low Voltage vs. Temperature

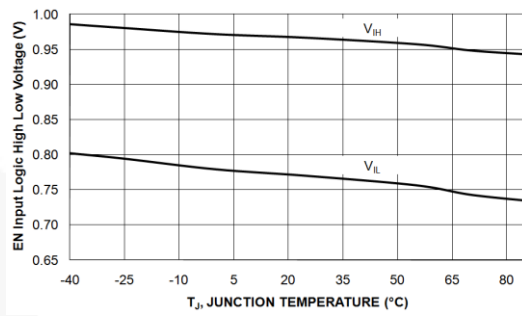

Figure 16. EN Input Logic High & Low Voltage vs. Temperature

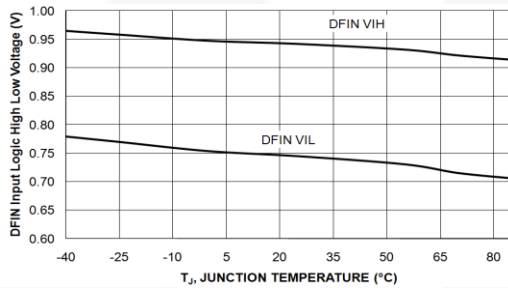

Figure 17. DF<sub>IN</sub> Logic High & Low Voltage vs. Temperature

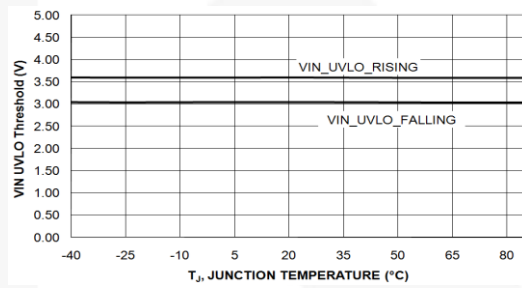

Figure 18. V<sub>IN\_UVLO</sub> vs. Temperature

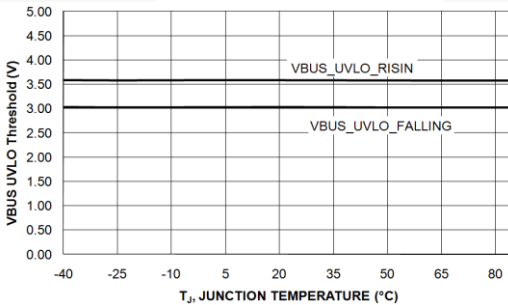

Figure 19. V<sub>BUS\_UVLO</sub> vs. Temperature

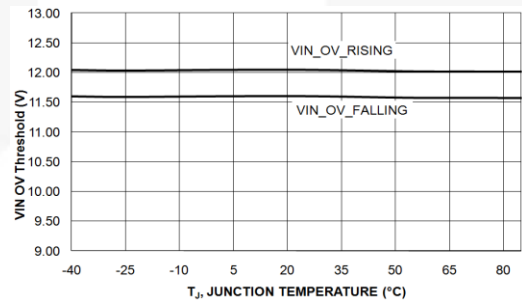

Figure 20. V<sub>IN\_OVLO</sub> vs. Temperature

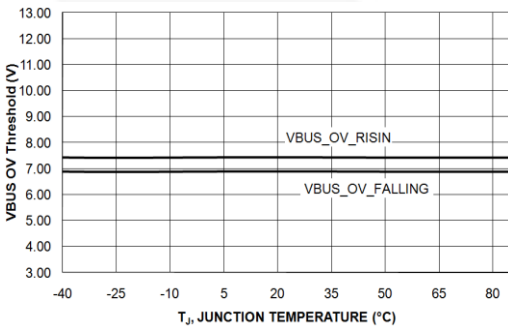

Figure 21. V<sub>BUS\_OVLO</sub> vs. Temperature

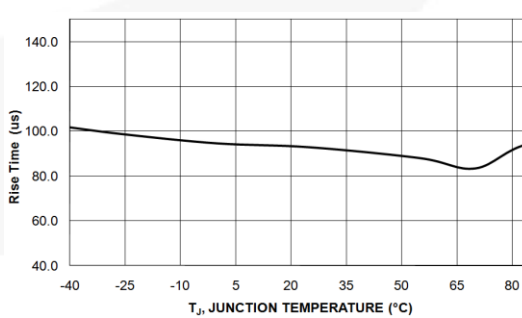
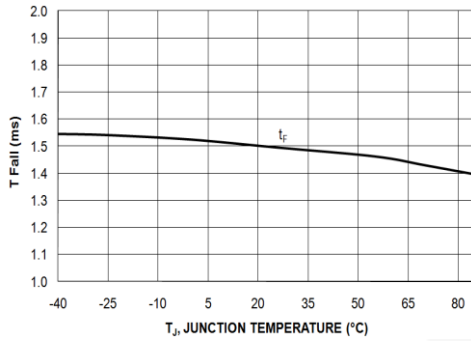
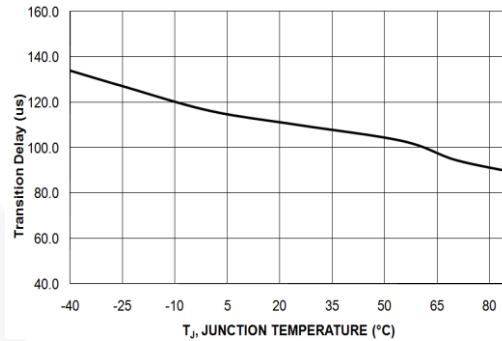

Figure 22. V<sub>OUT</sub> t<sub>R</sub> vs. Temperature

## Typical Characteristics (Continued)



**Figure 23.  $V_{OUT}$   $t_F$  vs. Temperature**



**Figure 24.  $t_{TRAN}$  vs. Temperature**

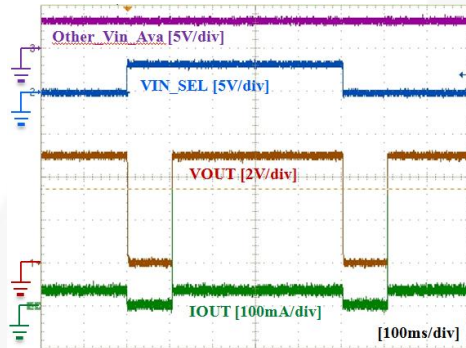

**Figure 25. Power Source Transition ( $V_{IN}=V_{BUS}=5$  V,  $EN=HIGH$ ,  $V_{IN\_SEL}=LOW \rightarrow HIGH \rightarrow LOW$ ,  $C_{OUT}=4.7$   $\mu F$ ,  $R_L=150$   $\Omega$ )**

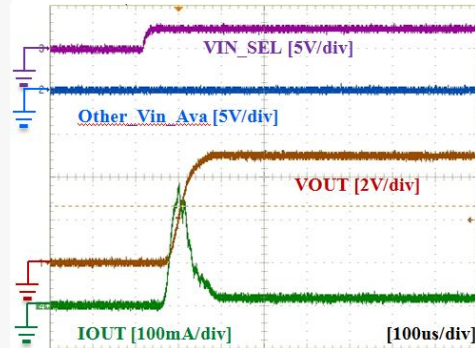

**Figure 26.  $V_{IN}$  On Response ( $V_{IN}=GND \rightarrow 5$  V,  $V_{BUS}=EN=GND$ ,  $C_{OUT}=4.7$   $\mu F$ ,  $R_L=150$   $\Omega$ )**

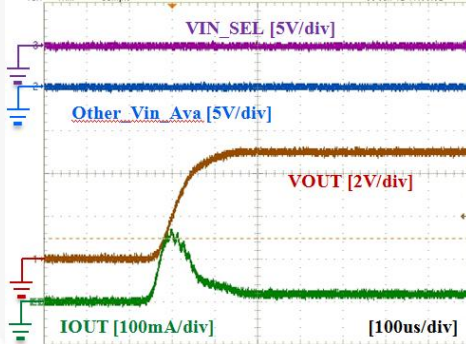

**Figure 27.  $V_{BUS}$  On Response ( $V_{BUS}=GND \rightarrow 5$  V,  $V_{IN}=EN=GND$ ,  $C_{OUT}=4.7$   $\mu F$ ,  $R_L=150$   $\Omega$ )**

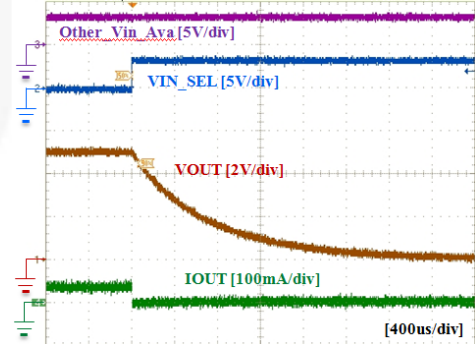

**Figure 28. Off Response ( $V_{IN}=V_{BUS}=5$  V,  $EN=HIGH$ ,  $V_{IN\_SEL}=LO \rightarrow HIGH$  or  $HIGH \rightarrow LOW$ ,  $C_{OUT}=4.7$   $\mu F$ ,  $R_L=150$   $\Omega$ )**

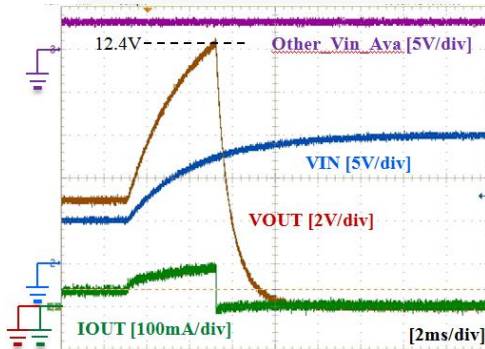

**Figure 29.  $V_{IN}$  Over-Voltage Protection Response ( $V_{IN}=5$  V  $\rightarrow 15$  V,  $V_{BUS}=5$  V,  $EN=V_{IN\_SEL}=HIGH$ ,  $C_{OUT}=4.7$   $\mu F$ ,  $R_L=150$   $\Omega$ )**

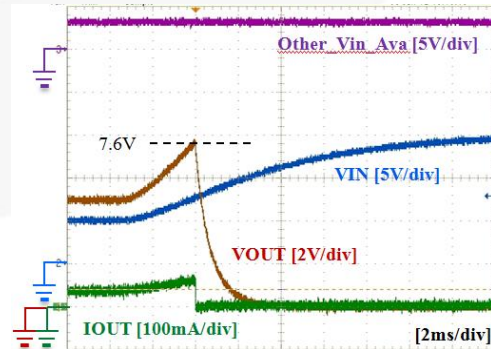

**Figure 30.  $V_{BUS}$  Over-Voltage Protection Response ( $V_{BUS}=5$  V  $\rightarrow 15$  V,  $V_{IN}=5$  V,  $EN=HIGH$ ,  $V_{IN\_SEL}=LOW$ ,  $C_{OUT}=4.7$   $\mu F$ ,  $R_L=150$   $\Omega$ )**

## Operation and Application Information

The FPF3040 is a 18 V, 2 A-rated, Dual-Input Single-Output (DISO) load switch with slew-rate-controlled, low-on-resistance, based-on-N-channel MOSFET. The input operating range is from 4 V to 6.5 V at  $V_{BUS}$  and from 4 V to 10.5 V at  $V_{IN}$ . The internal circuitry is powered from the highest voltage source among  $V_{IN}$ ,  $V_{BUS}$ , and  $V_{EN}$ .

### Input Power Source Selection

Input power source can be selected by  $V_{IN\_SEL}$  and  $DF\_IN$ , respectively, depending on EN state. When EN is HIGH, the input source is selected by  $V_{IN\_SEL}$  regardless of  $DF\_IN$ . If  $V_{IN\_SEL}$  is LOW,  $V_{BUS}$  is selected. If  $V_{IN\_SEL}$  is HIGH,  $V_{IN}$  is selected.

**Table 2. Input Power Selection by  $V_{IN\_SEL}$**

EN	$V_{IN}>UVLO$	$V_{BUS}>UVLO$	$V_{IN\_SEL}$	$DF\_IN$	$V_{OUT}$
HIGH	X	X	LOW	X	$V_{BUS}$
HIGH	X	X	HIGH	X	$V_{IN}$

When EN is LOW, the input source is selected by  $DF\_IN$  and the number of valid input sources. If only one input source is valid, or more than UVLO, the source is selected automatically, regardless of  $DF\_IN$ , to make a charging path in case the battery is depleted. If both  $V_{BUS}$  and  $V_{IN}$  have valid input sources, the input source is selected by  $DF\_IN$ . If  $DF\_IN$  is LOW,  $V_{IN}$  is selected. If  $DF\_IN$  is HIGH or floating,  $V_{BUS}$  is selected.  $DF\_IN$  is biased HIGH with an internal 1  $\mu$ A pull-up current source.

**Table 3. Input Power Selection by  $DF\_IN$**

EN	$V_{IN}>UVLO$	$V_{BUS}>UVLO$	$V_{IN\_SEL}$	$DF\_IN$	$V_{OUT}$
LOW	YES	NO	HIGH	X	$V_{IN}$
LOW	NO	YES	LOW	X	$V_{BUS}$
LOW	YES	YES	LOW	Floating	$V_{BUS}$
LOW	YES	YES	HIGH	LOW	$V_{IN}$
LOW	NO	NO	X	X	Floating

$V_{IN\_SEL}$  can be the status output to indicate which input power source is used during EN is LOW. If  $V_{IN}$  is used,  $V_{IN\_SEL}$  shows high. If  $V_{BUS}$  is used,  $V_{IN\_SEL}$  shows LOW. The voltage level of HIGH signal is 5.3 V if any one of

$V_{IN}$ ,  $V_{BUS}$  or EN is higher than 5.3 V. The signal is highest voltage among  $V_{IN}$ ,  $V_{BUS}$ , and  $V_{EN}$  if none of them is higher than 5.3 V.

### EN Voltage for Control Logic Power Supply

Internal control logic is powered from the highest voltage among  $V_{IN}$ ,  $V_{BUS}$ , and  $V_{EN}$ . If valid  $V_{IN}$  or  $V_{BUS}$  higher than UVLO is applied, ON/OFF control by EN should be accomplished with  $V_{IH}/V_{IL}$ . If EN powers the internal control block without valid  $V_{IN}$  and  $V_{BUS}$ , more than 2.5 V is required on the EN pin to operate properly.

### Over-Voltage Protection (OVP)

FPF3040 has over-voltage protection at both  $V_{IN}$  and  $V_{BUS}$ . If  $V_{IN}$  or  $V_{BUS}$  is higher than 12 V or 7.5 V, respectively, the power switch is off until input voltage is lower than the over-voltage trip level by hysteresis voltage of 0.5 V.

### Reverse Power Supply for OTG

FPF3040 has a bi-directional switch so reverse power is allowed for On-The-Go (OTG) operation. Even if both  $V_{IN}$  and  $V_{BUS}$  are not available, reverse power can be also supported if internal control circuitry is powered by EN.

### Reverse-Current Blocking

FPF3040 supports reverse-current blocking during EN LOW and an unselected channel.

### Thermal Shutdown

During FPF3040 thermal shutdown, the power switch is turned off if junction temperature reaches over 150°C to avoid damage.

### Wireless Charging System

FPF3040 can be used for an input power selector supporting Travel Adaptor (TA) and Wireless Charging (WC) with a single-input-based battery charger or Power Management IC (PMIC), including a charging block as shown in Figure 31. The system can recognize an input power source change between 5 V TA and 5 V WC without detection circuitry because FPF3040 has a 100 ms transition delay. OTG Mode can be supported without an additional power path, such as a MOSFET.

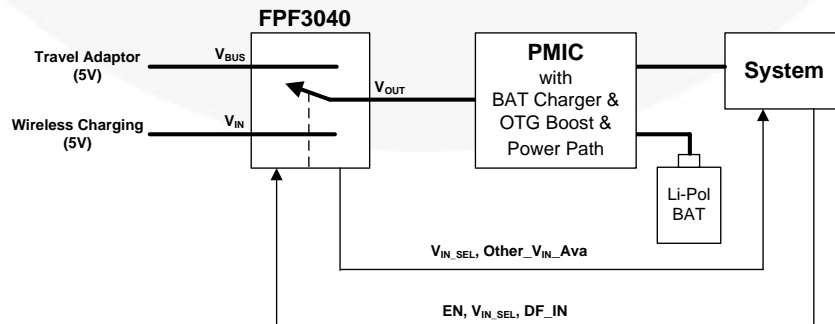

**Figure 31. Block Diagram of Input Power Selector for Wireless Charging System**

**Product Specific Package Information**

D	E	X	Y
1.96 mm ±0.03 mm	1.76 mm ±0.03 mm	0.28 mm	0.38 mm



REVISIONS			
REV	DESCRIPTION	DATE	APP'D / SITE
1	Initial drawing release.	3-31-08	L. England
2	Changed land pad solder mask to individual pad openings. Other general updates for drawing consistency.	3-31-08	L. England / FSME

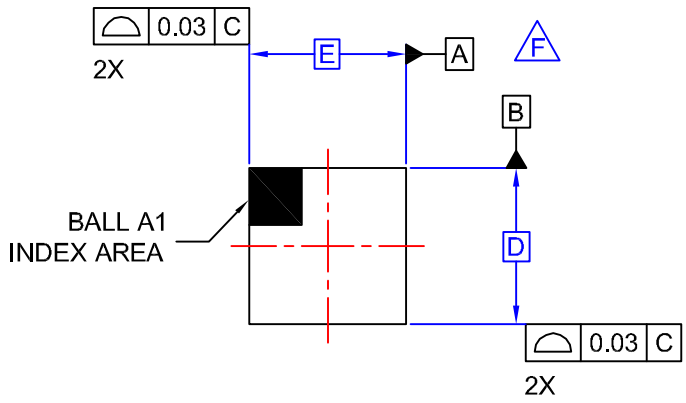

TOP VIEW

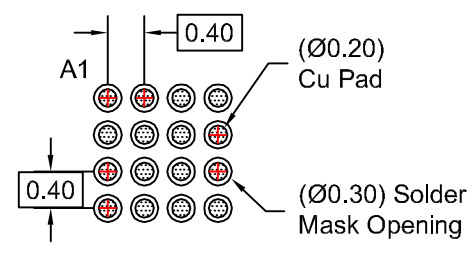

RECOMMENDED LAND PATTERN (NSMD PAD TYPE)

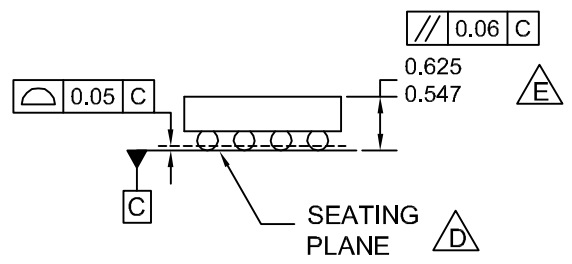

SIDE VIEWS

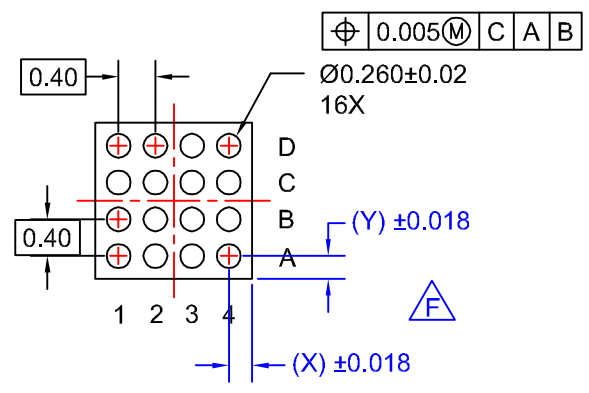
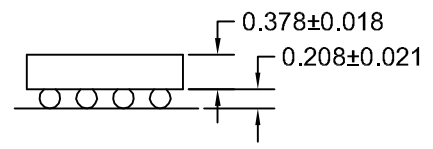

BOTTOM VIEW

NOTES:





- A. NO JEDEC REGISTRATION APPLIES.
- B. DIMENSIONS ARE IN MILLIMETERS.
- C. DIMENSIONS AND TOLERANCE PER ASME Y14.5M, 1994.
- D. DATUM C IS DEFINED BY THE SPHERICAL CROWNS OF THE BALLS.
- E. PACKAGE NOMINAL HEIGHT IS 586 MICRONS ±39 MICRONS (547-625 MICRONS).
- F. FOR DIMENSIONS D, E, X, AND Y SEE PRODUCT DATASHEET.
- G. DRAWING FILNAME: MKT-UC016Arev2.

<b>APPROVALS</b>		<b>DATE</b>			
DRAWN	L. England	10-26-09			
DFTG. CHK.	E. Shacham	10-26-09			
ENGR. CHK.					
			<b>16BALL WLCSP, 4X4 ARRAY</b> <b>0.4MM PITCH, 250UM BALL</b>		
		SCALE	SIZE	DRAWING NUMBER	REV
		N/A	N/A	MKT-UC016AA	2
			DO NOT SCALE DRAWING		SHEET 1 of 1



**TRADEMARKS**

The following includes registered and unregistered trademarks and service marks, owned by Fairchild Semiconductor and/or its global subsidiaries, and is not intended to be an exhaustive list of all such trademarks.

- |   |  |   |   |
|---|--|---|---|
| AccuPower™  | F-PFS™   | OPTOPLANAR®   |  |
| AttitudeEngine™   | FRFET®   |  | TinyBoost®  |
| Awinda®   | Global Power Resource <sup>SM</sup>            | PowerTrench®  | TinyBuck®   |
| AX-CAP®*  | GreenBridge™                                   | PowerXS™  | TinyCalc™   |
| BitSiC™   | Green FPS™                                     | Programmable Active Droop™  | TinyLogic®  |
| Build it Now™   | Green FPS™ e-Series™                           | QFET®   | TINYOPTO™   |
| CorePLUS™   | Gmax™  | QS™   | TinyPower™  |
| CorePOWER™  | GTO™   | Quiet Series™   | TinyPWM™  |
| CROSSVOLT™  | IntelliMAX™                                    | RapidConfigure™   | TinyWire™   |
| CTL™  | ISOPLANAR™                                     |  | TranSiC™  |
| Current Transfer Logic™   | Making Small Speakers Sound Louder and Better™ | Saving our world, 1mW/W/kW at a time™   | TriFault Detect™  |
| DEUXPEED®   | MegaBuck™                                      | SignalWise™   | TRUECURRENT®*   |
| Dual Cool™  | MICROCOUPLER™                                  | SmartMax™   | μSerDes™  |
| EcoSPARK®   | MicroFET™                                      | SMART START™  |  |
| EfficientMax™   | MicroPak™                                      | Solutions for Your Success™   | UHC®  |
| ESBC™   | MicroPak2™                                     | SPM®  | Ultra FRFET™  |
|  | MillerDrive™                                   | STEALTH™  | UniFET™   |
| Fairchild®  | MotionMax™                                     | SuperFET®   | VCM™  |
| Fairchild Semiconductor®  | MotionGrid®                                    | SuperSOT™-3   | VisualMax™  |
| FACT Quiet Series™  | MTI®   | SuperSOT™-6   | VoltagePlus™  |
| FACT®   | MTX®   | SuperSOT™-8   | XS™   |
| FAST®   | MVN®   | SupreMOS®   | Xsens™  |
| FastvCore™  | mWSaver®                                       | SyncFET™  | 仙童™   |
| FETBench™   | OptoHiT™                                       | Sync-Lock™  |   |
| FPS™  | OPTOLOGIC®                                     |   |   |

\* Trademarks of System General Corporation, used under license by Fairchild Semiconductor.

**DISCLAIMER**

FAIRCHILD SEMICONDUCTOR RESERVES THE RIGHT TO MAKE CHANGES WITHOUT FURTHER NOTICE TO ANY PRODUCTS HEREIN TO IMPROVE RELIABILITY, FUNCTION, OR DESIGN. TO OBTAIN THE LATEST, MOST UP-TO-DATE DATASHEET AND PRODUCT INFORMATION, VISIT OUR WEBSITE AT [HTTP://WWW.FAIRCHILDSEMI.COM](http://www.fairchildsemi.com). FAIRCHILD DOES NOT ASSUME ANY LIABILITY ARISING OUT OF THE APPLICATION OR USE OF ANY PRODUCT OR CIRCUIT DESCRIBED HEREIN; NEITHER DOES IT CONVEY ANY LICENSE UNDER ITS PATENT RIGHTS, NOR THE RIGHTS OF OTHERS. THESE SPECIFICATIONS DO NOT EXPAND THE TERMS OF FAIRCHILD'S WORLDWIDE TERMS AND CONDITIONS, SPECIFICALLY THE WARRANTY THEREIN, WHICH COVERS THESE PRODUCTS.

**LIFE SUPPORT POLICY**

FAIRCHILD'S PRODUCTS ARE NOT AUTHORIZED FOR USE AS CRITICAL COMPONENTS IN LIFE SUPPORT DEVICES OR SYSTEMS WITHOUT THE EXPRESS WRITTEN APPROVAL OF FAIRCHILD SEMICONDUCTOR CORPORATION.

As used herein:

- Life support devices or systems are devices or systems which, (a) are intended for surgical implant into the body or (b) support or sustain life, and (c) whose failure to perform when properly used in accordance with instructions for use provided in the labeling, can be reasonably expected to result in a significant injury of the user.
- A critical component in any component of a life support, device, or system whose failure to perform can be reasonably expected to cause the failure of the life support device or system, or to affect its safety or effectiveness.

**ANTI-COUNTERFEITING POLICY**

Fairchild Semiconductor Corporation's Anti-Counterfeiting Policy. Fairchild's Anti-Counterfeiting Policy is also stated on our external website, [www.fairchildsemi.com](http://www.fairchildsemi.com), under Sales Support.

Counterfeiting of semiconductor parts is a growing problem in the industry. All manufacturers of semiconductor products are experiencing counterfeiting of their parts. Customers who inadvertently purchase counterfeit parts experience many problems such as loss of brand reputation, substandard performance, failed applications, and increased cost of production and manufacturing delays. Fairchild is taking strong measures to protect ourselves and our customers from the proliferation of counterfeit parts. Fairchild strongly encourages customers to purchase Fairchild parts either directly from Fairchild or from Authorized Fairchild Distributors who are listed by country on our web page cited above. Products customers buy either from Fairchild directly or from Authorized Fairchild Distributors are genuine parts, have full traceability, meet Fairchild's quality standards for handling and storage and provide access to Fairchild's full range of up-to-date technical and product information. Fairchild and our Authorized Distributors will stand behind all warranties and will appropriately address any warranty issues that may arise. Fairchild will not provide any warranty coverage or other assistance for parts bought from Unauthorized Sources. Fairchild is committed to combat this global problem and encourage our customers to do their part in stopping this practice by buying direct or from authorized distributors.

**PRODUCT STATUS DEFINITIONS**

**Definition of Terms**

Datasheet Identification	Product Status	Definition
Advance Information	Formative / In Design	Datasheet contains the design specifications for product development. Specifications may change in any manner without notice.
Preliminary	First Production	Datasheet contains preliminary data; supplementary data will be published at a later date. Fairchild Semiconductor reserves the right to make changes at any time without notice to improve design.
No Identification Needed	Full Production	Datasheet contains final specifications. Fairchild Semiconductor reserves the right to make changes at any time without notice to improve the design.
Obsolete	Not In Production	Datasheet contains specifications on a product that is discontinued by Fairchild Semiconductor. The datasheet is for reference information only.

Rev. I73