



Main

Range of product	Modicon TM5
Product or component type	Discrete input module
Discrete input number	6
Discrete input voltage	24 V

Complementary

Range compatibility	Modicon LMC058 Modicon M258
Product compatibility	Motion controller Logic controller
Discrete input voltage type	DC
Input voltage limits	20.4...28.8 V
Discrete input logic	Sink
Discrete input current	3.75 mA
Input impedance	6.4 kOhm
Colour	White
Voltage state 0 guaranteed	≤ 5 V
Voltage state 1 guaranteed	≥ 15 V
Input filtering	≤ 100 ms hardware 0...25 ms configurable by software
Current consumption	37 mA 24 V DC all inputs On 30 mA 5 V DC bus
Power dissipation in W	≤ 1.03 W
Local signalling	6 LEDs green for input status 1 LED red for power supply 1 LED green for power supply
Electrical connection	2 wires
Marking	CE
Product weight	0.025 kg

Environment

Standards	CSA 22-2 No 142 IEC 61131-2 UL 508 CSA 22-2 No 213
Product certifications	CSA C-Tick CULus GOST-R
Ambient air temperature for operation	0...60 °C with derating factorhorizontal installation 0...55 °C without derating factorhorizontal installation 0...50 °C vertical installation
Ambient air temperature for storage	-25...70 °C
Relative humidity	5...95 % without condensation
IP degree of protection	IP20 conforming to IEC 61131-2

Pollution degree	2 conforming to IEC 60664
Operating altitude	0...2000 m
Storage altitude	0...3000 m
Vibration resistance	3.5 mm 5...8.4 Hz DIN rail 1 gn 8.4...150 Hz DIN rail
Shock resistance	15 gn for 11 ms
Resistance to electrostatic discharge	8 kV in air conforming to EN/IEC 61000-4-2 4 kV on contact conforming to EN/IEC 61000-4-2
Resistance to electromagnetic fields	10 V/m 80...2000 MHz conforming to EN/IEC 61000-4-3 1 V/m 2...2.7 GHz conforming to EN/IEC 61000-4-3
Resistance to fast transients	2 kV power lines conforming to EN/IEC 61000-4-4 1 kV shielded cable conforming to EN/IEC 61000-4-4 1 kV I/O conforming to EN/IEC 61000-4-4
Surge withstand	1 kV common mode conforming to EN/IEC 61000-4-5 0.5 kV differential mode conforming to EN/IEC 61000-4-5
Electromagnetic compatibility	EN/IEC 61000-4-6
Disturbance radiated/conducted	CISPR11

Not classified

Isolation	No insulation between channels 500 Vrms AC insulation between channel and bus
-----------	--

Offer Sustainability

Sustainable offer status	Not Green Premium product
RoHS	Compliant - since 1039 - Schneider Electric declaration of conformity download declaration of conformity

TM5 Slice

Dimensions

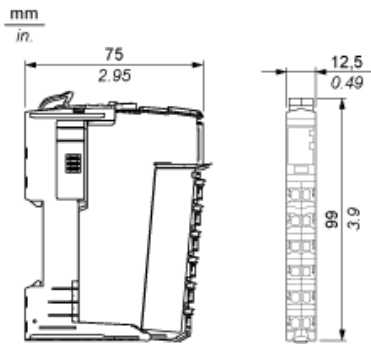

TM5 System

Spacing Requirements

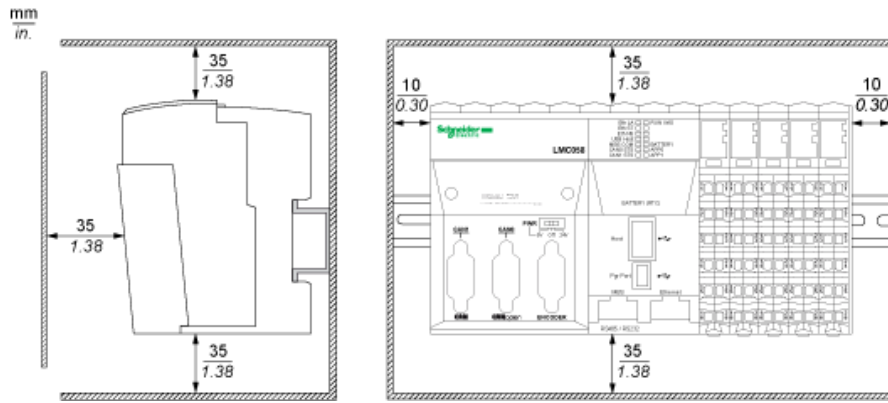



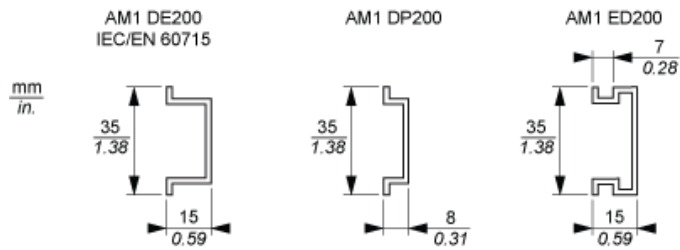

Mounting on a DIN Rail



TM5 System Wiring Recommendations

Wire Sizes to Use with the Removable Spring Terminal Blocks

mm in.				
mm ²	0,08...2,5	0,25...2,5	0,25...1,5	2 x 0,25...2 x 0,75
AWG	28...14	24...14	24...16	2 x 24...2 x 18

Electronic Module 6DI 24 Vdc Sink 2 Wires

Wiring Diagrams

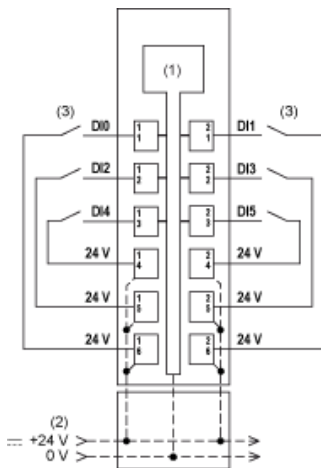

- (1) Internal electronics
- (2) 24 Vdc I/O power segment integrated into the bus bases
- (3) 2-wire sensor

To connect 3-wire electronic sensors, you can add a TM5SPDG6D6F Common Distribution module:

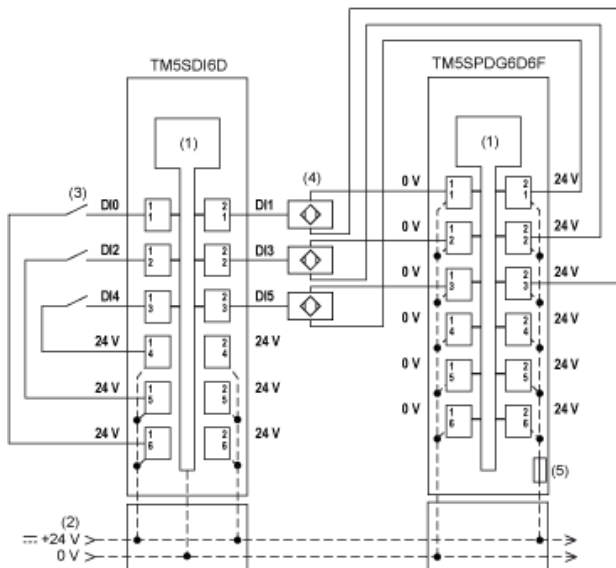

- (1) Internal electronics
- (2) 24 Vdc I/O power segment integrated into the bus bases
- (3) 2-wire sensor
- (4) 3-wire sensor
- (5) Integrated fuse type T slow-blow 6.3 A 250 V exchangeable