

特点

- PTFE 双绞线，用于延长或制作简单的热电偶
- 单对 PTFE 绝缘导线绞合在一起
- 优良的机械强度和柔韧性
- 容差等级 1、确保最佳精确度

热电偶电线 k 型、 -10 → +105 °c 2 芯非屏蔽 pvc 护套 25m

RS 库存号: 363-0389

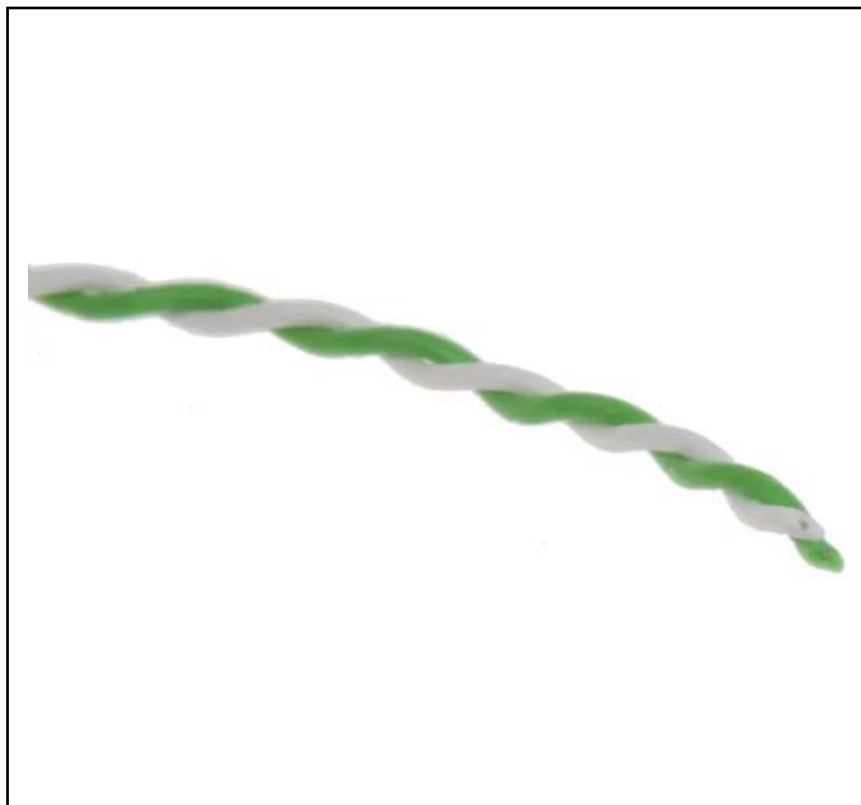

RS 认证产品为您提供所有产品类别的专业品质部件。我们的产品系列经过工程师测试、提供与杰出品牌相当的质量、而无需支付高昂的价格。

产品说明

深受信赖的 RS Pro pro 提供一系列高质量和超值热电偶延长电缆。这些延长线按照工业标准制造、是延长温度探头和提供读数的仪器之间距离的出色解决方案。

一般规格

热电偶类型	k
内核数	2; 7; 12
屏蔽 / 未屏蔽	非屏蔽
绝缘材料	聚四氟乙烯
电缆形状	扭曲
绞线数	1
符合标准	iec 584
应用	医疗 - 研究 dna 和皮下插入以检测肿瘤；车辆诊断 - 用于监测和调整因素、如电池健康状况、排气读数、火花塞功能和制动性能；锅炉、加热传感器和烤箱中的温度读数；食品温度计、工业探头和传感器

电气规格

最大功耗	20VA 在充电过程中降至 170VA
回路电阻	在 4.5 欧姆 / 米时键入 k

机械规格

长度	25m
芯线束	1/0.2mm
绞线尺寸	0.2mm
能量输出	0-60 焦耳
焊丝容量	直径高达 1.1 mm
最小占空比	5-10 个焊接 / 分钟
物理尺寸	220mm 宽 x 120mm 高 x 250mm 深
重量	4kg
部分	0.032mm ²

操作环境规格

最低工作温度	-75°C
最高工作温度	260°C

认证

合规性 / 认证	rohs 合规性证书
----------	------------





(Front View)



(Rear View)



Thermocouple Welder Controls

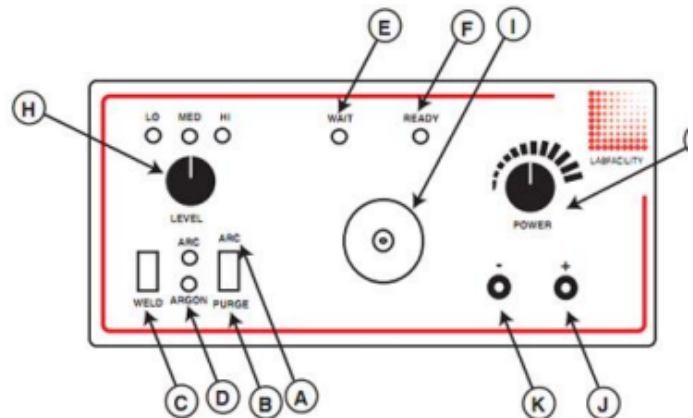

- | | | |
|---|------------------|-----------------------------------------------------------------------------------------------|
| A | Arc | Argon gas and weld current controlled by the "Weld" switch. LED indication |
| B | Purge | Allows the gas line and electrode shield to be purged of air prior to a new welding period |
| C | Weld Switch | Initiates a welding operation (in "arc" mode also opens the Argon valve) |
| D | Argon LED | Indicates when the Argon control valve is open and gas is flowing |
| E | Wait LED | Glow when weld charge is building |
| F | Ready LED | "Ready to Weld" indication |
| G | Power | Rotary control of the capacitor charge voltage |
| H | Level Selector | Selects the total capacitance available giving the following values with LED indication |
| | | "LO" = 0 to 6 Joules |
| | | "MED" = 0 to 28 Joules |
| | | "HI" = 0 to 64 Joules |
| I | Electrode Holder | Holds the replaceable carbon electrode which is accessible by removing the outer Argon Shield |
| J | Red Socket | Output socket for using the pliers supplied |
| K | Black Socket | Output socket, this provides an additional earth |

T/C Type	Conductors	mm ²	Cores	Reel Length	Allied code	RS order code
KX	1/0.2mm	0.032	+Green/-White	10 metres	70657140	827-5801
KX	1/0.2mm	0.032	+Green/-White	25 metres	70643608	363-0389
KX	1/0.2mm	0.032	+Green/-White	50 metres	70657141	827-5805
KX	1/0.2mm	0.032	+Green/-White	100 metres	70657144	827-5814
TX	1/0.2mm	0.032	+Brown/-White	10 metres	70657145	827-5817
TX	1/0.2mm	0.032	+Brown/-White	25 metres	70643609	363-0402
TX	1/0.2mm	0.032	+Brown/-White	50 metres	70657143	827-5811
TX	1/0.2mm	0.032	+Brown/-White	100 metres	70657146	827-5820