

LOC	DIST	REVISIONS					
E	B	P	LYR	DESCRIPTION	DATE	DWN	APVT
		B		EB00 - 0304 -01	25-9-01	RG	FWK

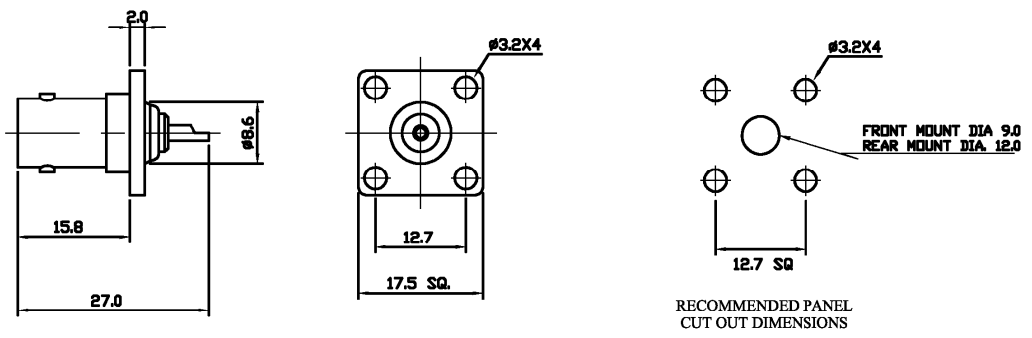

ALL DIMENSIONS ARE NOMINAL. FOR REFERENCE ONLY.

△ PART 1-1337446-1 IS FOR 75 Ohm APPLICATIONS

DIE SET PART NUMBER	N/A
HANDTOOL PART NUMBER	N/A
FOR USE ON CABLES	N/A
CONNECTOR PLATING DETAIL	SILVER
CONTACT PLATING DETAIL	SILVER
DIELECTRIC MATERIAL	TEFLON
GASKET MATERIAL	N/A

THIS DRAWING IS A CONTROLLED DOCUMENT.

DIMENSIONS:	TOLERANCES UNLESS OTHERWISE SPECIFIED:
MM	
0 PL/C	+
1 PL/C	±
2 PL/C	±
3 PL/C	±
4 PL/C	±
ANGLES	±
MATERIAL	FINISH
-	-

DMR	07-SEP-00
R. SMITH	
DKR	07-SEP-00
R. GOODALL	
APVD	07-SEP-00
R. GOODALL	
PRODUCT SPEC	108-3435
APPLICATION SPEC	
WEIGHT	-
CUSTOMER DRAWING	

BAG	SINGLE ITEM	△	1-1337446-1
BAG	SINGLE ITEM		1-1337446-0
PACK TYPE	DESCRIPTION	PART NUMBER	
	BNC PANEL SOCKET		
	50 Ohm AND 75 Ohm		
SIZE	CAGE CODE	DRAWING NO	RESTRICTED TO
A3	00779	1337446	-
SCALE	NTS	SHEET	1 OF 1
		REV	B