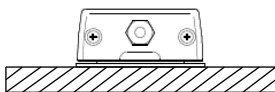
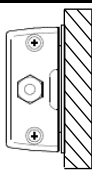
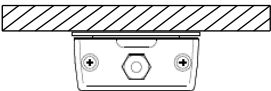

Drawing No.	Rev.	Page
SZW-305-W18	A	1/1

SPECIFICATIONS

[1. General Specifications]

Model	SZW-305		
Compatible models	CLK□-02□N-C□		
Mounting Location	Indoor		
Mounting Direction	Upright	Sideways	Inverted
			
Mass (Tolerance ±10%)	0.09kg (0.045kg×2, Included accessories)		
Quantity	2		
Vibration Resistance	20 m/s ² (IEC 60068-2-6:2009)		
Environmental Condition	Upright		
Shock Resistance	100m/s ² 16ms 1,000 times, 150m/s ² 11ms 3 times(IEC 60068-2-27)		
Environmental Condition	Upright		
Remarks	No restricted substances exceeding the thresholds of the RoHS Directive are contained.		

[2. Outer Dimension]

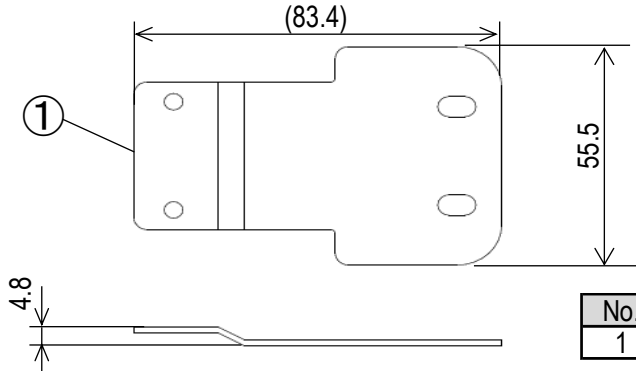

(Unit:mm)

No.	Name	Material	Quantity
1	Bracket	SUS	2

[3. Mounting Dimensional Drawing]

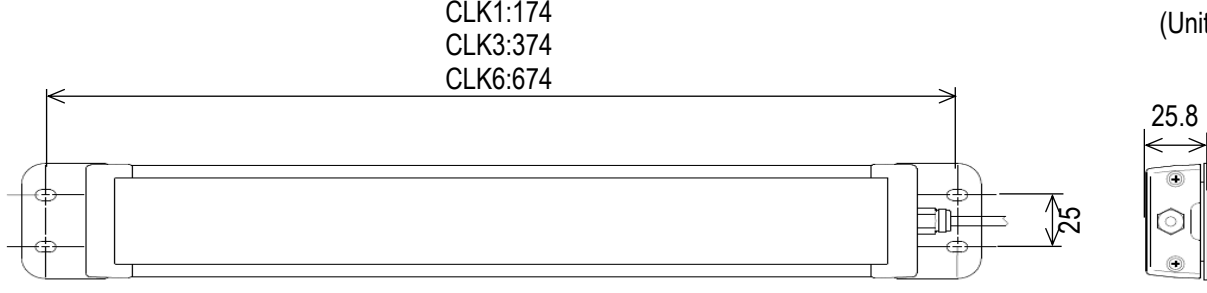

(Unit:mm)

Screw / Nut	Recommended Torque
Product Mounting M5	2.8 N·m
Bracket Mounting M4	1.4 N·m

Accessories	Quantity
Bracket Mounting Screw	4