

# EM-347 BRUSHLESS DC-MOTOR DRIVER 12-36V 40A



## FEATURES

- To the motors with HALL sensors
- Three phase output
- Speed and torque adjustment
- Open/closed loop modes
- Dynamic braking
- Control output for cooling fan.
- True 4Q-power stage
- Braking resistor output
- Selectable brake mode
- Current limit and trip
- Symmetrical control option  $\pm 5V$  or  $\pm 10V$
- Fault and overcurrent outputs
- Good efficiency
- Low EMC emissions
- DIN-rail mountable
- Rpm-pulse output option

## GENERAL

EM-347 is brushless DC-motor driver with hall sensor feedback. The unit has a mosfet power stage with good efficiency and it also meets today's EMC requirements. The driver can be used with 120° commutation. This driver has true 4Q power stage, and it makes possible to use regenerative braking. In this braking method the supply voltage rises at braking. The voltage rising can be controlled with braking resistor. If uses battery supply then the braking energy can be leaded back to the battery and braking resistor will not be required. The unit has the basic digital command inputs like direction, brake, start/stop, disable and there is analog inputs for speed and current control. One digitally presettable second speed (speed-2) is possible to activate with digital command input. EM-347 has two NPN outputs for fault and overcurrent indication use. Some input and output functions can be modified with parameters. Driver includes overvoltage, undervoltage and overtemperature protections. These fault situations are indicated with fault on-board LED. Overtemperature and current limit situations can be reset with reset input, reset-timer or by setting analog speed control to value to 0.

There are two control options for speed. Direct control (open loop) sets motor voltage in proportion to control voltage as with a standard DC-motor. Closed loop uses hall sensor feedback for speed control, this mode offers good speed regulation. Start and stop ramps work in both mode. Speed adjust range, closed loop rpm range and ramp can be set with parameter. Analog input are filtered so that there can be used also PWM signal for control speed and current.

Setting can be done digitally with EM-236 interface unit or with Emen-Tool lite program installed in PC and EM-268 or EM-328 adapter cable. Parameters stored into nonvolatile memory of device. This interface unit can also be monitored the current and rpm of motor. Device has also output for cooling fan, it can be controlled optional fan if needed. This output switch on fan, when temperature rises over 65 deg.

Device can be installed in DIN-rail base and some enclosure options are also available.

## TECHNICAL DATA

Supply voltage 12-36V ( 11-42Vdc )  
 Overvoltage limit 15-65V ( adjustable )  
 Idle current typ. 30mA  
 Max current 40A cont ( Tamb. 50 °C )  
 Max current 50A cont. with fan cooling  
 Max current peak 100A ( max 2s )  
 Max brake output current 25A  
 Brake resistor recom.value 1-10ohm  
 Pwm frequency typ. 16kHz ( 2kHz option )  
 Overtemperature shut down 90 °C  
 Fan output switch on > 65 °C  
 Current limit setting 1-100A ( step 1 A )  
 Current limit analog scale 0-5V = 0-100A  
 Logic level of digital inputs  
 "off" = 0-1V or open / "on" = 4-30V  
 Input impedance of logic inputs 10k  
 Response time of digital input 2ms  
 Analog input range 0-5V up to 0-10V  
 Input impedance of analog inputs 100k  
 Input filter of analog input 100Hz  
 Overcur. and fault outputs NPN max 50mA  
 Output for fan cooling 12V max. 100mA  
 EMC measured for industrial environment  
 PCB material flammability class UL94V-0  
 Dimensions 140x122x50mm  
 Weight 650g

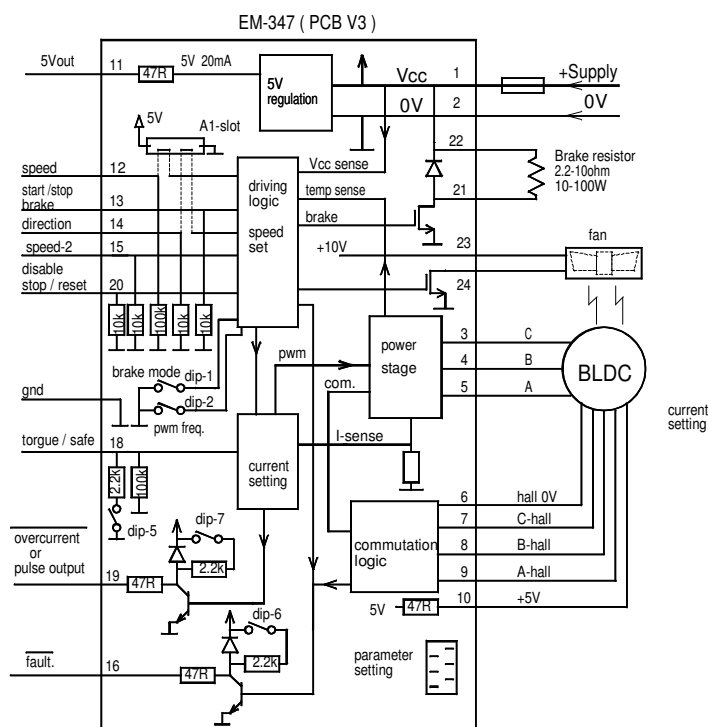

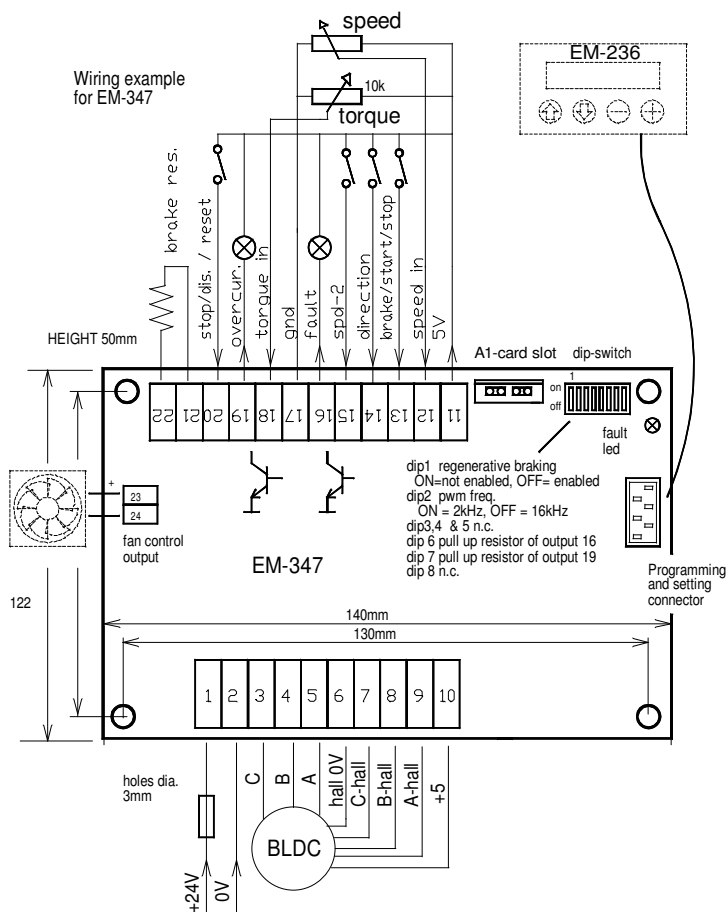

### SETTABLE PARAMETERS ( prog. 347 v1.3 )

EM-347 parameters set with interface unit EM-236 or with Ementool-Lite and EM-268

- mode: open loop =0 / closed loop=1 ( 0 )
- closed loop range 0-4 ( 3 )  
0=3000rpm  
1=1500rpm  
2=900rpm  
3=500rpm  
4=300rpm
- start ramp 0-5s / 0-50 ( 1s )
- stop ramp 0-5s / 0-50 ( 1s )
- I-trip delay 0.01-2.5s / 0-255 0=no trip ( 0.2s )
- scale start speed 0-25.5% / 0-255 ( 0 )
- scale gain 0-2.55 / 0-255 ( 200 )
- closed loop dynamic P-factor 1-200 ( 10 )
- closed loop dynamic I-factor 1-200 ( 10 )
- braking current limit 10-50A / 10-50 ( 50 )
- pin 13 input mode  
0 = start / stop ramp/brake ( speed-2 with brake )  
1 = start / stop with ramp  
2 = start / stop with braking
- current limit 0-100A / 1-100 ( 40 )  
0 = current setting with pin 18
- speed-2 value 0-100% / 0-100 ( 50 )
- I-trip reset mode ( 0 )  
0 = only with disable pin  
1 = with speed input change 0 to up  
2 = with direction input  
10-200 = timer reset 1-20s. ( 0 )
- Over temp reset mode ( 0 )  
0 = only with disable input  
1 = with speed input change 0 to up  
2 = 10-200 timer reset 1-20s.
- I-trip indication ( 0 )  
0 = I-trip indication to pin 16  
1 = No I trip indication to pin 16 or 19  
2 = I-trip indication to pin 19  
3 = pin 19 reserved only for I-trip indication
- pulse output for pin 19 0-5 ( 0 )  
0 = not in use = pin 19 set with parameter 16 )  
1 = 3pulse/round ( possible only when param 2 is 2,3 or 4 )  
2 = 1pulse/round  
3 = 1pulse/2round  
4 = 1pulse/3round  
5 = 1pulse/6round
- brake res. treshold (=overtorque) 15-65V / 15-65 (36)

### MONITOR VALUES

- current 0-250A / 0-250
- braking current 0-250A / 0-250
- hall freq. 0-1000 / 0-1000Hz

### TAKE IN USE

Operating voltage 12-36Vdc ripple less than 20% ( abs. max 42Vdc )  
An external supply fuse is recommended ( 10-60A )

Be carefully when connect motor wires, because there is lot of combination.  
If motor takes much current or run roughly then change wiring.

Default settings are in brackets in parameter list. These are good start-up values

In example picture beside there all input connected, but device work also with less wiring. So connect only needed functions.

Overcurrent and fault outputs are NPN type, and pull when activates, This could also connect to PNP input if uses 2.2k external pull up resistor

In high power application there can be installed DC-fan into driver to improve cooling. Driver has own connector for fan. This output offer regulated DC- voltage ( 12V ). This output will activate when driver temperature exceed 65°C.

Speed adjusting input range can be set with parameter 6 and 7. see picture below

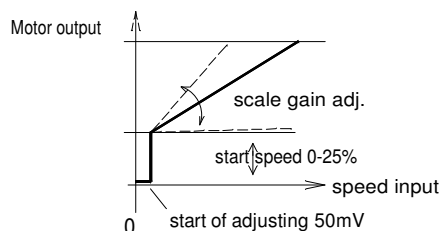

If symmetrical control is needed ( $\pm 5V$  or  $\pm 10V$ ), then can be added EM-A1 auxiliary card into A1 slot.  
In symmetrical control the rotation direction determined by polarity of control signal and the middle point ( 0 ) is same as STOP.  
The installing of EM-A1 modified inputs next:  
SPEED input 0-5V / 0-10V turns  $\pm 5V$  or  $\pm 10V$  input  
DIRECTION input turns -5V output. this voltage can be used for potentiometer, see drawing right.  
Instead of potentiometer can be used also symmetrical voltage signal.

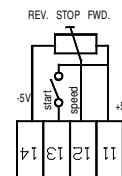

### BRAKING

In some application the load can generates energy back to drive, when slowing down speed. In this case you need braking resistor, which absorbed extra energy.  
NOTICE that the parameter 18 has to be set about 10% higher than unloaded voltage of power supply.  
If using battery supply, then braking resistor would not needed.

### CONTROL INPUTS

SPEED input is a analog control input for speed setting.  
Set signal can be between 0-5V and 0-10V  
Speed scaling can be made with parameter 6 and 7.

TORQUE input is analog input for current limit setting.  
0-5V signal to 0-100A current. ( if parameter 12 is =0 )  
If parameter value is something else than zero, then current limit is then = parameter value + analog input value.

Analog inputs above can also control with PWM signal.  
Recommended PWM frequency is over 400Hz.

BRAKE/START/STOP input is a digital input. Normally this actives brake function. It means that motor poles shorted and speed set to zero. But this input can be set to work also as start/stop input.  
Input functions can be set with parameter 11.  
In start/stop mode the start work with positive command.  
NOTICE ! Current limit doesn't limit braking current, so it is not recommend to use this for long and high inertia braking.

DIRECTION input is a digital input. It will change the rotation direction. It uses automatically stop/start ramps during change.

SPEED-2 input is a digital input which. enables speed-2,  
Speed presetted with parameter 13.

STOP/ DISABLE input is a digital input, which disabled driver  
Motor goes to freewheeling ( all poles floating ). This input can be set to work also as reset with parameter 14 and 15  
This input has highest priority.

### INDICATIONS.

Fault led:  
Fast blinking = I-trip or overvoltage  
Random blinking = current limit, braking current limit.  
Continuous = overtemp, disable input "on", undervoltage

Fault output: ( Pin-16 PNP open collector output )  
Overtemperature, Overvoltage, Undervoltage.  
This indicates also I-Trip if parameter 16 is set to = 0

Overcurrent output : ( pin-19 PNP open collector out )  
This output indicates when current limit is exceeded.  
- if parameter 16 is set to =2 then it indicates also I-trip  
- if parameter 16 is set to =3 then it indicates only I-trip