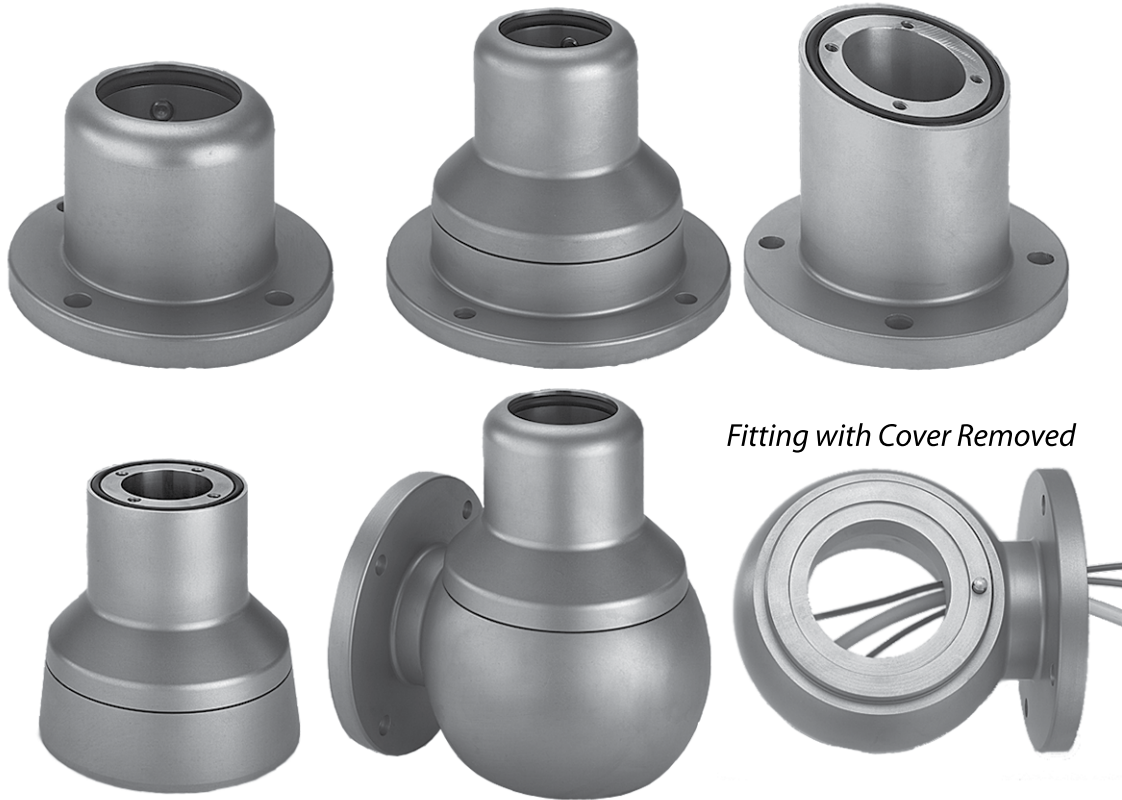

**CS480 STAINLESS STEEL PENDANT ARM SYSTEM**

*Fitting with Cover Removed*
**INDUSTRY STANDARDS**

IEC 60529, IP66

**APPLICATION**

The CS480 Stainless Steel Pendant Arm System performs extremely well in food and pharmaceutical applications that require corrosion resistance and suspension of process and control equipment for easy cleaning. The CS480 system has a high degree of design configuration flexibility. (For possible design combinations, see the System Combinations Drawings.) Used for lighter loads, the CS480 system's load rating at 3.3 ft. (1 m) is 89.6 lb. (40.7 kg). Ratings for other loads are shown in the Load Capacity chart.

**SPECIFICATIONS**

- Tubing clamps into position with setscrews for easy assembly and smooth appearance
- Fixed or swivel mounting, straight or at a 15-degree angle
- 90-degree fittings have a removable cover that allows easy access for wiring
- The coupling hole geometrics for enclosure machining are shown in the Coupling Hole Geometry diagram

**FINISH**

Tubing: Type 304 polished stainless steel  
 Fittings: Type 304 polished stainless steel

*Brushed stainless steel shown.*

Coupling Hole Geometry for Enclosure Machining

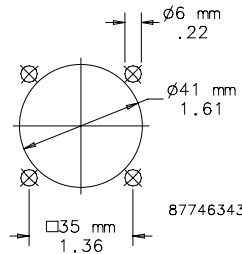

**SYSTEM LOAD CAPACITY**

The load capacity of the CS480 Pendant Arm System is shown in the diagram. Choose the CS600 System for larger loads.

Load Rating

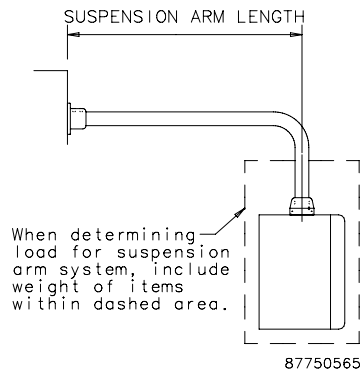

Maximum Recommended Load (lb/kg)

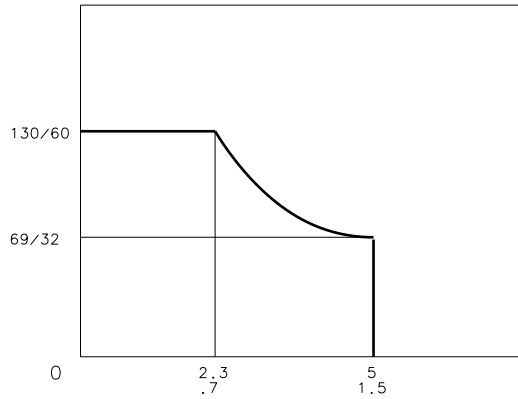

Suspension Arm Length (ft/m)

89001156

**SYSTEM COMBINATIONS**

The wide variety of components permits a high level of flexibility in configuring the system. Some possible combinations are shown here.

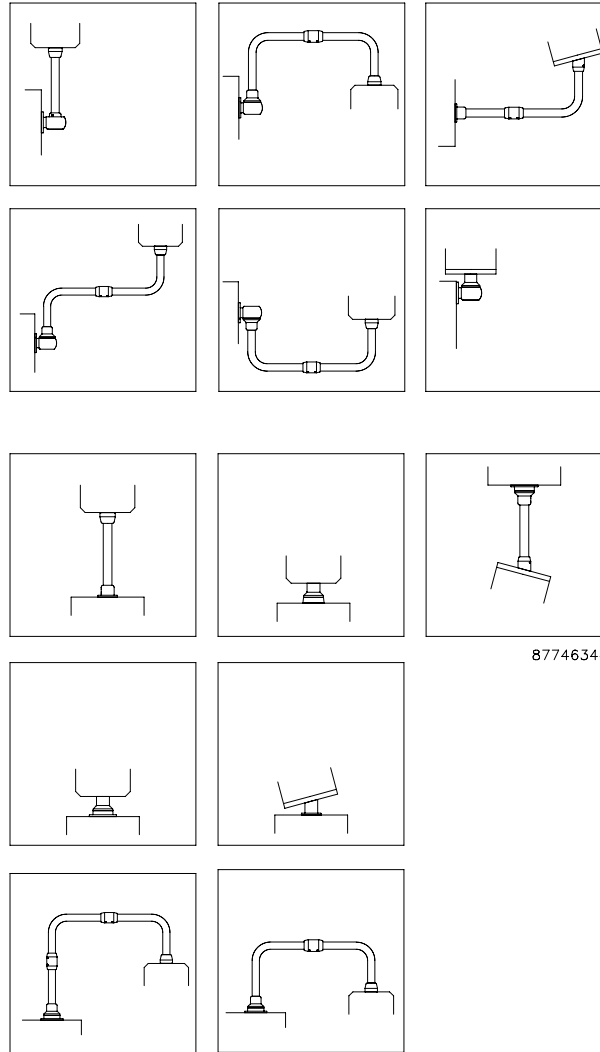

**STRAIGHT TUBING**



Straight Tubing has an outer diameter of 48.3 mm (1.90 in.) and is made from 3.6-mm wall thickness Type 304 polished stainless steel.

**BULLETIN: CCR6**

Catalog Number	L mm/in.	Product Weight (kg)	Product Weight (lb.)
CCSS48T25	250 9.84	1.13	2.5
CCSS48T50	500 19.69	2.13	4.7
CCSS48T75	750 29.53	3.18	7.0
CCSS48T100	1000 39.37	4.40	9.7
CCSS48T125	1250 49.21	5.44	12.0
CCSS48T150	1500 59.06	6.67	14.7

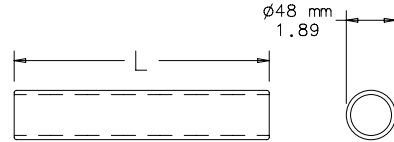

87799211

**L-SHAPED TUBING**



L-Shaped Tubing has an outer diameter of 48.3 mm (1.90 in.) and is made from 3.6-mm-thick Type 304 polished stainless steel. It is used with coupling sleeves and straight tubing to provide the desired system configuration.

**BULLETIN: CCR6**

Catalog Number	L mm/in.	Product Weight (kg)	Product Weight (lb.)
CCSS48TLB25	250 x 250 9.84 x 9.84	2.4	5.3
CCSS48TLB50	500 x 500 19.69 x 19.69	4.76	10.5

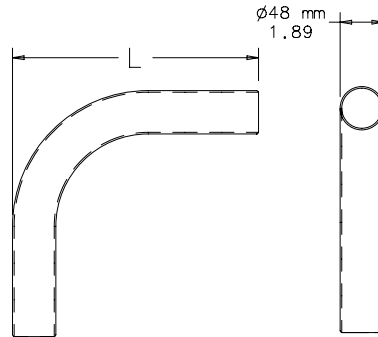

87799212

### L-SHAPED STAINLESS STEEL PENDANT TUBES



L-Shaped Pendant Tubes are made of Type 304 stainless steel with an outer diameter of 48 mm (1.90 in.) and have a smooth finish. For use in conjunction with CS480 stainless steel pendant fittings. Use of these tubes does not compromise the enclosure rating.

**BULLETIN: CCR6**

Catalog Number	A mm/in.	B mm/in.	Product Weight (kg)	Product Weight (lb.)
CCSSTL5024	500 19.69	240 9.45	2.6	5.7
CCSSTL10050	1000 39.37	500 19.69	5.4	11.9

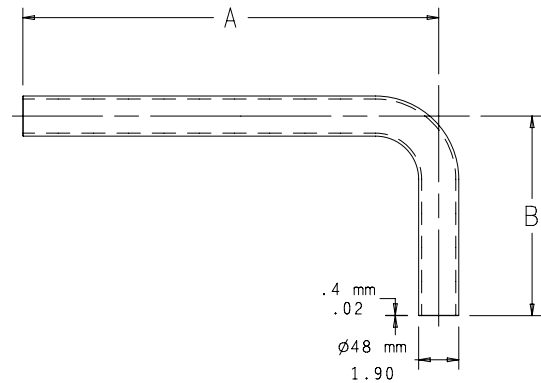

87780230

### U-SHAPED STAINLESS STEEL PENDANT TUBES



U-Shaped Pendant Tubes are made of Type 304 stainless steel with an outer diameter of 48 mm (1.90 in.) and have a smooth finish. For use in conjunction with CS480 stainless steel pendant fittings. Use of these tubes does not compromise the enclosure rating.

**BULLETIN: CCR6**

Catalog Number	AxBxC in./mm	Product Weight (kg)	Product Weight (lb.)
CCSSTU502450	19.69 x 9.45 x 19.69 500 x 240 x 500	4.5	9.9
CCSSTU802480	31.50 x 9.45 x 31.50 800 x 240 x 800	6.7	14.8

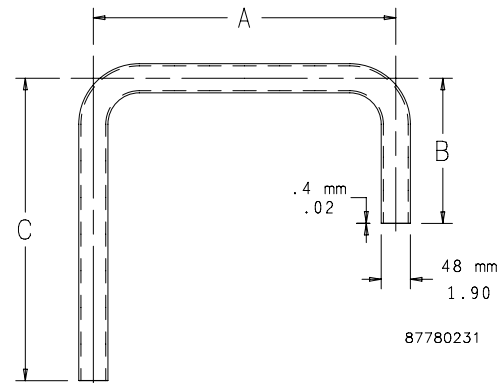

87780231

### COUPLING SLEEVE



The Shaped Pendant Tubes joins sections of tubing in the CS480 System. Type 304 polished stainless steel finish. Includes gaskets.

**BULLETIN: CCR6**



Catalog Number	Description	Product Weight (kg)	Product Weight (lb.)
CCSS48CS	CS480 system coupling sleeve	1.4	3.5

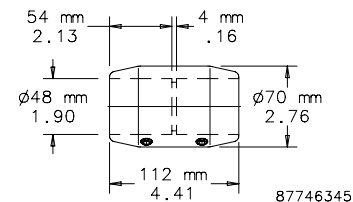

87746345

### STRAIGHT COUPLING



Flange coupling for attaching enclosures. Turns through 340 degrees with rotation limiter. Preset torque. Maintenance-free bearings. Type 304 polished stainless steel finish. Includes gaskets and mounting hardware.

**BULLETIN: CCR6**



Catalog Number	Description	Product Weight (kg)	Product Weight (lb.)
CCSS48FC	Straight coupling for enclosure	1.4	3.5

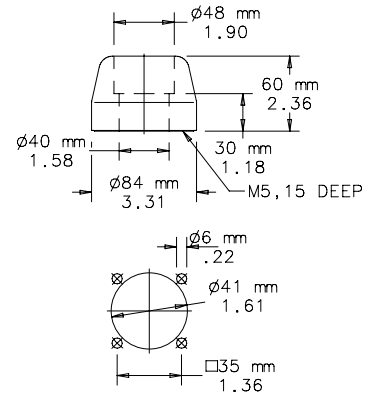

87799214

NOTE: Recommended mounting hole size shown.

### ANGLE COUPLING



Rigid flange coupling with 15-degree angle of inclination for attaching enclosures. Type 304 polished stainless steel finish. Includes gaskets and mounting hardware.

**BULLETIN: CCR6**



Catalog Number	Description	Product Weight (kg)	Product Weight (lb.)
CCSS48AC15	Angle coupling for enclosures	1.0	2.0

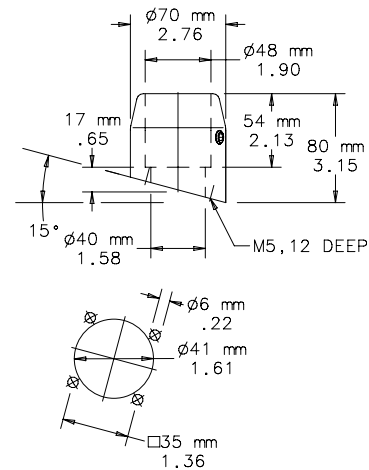

87746346

NOTE: Recommended mounting hole size shown.

**SWIVEL BASE FOR EXTERNAL ATTACHMENT**

Swivel Base for mounting to machine or floor. Turns through 340 degrees with rotation limiter. Preset torque. Maintenance-free bearings. Type 304 polished stainless steel finish. Includes gaskets. Base-mounting fasteners not provided.

**BULLETIN: CCR6**



Catalog Number	Description	Product Weight (kg)	Product Weight (lb.)
CCSS48BBRE	Swivel base, external	4.2	9.5

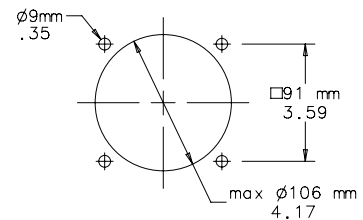
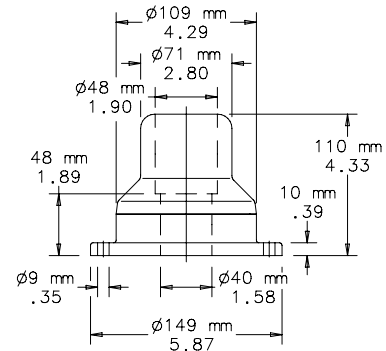

87799217

*NOTE: Recommended mounting hole size shown.*

**SWIVEL BASE FOR INTERNAL MOUNTING**

Swivel Base for mounting to machine or floor. Turns through 340 degrees with rotation limiter. Preset torque. Maintenance-free bearings. Type 304 polished stainless steel finish. Includes gaskets. Base-mounting fasteners not provided.

**BULLETIN: CCR6**



Catalog Number	Description	Product Weight (kg)	Product Weight (lb.)
CCSS48BBRI	Swivel base, internal	4.2	9.5

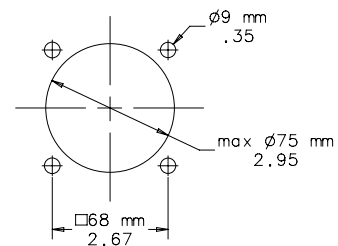
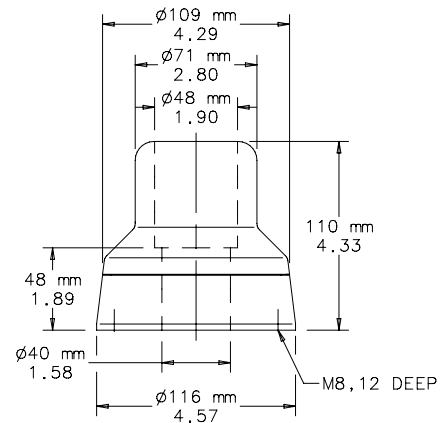

87746348

*NOTE: Recommended mounting hole size shown.*

### BASE BRACKET/WALL FLANGE



Use as Base Bracket or Wall Flange to mount to vertical or horizontal surfaces. Type 304 polished stainless steel finish. Includes gaskets. Base-mounting fasteners not provided.

**BULLETIN: CCR6**

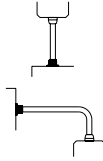

Catalog Number	Description	Product Weight (kg)	Product Weight (lb.)
CCSS48BB	Base bracket/wall flange	1.4	3.5

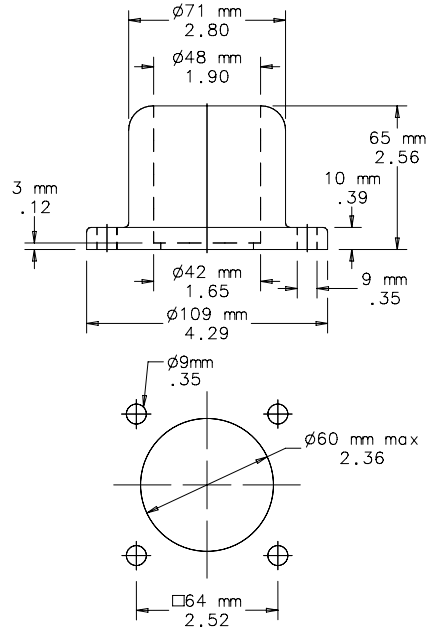

87799220

NOTE: Recommended mounting hole size shown.

### BASE BRACKET ANGLE COUPLING



Rigid 15-degree coupling for direct mounting of enclosures to horizontal and vertical surfaces. Type 304 polished stainless steel finish. Includes gaskets and enclosure mounting hardware. Base-mounting fasteners not provided.

**BULLETIN: CCR6**



Catalog Number	Description	Product Weight (kg)	Product Weight (lb.)
CCSS48ACBB	Base bracket angle coupling	1.9	4.5

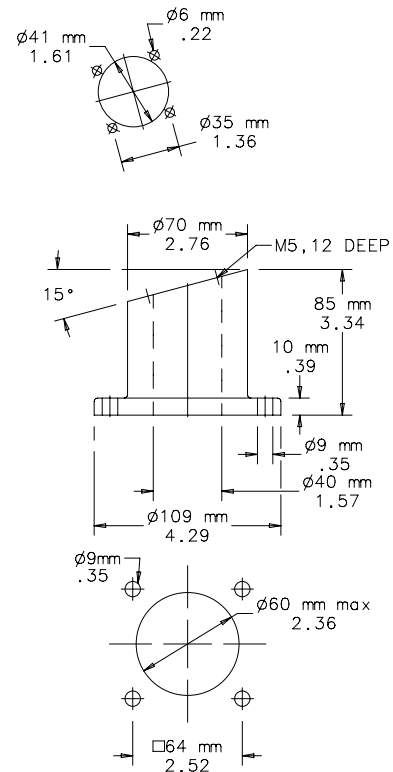

87746349

NOTE: Recommended mounting hole size shown.



**SWIVEL BASE EXTERNAL BRACKET COUPLING**

Swivel Base External Bracket Coupling for mounting enclosures directly to a machine or the floor. Turns through 340 degrees with rotation limiter. Preset torque. Maintenance-free bearings. Type 304 polished stainless steel finish. Includes gaskets and enclosure mounting hardware. Base-mounting fasteners not provided.

**BULLETIN: CCR6**



Catalog Number	Description	Product Weight (kg)	Product Weight (lb.)
CCS548BBCRE	Swivel base external bracket coupling	4.5	9.92

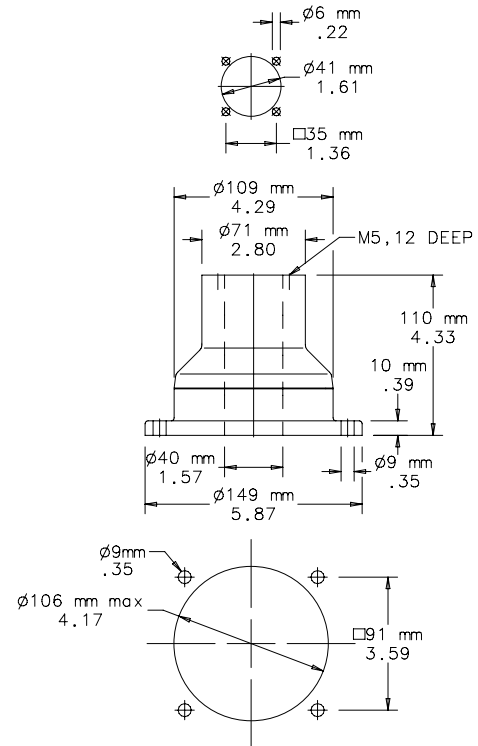

87799229

NOTE: Recommended mounting hole size shown.

### SWIVEL BASE INTERNAL BRACKET COUPLING



Swivel Base Internal Bracket Coupling for directly mounting enclosures to a machine or the floor. Turns through 340 degrees with rotation limiter. Preset torque. Maintenance-free bearings. Type 304 polished stainless steel finish. Includes gaskets and enclosure mounting hardware. Base-mounting fasteners not provided.

**BULLETIN: CCR6**



Catalog Number	Description	Product Weight (kg)	Product Weight (lb.)
CCSS48BBCRI	Swivel base internal bracket coupling	4.1	9.03

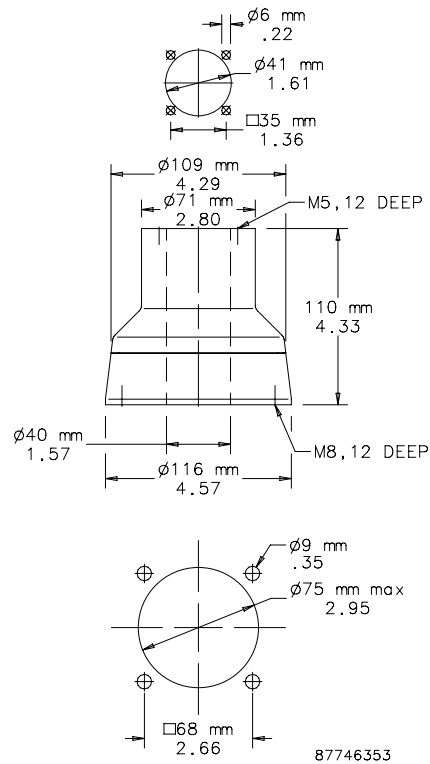

NOTE: Recommended mounting hole size shown.

### WALL JOINT



Wall Joint with vertical socket for mounting to vertical surfaces. Cover to facilitate wiring. Turns through 340 degrees with rotation limiter. Preset torque. Maintenance-free bearings. Type 304 polished stainless steel finish. Includes gaskets. Wall-mounting fasteners not provided.

**BULLETIN: CCR6**

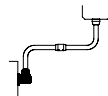

Catalog Number	Description	Product Weight (kg)	Product Weight (lb.)
CCSS48WJV	Wall joint, vertical mount	7.3	16.09

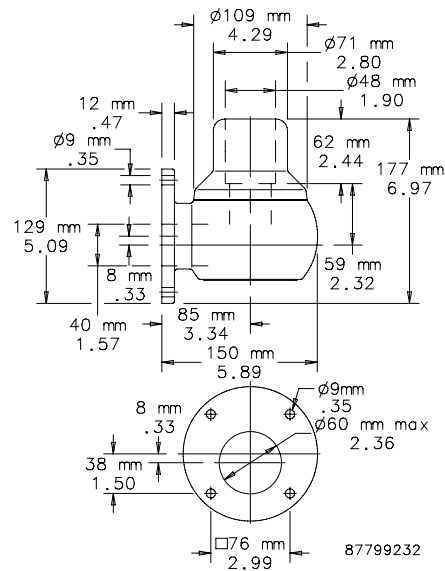

NOTE: Recommended mounting hole size shown.

**WALL COUPLING**

Swivel Wall Coupling for direct mounting of enclosure to vertical machine surfaces. Turns through 340 degrees with rotation limiter. Cover to facilitate wiring. Preset torque. Maintenance-free bearings. Type 304 polished stainless steel finish. Includes gaskets and enclosure mounting hardware. Wall-mounting fasteners not provided.

**BULLETIN: CCR6**



Catalog Number	Description	Product Weight (kg)	Product Weight (lb.)
CCSS48WJC	Wall coupling, vertical mount	7.3	16.09

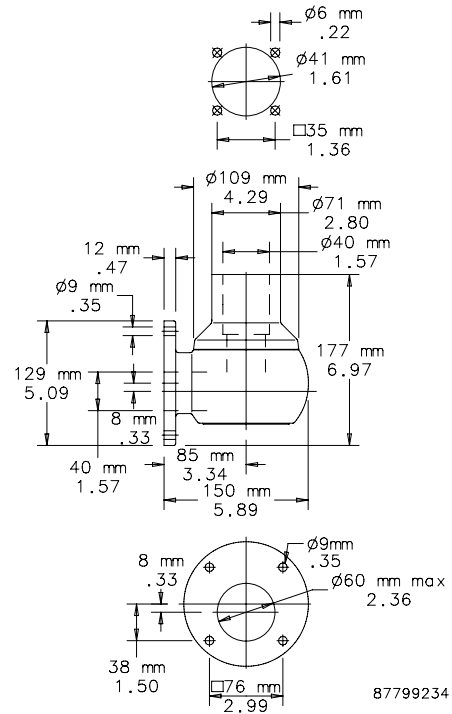

NOTE: Recommended mounting hole size shown.

**WALL BRACKET**

Wall Bracket with vertical socket for attachment to vertical surfaces. Cover to facilitate wiring. Type 304 polished stainless steel finish. Includes gaskets. Wall-mounting fasteners not included.

**BULLETIN: CCR6**



Catalog Number	Description	Product Weight (kg)	Product Weight (lb.)
CCSS48WJRV	Wall bracket	7.7	16.25

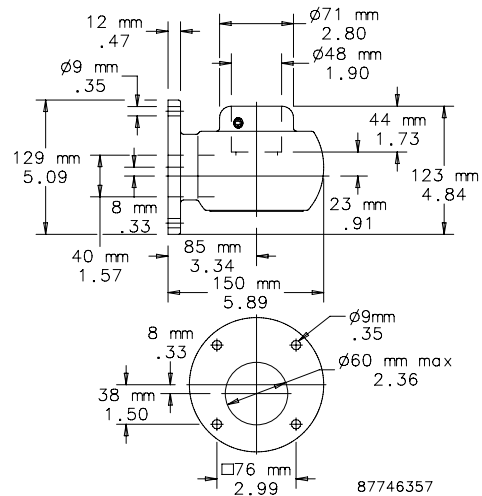

NOTE: Recommended mounting hole size shown.

## Notes