

## SLIDEWAYS

Hepco CM series slideways consist of high carbon steel precision profiles zone hardened on the V edges (typical hardness 55-60 HRC) with soft centre portion to enable customers to carry out extra drilling or machining if required. V bearing faces are etched to aid lubrication retention at the running surfaces. Slide fixing holes are accurately positioned, enabling customers to predrill their mounting holes. Slides may be ordered without holes for use with slide pivots and/or flange clamps if required (see pages 16 & 17).

**SPACER SLIDE (TYPE NC)** Bolts direct to customer's machine providing adequate running clearance for bearing assemblies and cap wipers. Datum registers are provided on the spacer portion of the slide for location against customer's machined datum edge if required.

**DOWEL PINS (TYPE SDP)** A central keyway is provided for simple location by means of Hepco stepped dowel pins if required. (Recommended positions: One each centrally between slide end and first hole. Also centrally between each pair of fixing holes.)

**FLAT SLIDE (TYPE C)** Designed for customers who prefer to bolt the slide to a rectangular spacer profile as part of their own machine construction. Where the slide is required to be the moving element an aluminium spacer plate can be constructed in order to reduce inertia.

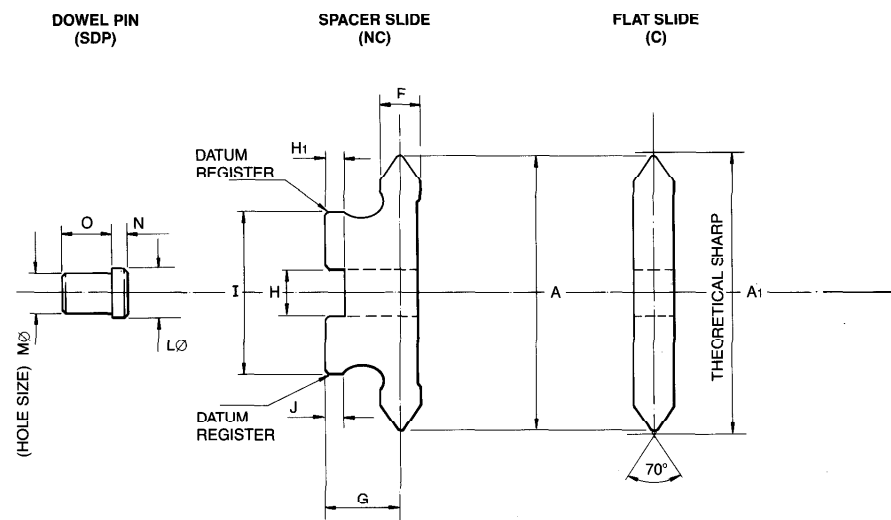

SLIDE TYPE	A	A1	MAXIMUM RECOMMENDED		MINIMUM		E	F	G	H	H <sup>1</sup>	I	J	K $\emptyset$	SCREW SIZE	MASS g/100mm	DOWEL OPTION (SDP)			
			C	D	C	D											L $\emptyset$	M $\emptyset$	N	O
	—	—	±1.5		±1.5		±0.2	—	—	+0.1 -0.0	+0.05 -0.0	—	+0.2 -0.0	—	—	—	m6	k6	+0.0 -0.3	—
<b>NC25</b>	25.5	26.58	43	✓	7	90	5	10.2	6	2.7	15.4	2.7	5.5	M5	155	6	4	2.25	6	
<b>C25</b>	25.5	26.58	43		7	90	5	—	—	—	—	—	5.5	M5	90	—	—	—	—	
<b>NC44</b>	44.5	45.58	43	✓	8	90	6.5	12.7	8	3.2	26.4	3.2	7.0	M6	350	8	6	2.75	8	
<b>C44</b>	44.5	45.58	43		8	90	6.5	—	—	—	—	—	7.0	M6	210	—	—	—	—	
<b>NC76</b>	76.5	77.58	88	✓	15	180	9.5	19.7	15	5.2	50.4	5.2	14.0	M12	995	15	10	4.75	15	
<b>C76</b>	76.5	77.58	43		13	90	9.5	—	—	—	—	—	11.5	M10	525	—	—	—	—	

ALL DIMENSIONS IN MM

**SLIDEWAYS**

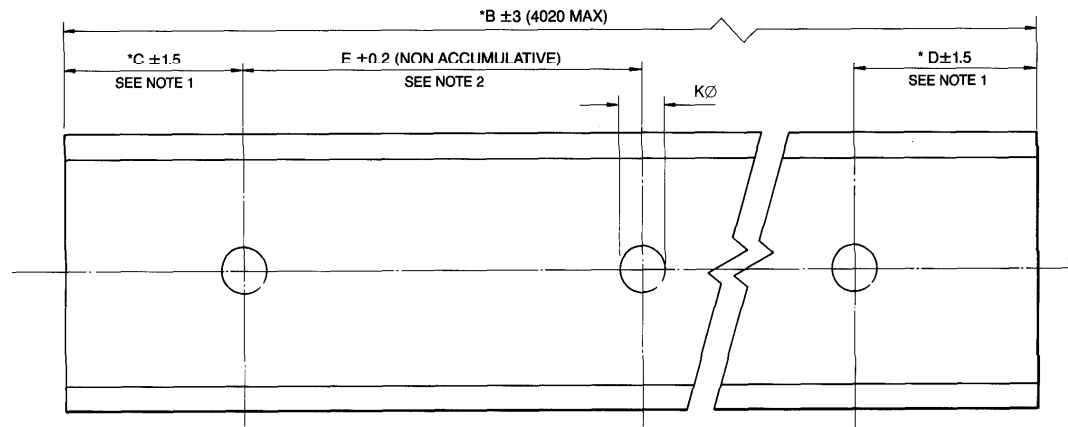
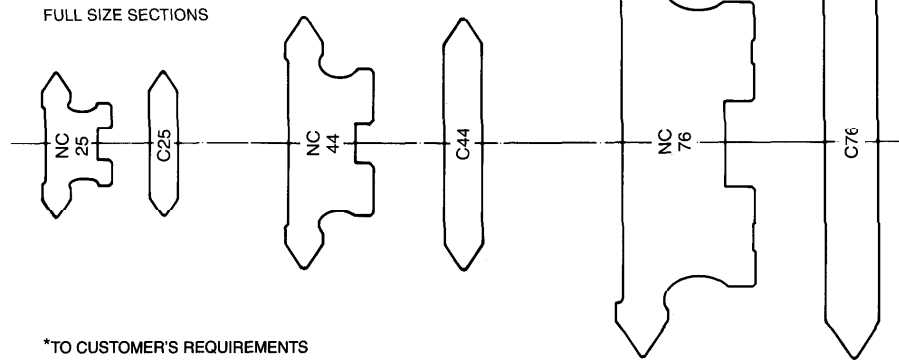

**NOTES:**

- 1 For optimum value and availability, customers should specify dimensions C & D to max recommended length per chart ensuring that remaining slide length is divisible by hole pitch E.
- 2 In special cases where the sum of customers specified dimensions B-(C+D) is not divisible by hole pitch E, the first and last hole pitches will be supplied to an equal, regulated length ( $\pm 0.75\text{mm}$ ).
- 3 Button socket head fixing screws ISO 7380 are recommended for customers constructing their own flat carriage plates. (See Note 2, page 8).

**ORDERING DETAILS**

**EXAMPLE:**

(NC) (C) 25 - B690 -(P)-C30-D30-(SDP x 9)

- DOWEL PIN (9 OFF)
- D DIMENSION
- C DIMENSION
- SLIDE REQUIRED WITHOUT HOLES
- LENGTH OF SLIDE 'B'
- NOMINAL WIDTH OF SLIDE
- FLAT SLIDE TYPE 'C'
- SPACER SLIDE TYPE 'NC'