

LOC	DIST	REVISIONS					
		P	LTR	DESCRIPTION	DATE	DWN	APVD
-	-		A	RELEASE	02APR2015	M.S	X.X
			AI	UPDATE TABLE	16APR2015	M.S	X.X

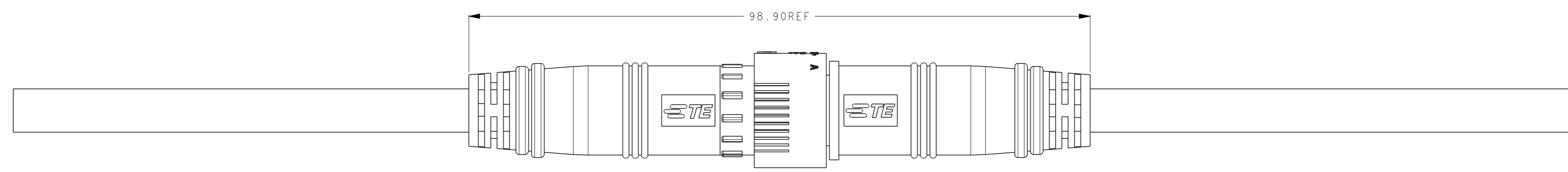
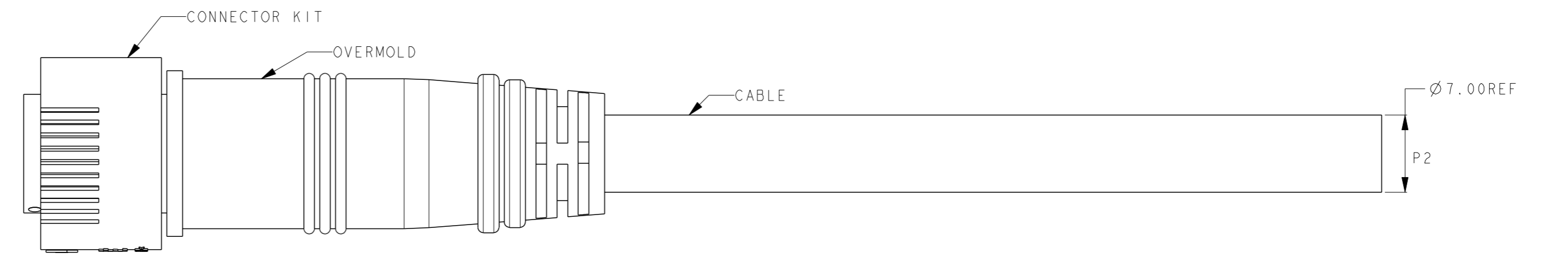
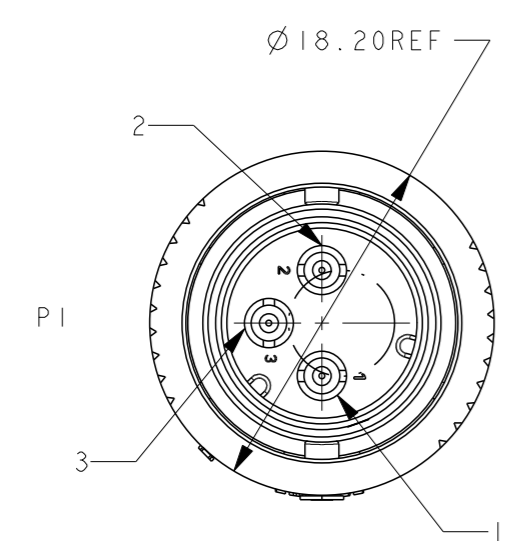

MATE WITH 2834003 SERIES

P1	WIRE COLOR	P2
PI-1	RED	-
PI-2	BLACK	-
PI-3	BROWN	-

NOTES:
 1. MATE WITH 2834003 SERIES.
 2. RATINGS:
 VOLTAGE: 300V AC/DC
 CURRENT: 6A MAX.
 TEMPERATURE: 80°C

P/N	CABLE	DIM A	L (mm)
9-2834002-1	RUBBER (THERMOPLASTIC ELASTOMER TYPE)	Ø 8.0	150±5
9-2834002-2			250±10
9-2834002-3			500±15
9-2834002-4			1000±15

THIS DRAWING IS A CONTROLLED DOCUMENT.		DWN SHI MING	10SEP2014	TE Connectivity	
DIMENSIONS: mm		CHK SHI MING	10SEP2014		
TOLERANCES UNLESS OTHERWISE SPECIFIED:		APVD XU XIANG	10SEP2014	NAME 3P MALE CABLE ASSEMBLY CIRCULAR LIGHTING SEALED CONN.	
0 PLC ±- 1 PLC ±1.0 2 PLC ±0.5 3 PLC ±- 4 PLC ±- ANGLES ±- FINISH ±-		PRODUCT SPEC 108-137041		RESTRICTED TO	
MATERIAL		APPLICATION SPEC 114-137041		SIZE A2	CAGE CODE -
		WEIGHT -		DRAWING NO C=2834002	
		Customer Drawing		SCALE NTS	SHEET 1 OF 2
				REV AI	

THIS DRAWING IS UNPUBLISHED. RELEASED FOR PUBLICATION 20
 © COPYRIGHT 20 BY - ALL RIGHTS RESERVED.

LOC		DIST		REVISIONS			
P	LTR	DESCRIPTION	DATE	DWN	APVD		
-	-	SEE SHEET 1	-	-	-		

1. PUT PIECES OF PARTS INTO THE PLASTIC BAG, AND SEALED WITH RUBBER BAND AS 1 BUNCH. 3. SEAL THE CARTON.

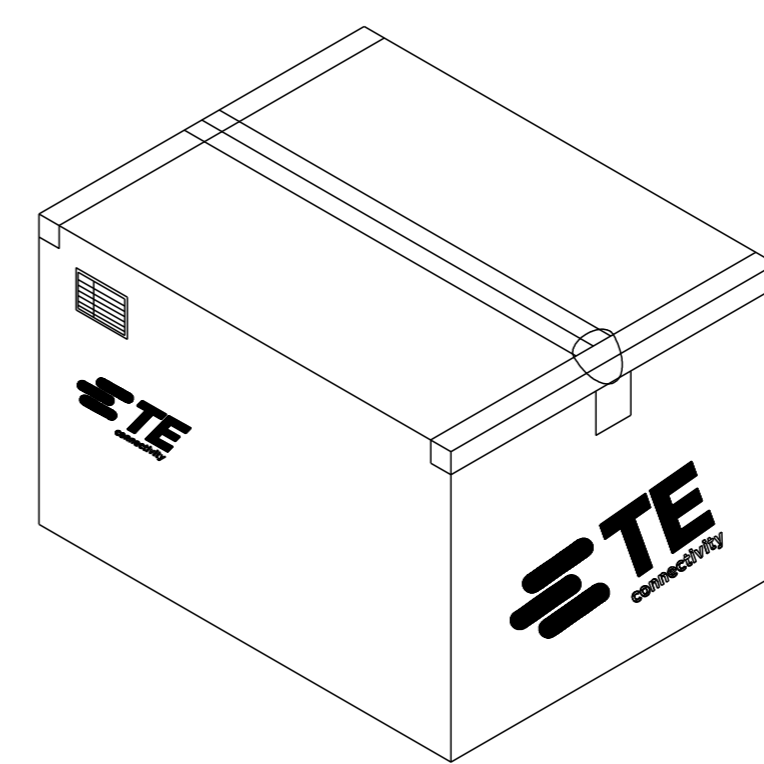
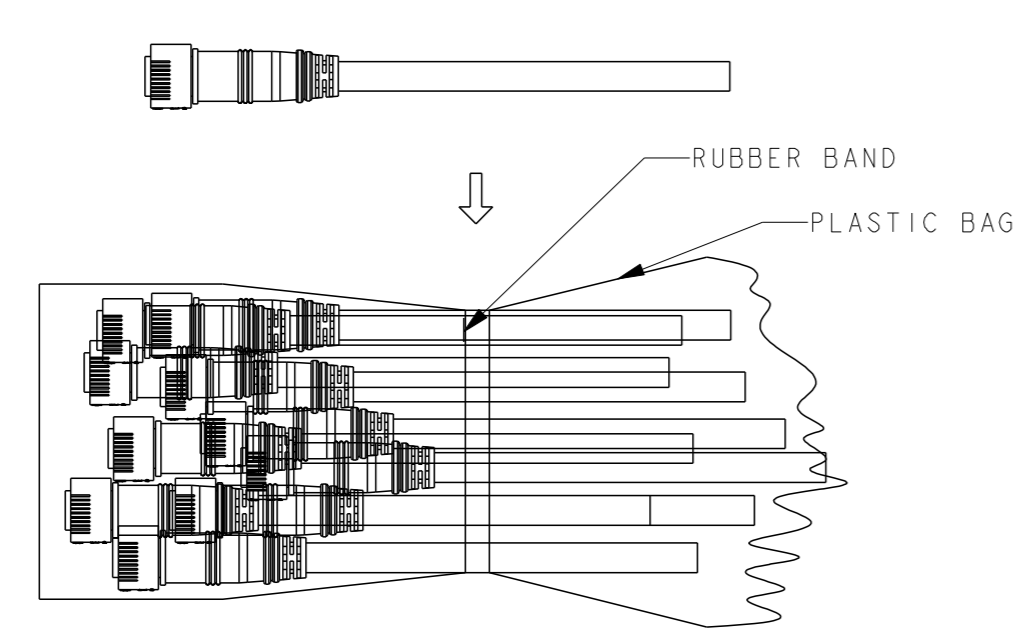

2. PUT BUNCHES OF PARTS INTO CARTON.

4. PACKAGING QUANTITIES(REFER SHEET 1 FOR PN DEFINITION):

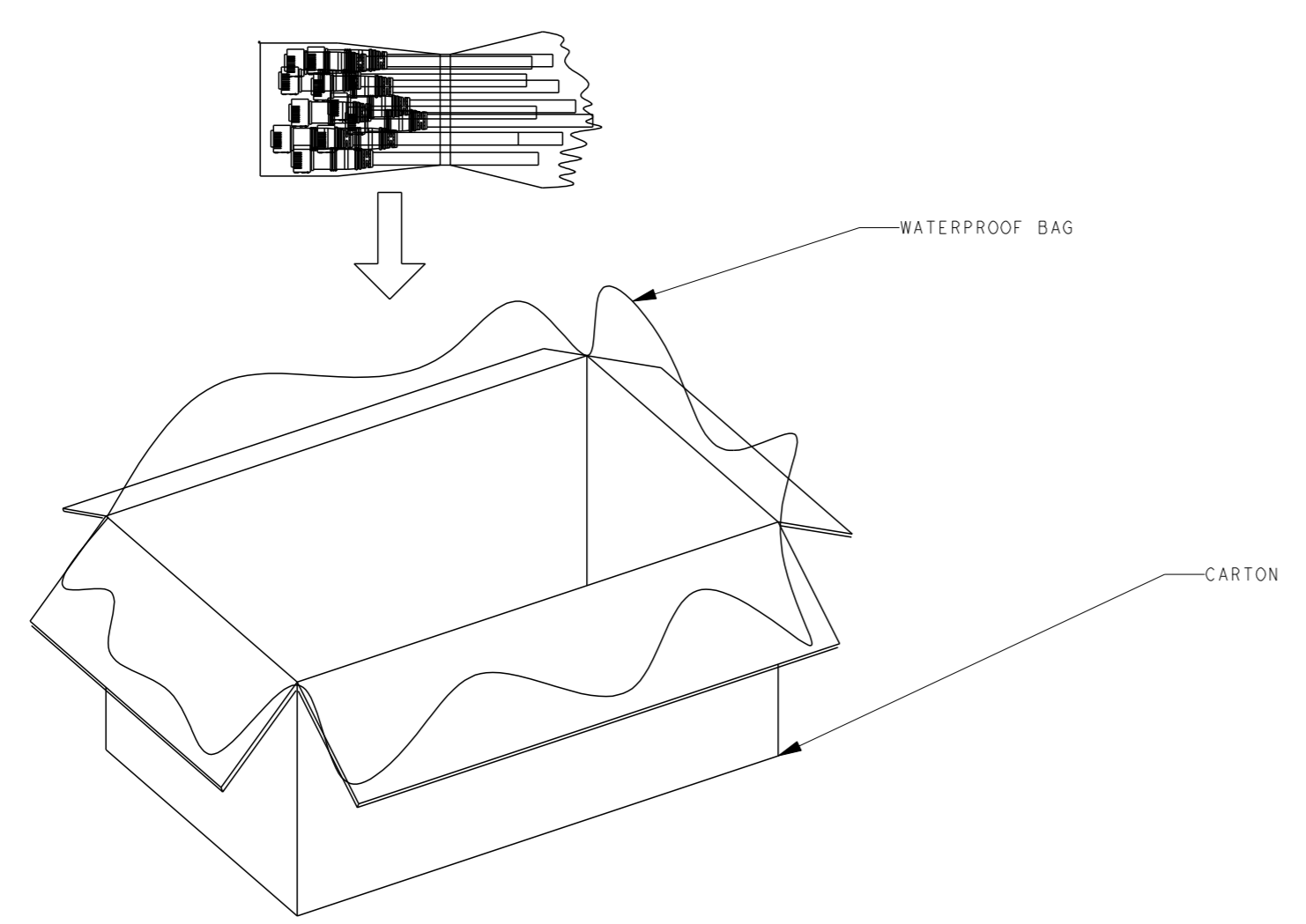

P/N	PARTS PER CARTON (PCS)
9-2834002-1	400
9-2834002-2	260
9-2834002-3	90
9-2834002-4	60

THIS DRAWING IS A CONTROLLED DOCUMENT.		DWN SHI MING 10SEP2014		
DIMENSIONS: mm		CHK SHI MING 10SEP2014		
TOLERANCES UNLESS OTHERWISE SPECIFIED:		APVD XU XIANG 10SEP2014	NAME 3P MALE CABLE ASSEMBLY CIRCULAR LIGHTING SEALED CONN.	
		PRODUCT SPEC 108-137041	RESTRICTED TO -	
MATERIAL -		APPLICATION SPEC 114-137041	SIZE A2	CAGE CODE -
		WEIGHT -	DRAWING NO C=2834002	
		Customer Drawing	SCALE NTS	SHEET 2 OF 2 REV AI