

P	LTR	DESCRIPTION	DATE	DWN	APVD
A4		REVISED PER ECO-11-005294	29APR2011	RK	HMR
A5		OBSOLETE PN 827551-6	17DEC2021	KMD	SCK
A6		E-24-226345	07NOV2024	SH	-

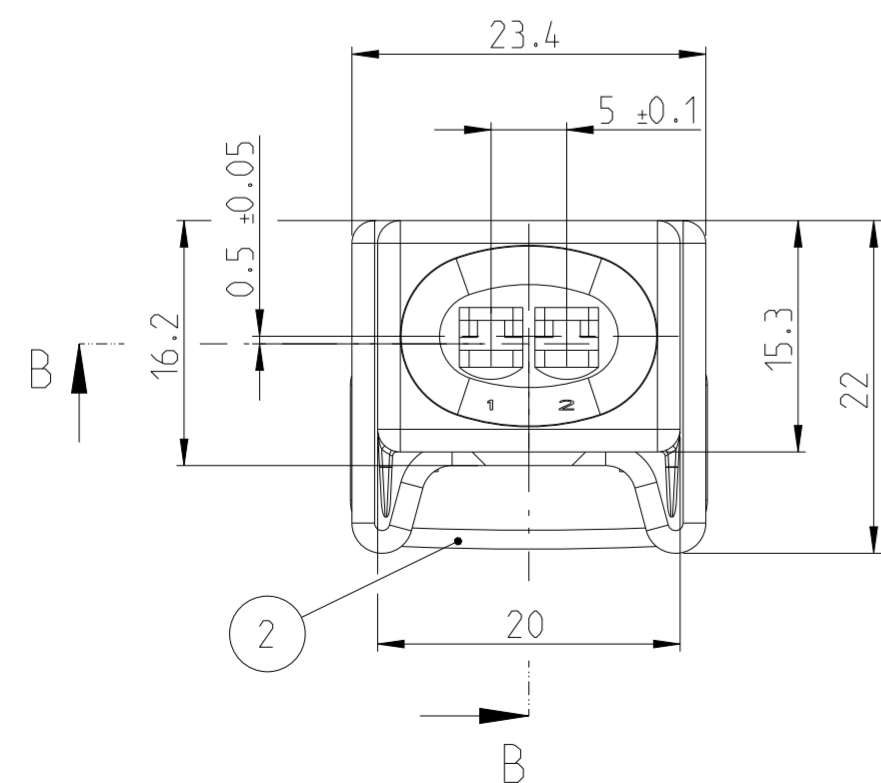
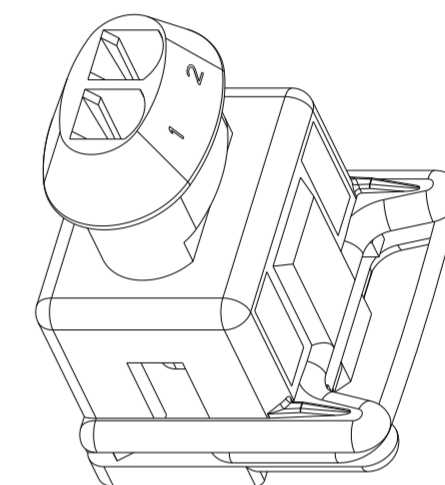
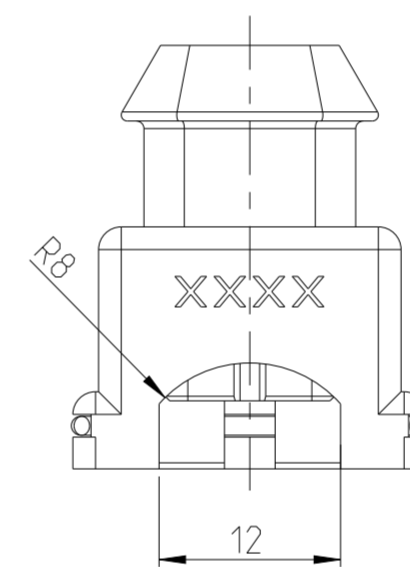
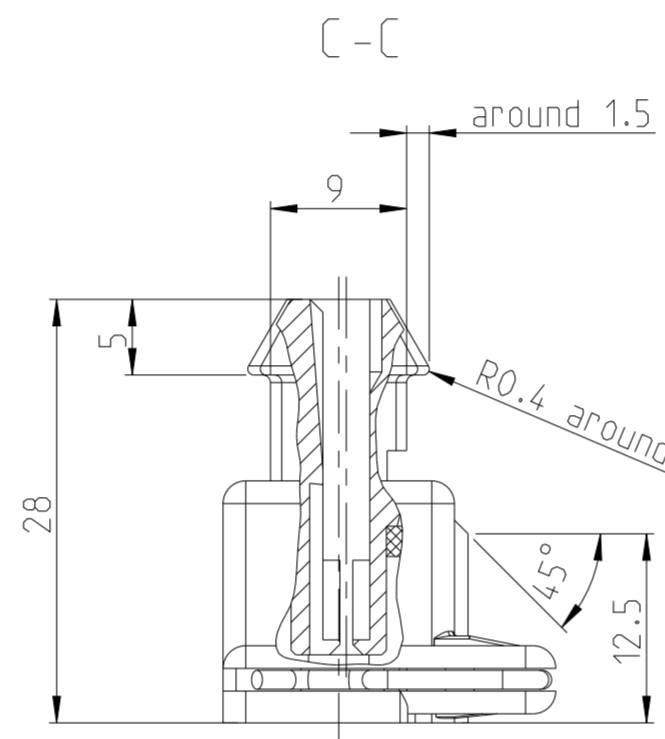
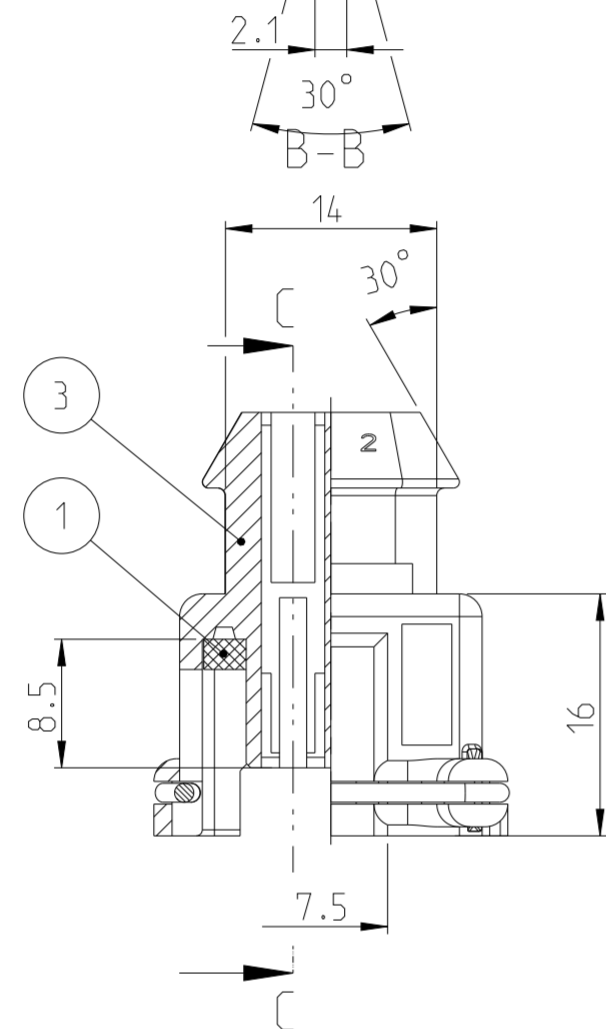
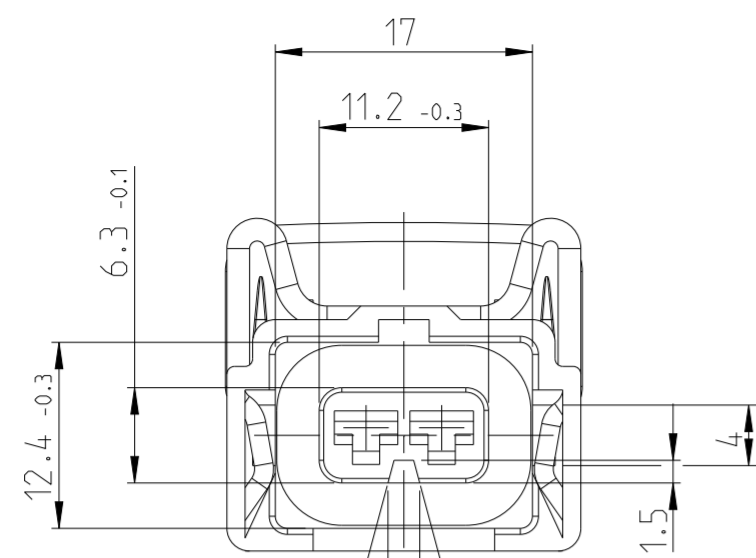

QTY	DESCRIPTION	ITEM NO.	MATERIAL	COLOR	
1	HOUSING	3	PA 6.6 GFV 30	YELLOW	
1	HOUSING	3		RED	
1	HOUSING	3		GREEN	
1	HOUSING	3		BLUE	
1	HOUSING	3		BROWN	
1	HOUSING	3		BLACK	
1	HOUSING	3		GREY	
1	HOUSING	3		NATURAL	
1	SPRING	2	DIN 2076		
1	SEALING	1	NEOPRENE		
827551-8					
827551-7					
827551-6					
827551-5					
827551-4					
827551-3					
827551-2					
827551-1					
	PART-NO.	DESCRIPTION	ITEM NO.	MATERIAL	COLOR

THIS DRAWING IS A CONTROLLED DOCUMENT.

DWN: Hoschek 12 JUL 1983
 CHK: Ryll 09 AUG 1983
 APVD: Bleicher M. 25 AUG 2006



DIMENSIONS:	TOLERANCES UNLESS OTHERWISE SPECIFIED:
mm	±0.3mm
	0-PLC ±0.1mm
	1-PLC ±0.1mm
	2-PLC ±0.1mm
	3-PLC ±0.1mm
	4-PLC ±0.1mm
	ANGLES ±2.5°
MATERIAL:	FINISH:
-	-

NAME:	ASSY FOR 2POS. HSG. FOR JUNIOR-TIMER CONTACT		
APPLICATION SPEC:	2 pol. Hehaeuse fuer Junior-Timer Kontakt		
SIZE:	CAGE CODE:	DRAWING NO:	RESTRICTED TO:
A2	00779	C-827551	-
CUSTOMER DRAWING	SCALE:	SHEET:	REV:
	2:1	1 OF 1	A6