

8BVP0440HC00.000-3

1 General information

- Wide input voltage range
- Regenerative
- Integrated connection for temperature sensor
- 2 slots for ACOPOSmulti plug-in modules

2 Order data

Order number	Short description	Figure
	Cold plate or feed-through mounting	
8BVP0440HC00.000-3	ACOPOSmulti3 power supply module, 44 A, AS, cold plate or pass-through mounting, optimized for applications with decentralized, computationally intensive open-loop and closed-loop control requirements	
	Required accessories	
	Terminal block sets	
8BZVP044000.000-1A	Screw clamp terminal block set for ACOPOSmulti 8BVP0220Hx00 and 8BVP0440Hx00 modules: 1x 8TB2106.2010-00, 1x 8TB2108.2010-00, 1x 8TB2104.204A-00, 1x 8TB4104.202L-10	
	Optional accessories	
	Accessory sets	
8BXB000.0000-00	ACOPOSmulti accessory set for encoder buffering consisting of: 1x battery AA 3.6 V, 1x protective cover for battery holder	
	Fan modules	
8BXF001.0000-00	ACOPOSmulti fan module, replacement fan for ACOPOSmulti modules (8BxP/8B0C/8BVI/8BVE/8B0K)	
	Plug-in modules	
8BAC0120.000-1	ACOPOSmulti plug-in module, EnDat 2.1 interface	
8BAC0120.001-2	ACOPOSmulti plug-in module, EnDat 2.2 interface	
8BAC0121.000-1	ACOPOSmulti plug-in module, HIPERFACE interface	
8BAC0122.000-1	ACOPOSmulti plug-in module, resolver interface 10 kHz	
8BAC0123.000-1	ACOPOSmulti plug-in module, incremental encoder and SSI absolute encoder interface for RS422 signals	
8BAC0123.001-1	ACOPOSmulti plug-in module, incremental encoder interface for 5 V single-ended and 5 V differential signals	
8BAC0123.002-1	ACOPOSmulti plug-in module, incremental encoder interface for 24 V single-ended and 24 V differential signals	
8BAC0124.000-1	ACOPOSmulti plug-in module, SinCos interface	
8BAC0125.000-1	ACOPOSmulti plug-in module, SinCos EnDat 2.1/SSI/BiSS interface	
8BAC0130.000-1	ACOPOSmulti plug-in module, 2 digital outputs, 50 mA, max. 62.5 kHz, 2 digital outputs, 500 mA, max. 1.25 kHz, 2 digital inputs 24 VDC	
8BAC0130.001-1	ACOPOSmulti plug-in module, 2 digital outputs, 50 mA, max. 62.5 kHz, 4 digital outputs, 500 mA, max 1.25 kHz	
8BAC0132.000-1	ACOPOSmulti plug-in module, 4 analog inputs ± 10 V	
8BAC0133.000-1	ACOPOSmulti plug-in module, 3 RS422 outputs for ABR encoder emulation, 1 MHz	
	POWERLINK/Ethernet cables	
X20CA0E61.00020	POWERLINK/Ethernet connection cable, RJ45 to RJ45, 0.2 m	
X20CA0E61.00025	POWERLINK/Ethernet connection cable, RJ45 to RJ45, 0.25 m	
X20CA0E61.00030	POWERLINK/Ethernet connection cable, RJ45 to RJ45, 0.3 m	
X20CA0E61.00035	POWERLINK/Ethernet connection cable, RJ45 to RJ45, 0.35 m	
X20CA0E61.00050	POWERLINK/Ethernet connection cable, RJ45 to RJ45, 0.5 m	
X20CA0E61.00100	POWERLINK/Ethernet connection cable, RJ45 to RJ45, 1 m	
	Shield component sets	
8SCS002.0000-00	ACOPOSmulti shield component set: 1x clamping plate, 2x clamp D 4-13.5 mm, 2x screws	
8SCS005.0000-00	ACOPOSmulti shield component set: 1x slot cover / shield plate	
8SCS007.0000-00	ACOPOSmulti shield component set: 1x shield mounting plate 2x 45°, 4x screws	
8SCS008.0000-00	ACOPOSmulti shield component set: 1x shield plate 2x type 0, 1x hose clamp, B 9 mm, D 23-35 mm	
8SCS010.0000-00	ACOPOSmulti shield component set: 1x ACOPOSmulti holding plate SK14-20, 1x shield connection clamp SK20	
	Terminal blocks	
8TB2104.204A-00	4-pin screw clamp terminal block, 1-row, pitch: 5.08 mm, label 4: T- T+ F- F+, coding A: 0000	
8TB2106.2010-00	6-pin screw clamp terminal block, 1-row, pitch: 5.08 mm, label 1: Numbered consecutively	
8TB2106.2210-00	Push-in terminal block 6-pin, 1-row, spacing: 5.08 mm, label 1: numbered consecutively	
8TB2108.2010-00	8-pin screw clamp terminal block, 1-row, pitch: 5.08 mm, label 1: Numbered consecutively	
8TB4104.202L-10	Screw clamp terminal block 4-pin, one-row, pitch: 10.16 mm, label 2: PE L3 L2 L1, coding L: 1010	

Table 1: 8BVP0440HC00.000-3 - Order data

3 Technical data

Order number	8BVP0440HC00.000-3
General information	
B&R ID code	0x2EE6
System requirements	
Automation Studio	4.6.1.x or later
Cooling and mounting type	Cold plate or pass-through mounting
Slots for plug-in modules	2
Certifications	
CE	Yes
UKCA	Yes
UL	cULus E225616
KC	Power conversion equipment
	Yes
Mains connection	
Network configurations	TT, TN-S, TN-C-S ¹⁾
Mains input voltage	3x 220 to 3x 480 VAC ±10%
Frequency	50 / 60 Hz ±4%
Installed load ²⁾	Max. 31.1 kW
Inrush current at 400 VAC	Max. 67 A
Switch-on interval ³⁾	>300 s
Max. chargeable DC bus capacitance depending on mains voltage	
230 VAC	17.4 mF
400 VAC	5.8 mF
480 VAC	4 mF
Nominal switching frequency	5 kHz
Possible switching frequencies ⁴⁾	5 / 10 kHz
Integrated line filter per EN 61800-3, category C3 ⁵⁾	No
Integrated regeneration choke	No
Regenerative	Yes
Power factor correction (PFC)	Yes
Variant	
L1, L2, L3, PE	Connector
PE	M5 threaded bolt
Shield connection ⁶⁾	Yes
Terminal connection cross section	
Flexible and fine-stranded wires	
With wire end sleeves	0.5 to 16 mm ²
Approbation data	
UL/C-UL-US	20 to 6 AWG
CSA	20 to 6 AWG
Terminal cable cross section dimension of shield connection	23 to 35 mm
DC bus connection	
Voltage	
Nominal	750 VDC
Continuous power (supply and regeneration) ⁷⁾	30 kW
Reduction of continuous power depending on mains input voltage	
Mains input voltage <3x 400 VAC	75 W/V * (400 V - Mains input voltage)
Reduction of continuous power depending on DC bus voltage (U _{DC})	
U _{DC} <750 VDC	$P * (1 - U_{DC}/750)$ ⁸⁾
Reduction of continuous power depending on switching frequency and mounting type ⁹⁾	
Switching frequency 5 kHz	
Cold plate mounting ¹⁰⁾	0.56 kW/K (starting at 45°C) ¹¹⁾
Pass-through mounting	In preparation
Switching frequency 10 kHz	
Cold plate mounting ¹⁰⁾	0.43 kW/K (starting at 6°C) ¹²⁾
Pass-through mounting	In preparation
Reduction of continuous power depending on installation elevation	
Starting at 500 m above sea level	3 kW per 1000 m
Peak power (supply and regeneration)	60 kW
Reduction of peak power depending on mains input voltage	
Mains input voltage <3x 400 VAC	150 W/V * (400 V - Mains input voltage)
Power dissipation depending on switching frequency ¹³⁾	
Switching frequency 5 kHz	$[0.15 * P^2 + 10.5 * P + 40]$ W
Switching frequency 10 kHz	$[0.42 * P^2 + 16 * P + 130]$ W

Table 2: 8BVP0440HC00.000-3 - Technical data

Order number	8BVP0440HC00.000-3
DC bus capacitance	825 µF
Protective measures	
Overload protection	Yes
Short-circuit and ground fault protection	No
Variant	ACOPOSmulti backplane
24 VDC power supply ¹⁴⁾	
Input voltage	25 VDC ±1.6%
Input capacitance	4.7 µF
Max. power consumption	27 W + P _{SLOT1} + P _{SLOT2} + P _{24 V Out} + P _{Fan8BVF...} ¹⁵⁾
Variant	ACOPOSmulti backplane
24 VDC Out	
Quantity	2
Output voltage	
DC bus voltage (U _{DC}): 260 to 315 VDC	25 VDC * (U _{DC} / 315)
DC bus voltage (U _{DC}): 315 to 800 VDC	24 VDC ±6%
Fuse protection	250 mA (slow-blow) electronic, automatic reset
Filter fan connection	
Output voltage	24 V +5.8% / -0.1%
Continuous current	4.2 A
Max. overcurrent limiting	10 A
Protective measures	
Overload protection	No
Short-circuit proof	Yes
Open-circuit monitoring	No
Undervoltage monitoring	No
Trigger inputs	
Quantity	2
Circuit	Sink
Electrical isolation	
Input - Power supply module	Yes
Input - Input	Yes
Input voltage	
Nominal	24 VDC
Maximum	30 VDC
Switching threshold	
Low	<5 V
High	>15 V
Input current at nominal voltage	Approx. 10 mA
Switching delay	
Rising edge	52 µs ±0.5 µs (digitally filtered)
Falling edge	53 µs ±0.5 µs (digitally filtered)
Modulation compared to ground potential	Max. ±38 V
Support	
Motion system	
mapp Motion	5.24.1 and higher
ACP10/ARNC0	5.24.1 and higher
Electrical properties	
Discharge capacitance	0.9 µF
Operating conditions	
Permissible mounting orientations	
Hanging vertically	Yes
Horizontal, face up	Yes
Standing horizontally	No
Installation elevation above sea level	
Nominal	0 to 500 m
Maximum ¹⁶⁾	4000 m
Pollution degree per EN 61800-5-1	2 (non-conductive pollution)
Overvoltage category per EN 61800-5-1	III
Degree of protection per EN 60529	IP20
Ambient conditions	
Temperature	
Operation	
Nominal	5 to 40°C
Maximum	55°C
Storage	-25 to 55°C
Transport	-25 to 70°C
Relative humidity	
Operation	5 to 85%
Storage	5 to 95%
Transport	Max. 95% at 40°C

Table 2: 8BVP0440HC00.000-3 - Technical data

Order number	8BVP0440HC00.000-3
Mechanical properties	
Dimensions ¹⁷⁾	
Width	106.5 mm
Height	317 mm
Depth	
Cold plate	212 mm
Pass-through mounting	209 mm
Weight	Approx. 4.5 kg
Module width	2

Table 2: 8BVP0440HC00.000-3 - Technical data

- 1) TT and TN power systems are commonly referred to as "Delta/Wye with grounded wye neutral" in the USA.
- 2) The specified value already includes the power dissipation of the associated 8BVF line filter and associated 8BVR regeneration choke.
- 3) At max. chargeable DC bus capacitance.
- 4) B&R recommends operating the module at its nominal switching frequency. Operating the module at a higher switching frequency for application-specific reasons reduces the continuous power and increases CPU utilization.
- 5) Limit values from EN 61800-3 C3 (second environment).
- 6) Cables do not have to be shielded up to a total wiring length of 3 m between the line filter, regeneration choke and power supply module. Consult B&R when using cable lengths >3 m.
- 7) Valid under the following conditions: Mains input voltage 3x 400 VAC, nominal DC bus voltage 750 VDC, switching frequency 5 kHz, 40°C ambient temperature, installation elevation <500 m above sea level, no derating due to cooling type.
- 8) P ... Actual continuous power available (value adapted to actual ambient conditions)
- 9) Valid under the following conditions: 750 VDC DC bus voltage, minimum permissible coolant flow volume (3 l/min).
- 10) The temperature specifications refer to the return temperature of the cold plate mounting plate.
- 11) Value for the nominal switching frequency.
- 12) The module cannot supply the full continuous current at this switching frequency. This unusual value for the return temperature, at which derating of the continuous current must be taken into account, ensures that the derating of the continuous current can be determined in the same manner as at other switching frequencies.
Caution! Condensation can occur at low flow temperatures and return temperatures.
- 13) Valid for a mains input voltage of 400 VAC and a DC bus voltage of 750 VDC. P ... Continuous power [kW].
- 14) A power supply unit is integrated in the power supply modules for the electronics power supply. The power supply for the +24 VDC of the trigger inputs and the encoder power supplies on the encoder modules are fed from the 24 VDC power supply on the ACOPOSmulti backplane. As soon as the drive system has started up, the electronics power supply is taken over by a +24 VDC 8B0C auxiliary supply module.
- 15) P_{SLOT1} ... Max. power consumption P_{8BAC} [W] of the plug-in module in SLOT1 (see the technical data for the respective plug-in module).
P_{SLOT2} ... Max. power consumption P_{8BAC} [W] of the plug-in module in SLOT2 (see the technical data for the respective plug-in module).
P_{24 V Out} ... Power [W] that is output to connections X2/+24 V Out 1 and X2/+24 V Out 2 on the module (max. 10 W).
P_{Fan8BVF...} ... Power [W] that is output to connections X4A/F- and X4A/F+ of the module (see the technical data of the respective 8BVF... mains filter).
- 16) Continuous operation at an installation elevation of 500 m to 4,000 m above sea level is possible taking the specified reduction of continuous current into account. Requirements that go beyond this must be arranged with B&R.
- 17) These dimensions refer to the actual device dimensions including the respective mounting plate. Additional spacing above and below the devices must be taken into account for mounting, connections and air circulation.

4 Status indicators

Status indicators are located on the black cover of each module.

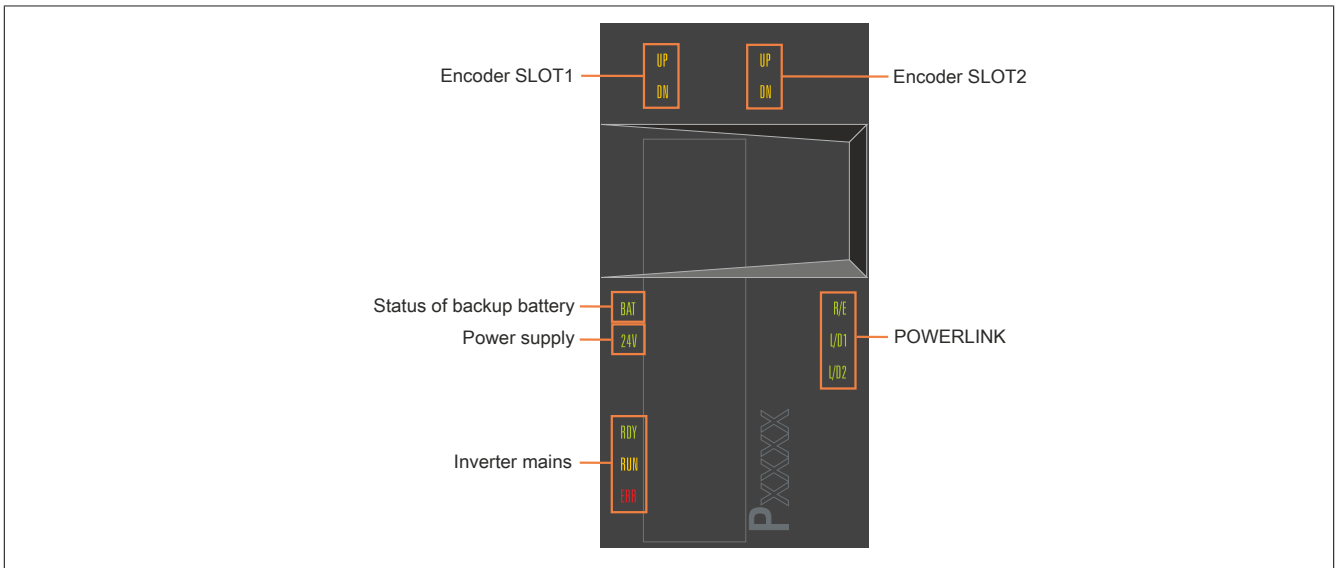

Figure 1: 8BVP power supply modules - Status indicator groups¹⁾

4.1 LED status indicators

Status indicator group	Label	Color	Function	Description
POWERLINK	R/E	Green/Red	Ready/Error	see "POWERLINK - LED status indicators" on page 7
	L/D1	Green	Link/Data activity on port 1	
	L/D2	Green	Link/Data activity on port 2	
Inverter mains	RDY	Green	Ready	see "RDY, RUN, ERR (8BVI, 8BVP, 8B0P) - LED status indicators" on page 7
	RUN	Orange	Run	
	ERR	Red	Error	
Status of backup battery ¹⁾	BAT	Green/Red	Ready/Error	see "Backup battery - LED status indicators" on page 8
Power supply	24 V	Green	24 V OK	24 V internal system power supply is within the tolerance range.
Encoder SLOT1	UP	Orange	Encoder direction of rotation +	The encoder position of the connected encoder is changing in the positive direction. The faster the encoder position changes, the brighter the LED lights up.
	DN	Orange	Encoder direction of rotation -	
Encoder SLOT2	UP	Orange	Encoder direction of rotation +	See encoder SLOT1.
	DN	Orange	Encoder direction of rotation -	

Table 3: 8BVP power supply modules - LED status indicators

- 1) Status indicator group "Backup battery status" is only available for modules with an integrated battery holder. Starting with a certain revision, the integrated battery holder is not included and using accessory kit 8BXB000.0000-00 (battery for encoder buffering) is no longer possible. For details, see the revision information of the respective module (www.br-automation.com).

4.2 RDY, RUN, ERR (8BVI, 8BVP, 8B0P) - LED status indicators

Label	Color	Function	Description	
RDY	Green	Ready	Solid green	The module is ready for operation and the power stage can be enabled (operating system present and booted, no pending permanent or temporary errors).
			Blinking green ¹⁾	The module is not ready for operation. Examples: <ul style="list-style-type: none"> No signal on one or both enable inputs DC bus voltage outside the tolerance range Overtemperature on the motor (temperature sensor) Motor feedback not connected or defective Motor temperature sensor not connected or defective Overtemperature on the module (IGBT junction, heat sink, etc.) Disturbance on network
RUN	Orange	Run	Solid orange	The module's power stage is enabled.
ERR	Red	Error	Solid red ¹⁾	There is a permanent error on the module. Examples: <ul style="list-style-type: none"> Permanent overcurrent Data in EPROM not valid
			Blinking red	<ul style="list-style-type: none"> LED status "Status changes when starting up the operating system loader" on page 8

Table 4: RDY, RUN, ERR (8BVI, 8BVP, 8B0P) - LED status indicators

1) Firmware V2.130 and later.

Information:

The ACOPOSmulti drive system has no way of detecting whether the module's internal fans are actually rotating.

4.3 POWERLINK - LED status indicators

Label	Color	Function	Description	
R/E	Green/Red	Ready/Error	LED off	The module is not supplied with power or network interface initialization has failed.
			Solid red	The POWERLINK node number of the module is 0.
			Blinking red/green	The client is in an error state (drops out of cyclic operation).
			Blinking green (1x)	The client detects a valid POWERLINK frame on the network.
			Blinking green (2x)	Cyclic operation on the network, but the client itself is not yet in cyclic operation.
			Blinking green (3x)	Cyclic operation of the client is in preparation.
			Solid green	The client is in cyclic operation.
			Flickering green	The client is not in cyclic operation and also does not detect any other stations on the network in cyclic operation.
L/D1	Green	Link/Data activity Port 1	Solid green	A physical connection has been established to another station on the network.
			Blinking green	Activity on port 1
L/D2	Green	Link/Data activity Port 2	Solid green	A physical connection has been established to another station on the network.
			Blinking green	Activity on port 2

Table 5: POWERLINK - LED status indicators

4.4 Backup battery - LED status indicators

Label	Color	Function	Description
BAT ¹⁾	Green/Red	Ready/Error	LED off
			Solid green
			Solid red

Possible causes:	
• The voltage of the installed backup battery is within the tolerance range, but an EnDat encoder with battery backup is not connected.	
• An EnDat encoder with backup battery is connected and registering "Battery OK", but the module's firmware version does not support EnDat encoders with battery backup.	

Possible causes:	
• Voltage of the installed backup battery outside of tolerance range	
• No backup battery installed in module	

Table 6: Backup battery - LED status indicators

1) Status indicator group "Backup battery status" is only available for modules with an integrated battery holder. Starting with a certain revision, the integrated battery holder is not included and using accessory kit 8BXB000.0000-00 (battery for encoder buffering) is no longer possible. For details, see the revision information of the respective module (www.br-automation.com).

4.5 Status changes when starting up the operating system loader

The following intervals are used for the LED status indicators:

Width of box: 50 ms

Repeats after: 3,000 ms

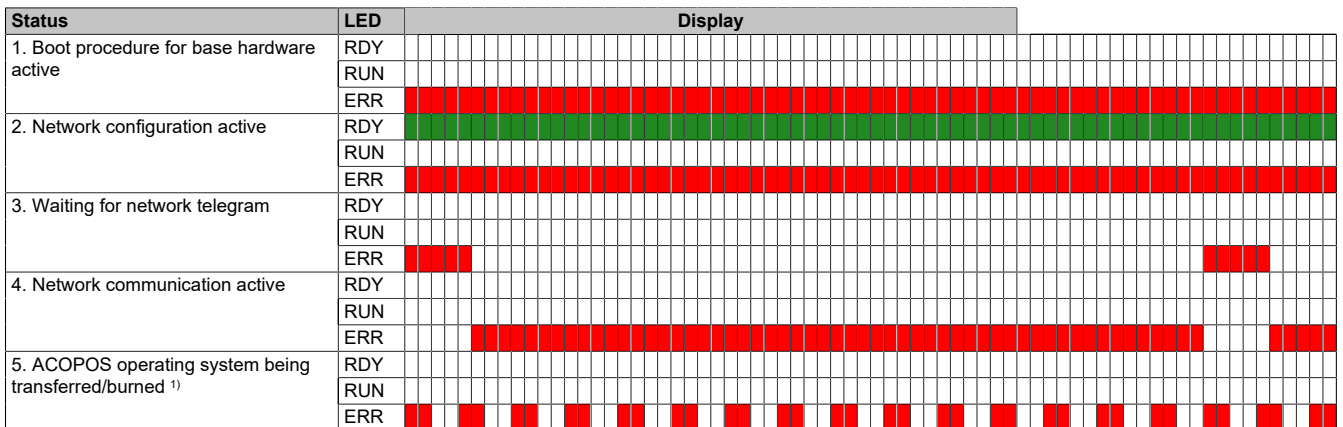
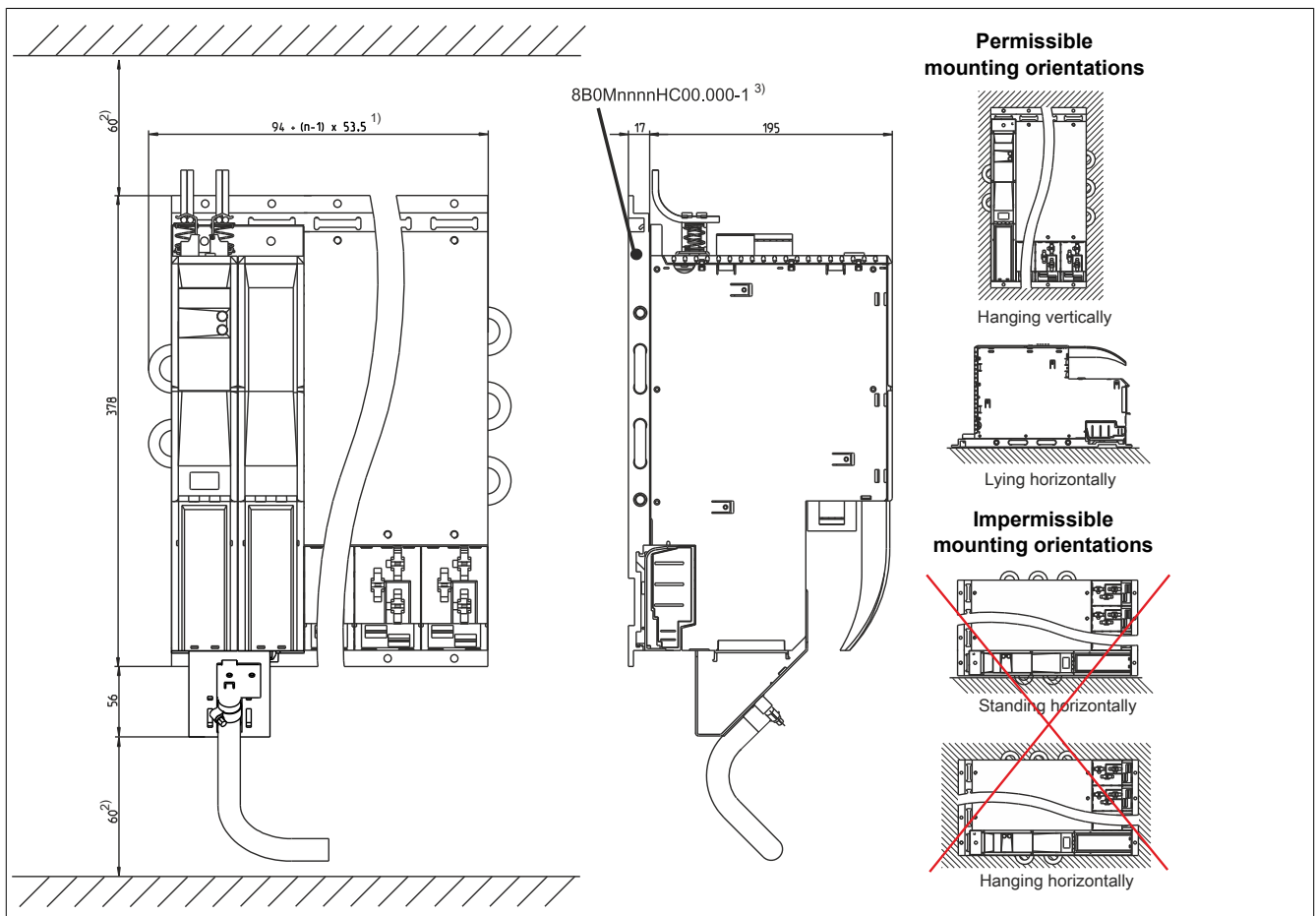

Table 7: Status changes when starting up the operating system loader

1) Firmware V2.140 and later.

5 Dimension diagram and installation dimensions

5.1 Cold plate



- 1) n... Number of width units on the mounting plate
- 2) For sufficient air circulation, a clearance of at least 60 mm must be provided above the mounting plate and below the module.
- 3) nnnn indicates the number of slots (e.g. 0160 refers to 16 slots).

Information:

When installing ACOPOSmulti modules with cold plate or pass-through mounting, it is important to ensure that the rear panel of the control cabinet is not scratched. This results in deterioration of the heat dissipation to the mounting plate.

Do not place ACOPOSmulti modules on their bottom side for cold plate or pass-through mounting. Doing so could break the clips that hold the unit to the fan. Broken clips make it more difficult to replace the fans later on.

5.2 Feed-through mounting

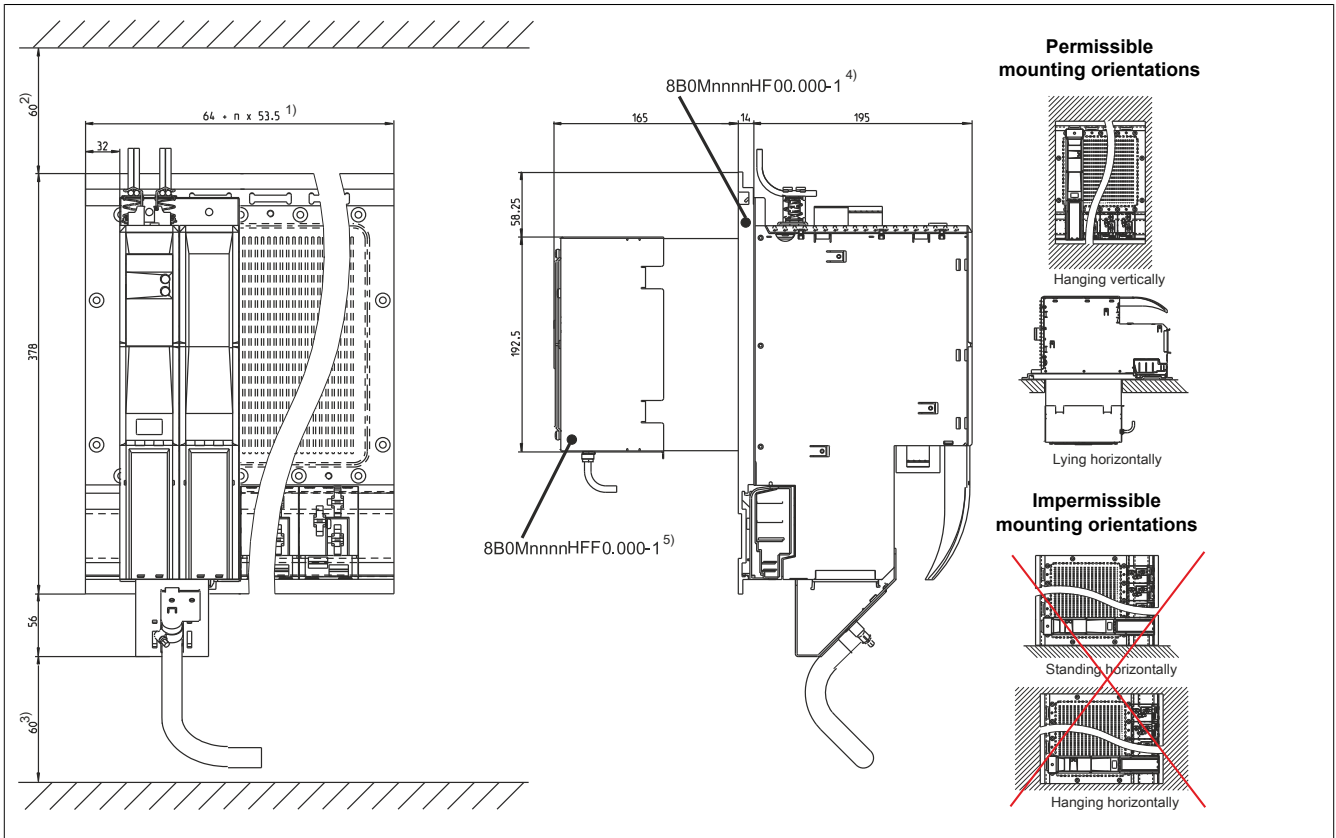

Figure 3: Feed-through mounting - Dimension diagram and installation dimensions

- 1) n... Number of width units on the mounting plate
- 2) For sufficient air circulation, a clearance of at least 60 mm must be provided above the mounting plate and below the module.
- 3) The required spacing to the wiring on the bottom of the module depends on the power cable being used.
- 4) nnnn indicates the number of slots (e.g. 0160 refers to 16 slots).
- 5) For sufficient air circulation, a clearance of at least 100 mm must be provided around the fan module.

Information:

When installing ACOPOSmulti modules with cold plate or pass-through mounting, it is important to ensure that the rear panel of the control cabinet is not scratched. This results in deterioration of the heat dissipation to the mounting plate.

Do not place ACOPOSmulti modules on their bottom side for cold plate or pass-through mounting. Doing so could break the clips that hold the unit is fan. Broken clips make it more difficult to replace the fans later on.

6 Wiring

6.1 8BVP0220Hx00.000-1, 8BVP0440Hx00.000-1 - Pinout overview

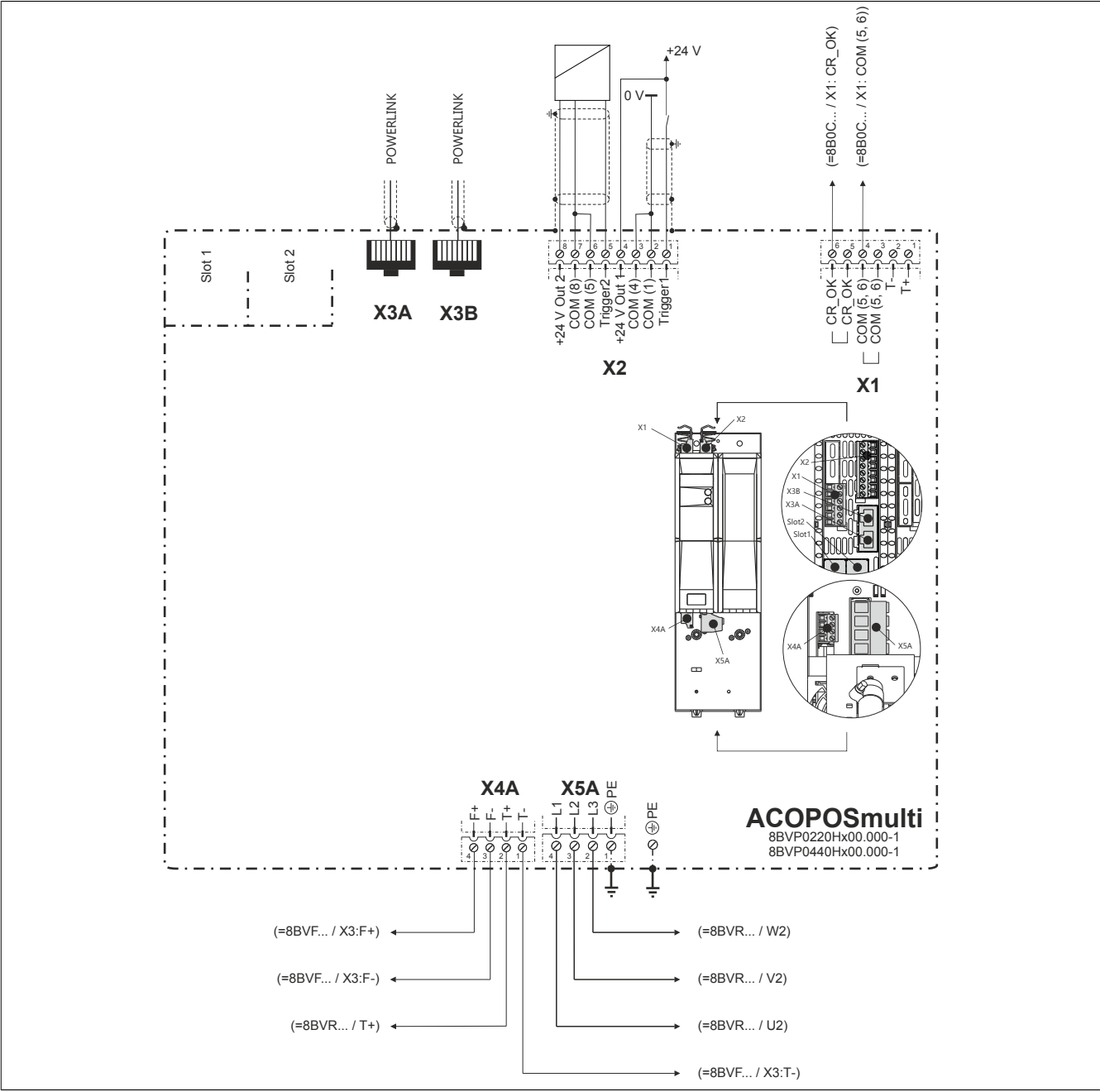

Figure 4: 8BVP0220Hx00.000-1, 8BVP0440Hx00.000-1 - Pinout overview

6.2 Connector X1 - Pinout

X1	Pin	Name	Function
 8TB2106.2010-00	1	T+	Temperature sensor +
	2	T-	Temperature sensor -
	3	COM (5, 6)	DC bus ready 0 V
	4	COM (5, 6)	DC bus ready 0 V
	5	CR_OK	DC bus ready ¹⁾
	6	CR_OK	DC bus ready ¹⁾

Table 8: Connector X1 - Pinout

- 1) Output CR_OK is only set if the following condition is met:
Charging relay is closed and DC bus voltage $U_{DC} > 270$ VDC.

Danger!

The connections for the temperature sensor are isolated circuits. As a result, only devices or components that have at least safe isolation per IEC 60364-4-41 or EN 61800-5-1 are permitted to be connected to these connections.

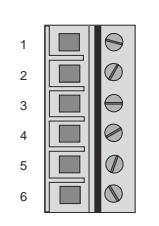
6.3 Connector X2 - Pinout

X2	Pin	Name	Function
 8TB2108.2010-00	1	Trigger1	Trigger1
	2	COM (1)	Trigger 1 0 V
	3	COM (4)	+24 V output 1 0 V
	4	+24 V Out 1	+24 V output 1
	5	Trigger2	Trigger2
	6	COM (5)	Trigger 2 0 V
	7	COM (8)	+24 V output 2 0 V
	8	+24 V Out 2	+24 V output 2

Table 9: Connector X2 - Pinout

6.4 Connectors X3A, X3B - Pinout

X3A, X3B	Pin	Name	Function
 1	1	RXD	Receive signal
	2	RXD\	Receive signal inverted
	3	TXD	Transmit signal
	4	Shield	Shield
	5	Shield	Shield
	6	TXD\	Transmit signal inverted
	7	Shield	Shield
	8	Shield	Shield

Table 10: X3A, X3B connectors - Pinout

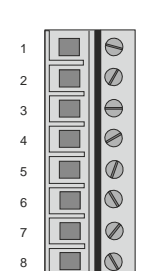
6.5 Connector X4A - Pinout

X4A	Name	Function
 8TB2104.204A-00	T-	Mains: Temperature sensor -
	T+	Mains: Temperature sensor +
	F-	Mains: Fan -
	F+	Mains: Fan +

Table 11: Connector X4A - Pinout

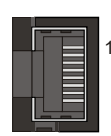
Danger!

The connections for the temperature sensor and fan are safely isolated circuits. As a result, only devices or components that have at least safe isolation per IEC 60364-4-41 or EN 61800-5-1 are permitted to be connected to these connections.

Warning!

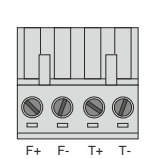
Connectors X4A/T+ and X4A/T- are mandatory for wiring temperature sensors of modules 8BVF and 8BVR. Using temperature sensor connectors of plug-in modules connected to SLOT1 is therefore not permitted!

6.6 Connector X5A - Pinout

X5A	Description	Function
 <p>8TB4104.202L-10</p>	PE	Power system: Protective ground conductor
	L3	Power system: Mains connection L3
	L2	Power system: Mains connection L2
	L1	Power system: Mains connection L1

Table 12: Connector X5A - Pinout

Danger!

Before switching on the module, it is important to make sure that the housing is properly connected to ground (PE rail). Ground connections must also be established if the module is connected for test purposes or only being operated for a short period of time!

6.7 Additional protective ground connection (PE)

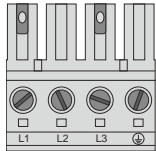
The protective ground conductor is secured to the M5 threaded bolt provided for this purpose using a cable lug.

Figure	Pin	Description	Function
	---	PE	Protective ground conductor
Terminal cross section		[mm²]	AWG
Cable lug for M5 threaded bolt		0.25 - 16	23 - 5

Table 13: Additional protective ground connection (PE)

Danger!

Before switching on the power supply, it must be ensured that the housing of the 8BVP power supply module is properly connected to ground potential (PE rail). Ground connections must also be established if the 8BVP power supply module is connected for test purposes or only being operated for a short period of time!

6.8 Input/Output circuit diagram

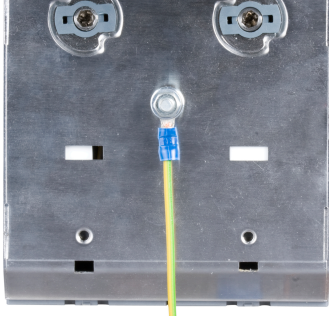
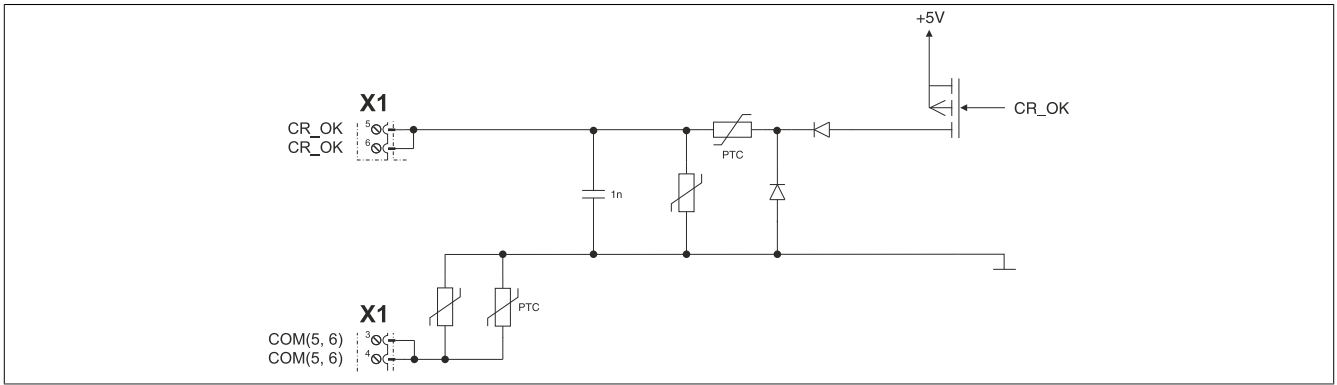

Figure 5: 8B0C - Enable

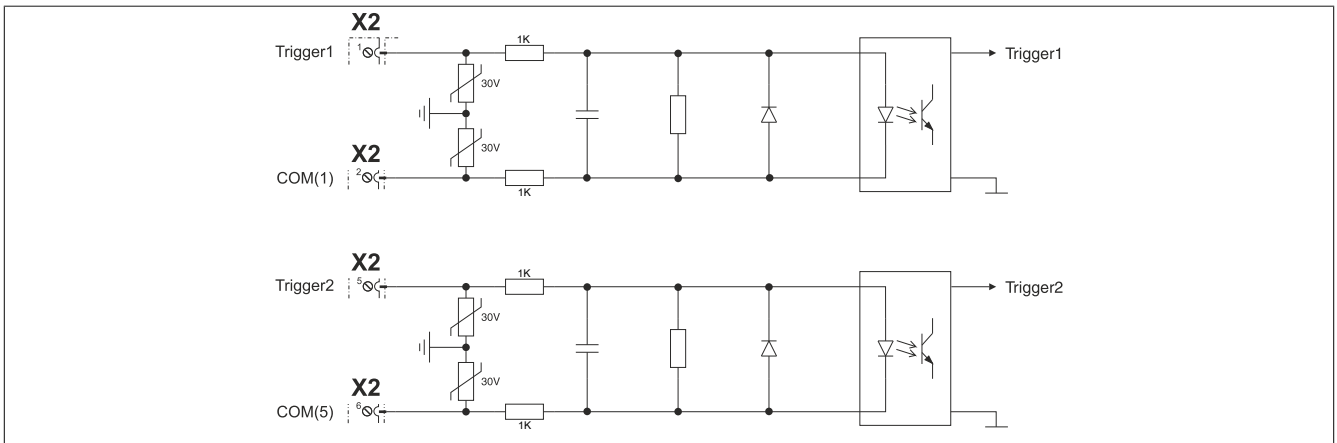

Figure 6: Trigger inputs

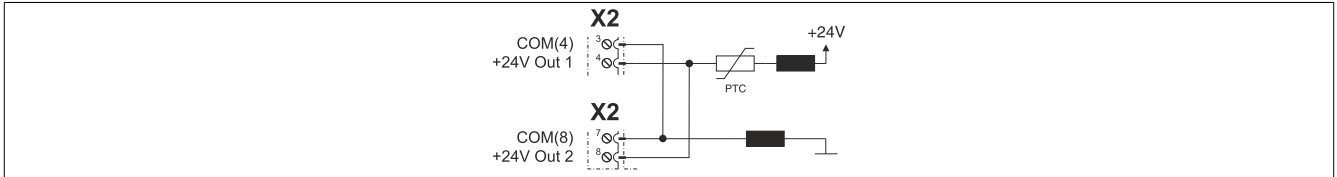

Figure 7: 24 VDC out

8BVP0220Hx00.000-1 ≥ Rev. H0
 8BVP0440Hx00.000-1 ≥ Rev. L0
 8BVP0880Hx00.00x-1 ≥ Rev. D0
 8BVP1650Hx00.00x-1 ≥ Rev. C0

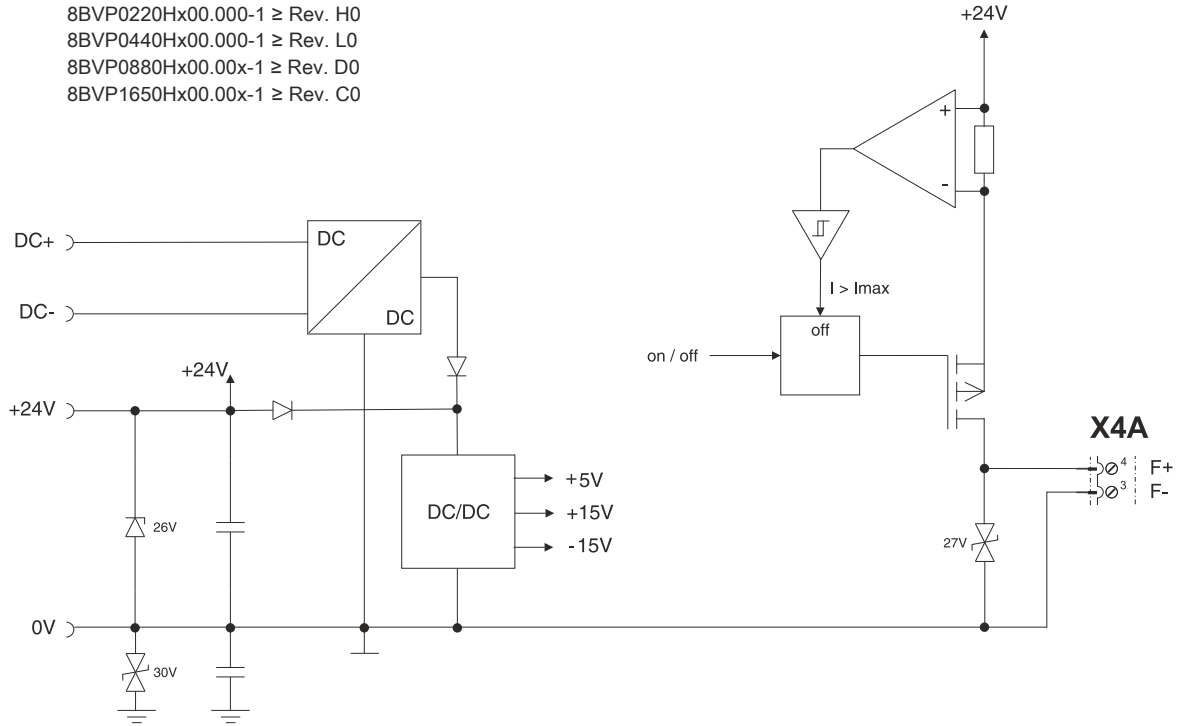

Figure 8: 8BVF fan - Control

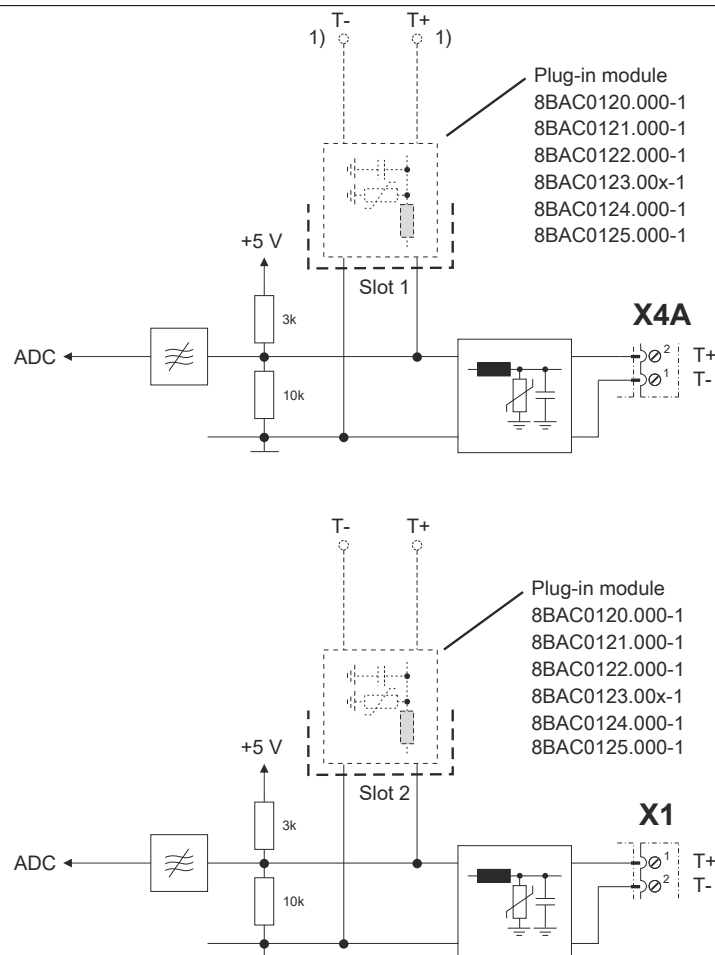

Figure 9: Temperature sensor

1) The temperature sensor connectors on the plug-in module in SLOT 1 are not permitted to be used!

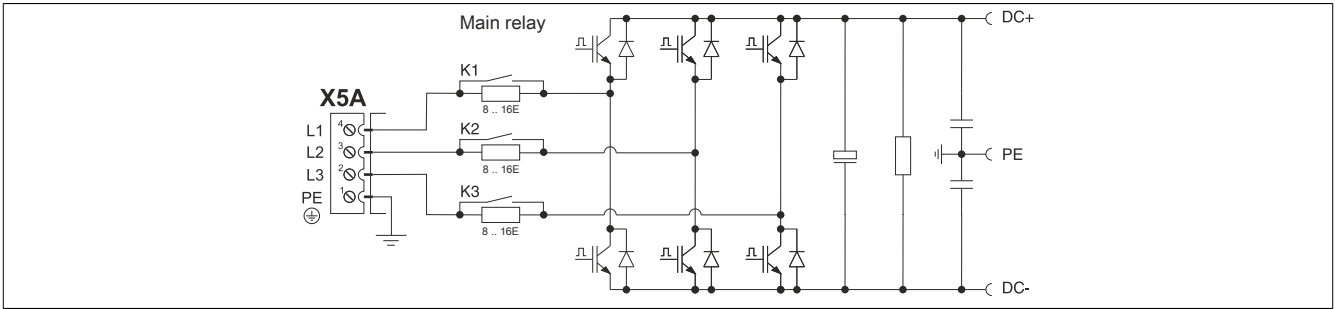

Figure 10: Power unit

6.9 POWERLINK node number setting

The POWERLINK node number can be set using the two hexadecimal coded rotary switches located behind the module's black cover:

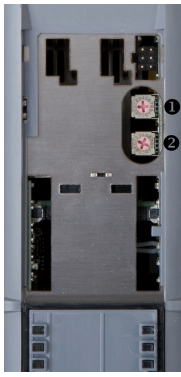
Figure		Coded rotary switches	POWERLINK node number
 <p>Cover closed</p>	 <p>Cover open</p>	1	16s position (high)
		2	1s position (low)
<p>A change to the POWERLINK node number only takes effect the next time the ACOPOSmulti drive system is switched on.</p> <p>Information:</p> <p>In principle, node numbers between \$01 and \$FD are permitted. However, node numbers between \$F0 and \$FD are intended for future system expansions. To ensure compatibility, these node numbers should be avoided.</p> <p>Node numbers \$00, \$FE and \$FF are reserved and are therefore not permitted to be set.</p>			

Table 14: Setting the POWERLINK node number