

### Shield/Strain Relief Kit

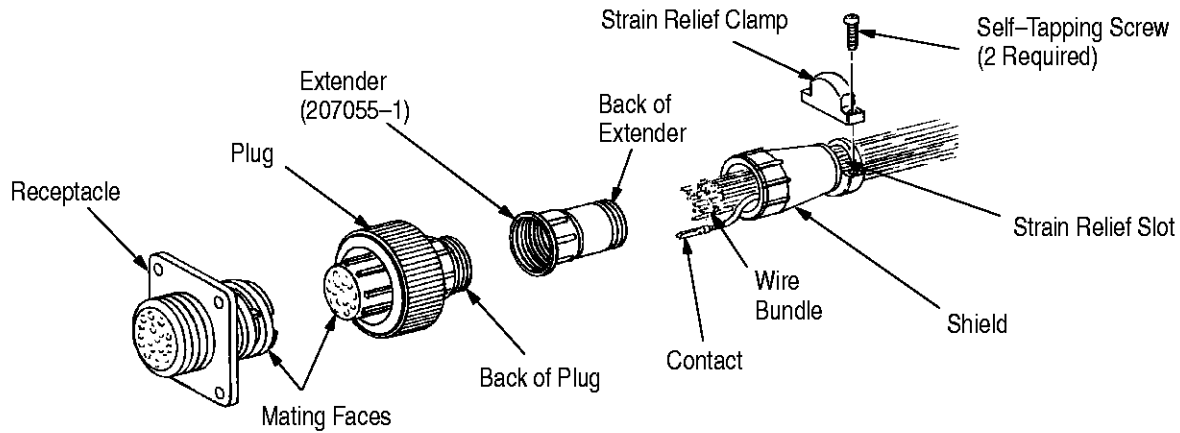

Connector Size	Shield And Strain Relief Kit		Clamp	
	Size	Part Number	Type	Qty
11	Standard	206062-1	Reversible	1
	Standard	206062-3	Reversible	1
	Large	206358-1	Reversible	2
13	Standard	206966-1	Reversible	2
	Large	207008-1	Reversible	2
17	Standard	206070-1	Reversible	2
	Large	206322-1	Reversible	2
23	Standard	206138-1	Reversible	2
	Large	206512-1	Nonreversible	4
	Large	207774-1	Reversible	2

Figure 1

## 1. INTRODUCTION

This instruction sheet covers the installation of AMP\* CPC shield and strain relief kits, extenders, flexible strain relief boots and grippers, jacketed cable sealing kits, sealing boots, peripheral seals, heat shrink sealing boots, sealing caps, keying plugs, coupling rings, and plug flanges.

Accessories are selected according to the connector size. The connector size is determined by measuring the distance across the coupling threads — plug or receptacle — and converting the dimension to 16ths of an inch. For example, Size 11 would measure 11/16ths of an inch across the coupling threads.

Read these instructions, and the material packaged with the connectors and crimp tooling, before installing any of the accessories.

### NOTE

References to contacts, tooling, and instructional material are included in AMP Instruction Sheet 408-7593, packaged with the connector.

### NOTE

Dimensions are in metric units [with U.S. customary units in brackets], unless otherwise specified.

Reasons for reissue can be found in Section 14, REVISION SUMMARY.

## 2. DESCRIPTION

Shield and strain relief kits include a shield, strain relief clamps, and two self-tapping screws. These kits can be attached to the plug and/or receptacle of free-hanging or panel-mounted connectors.

Extenders are used with shield and strain relief (connector Size 23 only) to put the clamping area farther away from the rear of the connector.

Flexible strain relief boots and grippers are used with jacketed cable (or firmly taped discreet wires) to provide wire protection and to prevent contact pullout when severe cable–angle applications are encountered.

Jacketed cable sealing kits include a peripheral seal, boot–type cable seal, collar extender, and special strain relief clamp. These kits are used with the large–size shield and strain relief kits Size 23 only) on the plug and/or receptacle.

Sealing boots are used to provide splashproof protection at cable jacket and rear of plug and/or receptacle. They are NOT designed to be used with a shield and strain relief kit.

Peripheral seals provide splashproof protection, serve as a buffer at the connector mating face, and can be used for high vibration applications. The seal is recommended for use with applications of other sealing accessories.

Heat shrink sealing boots are used to provide a splashproof strain relief for jacketed cable. The sealing boot contains an inner plastic shell that threads onto the rear of a plug or receptacle and an outer tubing (with sealant) that shrinks around the cable jacket when heat is applied.

Sealing caps are installed on the receptacle mating face to protect the receptacle from moisture and dirt contamination when the plug is removed.

Keying plugs provide additional polarization for the connectors. The plugs are recommended for socket cavities only.

Plug flanges are used in applications that require the plug half of a connector to be panel–mounted.

The coupling ring, an integral part of the plug housing, is used to lock the connectors together. If the coupling ring should ever be damaged, it can be replaced. A special four–lobe coupling ring is available (for plugs only, Size 23) for use in applications where space is not critical, and when a more positive grip on the coupling is desired.

### 3. INSTALLING SHIELD AND STRAIN RELIEF KITS

Refer to the table in Figure 1 and select the appropriate shield and strain relief kit (standard or

large) according to the connector size and the cable (wire bundle) diameter.

#### NOTE

*If the extender is to be used (connector Size 23 only), refer to Section 4, INSTALLING EXTENDER, and read that material before continuing with the following procedures.*

*If sealing kit is to be used, refer to Section 6, INSTALLING JACKETED CABLE SEALING KITS, and install shield and strain relief kit according to those procedures.*

For shield and strain relief installation (without sealing kit), proceed as follows:

1. Crimp contacts to wires according to instructional material packaged with crimp tooling.
2. Insert crimped contacts through BACK of shield. Then, insert contacts into housing according to instructions (408–7593) packaged with connector.
3. Slide shield forward and thread onto connector until it bottoms. DO NOT overtighten.

#### NOTE

*Mating the connectors before threading shield onto plug will prevent rotation of plug insert.*

4. Select an appropriate size of strain relief clamp (eg, large clamp for small bundle) from the carrier strip that holds the clamps.

#### NOTE

*Clamping area is adjustable by inverting or changing the strain relief clamps. The quantity and type of clamps supplied with the kit are listed in Figure 1.*

Insert clamp into strain relief slot until it bottoms. Clamp should bottom on wire bundle and NOT on shoulder of shield. Secure clamp with two self–tapping screws.

5. Make sure the wire bundle is properly secured. If clamp has bottomed on shoulder, or if clamp has NOT entered slot far enough, remove it and select another clamp (See Figure 2). After proper clamp has been installed, discard remaining clamp(s).

#### NOTE

*Strain Relief Kit 207774–1 for Size 23 comes with two clamps which can be configured as shown in Figure 3. The clamps are self–centering.*

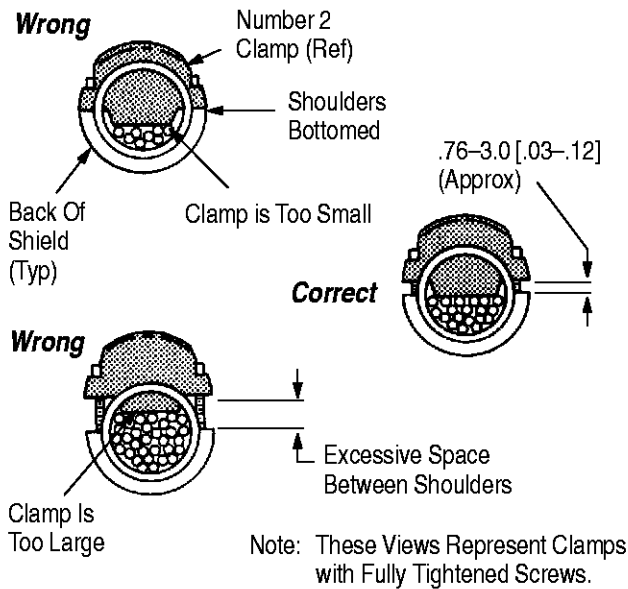

Figure 2

**4. INSTALLING EXTENDER** (Figure 1)

AMP Extender 207055-1 is used in conjunction with the shield relief on connector Size 23 only.

After crimped contacts are passed through shield, they are inserted through the BACK of the extender (external threaded end) and then into the housing. The extender threads onto the BACK of the housing and the shield threads onto the BACK of the extender. This moves the strain relief area farther back on the cable so that pulling on the contacts is avoided. The use of more than one extender is not recommended.

**5. INSTALLING FLEXIBLE STRAIN RELIEF BOOTS AND GRIPPERS** (Figure 4)

Refer to Figure 4 and select the appropriate boot and gripper according to the connector size and the cable jacket diameter.

Proceed as follows:

1. Install boot and gripper on cable before removing cable jacket. Slide boot onto cable — flexible end first. Slide gripper onto cable — slotted end first.
2. Crimp contacts to wires according to instructional material packaged with crimp tooling.
3. Insert contacts into housing according to instructions (408-7593) packaged with connector.

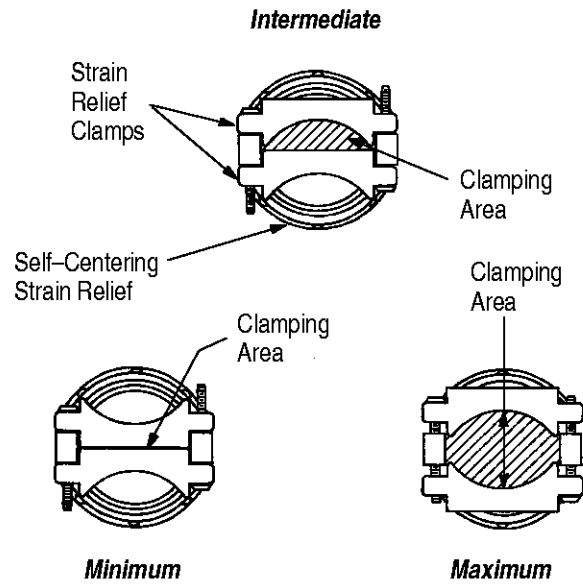

Figure 3

4. Thread gripper onto connector. Thread boot onto gripper until wire is tight. Do NOT overtighten.

**CAUTION**

Overtightening of gripper on flexible boot can fracture boot.

**NOTE**

Some threads on gripper may be exposed on larger diameter wire.

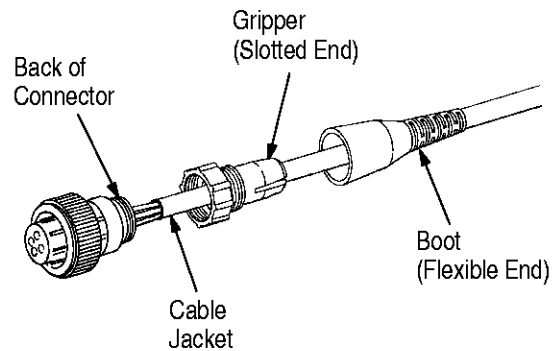

Connector Size	Cable Jacket Outside Dia	Gripper Part No.	Boot Part No.
11	6.35 Max [.250 Max]	207490-1	207489-1
17	5.08-6.35 [.200-.250]	207387-2	207241-1
	6.35-8.89 [.250-.350]	207387-2	

Figure 4

**NOTE** *Mating the connectors before threading gripper and boot onto plug will prevent rotation of plug insert.*

**6. INSTALLING JACKETED CABLE SEALING KITS**

The jacketed cable sealing kit is used with the large, Size 23 shield and strain relief kit only. Refer to Figure 5 and select the appropriate jacketed cable sealing kit according to the cable size and the cable jacket diameter.

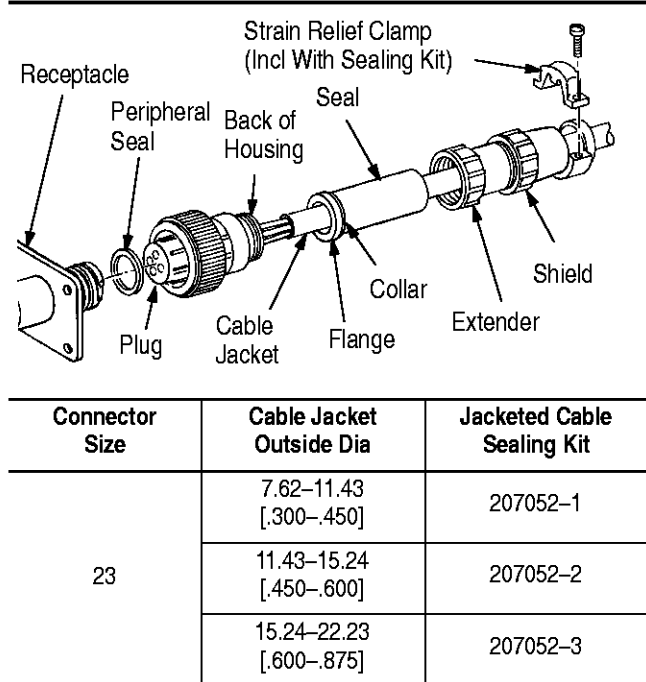

Figure 5

Install sealing kit — with shield and strain relief kit — as follows:

1. Install following items before removing cable jacket. Thread shield onto extender and slide unit onto cable, shield portion first. Assemble collar on seal, just behind flange. Slide seal onto cable with flange toward cable end.
2. Crimp contacts to wires according to instructional material packaged with crimp tooling.
3. Insert contacts into housing according to instructions (408-7593) packaged with connector.
4. Position seal (flange portion) against BACK of housing. Slide extender/shield over seal and thread unit onto housing until it is finger tight. Then tighten unit an additional half-turn.

**NOTE** *Mating the connectors before threading adapter/shield unit onto plug will prevent rotation of plug insert.*

5. Insert strain relief clamp — the one included with the sealing kit — into strain relief slot until it bottoms on cable. Secure clamp with two self-tapping screws. Discard clamps included with strain relief kit.

6. Insert peripheral seal into receptacle mating face until seal bottoms.

**7. INSTALLING SEALING BOOTS**

A sealing boot is used on jacketed cable only. Refer to Figure 6 and select the appropriate sealing boot according to the connector size.

**NOTE** *Do NOT use sealing boot when using shield and strain relief kit.*

Proceed as follows:

1. Slide sealing boot onto cable before removing cable jacket. Make sure boot collar is toward cable end.
2. Strip jacket (outer insulation) to approximately two-thirds the length of the sealing boot — a sufficient length of outer insulation must remain on the cable to ensure sealing when boot is installed.
3. Crimp contacts to wires according to instructional material packaged with crimp tooling.
4. Insert crimped contacts into housing according to 408-7593, packaged with connector.

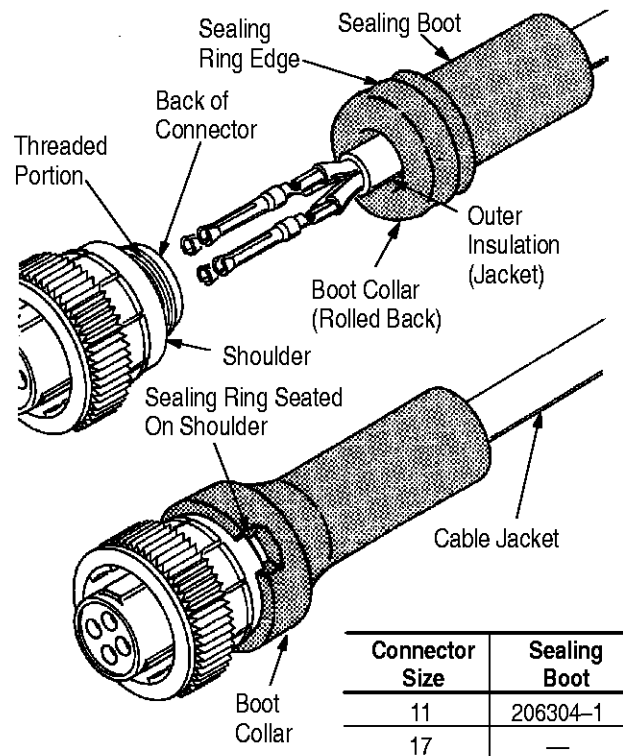

Figure 6

5. Roll boot collar back over itself — turning collar inside out, and slide boot over cable until it butts against BACK of connector.
6. Roll collar forward and onto threaded portion of connector. Seat sealing ring edge on shoulder of connector.
7. A peripheral seal is recommended for splashproof protection at the connector mating face. Refer to Section 8, SELECTING AND INSTALLING PERIPHERAL SEAL.

**8. SELECTING AND INSTALLING PERIPHERAL SEAL**

The peripheral seal is recommended for sealing for boot and heat shrink sealing boot applications. The seal also serves as a buffer between mated connectors (sealed and unsealed applications).

Proceed as follows:

1. Refer to Figure 7 and select the appropriate peripheral seal according to the connector size.
2. Apply a bonding material, such as Loctite† Super Bonder† 416, to seal to avoid loss of the seal during unmating; then insert seal into receptacle mating face until seal bottoms.

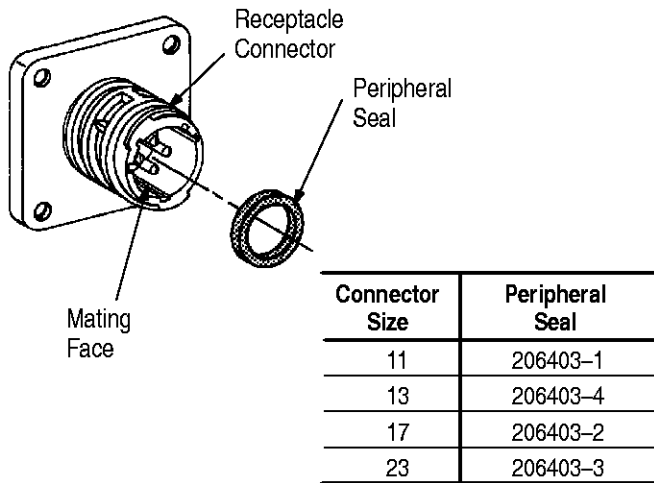

Figure 7

**9. INSTALLING HEAT SHRINK SEALING BOOTS**

Refer to Figure 8 the and select the appropriate heat shrink sealing boot according to the connector size.

Proceed as follows:

1. Before removing cable jacket, slide heat shrink sealing boot onto cable, sealant end first.

† Trademark of Loctite Corporation

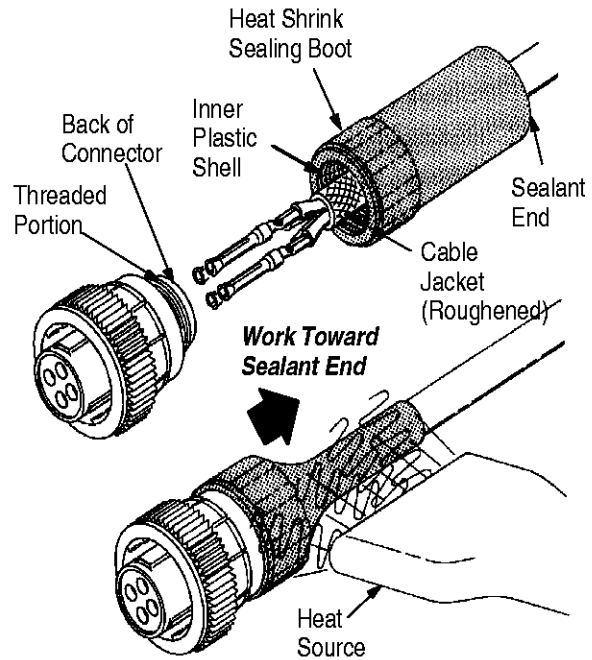

Connector Size	Heat Shrink Sealing Boot	Connector Size	Heat Shrink Sealing Boot
11	54010-1	17	54011-1
13	54123-1	23	54012-1

Figure 8

2. Crimp contacts to wires according to instructional material packaged with crimp tooling.
3. Insert contacts into housing according to instructions (408-7593) packaged with connector.

**NOTE** Cable jacket should be roughened with sandpaper in area where sealing boot will be applied.

4. Thread sealing boot onto BACK of connector.

**NOTE** Mating the connectors before threading boot onto plug will prevent rotation of plug insert.

5. Use a heat source capable of delivering at least 121° C [250° F] — electrical heat gun, propane or butane torch, oven, or heat lamp.

6. Start close to BACK of connector and work toward sealant end of boot. Apply heat evenly around circumference of boot.

**CAUTION** Keep heat source in motion to avoid over-heating and possibly damaging cable jacket and plastic parts.

7. Shrink process is complete when sealant extrudes from end of boot.

8. A peripheral seal is recommended for splashproof protection at the connector mating face. Refer to Section 8, SELECTING AND INSTALLING PERIPHERAL SEAL.

**10. INSTALLING SEALING CAPS**

Refer to Figure 9 and select the appropriate sealing cap according to the connector size and series.

The sealing cap is threaded onto the receptacle mating face until the positive lock snaps into position. The free end of the strap can be secured to one of the mounting screws under the receptacle flange.

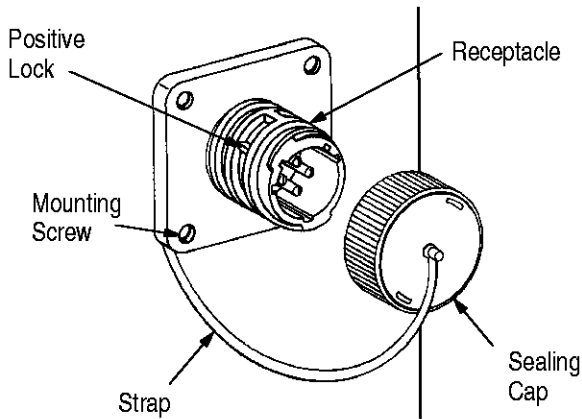

Connector		Sealing Cap	
Size	Series	Plastic Strap	Metal Chain
11	1 & 2	206903-1	208800-1
13	1	211870-1	213485-1
17	1, 2, & 3	207445-1	208652-1
23	1 & 3	207446-1	208680-1
23	2	207446-2	208680-2

Figure 9

**11. INSTALLING KEYING PLUGS**

Keying plugs vary in configuration, and the installation procedures for each connector series are different. Identify the connector series to be keyed and proceed with A, B, or C as follows:

**NOTE** All keying plugs are inserted into connectors that are recommended for socket contacts (connectors with flush mating face).

**11.1. Keying Series 1 Connectors** (Figure 10)

Select AMP Keying Plug 200821-1 and proceed as follows:

1. Locate contact cavity to be keyed on FRONT (mating face) of connector.

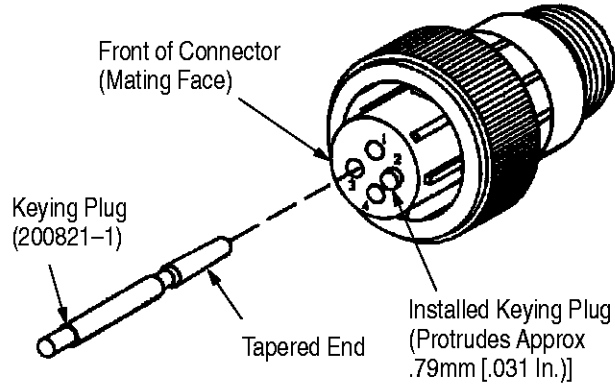

Figure 10

2. Align tapered end of plug with contact cavity. Insert plug straight into cavity until it snaps into position. When properly installed, plug should protrude from connector mating face approximately .79 [.031]

3. To remove keying plug, insert a suitable tool (3.18 [.125]-dia max drill rod) into BACK of keyed cavity and push plug out FRONT of connector.

**11.2. Keying Series 2 Connectors** (Figure 11)

Select AMP Keying Plug 206509-1 and proceed as follows:

1. Locate contact cavity to be keyed on FRONT (mating face) of connector.
2. Align pointed end of plug with contact cavity. Insert plug straight into cavity until head of plug bottoms on connector mating face.
3. To remove keying plug, insert a flat-bladed tool under head of plug and pry outward.

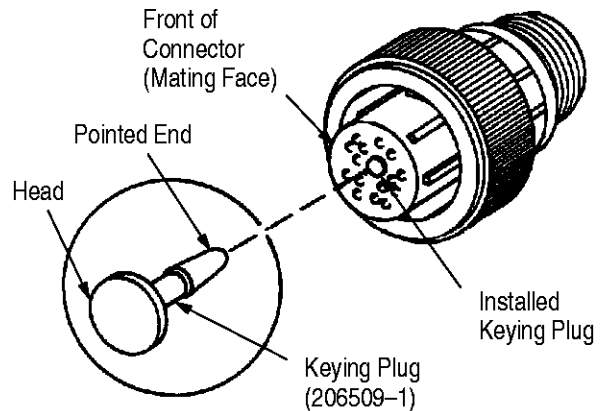

Figure 11

### 11.3. Keying Series 3 Connectors (Figure 12)

1. Locate contact cavity to be keyed on BACK (wire side) of connector.
2. Align cross-tip end of plug with contact cavity. Align locking lances with wider portion of cavity. Insert plug straight into cavity until it bottoms. Pull back lightly to be sure plug is locked in place.

#### NOTE

*It is possible to install plug in wrong direction. This will NOT damage connector or keying plug. However, plug will NOT lock in position ... and will pull back out easily.*

3. When properly installed, front of plug should be flush with connector mating face, and back of plug should protrude out BACK of connector approximately 3.2 [.125].

4. To remove keying plug, depress locking lances (through FRONT of connector) and push plug out BACK of cavity.

#### NOTE

*AMP Extraction Tool 91019-3 can be used to extract these keying plugs. Instructions 408-7276 for extraction tool use are packaged with the tool.*

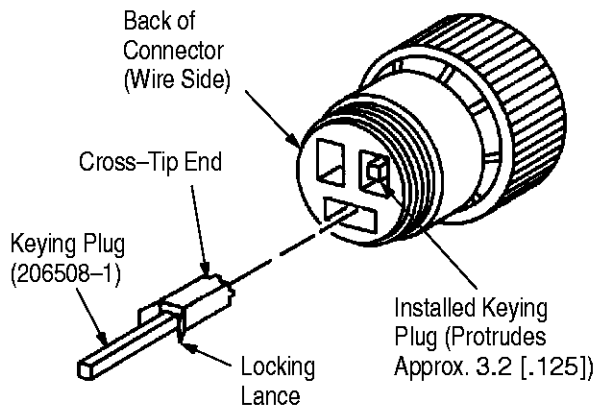

Figure 12

### 11.4. Keying Series 4 Connectors (Figures 12 and 10)

Follow procedures for Type XII Contacts (Paragraph 11.4) and Multimate Contacts (Paragraph 11.1.)

## 12. REPLACING COUPLING RING

The coupling ring is an integral part of the plug housing. In the event that it becomes damaged, or if the special coupling ring is to be installed (plug only Size 23), it can be replaced in the following manner.

#### NOTE

*It is NOT necessary to extract contacts from the plug when replacing the coupling ring.*

### 12.1. Removing Coupling Ring (Figure 13)

The coupling ring can be removed either by cutting the ring collar or by removing 3 or 4 splines and then sliding the ring off the FRONT of the connector. The latter method is accomplished by inserting a thin-bladed screwdriver between splines and prying outward.

#### CAUTION

*Use care not to damage connector threads and keys.*

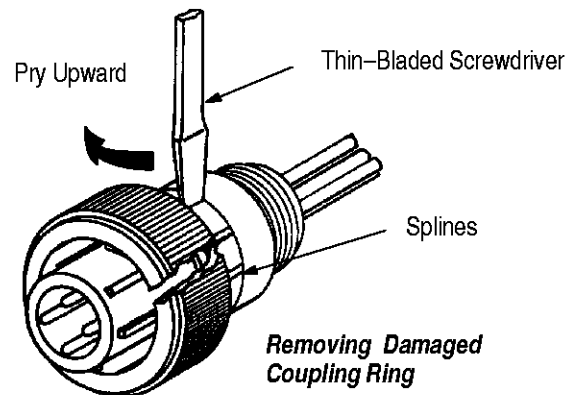

Figure 13

### 12.2. Installing Coupling Ring (Figure 14)

A coupling ring is installed by applying even force to the outer perimeter of both the connector and the coupling ring. A small wheel puller with a recessed or open spindle is ideal for this application.

#### NOTE

*A properly installed coupling ring will recede approximately 3.2 [.125] beyond the mating face of the connector. Therefore, it is necessary for the spindle to be recessed or open.*

Refer to Figure 14 and select the appropriate coupling ring according to the connector size.

Proceed as follows:

1. Orient coupling ring so splines are facing connector. Slide ring over FRONT of connector as far as it will go without using force.
2. Position tool grippers on BACK (wire side) of connector, being careful NOT to damage wires or threads. Position spindle on coupling ring.
3. Take up on spindle until components are snug, and check alignment of connector to spindle. Clearance must be available for connector mating face to enter spindle.
4. Tighten spindle until coupling ring splines spread and enter spline groove in connector. Remove tool and check that coupling ring is secure and that it rotates freely.

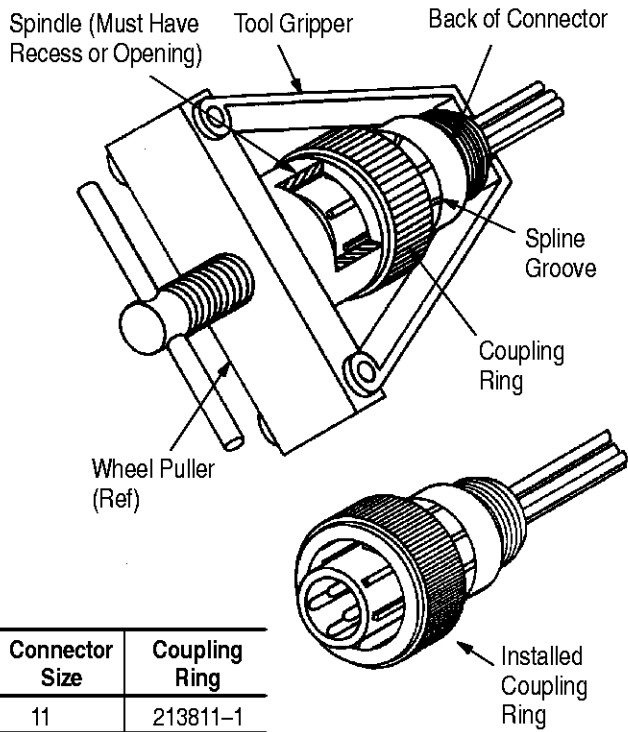

Connector Size	Coupling Ring
11	213811-1
13	213813-1
17	213810-1
23	213812-1
23	207659-1●

**Installing Coupling Ring**

● Special Four-Lobe Ring for Extra Grip

*Figure 14*

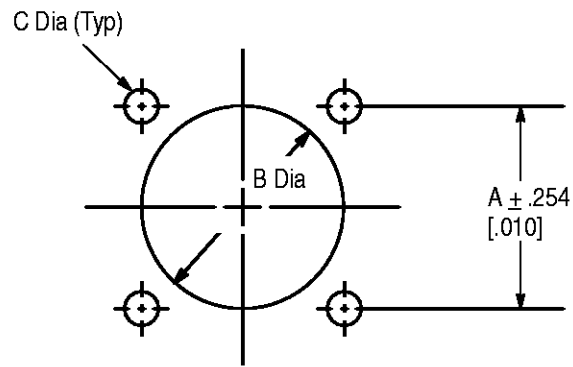
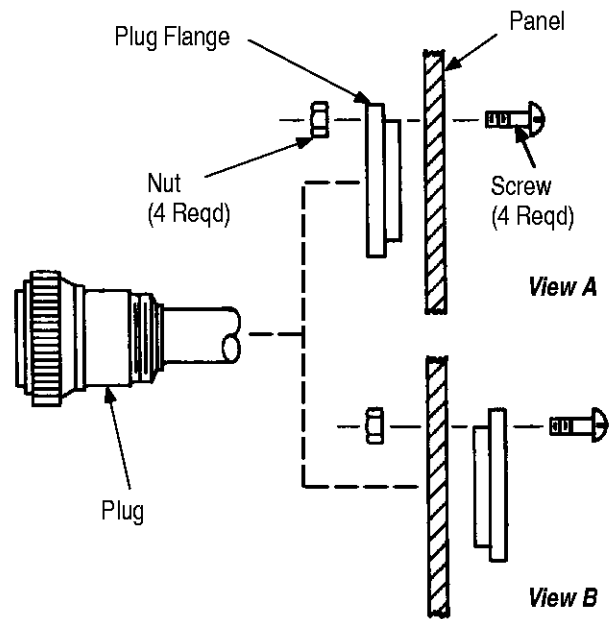

**Panel Cutout**  
3.05 [.12] Panel Thickness

**13. INSTALLING PLUG FLANGES** (Figure 15)

Refer to Figure 15 and select the appropriate plug flange according to the connector size.

Proceed as follows:

1. Make cutout in panel according to the dimensions provided in Figure 15.
2. Install the flange and plug as shown in either View A or B, depending on your application. Secure flange with four commercially available screws and nuts.

Connector Size	Plug Flange	Panel Cutout Dimension		
		A	B	C
11	207299-1	21.44 [.844]	21.34 [.840]	3.18 [.125]
13	207299-2	24.61 [.969]	24.87 [.979]	3.18 [.125]
17	207299-3	28.58 [1.125]	30.73 [1.210]	3.81 [.150]
23	207299-4	36.53 [1.438]	40.9 [1.610]	3.81 [.150]

*Figure 15*

**14. REVISION SUMMARY**

The following changes were made since the previous release of this sheet:

Per EC 0990-0763-99

- Updated coupling ring part numbers in Figure 14
- Deleted obsolete part numbers in Figure 1, Figure 4, and Figure 6
- Added Section 14, REVISION SUMMARY
- Updated document format