

ISSUE NO.	ENG. REF. NO.	DATE	APP. BY
6	-	07/03/17	<i>smurke</i>

STYLE 'C'

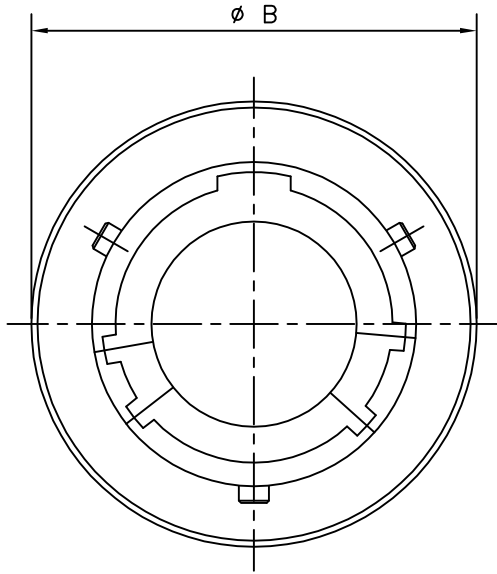

MARKING P/NO. AS PER BOM.  
(LOCATION OPTIONAL)

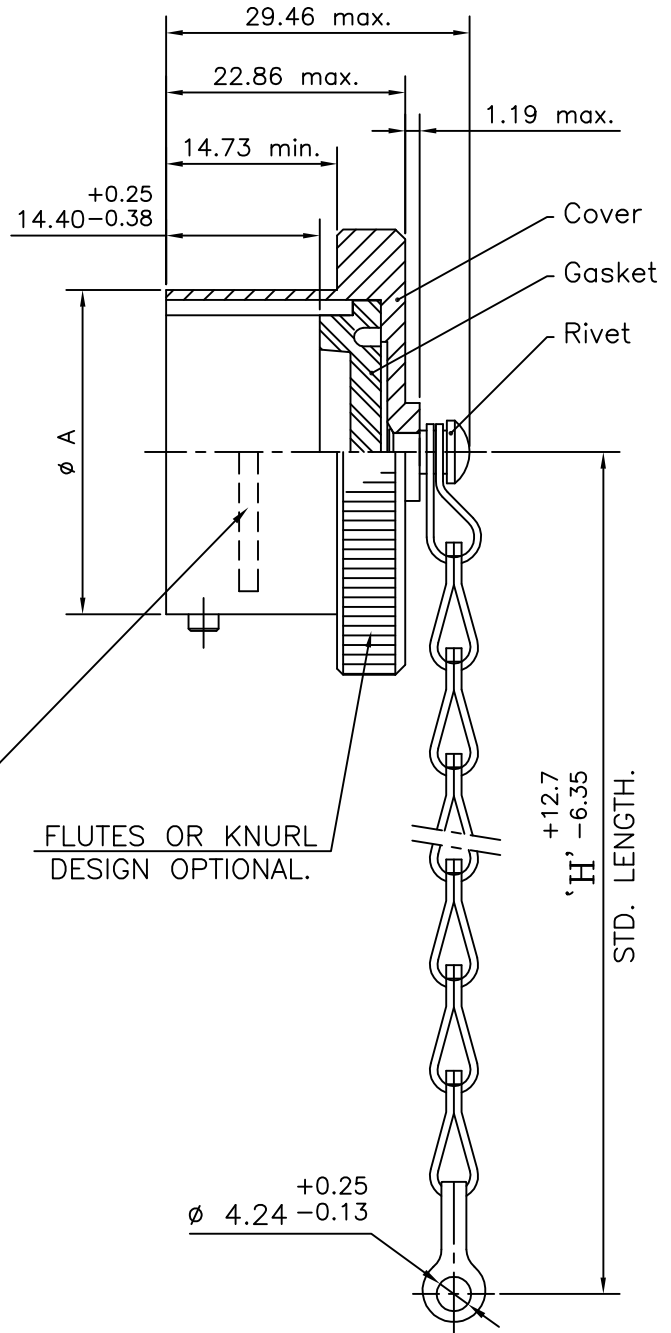

FLUTES OR KNURL  
DESIGN OPTIONAL.

CHAIN S/A.

(LJT)

QF-DEV-03 REV-NO. 02	<p><b>AMPHENOL</b> Amphenol Interconnect India Pvt. Ltd. Pune 411026</p>			<p>TITLE METAL DUST CAP ASSY. FOR D38999 SER-I PLUG CONN. (09 TO 25 SIZE)</p>		
	<p>2012</p>	<p>Name</p>	<p>Date</p>	<p>Dwg. Size</p>	<p>Dwg. No.</p>	
	<p>Drawn by</p>	<p><i>Kulkarni</i></p>	<p>05/12/12</p>	<p><b>A4</b></p>	<p><b>PSTD-10162</b></p>	<p><b>STANDARD</b></p>
	<p>Checked by</p>	<p><i>R.S.Kumar</i></p>	<p>07/12/12</p>			
	<p>App. by</p>	<p><i>smurke</i></p>	<p>10/12/12</p>	<p>Sheet 1 of 5</p>		

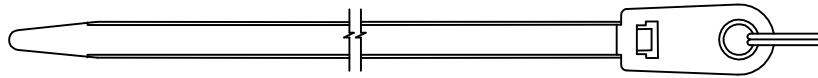

T- Tie Wrap

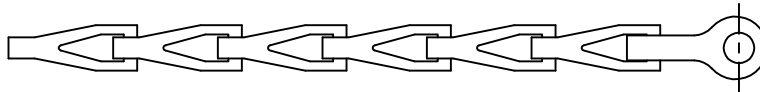

S- Sash Chain

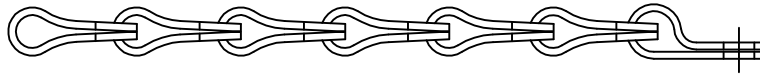

G- Nylon Cord

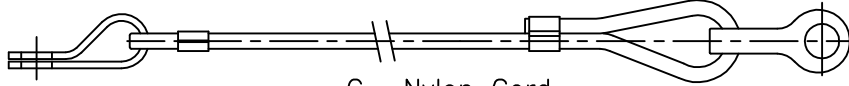

D- Bead chain

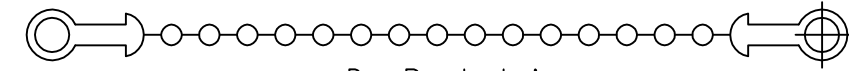

T- (SS) Wire Rope with Teflon Jacket.

All Dimensions are in MM.

SHELL SIZE	$\phi A$ +0.02 -0.13	$\phi B$ MAX.	H +12.70 -6.35
09	14.53	20.83	76.20
11	17.78	23.88	
13	21.59	27.18	88.90
15	24.77	30.23	
17	27.94	33.53	
19	30.66	36.58	
21	33.83	39.88	101.60
23	37.01	42.93	
25	40.18	46.23	

All Dimensions for reference only.

QF-DEV-03 REV-NO. 02	<b>AMPHENOL</b> Amphenol Interconnect India Pvt. Ltd. Pune 411026			TITLE METAL DUST CAP ASSY. FOR D38999 SER-I PLUG CONN. (09 TO 25 SIZE)		
	2012	Name	Date	Dwg. Size	Dwg. No.	
Drawn by	<i>Kulkarni</i>	05/12/12	A4	PSTD-10162		
Checked by	<i>P.S.Kumar</i>	07/12/12				
App. by	<i>cmurke</i>	10/12/12	Sheet 2 of 5			

**REQUIREMENTS:**

**MATERIAL :-**

Cover : Machined Aluminium alloy

Gasket : Silicone elastomer.

Ring : Stainless steel, passivated.

Rope : 7 strand stainless steel passivated with teflon coating.

Fastener : Stainless steel, passivated. Option: Aluminium Integral to cover.

**MATING CONNECTOR :- MIL-DTL-38999 series I.**

Gasket shall be mechanically retained.

Rope shall rotate freely on fastener.

(MILITARY PART NUMBER.)

ORDERING INFORMATION:

**JANMS27501 B 11 C L**

Designates Plug Dust Cover

**Class:-**

- B - Cadmium plate olive drab finish.
- C - Hard Anodize black finish.
- F - Electroless nickel finish.
- Z - Black Zinc Nickel finish.

Shell Size : 09,11,13,15,17,19,21,23 & 25

**Style:-**

- C - With Chain
- A - Without Chain

**Length**

L- 127.0 +12.7/-6.35 chain/Rope in lieu of std length.  
Leave blank for std. length. 'H'

NOTE:- FOR NON STANDARD LONG 'L' CONTACT FACTORY.

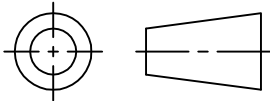
QF-DEV-03 REV-NO. 02	<b>AMPHENOL</b> Amphenol Interconnect India Pvt. Ltd. Pune 411026			TITLE METAL DUST CAP ASSY. FOR D38999 SER-I PLUG CONN. (09 TO 25 SIZE)		
	2012 Drawn by <i>Kulkarni</i> 05/12/12 Checked by <i>P.S.Kumar</i> 07/12/12 App. by <i>cmurke</i> 10/12/12	Name Date	Dwg. Size <b>A4</b>	Dwg. No. <b>PSTD-10162</b>	All Dimensions are in MM/INCHES	
					Sheet 3 of 5	<b>STANDARD</b>

(PROPRIETARY PART NUMBER.)

REQUIREMENTS:

MATERIAL :

Cover : Machined Aluminium alloy  
 Gasket : Silicone elastomer.  
 Fastener : S/Steel, passivated.

ILJT27501 - 09 - A - D - T - H

ORDERING INFORMATION:

Designates:- plug dust cover

Shell size : 09,11,13,15,17,19,21,23 & 25

Finish:

- A - Hard anodic non conductive
- W - Cadmium palte with olive drab .
- E - Electroless nickel.
- X - Zinc cobalt black.
- Z - Zink cobalt olive drab

Type of attachment:

- D - Bead chain passivated.
- G - Nylon cord.
- S - Sash chain.
- T - S.S. wire rope with teflon jacket
- X - None

Type of end link:

- T - Tie wrap
- X - None (small link hole dia 4.49 mm max)

Length of attachment:

- H - Standard length
- For non-standard 'H', length has to be specified in inches.

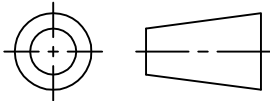
QF-DEV-03 REV-NO. 02	<b>AMPHENOL</b> Amphenol Interconnect India Pvt. Ltd. Pune 411026			TITLE METAL DUST CAP ASSY. FOR D38999 SER-I PLUG CONN. (09 TO 25 SIZE)		
	2012 Drawn by <i>Kulkarni</i> 05/12/12 Checked by <i>P.S.Kumar</i> 07/12/12 App. by <i>asmurke</i> 10/12/12	Dwg. Size <b>A4</b>	Dwg. No. <b>PSTD-10162</b>	All Dimensions are in MM/INCHES		
				Sheet 4 of 5		<b>STANDARD</b>

STYLE 'A'

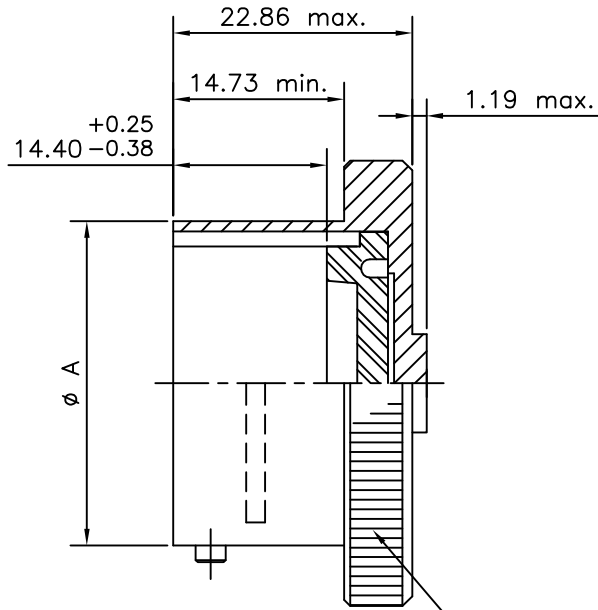

FLUTES OR KNURL  
DESIGN OPTIONAL.

REQUIREMENTS:

MATERIAL :

Cover : Machined Aluminium alloy

Gasket : Silicone elastomer.

MATING CONNECTOR: MIL-C-38999 Series I.

Gasket shall be mechanically retained.

ORDERING INFORMATION:

ILJT27501 - 08 - A - V1

Designates : Plug dust cover

Shell size : 09,11,13,15,17,19,21,23 & 25

Class

A - Hard anodic

W - Aluminium, 500 Hrs cadmium olive drab.

F - Aluminium, 48 Hrs. electroless nickel.

T - Nickel PTFE finish.

VARIANT

QF-DEV-03 REV-NO. 02	<p><b>AMPHENOL</b> Amphenol Interconnect India Pvt. Ltd. Pune 411026</p>		<p>TITLE METAL DUST CAP ASSY. FOR D38999 SER-I PLUG CONN. (09 TO 25 SIZE)</p>		
	2012	Name	Date	Dwg. No.	
Drawn by	<i>Kulkarni</i>	05/12/12	Dwg. Size	<p><b>PSTD-10162</b></p>	
Checked by	<i>R.S.Kumar</i>	07/12/12	<b>A4</b>		Sheet 5 of 5
App. by	<i>csmurke</i>	10/12/12			