

# **Decentralized motion control**

## **User's manual**

Version: **1.30 (February 2023)**  
Order no.: **MAACPMDDDE-ENG**

**Translation of the original documentation**

## **Publishing information**

B&R Industrial Automation GmbH

B&R Strasse 1

5142 Eggelsberg

Austria

Telephone: +43 7748 6586-0

Fax: +43 7748 6586-26

[office@br-automation.com](mailto:office@br-automation.com)

## **Disclaimer**

All information in this document is current as of its creation. The contents of this document are subject to change without notice. B&R Industrial Automation GmbH assumes unlimited liability in particular for technical or editorial errors in this document only (i) in the event of gross negligence or (ii) for culpably inflicted personal injury. Beyond that, liability is excluded to the extent permitted by law. Liability in cases in which the law stipulates mandatory unlimited liability (such as product liability) remains unaffected. Liability for indirect damage, consequential damage, business interruption, loss of profit or loss of information and data is excluded, in particular for damage that is directly or indirectly attributable to the delivery, performance and use of this material.

B&R Industrial Automation GmbH notes that the software and hardware designations and brand names of the respective companies used in this document are subject to general trademark, brand or patent protection.

Hardware and software from third-party suppliers referenced in this document is subject exclusively to the respective terms of use of these third-party providers. B&R Industrial Automation GmbH assumes no liability in this regard. Any recommendations made by B&R Industrial Automation GmbH are not contractual content, but merely non-binding information for which no liability is assumed. When using hardware and software from third-party suppliers, the relevant user documentation of these third-party suppliers must additionally be consulted and, in particular, the safety guidelines and technical specifications contained therein must be observed. The compatibility of the products from B&R Industrial Automation GmbH described in this document with hardware and software from third-party suppliers is not contractual content unless this has been separately agreed in individual cases; in this respect, warranty for such compatibility is excluded in any case, and it is the sole responsibility of the customer to verify this compatibility in advance.

<b>1 Introduction.....</b>	<b>9</b>
1.1 Manual history.....	9
<b>2 General safety guidelines.....</b>	<b>10</b>
2.1 Organization of notices.....	10
2.2 General information.....	10
2.3 Qualified personnel.....	11
2.4 Intended use.....	11
2.5 Protection against electrostatic discharge.....	11
2.5.1 Packaging.....	11
2.5.2 Regulations for proper ESD handling.....	12
2.6 Transport and storage.....	12
2.7 Handling and installation.....	12
2.8 Operation.....	13
2.8.1 Protection against touching electrical parts.....	13
2.8.2 Protection against hazardous movements.....	14
2.8.3 Protection against burns.....	14
2.9 Functional safety data and specifications.....	14
2.10 Cybersecurity disclaimer for products.....	15
<b>3 System overview.....</b>	<b>16</b>
3.1 ACOPOSremote.....	16
3.1.1 System characteristics.....	16
3.1.1.1 Decentralized and flexible.....	16
3.1.1.2 Integrated modularity.....	16
3.1.1.3 Free motor selection.....	16
3.1.1.4 Homogeneous and compatible.....	17
3.1.1.5 The ideal topology.....	17
3.1.1.6 ACOPOSmotor configurations.....	18
3.2 8CVE connection box.....	20
3.2.1 System characteristics.....	20
3.2.1.1 8CVE remote connection box.....	20
3.3 ACOPOSmotor.....	23
3.3.1 System characteristics.....	23
3.3.1.1 Compact and safe.....	23
3.3.1.2 Decentralized and flexible.....	23
3.3.1.3 Homogeneous and compatible.....	23
3.3.1.4 Cooling.....	23
3.3.1.5 ACOPOSmotor SafeMOTION.....	24
3.3.1.6 ACOPOSmotor configurations.....	24
3.4 ACOPOSmotor Compact.....	26
3.4.1 System characteristics.....	26
3.4.1.1 Compact and safe.....	26
3.4.1.2 Decentralized and flexible.....	27
3.4.1.3 Homogeneous and compatible.....	27
3.4.1.4 Cooling.....	27
3.4.1.5 ACOPOSmotor Compact configurations.....	27
<b>4 Technical data.....</b>	<b>29</b>
4.1 ACOPOSremote.....	29
4.1.1 Overview.....	29
4.1.2 Inverter modules.....	31
4.1.2.1 Status indicators.....	31
4.1.2.2 8CVI045S1HCS0.00-1.....	34
4.1.2.3 8CVI045E1HCS0.00-1.....	39
4.1.2.4 8CVI045H1HCS0.00-1.....	44
4.1.2.5 8CVI088S1HCS0.00-1.....	49

4.1.2.6 8CVI088E1HCS0.00-1.....	54
4.1.2.7 8CVI088H1HCS0.00-1.....	59
4.1.2.8 8CVI155S1HCS0.01-1.....	64
4.1.2.9 Pinouts.....	69
4.1.2.10 Setting the POWERLINK node number.....	72
4.1.3 Accessories.....	73
4.1.3.1 Cables.....	73
4.1.3.2 Screw sets.....	82
4.2 8CVE connection box.....	82
4.2.1 Overview.....	82
4.2.2 Connection boxes.....	84
4.2.2.1 8CVE28000HC00.00-1.....	84
4.2.3 Accessories.....	96
4.2.3.1 General accessories.....	96
4.2.3.2 Screw sets.....	96
4.2.3.3 Fuse sets.....	97
4.3 ACOPOSmotor.....	99
4.3.1 8DI - Order key.....	99
4.3.1.1 Size (c).....	100
4.3.1.2 Length (d).....	100
4.3.1.3 Safety technology (e).....	100
4.3.1.4 Encoder system (ff).....	101
4.3.1.5 Nominal speed (ggg).....	101
4.3.1.6 Electronics options (h).....	102
4.3.1.7 Motor options (i).....	102
4.3.1.8 Special motor options (k).....	103
4.3.1.9 Version.....	103
4.3.2 8ZDFB fan kits.....	103
4.3.3 Load capacity of the shaft end and bearings.....	104
4.3.5 ACOPOSmotor modules - Indicators.....	105
4.3.5.1 POWERLINK - LED status indicators.....	105
4.3.5.2 RDY/ERR - LED status indicators.....	105
4.3.5.3 Status changes when starting up the operating system loader.....	106
4.3.6 ACOPOSmotor SafeMOTION - Indicators.....	106
4.3.6.1 LED status indicators.....	106
4.3.6.2 RDY/ERR - LED status indicators.....	107
4.3.6.3 POWERLINK - LED status indicators.....	107
4.3.6.4 SafeMOTION module - LED status indicators.....	107
4.3.6.5 Status changes when starting up the operating system loader.....	108
4.3.7 ACOPOSmotor with electronic options - Order data.....	109
4.3.8 ACOPOSmotor without electronic options - Order data.....	110
4.3.9 Technical data.....	111
4.3.9.1 General information.....	111
4.3.9.2 Inverter module.....	112
4.3.9.3 Encoder.....	113
4.3.10 Size 3.....	114
4.3.10.1 Technical data.....	114
4.3.10.2 8DI33e.fggghi00-l - Speed-torque characteristic curve.....	115
4.3.10.3 8DI34e.fggghi00-l - Speed-torque characteristic curve.....	116
4.3.10.4 Maximum shaft load.....	116
4.3.11 Size 4.....	118
4.3.11.1 Technical data.....	118
4.3.11.2 Speed-torque characteristic curve with 560 VDC DC bus voltage.....	119
4.3.11.3 Speed-torque characteristic curve with 750 VDC DC bus voltage.....	120
4.3.11.4 Maximum shaft load.....	121
4.3.12 Size 5.....	123
4.3.12.1 Technical data.....	123

4.3.12.2 Speed-torque characteristic curve with 560 VDC DC bus voltage.....	124
4.3.12.3 Speed-torque characteristic curve with 750 VDC DC bus voltage.....	125
4.3.12.4 Maximum shaft load.....	126
4.3.13 Dimension diagrams and installation dimensions.....	127
4.3.13.1 Size 3.....	127
4.3.13.2 SafeMOTION - Size 3.....	128
4.3.13.3 Size 4.....	130
4.3.13.4 SafeMOTION - Size 4.....	132
4.3.13.5 Size 5.....	133
4.3.13.6 SafeMOTION - Size 5.....	135
4.3.13.7 Permissible mounting orientations.....	136
4.3.14 Pinouts.....	137
4.3.14.1 Overview.....	137
4.3.15 Setting the POWERLINK node number.....	139
4.4 ACOPOSmotor Compact.....	140
4.4.1 8D1 order key.....	140
4.4.1.1 Construction type (b).....	141
4.4.1.2 Size (c).....	141
4.4.1.3 Length (d).....	141
4.4.1.4 Motor encoder system / Electronics option (e).....	142
4.4.1.5 Nominal speed (f).....	142
4.4.1.6 Motor options (g).....	142
4.4.1.7 Gearbox (h).....	145
4.4.1.8 Gearbox size (i).....	146
4.4.1.9 Gear ratio (j).....	147
4.4.1.10 Gearbox options (k).....	148
4.4.1.11 Special motor options (ll).....	148
4.4.2 Load due to radial and axial force.....	149
4.4.3 Status indicators.....	150
4.4.3.1 POWERLINK - LED status indicators.....	150
4.4.3.2 RDY/ERR - LED status indicators.....	150
4.4.3.3 Status changes when starting up the operating system loader.....	151
4.4.4 Order data for ACOPOSmotor Compact modules.....	152
4.4.5 Technical data.....	153
4.4.5.1 General information.....	153
4.4.5.2 Inverter module.....	154
4.4.5.3 Power dissipation.....	155
4.4.5.4 Formula symbols.....	156
4.4.6 8D1A2 - Technical data.....	157
4.4.6.1 Technical data.....	157
4.4.6.2 8D1A22.elghijkhh-1 - Speed-Torque characteristic curve.....	157
4.4.6.3 8D1A23.eDghijkhh-1 - Speed-Torque characteristic curve.....	158
4.4.6.4 8D1A23.eHghijkhh-1 - Speed-Torque characteristic curve.....	158
4.4.6.5 Maximum shaft load.....	158
4.4.7 8D1B2 - Technical data.....	160
4.4.7.1 Overview.....	160
4.4.7.2 8D1B22.el - 4,500 rpm (8GM40, gearbox size 060) - Technical data.....	161
4.4.7.3 8D1B22.el - 4,500 rpm (8GM45, gearbox size 067) - Technical data.....	163
4.4.7.4 8D1B22.el - 4,500 rpm (8GM50, gearbox size 070) - Technical data.....	165
4.4.7.5 8D1B22.el - 4,500 rpm (8GM55, gearbox size 060) - Technical data.....	167
4.4.7.6 8D1B22.el - 4,500 rpm (8GG40, gearbox size 064) - Technical data.....	169
4.4.7.7 8D1B23.eD - 2,000 rpm (8GM40, gearbox size 060) - Technical data.....	171
4.4.7.8 8D1B23.eD - 2,000 rpm (8GM45, gearbox size 067) - Technical data.....	173
4.4.7.9 8D1B23.eD - 2,000 rpm (8GM50, gearbox size 070) - Technical data.....	175
4.4.7.10 8D1B23.eD - 2,000 rpm (8GM55, gearbox size 060) - Technical data.....	177
4.4.7.11 8D1B23.eD - 2,000 rpm (8GG40, gearbox size 064) - Technical data.....	179
4.4.7.12 8D1B23.eH - 4,100 rpm (8GM40, gearbox size 060) - Technical data.....	181

4.4.7.13 8D1B23.eH - 4,100 rpm (8GM45, gearbox size 067) - Technical data.....	183
4.4.7.14 8D1B23.eH - 4,100 rpm (8GM50, gearbox size 070) - Technical data.....	185
4.4.7.15 8D1B23.eH - 4,100 rpm (8GM55, gearbox size 060) - Technical data.....	187
4.4.7.16 8D1B23.eH - 4,100 rpm (8GG40, gearbox size 064) - Technical data.....	189
4.4.8 8D1C2 - Technical data.....	191
4.4.8.1 8GP40, gearbox size 060 - Technical data.....	193
4.4.8.2 8GP40, gearbox size 080 - Technical data.....	194
4.4.8.3 8GP45, gearbox size 067 - Technical data.....	197
4.4.8.4 8GP45, gearbox size 089 - Technical data.....	198
4.4.8.5 8GP50, gearbox size 070 - Technical data.....	201
4.4.8.6 8GP50, gearbox size 090 - Technical data.....	202
4.4.8.7 8GP55, gearbox size 060 - Technical data.....	205
4.4.8.8 8GP55, gearbox size 080 - Technical data.....	206
4.4.8.9 8GP60, gearbox size 070 - Technical data.....	209
4.4.8.10 8GP70, gearbox size 070 - Technical data.....	212
4.4.8.11 8GF40, gearbox size 064 - Technical data.....	215
4.4.8.12 8GF60, gearbox size 064 - Technical data.....	216
4.4.8.13 8GF70, gearbox size 064 - Technical data.....	219
4.4.8.14 8GA40, gearbox size 060 - Technical data.....	221
4.4.8.15 8GA40, gearbox size 080 - Technical data.....	224
4.4.8.16 8GA45, gearbox size 067 - Technical data.....	227
4.4.8.17 8GA45, gearbox size 089 - Technical data.....	230
4.4.8.18 8GA50, gearbox size 070 - Technical data.....	233
4.4.8.19 8GA50, gearbox size 090 - Technical data.....	236
4.4.8.20 8GA55, gearbox size 064 - Technical data.....	239
4.4.8.21 8GA60, gearbox size 070 - Technical data.....	242
4.4.9 Dimension diagrams and installation dimensions.....	244
4.4.9.1 Overview.....	244
4.4.9.2 8D1A2x.....	245
4.4.9.3 8D1B2x.xxxBD - 8GM40 gearbox (gearbox size 060).....	246
4.4.9.4 8D1B2x.xxxCF - 8GM45 gearbox (gearbox size 067).....	247
4.4.9.5 8D1B2x.xxxDG - 8GM50 gearbox (gearbox size 070).....	248
4.4.9.6 8D1B2x.xxxED - 8GM55 gearbox (gearbox size 060).....	249
4.4.9.7 8D1B2x.xxxHE - 8GG40 gearbox (gearbox size 064).....	250
4.4.10 Pinouts.....	251
4.4.10.1 Hybrid cable - Pinout.....	251
4.4.10.2 Electronics option - Pinout.....	252
4.4.11 POWERLINK node number setting.....	252
<b>5 Dimensioning.....</b>	<b>253</b>
5.1 ACOPOSremote.....	253
5.1.1 Power supply.....	253
5.1.2 Protective ground connection.....	253
5.1.3 Motor connection.....	255
5.1.4 Connecting ACOPOSremote 8CVI inverter modules to the ACOPOSmulti drive system.....	257
5.1.4.1 Procedure.....	257
5.1.4.2 Example.....	259
5.1.5 Connecting ACOPOSremote 8CVI inverter modules to the ACOPOS P3 drive system.....	263
5.1.5.1 Procedure.....	263
5.1.5.2 Example.....	264
5.2 8CVE connection box.....	267
5.2.1 Power supply.....	267
5.2.2 Protective ground connection.....	267
5.2.3 Procedure for connecting an ACOPOSremote inverter module to an existing ACOPOSmulti drive system.....	269
5.2.3.1 Procedure.....	269
5.2.3.2 Example.....	270

5.3 ACOPOSmotor.....	273
5.3.1 Power supply.....	273
5.3.2 Protective ground connection.....	273
5.3.3 Connecting ACOPOSmotor 8DI modules to an ACOPOSmulti drive system.....	274
5.3.3.1 Procedure.....	274
5.3.3.2 Example.....	275
5.3.4 Connecting ACOPOSmotor 8DI to an ACOPOS P3 drive system.....	278
5.3.4.1 Procedure.....	278
5.3.4.2 Example.....	279
5.4 ACOPOSmotor Compact.....	281
5.4.1 Power supply.....	281
5.4.1.1 Power supply unit.....	281
5.4.2 Fuse protection of the power supply cable.....	281
5.4.3 Procedure for sizing the DC bus.....	282
5.4.3.1 Dimensioning example 1.....	283
5.4.3.2 Dimensioning example 2.....	284
5.4.4 Procedure for sizing the STO power supply cable.....	285
5.4.4.1 Dimensioning example 1.....	287
5.4.4.2 Dimensioning example 2.....	288
<b>6 Installation and wiring.....</b>	<b>289</b>
6.1 ACOPOSremote.....	289
6.1.1 Installation.....	289
6.1.1.1 General information.....	289
6.1.1.2 Dimension diagrams and installation dimensions.....	290
6.2 8CVE connection box.....	291
6.2.1 Installation.....	292
6.2.1.1 General information.....	292
6.2.1.2 Dimension diagrams and installation dimensions.....	293
6.2.1.3 Configuration of the 8CVE connection box.....	294
6.2.1.4 Install the 8CVE connection box.....	298
6.2.1.5 Cabling for the 8CVE connection box.....	299
6.3 ACOPOSmotor / ACOPOSmotor Compact.....	301
6.3.1 Installation and connection.....	301
6.3.1.1 Before installation.....	301
6.3.1.2 Safety.....	301
6.3.1.3 Shaft end and bearing.....	304
6.3.1.4 Installing in the system.....	306
6.3.1.5 Connecting and disconnecting the motor.....	307
6.3.1.6 Cable clamp and bend radius.....	308
<b>7 Safety technology.....</b>	<b>309</b>
7.1 ACOPOSremote / 8CVE connection box / ACOPOSmotor.....	309
7.1.1 Standard safety technology ("hardwired safety technology").....	309
7.1.1.1 General information.....	309
7.1.1.2 Principle - Implementing the safety function.....	310
7.1.1.3 Wiring the enable inputs to the required Safety Category / SIL / PL.....	312
7.1.1.4 Wiring the enable inputs to the required Safety Category / SIL / PL and functionality (STO, SS1, SS2, SLS, SOS).....	316
7.1.2 SafeMOTION - Functional safety technology.....	334
7.2 ACOPOSmotor Compact.....	335
7.2.1 Standard safety technology ("hardwired safety technology").....	335
7.2.1.1 General information.....	335
7.2.1.2 Principle - Implementing the safety function.....	337
7.2.1.3 General danger notices.....	338
7.2.1.4 Wiring the enable inputs to the required safety category / SIL / PL.....	340
7.2.1.5 Wiring the enable inputs per required safety category / SIL / PL and functionality (STO, SS1, SS2,	

SLS, SOS).....	343
<b>8 Accessories.....</b>	<b>356</b>
8.1 ACOPOSremote / 8CVE connection box / ACOPOSmotor.....	356
8.1.1 General accessories.....	356
8.1.1.1 Overview.....	356
8.1.1.2 Cables.....	357
8.1.1.3 Fan kits.....	374
8.1.1.4 Blind covers / caps.....	377
8.2 ACOPOSmotor Compact.....	379
8.2.1 Accessories for ACOPOSmotor Compact.....	379
8.2.1.1 Cables.....	379
<b>9 Standards and certifications.....</b>	<b>386</b>
9.1 International and national certifications.....	386
9.1.1 Marks.....	386
9.1.2 EU directives and standards (CE).....	387
9.1.2.1 Requirements for immunity to disturbances.....	389
9.1.2.2 Emission requirements.....	390
9.1.2.3 Mechanical conditions.....	391
9.1.2.4 Climate conditions.....	391
9.1.2.5 Electrical safety.....	392
9.1.3 UL / CSA - ACOPOSremote / ACOPOSmotor (8DI).....	392
9.1.4 UL / CSA - ACOPOSmotor Compact (8D1).....	393
9.1.5 KC.....	393
9.1.6 UKCA.....	393
9.1.6.1 Supply of machinery (safety) regulations.....	394
9.2 Standards and definitions for safety technology.....	395
<b>10 Disposal.....</b>	<b>397</b>
10.1 Safety.....	397
10.1.1 Protective equipment.....	397
10.1.2 Rotor with rare earth magnets.....	397
<b>Appendix A ACOPOSmotor 8DI modules - Derating specifications.....</b>	<b>398</b>
A.1 Continuous torque depending on ambient temperature $T_u$ .....	398
A.1.1 ACOPOSmotor modules.....	398
<b>Appendix B Accessories included in content of delivery.....</b>	<b>404</b>
B.1 Decentralized motion control.....	404
B.1.1 8CVE28000HC00.00-1, 8CVIxxxx1HCS0.00-1 and 8DIxxx.xx0xxxx00-1.....	404
<b>Appendix C UL Markings.....</b>	<b>405</b>
C.1 ACOPOSremote.....	405
C.2 ACOPOSmotor.....	405
C.3 ACOPOSmotor Compact.....	405

# 1 Introduction

## 1.1 Manual history

### Information:

**B&R makes every effort to keep user's manuals as current as possible.**

**From a safety point of view, however, the current version must be downloaded from the B&R website ([www.br-automation.com](http://www.br-automation.com)).**

Version	Date	Comment
1.30	2023-02-06	Changes / New features <ul style="list-style-type: none"> <li>Updated ACOPOSmotor Compact gearboxes (8D1B / 8D1C).</li> <li>Chapter "ACOPOSmotor Compact (8D1)"               <ul style="list-style-type: none"> <li>"Power supply" on page 281</li> <li>"Power supply unit" on page 281</li> <li>"Fuse protection of the power supply cable" on page 281</li> </ul> </li> <li>Chapter "Standards and certifications"               <ul style="list-style-type: none"> <li>"UKCA" on page 393</li> <li>"Supply of machinery (safety) regulations" on page 394</li> </ul> </li> </ul>
1.20	2022-02-16	Changes / New features <ul style="list-style-type: none"> <li>Restructured entire manual.</li> <li>Added ACOPOSmotor Compact (8D1).</li> </ul>
1.10	2021-07-07	Changes / New features <ul style="list-style-type: none"> <li>Chapter "General information"               <ul style="list-style-type: none"> <li>Updated cybersecurity disclaimer for products.</li> </ul> </li> <li>Chapter "ACOPOSremote"               <ul style="list-style-type: none"> <li>Added 8CVI155S1HCS0.01-1.</li> </ul> </li> <li>Chapter "ACOPOSmotor"               <ul style="list-style-type: none"> <li>Added "ACOPOSmotor SafeMOTION".</li> <li>Updated "Connecting an ACOPOSmotor 8DI to an ACOPOS P3 drive system"</li> </ul> </li> <li>Chapter "General accessories"               <ul style="list-style-type: none"> <li>Added hybrid cable 8CCHxxxx.11130-1, 8CCHxxxx.11230-1, 8CCHxxxx.11220-1</li> </ul> </li> <li>Revised chapter "Standards and certifications" completely and added "ACOPOSmotor SafeMOTION".</li> <li>Updated appendix "UL markings".</li> </ul>
0.40	2014-07-07	Changes / New features <ul style="list-style-type: none"> <li>ACOPOSremote chapter               <ul style="list-style-type: none"> <li>Added section "Connecting an ACOPOSremote 8CVI inverter module to an existing ACOPOSmulti drive system" to dimensioning chapter.</li> </ul> </li> <li>ACOPOSmotor chapter:               <ul style="list-style-type: none"> <li>Updated dimensioning.</li> <li>Added size 3.</li> </ul> </li> <li>Infrastructure components chapter:               <ul style="list-style-type: none"> <li>Updated dimensioning.</li> <li>Added input/output diagram.</li> </ul> </li> <li>Safety technology chapter:               <ul style="list-style-type: none"> <li>Revised figures.</li> <li>Safety categories table: Added values.</li> </ul> </li> <li>Added "General accessories" chapter.</li> <li>Added appendix.</li> </ul>
0.30	2013-08-01	Changes / New features <ul style="list-style-type: none"> <li>Revised chapter "Safety technology" (8DI).</li> <li>Added chapter "ACOPOSmotor".</li> </ul>
0.20	2012-07-06	Changes / New features <ul style="list-style-type: none"> <li>Revised chapter "Standards and certifications".</li> <li>Updated available accessories.</li> <li>Revised images in chapter "Safety technology".</li> </ul>
0.10	2011-08-25	Start of revision history publication

## 2 General safety guidelines

### 2.1 Organization of notices

#### Safety notices

Contain **only** information that warns of dangerous functions or situations.

Signal word	Description
<b>Danger!</b>	Failure to observe these safety guidelines and notices will result in death, severe injury or substantial damage to property.
<b>Warning!</b>	Failure to observe these safety guidelines and notices can result in death, severe injury or substantial damage to property.
<b>Caution!</b>	Failure to observe these safety guidelines and notices can result in minor injury or damage to property.
<b>Notice!</b>	Failure to observe these safety guidelines and notices can result in damage to property.

#### General notices

Contain **useful** information for users and instructions for avoiding malfunctions.

Signal word	Description
<b>Information:</b>	Useful information, application tips and instructions for avoiding malfunctions.

### 2.2 General information

B&R drive systems and servo motors have been designed, developed and manufactured for conventional use in industrial environments.

They have not been designed, developed and manufactured for use that involves fatal risks or hazards that could result in death, injury, serious physical harm or other loss without the assurance of exceptionally stringent safety precautions.

In particular, these risks include the use of these devices to monitor nuclear reactions in nuclear power plants, in flight control or flight safety systems as well as in the control of mass transportation systems, medical life support systems or weapons systems.

Servo drives, inverter modules and frequency inverters from B&R are not dual-use goods per Annex I of Council Regulation (EC) No. 428/2009 | 3A225, amended by Commission Delegated Regulation (EU) No. 2015/2420. The electrical output frequency of these modules is monitored; if the limit frequency is exceeded, the current movement is aborted and an error is reported.

Servo drives, inverter modules and frequency inverters with the dual-use option are dual-use goods per Annex I of Council Regulation (EC) No. 428/2009 | 3A225, amended by Commission Delegated Regulation (EU) No. 2015/2420.

The electrical output frequency of these modules is not monitored.

Modules with the dual-use option are subject to various export restrictions.

#### **Danger!**

**Drive systems and servo motors can have exposed parts with voltages applied (e.g. terminals) or hot surfaces. Additional hazards include moving machine parts. The removal of required covers, inappropriate use of the devices or their improper installation or operation can result in severe personal injury or damage to property.**

All tasks such as the transport, installation, commissioning and servicing of devices are only permitted to be carried out by qualified personnel. Qualified personnel are persons who are familiar with the transport, installation, assembly, commissioning and operation of the product and have the appropriate qualifications for their job. National accident prevention regulations must be observed.

The safety guidelines, information about connection conditions (nameplate and documentation) and limit values specified in the technical data must be read carefully before installation and commissioning and must be strictly observed.

## 2.3 Qualified personnel

Use of safety-related products is restricted to the following persons:

- Qualified personnel who are familiar with relevant safety concepts for automation technology as well as applicable standards and regulations
- Qualified personnel who plan, develop, install and commission safety equipment in machines and systems

Qualified personnel in the context of this manual's safety guidelines are those who, because of their training, experience and instruction combined with their knowledge of relevant standards, regulations, accident prevention guidelines and operating conditions, are qualified to carry out essential tasks and recognize and avoid potentially dangerous situations.

In this regard, sufficient language skills are also required in order to be able to properly understand this manual.

## 2.4 Intended use

Servo drives are components intended to be installed in electrical systems or machines. This intended use is prohibited until it has been determined that the machine complies with the regulations of EC directives 2006/42/EC (Machinery Directive) and 2004/108/CE (EMC Directive).

B&R drive systems are only permitted to be directly operated on grounded industrial power systems (TN, TN-C-S). When used in residential areas, commercial areas or small businesses, additional protective and filtering measures must be implemented by the user.

### **Danger!**

**Drive systems are not permitted to be operated directly on TT, IT and corner-grounded TN-S systems!**

For technical data as well as specifications for connection and ambient conditions, see the nameplate and user documentation. The connection and ambient conditions must be observed!

### **Danger!**

**Electronic devices are generally not failsafe. If the drive systems fails, the user is responsible for making sure that the motor is brought to a secure state.**

## 2.5 Protection against electrostatic discharge

Electrical assemblies that can be damaged by electrostatic discharge (ESD) must be handled accordingly.

### 2.5.1 Packaging

Electrical assemblies with housing do not require special ESD packaging but must be handled properly (see section [2.5.2 "Regulations for proper ESD handling " on page 12](#)).

Electrical assemblies without housings are protected by ESD-suitable packaging.

## 2.5.2 Regulations for proper ESD handling

### Electrical assemblies with housing

- Do not touch the connector contacts of connected cables.
- Do not touch the contact tips on circuit boards.

### Electrical assemblies without housing

The following applies in addition to "Electrical assemblies with housing":

- All persons handling electrical assemblies and devices in which electrical assemblies are installed must be grounded.
- Assemblies are only permitted to be touched on the narrow sides or front plate.
- Always place assemblies on suitable surfaces (ESD packaging, conductive foam, etc.).  
Metallic surfaces are not suitable surfaces!
- Assemblies must not be subjected to electrostatic discharges (e.g. due to charged plastics).
- A minimum distance of 10 cm from monitors or television sets must be maintained.
- Measuring instruments and devices must be grounded.
- Test probes of floating potential measuring instruments must be discharged briefly on suitable grounded surfaces before measurement.

### Individual components

- ESD protective measures for individual components are implemented throughout B&R (conductive floors, shoes, wrist straps, etc.).
- The increased ESD protective measures for individual components are not required for handling B&R products at customer locations.

## 2.6 Transport and storage

During transport and storage, devices must be protected against undue stress (mechanical stress, temperature, humidity, aggressive atmosphere).

Drive systems contain components sensitive to electrostatic charges that can be damaged by inappropriate handling. It is therefore necessary to provide the required protective measures against electrostatic discharge when installing or removing these drive systems.

## 2.7 Handling and installation

### Warning!

**B&R drive systems and servo motors can be heavy.**

**When handling and installing heavy B&R drive systems or servo motors, there is therefore the risk of personal injury or damage to property caused by shearing, impacts, cutting or crushing. If required, use suitable protective equipment (e.g. safety glasses, protective gloves, safety shoes)!**

Installation must be performed according to this documentation using suitable equipment and tools.

Devices may only be installed by qualified personnel without voltage applied. Before installation, voltage to the control cabinet must be switched off and prevented from being switched on again.

General safety guidelines and national accident prevention regulations (e.g. VBG 4) for working with high voltage systems must be observed.

Electrical installation must be carried out in accordance with relevant regulations (e.g. line cross section, fuse protection, protective ground connection, see also "[Dimensioning](#)" on page 253).

## 2.8 Operation

### 2.8.1 Protection against touching electrical parts

#### **Danger!**

To operate drive systems, it is necessary for certain parts to carry dangerous voltage levels over 60 VDC. Touching one of these components can result in a life-threatening electric shock. There is a risk of death, serious injury or damage to property.

Before turning on a drive system, it is important to ensure that the housing is properly connected to ground (PE rail). Ground connections must be established even when testing or operating the drive system for a short time!

Before turning the device on, all parts that carry voltage must be securely covered. During operation, all covers and control cabinet doors must remain closed.

#### **Danger!**

If the safety functions integrated in the drive system are used in an application, then the safety functions must be fully validated before the drive system is switched on for the first time. There is a risk of death, serious injury or damage to property.

Control and power connections can still carry voltage even if the motor is not turning. Touching these connections when the device is switched on is prohibited.

Before performing any work on drive systems, they must first be disconnected from the power mains and prevented from being switched on again.

#### **Danger!**

##### **Dangerously high voltage!**

Before starting work, disconnect the power supply and wait 5 minutes to ensure that the capacitors have discharged. Observe regulations!

This delay time of 5 minutes begins as soon as all of the synchronous motors connected to the drive system that has been disconnected from the power supply have come to a standstill. If the synchronous motors are not at standstill when the drive system is disconnected from the power supply, then the delay time must be extended accordingly.

ACOPOSremote and ACOPOSmotor modules are labeled with the following warning:

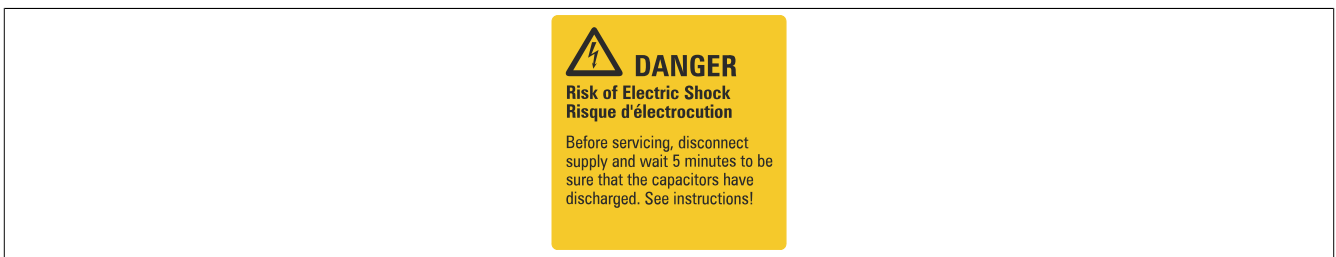

Figure 1: Warning sticker on ACOPOSremote and ACOPOSmotor modules

The connections on the drive system for signal voltages in the voltage range 5 to 30 V are safely isolated circuits. The signal voltage connections and interfaces are therefore only permitted to be connected to devices or electrical components that have sufficient isolation in accordance with IEC 60364-4-41 or EN 61800-5-1 and that correspond to SELV / PELV or a protective extra-low voltage of class DVC A per EN 61800-5-1.

Never remove the electrical connections from the drive system with voltage applied. In some cases, electric arcs may occur that can cause personal injury and/or damage to contacts.

## 2.8.2 Protection against hazardous movements

### Danger!

**Improper control of motors can result in unintended hazardous movements! Such incorrect behavior can have various causes:**

- **Incorrect installation or faults when handling components**
- **Improper or incomplete wiring**
- **Defective devices (drive system, motor, position encoder, cables, brake)**
- **Incorrect control (e.g. caused by software error)**

Several of these fault causes are detected and prevented by the drive system's internal monitoring. Nevertheless, it is still possible for the motor shaft to move any time after the device is switched on! For this reason, higher-level protective measures must be put in place to ensure that personnel and the machine are protected.

The moving parts on machines must be shielded in such a way as to prevent unintentional access by personnel. This type of protection can be achieved by using stable mechanical protective equipment such as protective covers, protective fences, protective gates or photoelectric sensors.

It is prohibited to remove, bypass or circumvent this safety equipment or to remain within the machine's range of movement.

A sufficient number of emergency switch-offs must be installed in the immediate vicinity of the machine and easily accessible at all times. This emergency switch-off equipment must be checked before the machine is commissioned.

On free running motors, the shaft key (if present) must be removed or measures taken to prevent its ejection. The holding brake built into motors cannot prevent hoisting equipment from dropping the suspended load.

## 2.8.3 Protection against burns

The surfaces of servo drives and servo motors can reach very high temperatures during operation.

Servo drives are therefore labeled with the following warning:



Figure 2: Warning on the servo drive

### Information:

**A "hot surface" warning sticker is provided with the servo motors. It must be applied so that it can be seen at any time after the motor has been mounted.**

## 2.9 Functional safety data and specifications

Specifications for individual safety functions are listed in the section [Safety technology](#).

Specifications are calculated based on a proof test interval of maximum 20 years. Since a proof test cannot be carried out for B&R drive systems, the proof test interval is the same as the system's mission time.

In accordance with EN ISO 13849, EN 62061 and IEC 61508 standards, the safety functions described in the section [Safety technology](#) cannot be used beyond the specified mission time.

### Danger!

**The user must ensure that all B&R drive systems that fulfill a safety function are replaced by new B&R drive systems or removed from operation before their mission time expires.**

## 2.10 Cybersecurity disclaimer for products

B&R products communicate via a network interface and were developed for secure connection with internal and, if necessary, other networks such as the Internet.

### Information:

**In the following, B&R products are referred to as "product" and all types of networks (e.g. internal networks and the Internet) are referred to as "network".**

It is the sole responsibility of the customer to establish and continuously ensure a secure connection between the product and the network. In addition, appropriate security measures must be implemented and maintained to protect the product and entire network from any security breaches, unauthorized access, interference, digital intrusion, data leakage and/or theft of data or information.

B&R Industrial Automation GmbH and its subsidiaries are not liable for damages and/or losses in connection with security breaches, unauthorized access, interference, digital intrusion, data leakage and/or theft of data or information.

The aforementioned appropriate security measures include, for example:

- Segmentation of the network (e.g. separation of the IT network from the control network<sup>1)</sup>)
- Use of firewalls
- Use of authentication mechanisms
- Encryption of data
- Use of anti-malware software

Before B&R releases products or updates, they are subjected to appropriate functional testing. Independently of this, we recommend that our customers develop their own test processes in order to be able to check the effects of changes in advance. Such changes include, for example:

- Installation of product updates
- Significant system modifications such as configuration changes
- Deployment of updates or patches for third-party software (non-B&R software)
- Hardware replacement

These tests should ensure that implemented security measures remain effective and that systems in the customer's environment behave as expected.

<sup>1)</sup> The term "control network" refers to computer networks used to connect control systems. The control network can be divided into zones, and there can be several separate control networks within a company or site. The term "control systems" refers to all types of B&R products such as controllers (e.g. X20), HMI systems (e.g. Power Panel T30), process control systems (e.g. APROL) and supporting systems such as engineering workstations with Automation Studio.

## 3 System overview

### 3.1 ACOPOSremote

#### 3.1.1 System characteristics

##### 3.1.1.1 Decentralized and flexible



Figure 3: ACOPOSremote 8CVI inverter module

Drive solutions that are optimally tailored to the application are a basic requirement for competitive machines and plants. Here, the direct integration of the inverters into the actuator's environment – without the need for additional accompanying measures – represents an ideal configuration. B&R takes this into account with the decentralized ACOPOSremote drive system.

This architecture offers many different advantages when it comes to machine configuration.

##### 3.1.1.2 Integrated modularity

All modules in the ACOPOSremote product line are designed with IP65 protection, which makes it possible to mount them directly on the machine. The control cabinet then only has to contain the power supply, high-powered inverter modules and other necessary electrical switching equipment. The result is a much easier implementation of modular machine architectures. When optional machine functions are required, they can easily be connected – with the requisite dimensioning of the power supply – to the machine's main line using hybrid cables.

##### 3.1.1.3 Free motor selection

Because the inverter is separate from the motor, the user is free to select the actuator best suited to his drive solution. This type of installation is particularly well suited for the increasingly prevalent linear and torque motors. It prevents the properties of the motor from being negatively influenced, and the maximum possible dynamics remain available throughout.

#### **3.1.1.4 Homogeneous and compatible**

ACOPOSremote drive systems offer the well-known functionality of the ACOPOSmulti drive family and can therefore be integrated homogeneously into a drive solution.

Optimal machine and system configurations are based on the ACOPOSremote – the ideal enhancement for modular drive solutions that require the highest levels of performance and flexibility.

#### **3.1.1.5 The ideal topology**

One of the most substantial advantages has to do with the hybrid cabling between the inverters themselves. Simply connecting ACOPOSremote drive modules together in a line – the "daisy chain" wiring scheme – results in an uncomplicated and flexible machine architecture where energy is passed from one drive module to the next.

### 3.1.1.6 ACOPOSmotor configurations

ACOPOSmotor drive systems have access to multiple technology-specific functions whose performance, flexibility and capability have been remarkably proven in countless applications. The ACOPOSmotor functions listed below are basic functions that the user can switch between as needed within 400  $\mu$ s. In addition, manipulations such as changes in product length, registration mark control, overlying torque control, brief process adaptations and quality checks can be carried out at any time.

- Point-to-point
- Electronic gears
- Electronic compensation gears
- Cross cutter
- Electronic cams
- Flying saws
- Line shafts
- CNC

ACOPOSmotor drive systems can be used in various configurations depending on the requirements of the application. The functions listed above are available to the user in each of the topology examples shown.

Reaction speeds are not influenced by the control system being used if technology functions are processed directly on the ACOPOSmotor drive system. Additional sensors and actuators must be integrated in the control system for more complex processes. In these cases, the level of performance depends mostly on the type of network and control system being used. The topology examples shown on the following pages provide an overview of the bandwidths that are possible with B&R automation components.

#### Decentralized architecture with ACOPOSremote and ACOPOSmotor

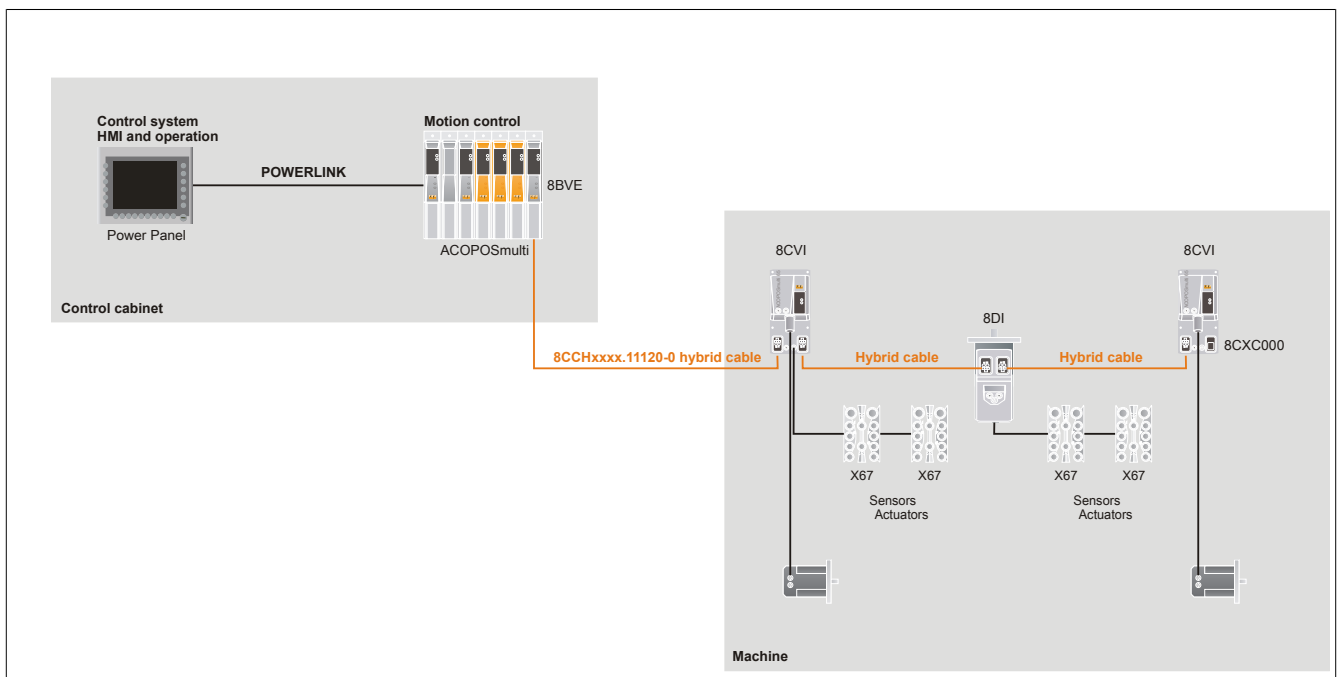

Figure 4: Decentralized architecture with ACOPOSremote and ACOPOSmotor

## Decentralized architecture with connection box 8CVE, ACOPOSremote and ACOPOSmotor

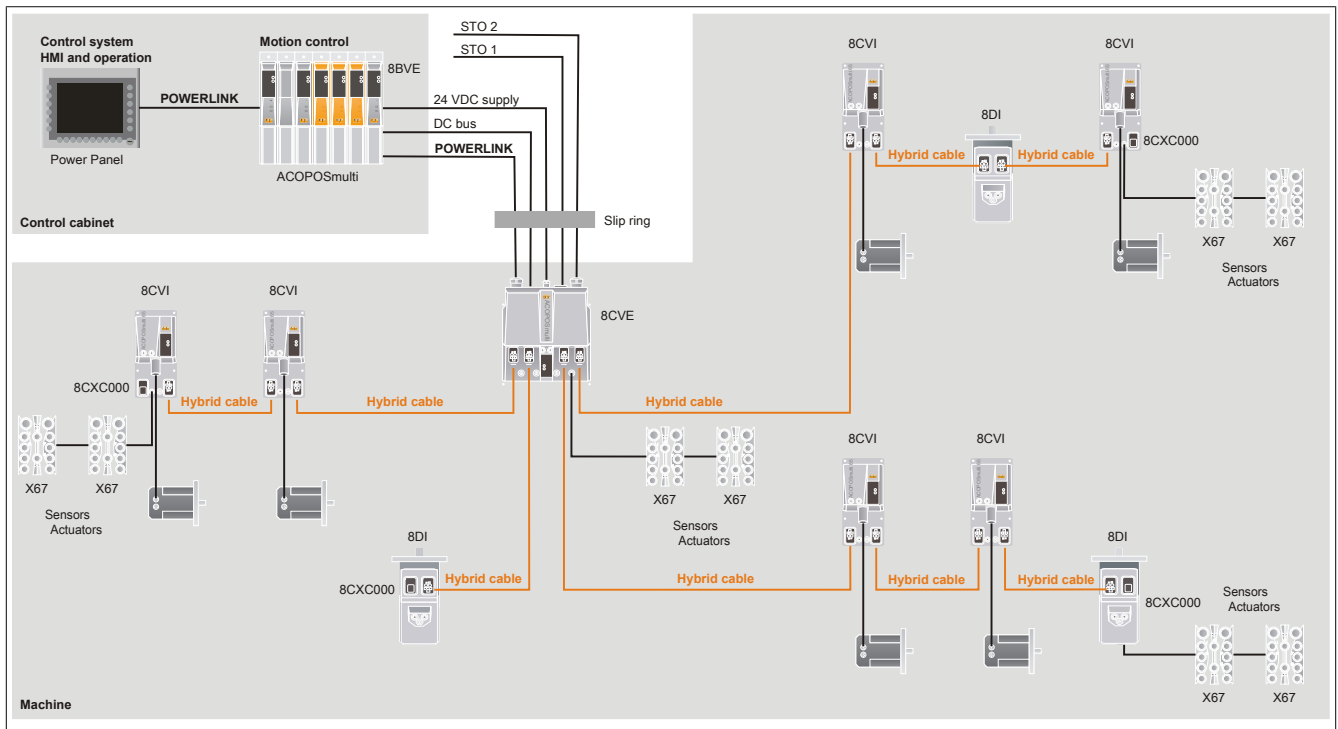

Figure 5: Decentralized architecture with connection box 8CVE, ACOPOSremote and ACOPOSmotor

## 3.2 8CVE connection box

### 3.2.1 System characteristics

#### 3.2.1.1 8CVE remote connection box



Figure 6: ACOPOSremote 8CVE connection box

An ACOPOSremote drive system is usually connected via a hybrid cable by simply arranging individual 8CVI inverter modules in a line structure. The demands placed on using a hybrid cable in this way are many. In addition to its main tasks of supplying energy and handling network communication, other aspects such as connector technology, manageability and bending radius also need to be taken into consideration. The sum of these demands results in a reasonable maximum cable diameter, but it ultimately limits the available maximum current for supplying all of the ACOPOSremote 8CVI inverters in this line structure.

In applications where this maximum current is insufficient, the necessary power must be provided in another way, made available to a remote location on-site and then redistributed from there. This is where the 8CVE remote connection box comes in.

##### 3.2.1.1.1 Robust and resistant

Like all modules in an ACOPOSremote drive system, the 8CVE remote connection box is designed with IP65 protection so it can be mounted directly on the machine. The stable housing means that it can be used even in demanding environments. This gives users flexibility when selecting installation sites in order to best suit their requirements.

##### 3.2.1.1.2 Separate cable routing means more free space

Because the power supply, the 24 V supply, the safety technology (STO signals) and the POWERLINK network are wired separately, the 8CVE remote connection box can provide a considerable amount of power directly to the machine (up to 30 kW).

Not only that, but it's also possible to use standard cables to implement alternative solutions such as transferring energy using slip rings. This provides the user with the flexibility to work with conventional connector technology while still being able to use remote servo drive technology.

### 3.2.1.1.3 Extensive connection options

The 8CVE decentralized connection box features four hybrid cable connections. In this way, performance can be divided among up to four line structures for ACOPOSremote 8CVI inverter modules and/or ACOPOSmotor 8DI modules.

Classic wiring solutions have also been taken into consideration. The necessary connections for the STO (Safe Torque Off) signals are also part of the 8CVE decentralized connection box and have a direct effect on the ACOPOSremote 8CVI inverter modules and/or ACOPOSmotor 8DI modules which are connected via hybrid cables.

In addition, the 8CVE remote connection box is equipped with two local I/O connections – another example of exemplary support for modular machine concepts.

### 3.2.1.1.4 ACOPOSremote configuration

ACOPOSremote drive systems have access to multiple technology-specific functions whose performance, flexibility and capability have been remarkably proven in countless applications. The ACOPOS functions listed below are basic functions which the user can switch between as needed within 400  $\mu$ s. Furthermore, manipulations such as changes in product length, print mark control, overlying torque control, brief process adaptations and quality checks can be carried out at any time.

- Point-to-point movements
- Electronic gears
- Electronic compensation gears
- Cutting units
- Electronic cam profiles
- Flying saws
- Line shafts
- CNC

ACOPOSremote servo drives can be used in various configurations depending on the requirements of the application. The functions listed above are available to the user in each of the topology examples shown.

Reaction speeds are not influenced by the control system being used if technology functions are processed directly on the ACOPOSremote drive system. Additional sensors and actuators must be integrated in the control system for more complex processes. In these cases, the level of performance depends mostly on the type of network and control system being used. The topology examples shown on the following pages provide an overview of the bandwidths that are possible with B&R automation components.

**Decentralized architecture with 8CVE connection box, ACOPOSremote and ACOPOSmotor**

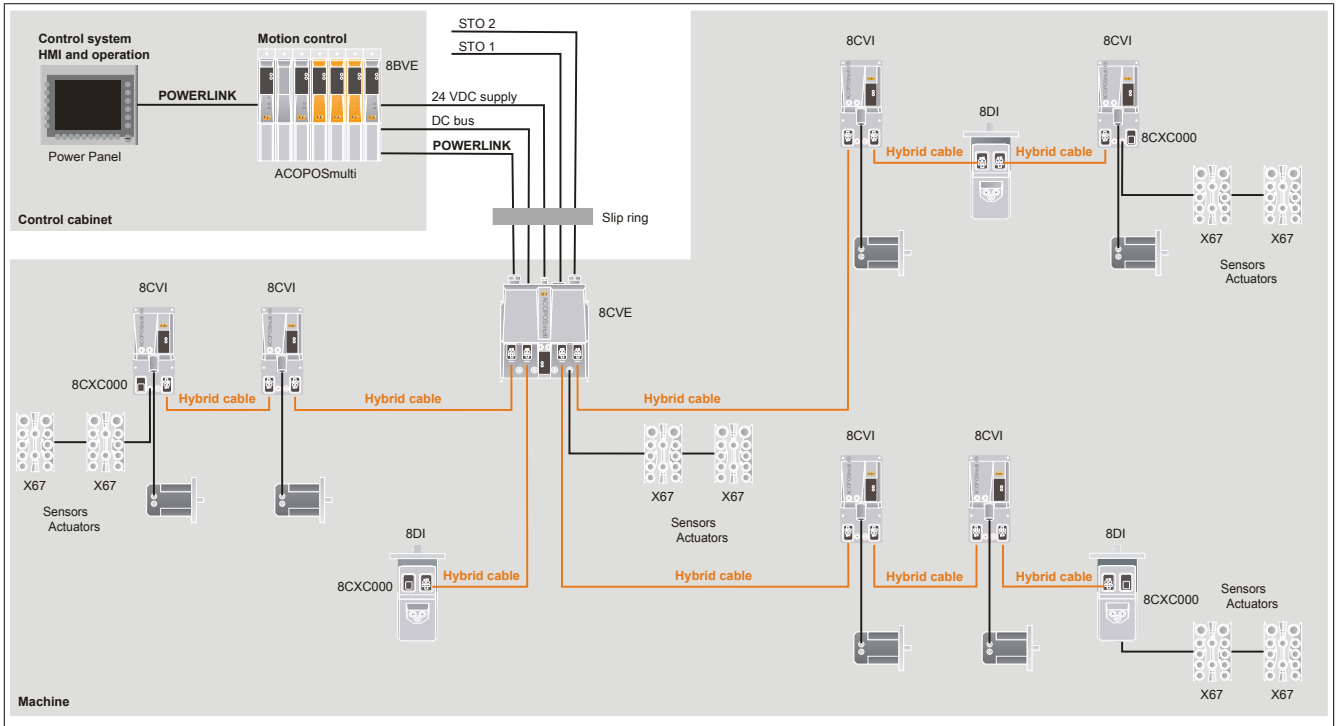
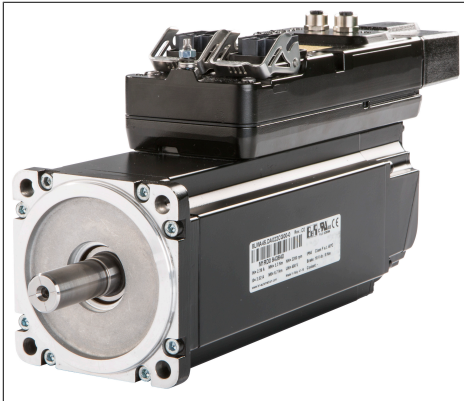

Figure 7: Decentralized architecture with 8CVE connection box, ACOPOSremote and ACOPOSmotor

## 3.3 ACOPOSmotor

### 3.3.1 System characteristics

#### 3.3.1.1 Compact and safe



ACOPOSmotor modules combine the following components in a single compact unit:

- Servo drive
- Servo motor as an energy transducer
- The built-in position sensor

ACOPOSmotor modules deliver maximum performance through the use of advanced power component technology that minimizes power loss as well as a motor series optimized for motion applications.

Available in 3 different sizes, ACOPOSmotor modules cover the entire spectrum with a torque range of 5.7 to 17 Nm and a power range of 1 kW to 2.3 kW. For applications that demand more power, an optional fan component can be added at any time to boost performance considerably.

#### 3.3.1.2 Decentralized and flexible

In terms of topology, the ACOPOSmotor module can be integrated into a simple line or tree structure. Node number assignment takes place automatically in the line structure. If the address still needs to be set, however, this can be done without opening the housing.

The connection to the drive network is made using a hybrid connector. It contains all power and signal lines needed to operate the ACOPOSmotor module as well as those required by the POWERLINK network.

Highly effective IP65 protection allows ACOPOSmotor modules to be mounted directly on the machine. The control cabinet then only has to contain the power supply, high-powered inverter modules and other necessary electro-mechanical components. This makes it much easier to implement modular machine architectures and optional machine functions since they can be easily connected – with the requisite dimensioning of the power supply – to the machine's main line using hybrid cables.

Also ideal for modular machine engineering is the ability to connect X67 modules directly to ACOPOSmotor modules, something that paves the way for implementing machine modules as completely self-sufficient and testable production units.

#### 3.3.1.3 Homogeneous and compatible

ACOPOSmotor modules provide the well-known functionality of the ACOPOSmulti drive family and can therefore be completely integrated into a drive solution.

#### 3.3.1.4 Cooling

8DI ACOPOSmotor modules are self-cooling and have a long, slim design. The modules must be installed on the cooling surface (flange).

### 3.3.1.5 ACOPOSmotor SafeMOTION

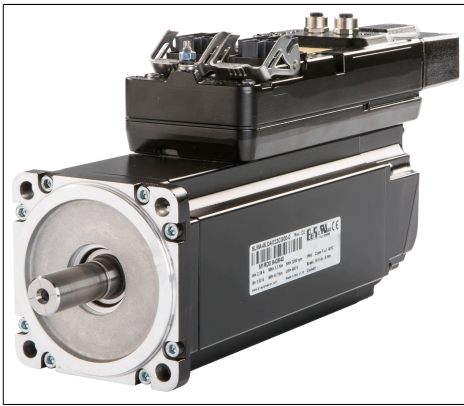

B&R's well-established safety solution – consisting of X20 SafeIO modules, SafeLOGIC controllers and the SafeDESIGNER toolset in Automation Studio – is rounded off by ACOPOSmulti SafeMOTION inverter modules and ACOPOSmotor SafeMOTION modules. All B&R "Integrated Safety Technology" products are optimized to work together, delivering elegant applications at extremely low cost levels.

#### openSAFETY sets technical standards

Although there are many new approaches to safe fieldbus systems, most of them are restricted by proprietary standards and sluggish response times. The B&R safety system – including its ACOPOSmotor SafeMOTION modules – takes a different approach by implementing openSAFETY across the board. This approach allows integrated safety functions such as Safely Limited Speed to be activated directly over the network instead of having to wire these types of safety-related signals to the drive.

Information is collected directly from its source via safe digital inputs and outputs before being distributed to the respective sensors and actuators – in this case, the drive with integrated safety functions – via a safe CPU, the SafeLOGIC controller. Connecting over a POWERLINK network makes it easy to achieve the best possible communication between the SafeLOGIC controller and the standard controller for non safety-related program engineering.

#### Short cycle times

Cycle times of 800  $\mu$ s are achieved on ACOPOSmotor SafeMOTION modules while still satisfying SIL 3 requirements.

#### Modular, expandable system

Because not all drives and axes in a production machine are safety-related, ACOPOSmotor modules are offered both with and without integrated safety functionality (SafeMOTION). This makes it possible to combine safe and non-safe axes in an application as needed.

### 3.3.1.6 ACOPOSmotor configurations

ACOPOSmotor drive systems have access to multiple technology-specific functions whose performance, flexibility and capability have been remarkably proven in countless applications. The ACOPOSmotor functions listed below are basic functions that the user can switch between as needed within 400  $\mu$ s. In addition, manipulations such as changes in product length, registration mark control, overlying torque control, brief process adaptations and quality checks can be carried out at any time.

- Point-to-point
- Electronic gears
- Electronic compensation gears
- Cross cutter
- Electronic cams
- Flying saws
- Line shafts
- CNC

ACOPOSmotor drive systems can be used in various configurations depending on the requirements of the application. The functions listed above are available to the user in each of the topology examples shown.

Reaction speeds are not influenced by the control system being used if technology functions are processed directly on the ACOPOSmotor drive system. Additional sensors and actuators must be integrated in the control system for more complex processes. In these cases, the level of performance depends mostly on the type of network and control system being used. The topology examples shown on the following pages provide an overview of the bandwidths that are possible with B&R automation components.

Decentralized architecture with ACOPOSremote and ACOPOSmotor

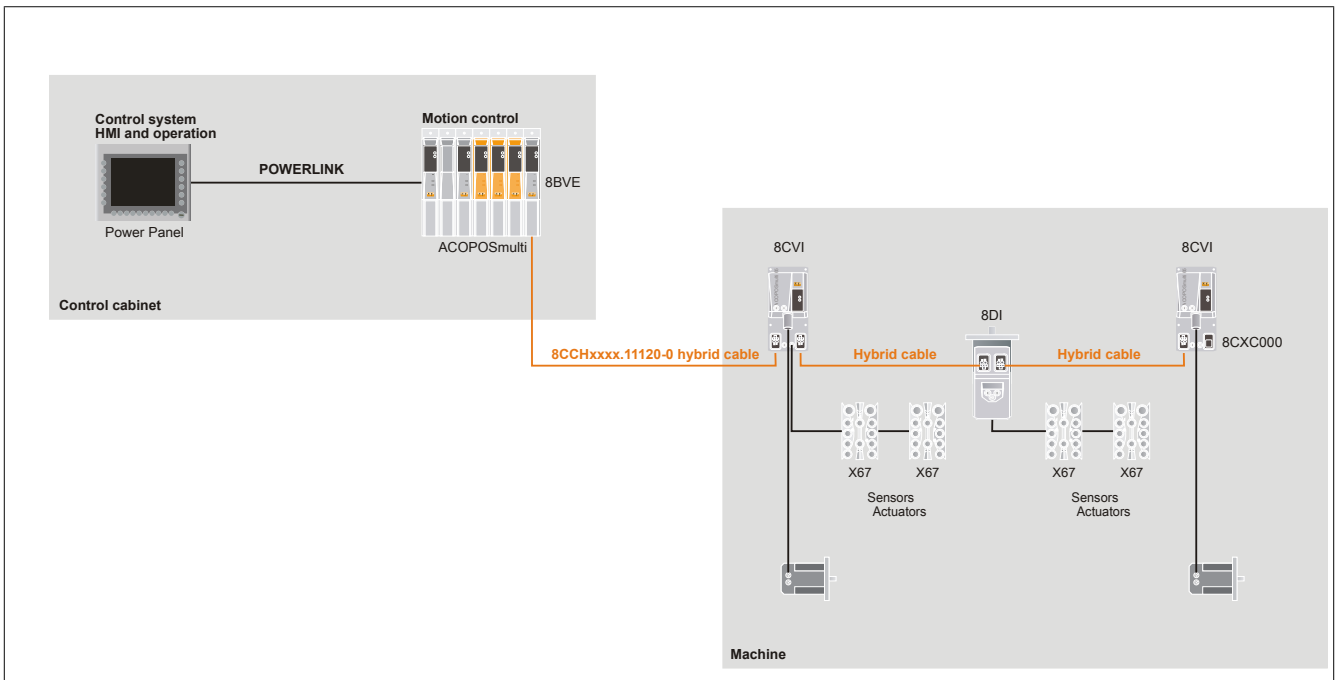

Figure 8: Decentralized architecture with ACOPOSremote and ACOPOSmotor

Decentralized architecture with connection box 8CVE, ACOPOSremote and ACOPOSmotor

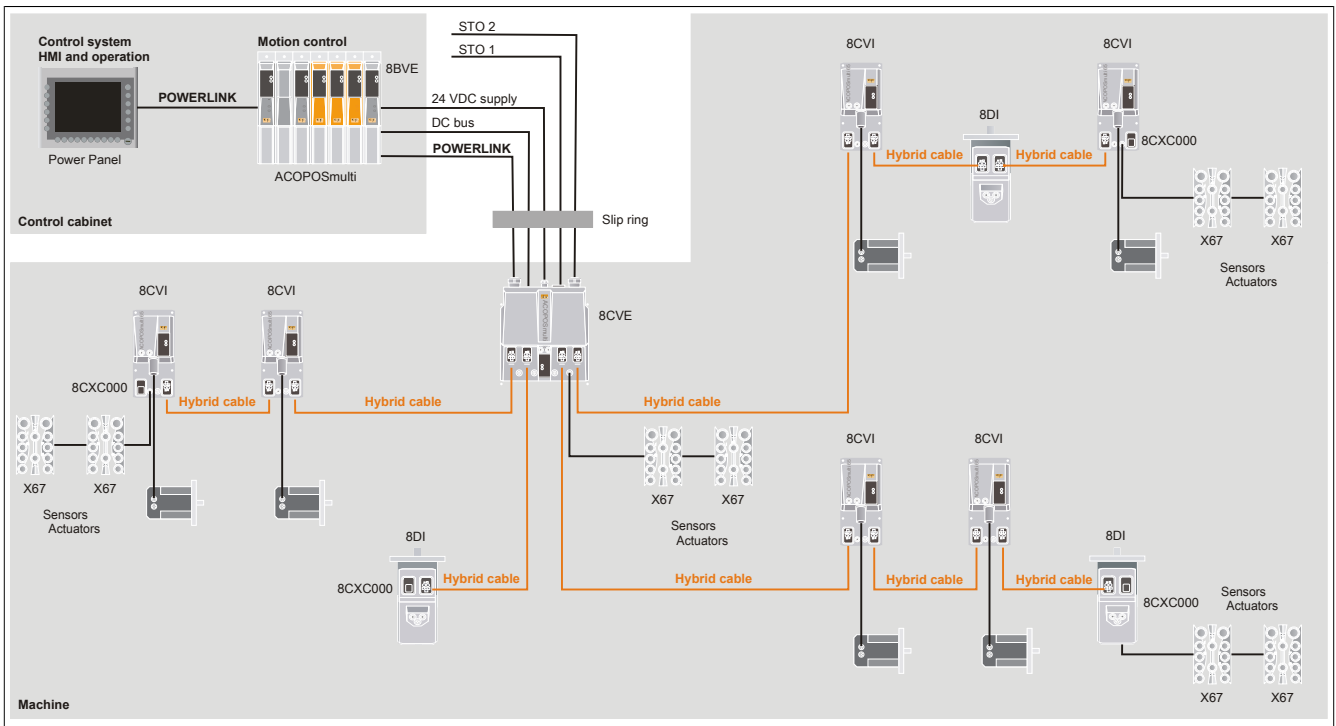

Figure 9: Decentralized architecture with connection box 8CVE, ACOPOSremote and ACOPOSmotor

## 3.4 ACOPOSmotor Compact

### 3.4.1 System characteristics

#### 3.4.1.1 Compact and safe



ACOPOSmotor Compact modules combine the following components in a single compact unit:

- Servo drive
- Servo motor as an energy transducer
- Built-in position sensor

The ACOPOSmotor Compact module achieves maximum performance through the use of the latest technology in power components with minimal power dissipation as well as from the motor series optimized for this use case.

ACOPOSmotor Compact modules cover a power range up to 0.35 kW, and the smallest variant measures just 60 mm x 90 mm (w x h). Despite their compact dimensions, they have a full-fledged integrated servo drive with control loop cycle times as fast as 50  $\mu$ s. The motors are optionally available with an integrated gearbox.

#### Daisy chaining

The devices have two connections for hybrid cables, so only a single cable is required to connect to the control cabinet. The hybrid cable transmits both the power supply and POWERLINK communication. Additional ACOPOSmotor Compact modules are easily connected via daisy chaining.

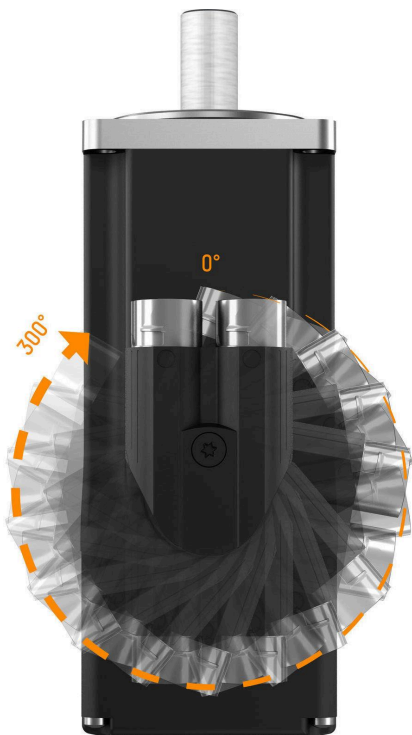

ACOPOSmotor Compact modules function over a wide voltage range from 24 to 58 VDC.

Multi-turn and single-turn encoder variants are available. ACOPOSmotor Compact modules are designed for use in harsh environments. With an oil seal, the device corresponds to IP65 protection. It requires neither fans nor heat sinks.

### 3.4.1.2 Decentralized and flexible

In terms of topology, the ACOPOSmotor Compact module is wired either as a simple line structure or as a tree structure. Node number assignment takes place automatically in the line structure. If the address must still be set, however, this can be done without opening the housing.

The connection to the drive system is made using a hybrid connector. This contains all of the power and signal lines needed to operate the ACOPOSmotor Compact module as well as the POWERLINK network.

With the oil seal option, the high IP65 degree of protection allows ACOPOSmotor Compact modules to be mounted directly on the machine. The control cabinet contains only the power supply modules, high-power inverter modules and the necessary electromechanical components. This makes it much easier to implement modular machine architectures and optional machine functions since they can be easily connected – with the requisite dimensioning of the power supply – to the machine's main line using hybrid cables.

The option of connecting X67 modules directly to ACOPOSmotor Compact modules is also ideal for modular machine manufacturing. This opens the door to the implementation of machine modules as production units that can be completed and tested independently.

### 3.4.1.3 Homogeneous and compatible

The ACOPOSmotor Compact module provides the familiar functions of the ACOPOS family and thus fits homogeneously into the drive solution.

### 3.4.1.4 Cooling

ACOPOSmotor Compact modules are self-cooling and have a long, slim design. The modules must be installed on the cooling surface (flange).

### 3.4.1.5 ACOPOSmotor Compact configurations

ACOPOSmotor Compact drive systems have access to multiple technology-specific functions whose performance, flexibility and capability have been remarkably proven in countless applications. The ACOPOSmotor Compact functions listed below are basic functions that the user can switch between as needed within 400  $\mu$ s. In addition, manipulations such as changes in product length, registration mark control, overlying torque control, brief process adaptations and quality checks can be carried out at any time.

- Point-to-point
- Electronic gearbox
- Electronic compensation gears
- Cross cutter
- Electronic cams
- Flying saws
- Line shafts
- CNC

ACOPOSmotor Compact drive systems can be used in various configurations depending on the requirements of the application. The functions listed above are available to the user in each of the topology examples shown.

Reaction speeds are not influenced by the control system being used if technology functions are processed directly on the ACOPOSmotor Compact drive system. Additional sensors and actuators must be integrated in the control system for more complex processes. In these cases, the level of performance depends mostly on the type of network and control system being used. The topology examples shown on the following pages provide an overview of the bandwidths that are possible with B&R automation components.

**Topologies**

**ACOPOSmotor Compact modules do not require an additional servo drive.**

ACOPOSmotor Compact modules do not require an additional servo drive and are simply integrated into the POWERLINK network. Power is supplied via an DC power supply unit.

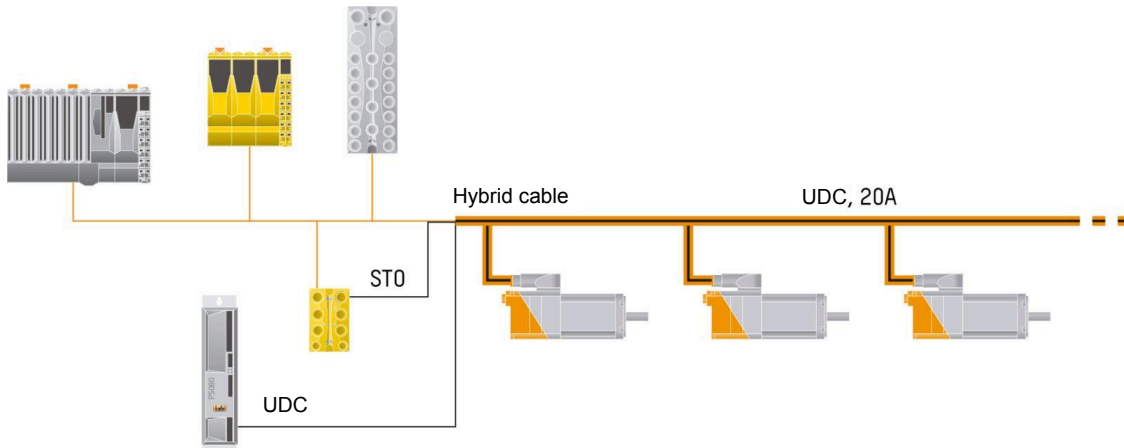

**ACOPOSmotor Compact modules can be integrated into ACOPOSmulti architecture.**

ACOPOSmotor Compact modules can be integrated into ACOPOSmulti architecture. Power is supplied via the DC bus.

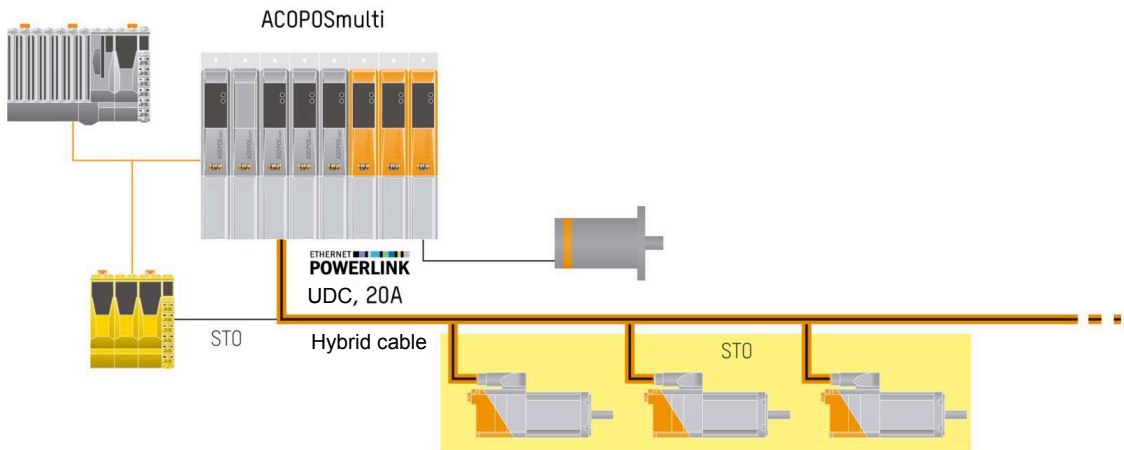

**ACOPOSmotor Compact modules can be connected directly to the ACOPOStrak power supply.**

ACOPOSmotor Compact modules can be connected directly to the ACOPOStrak power supply. This greatly simplifies the wiring of processing stations on the track system. A separate power supply is not necessary for ACOPOSmotor Compact.

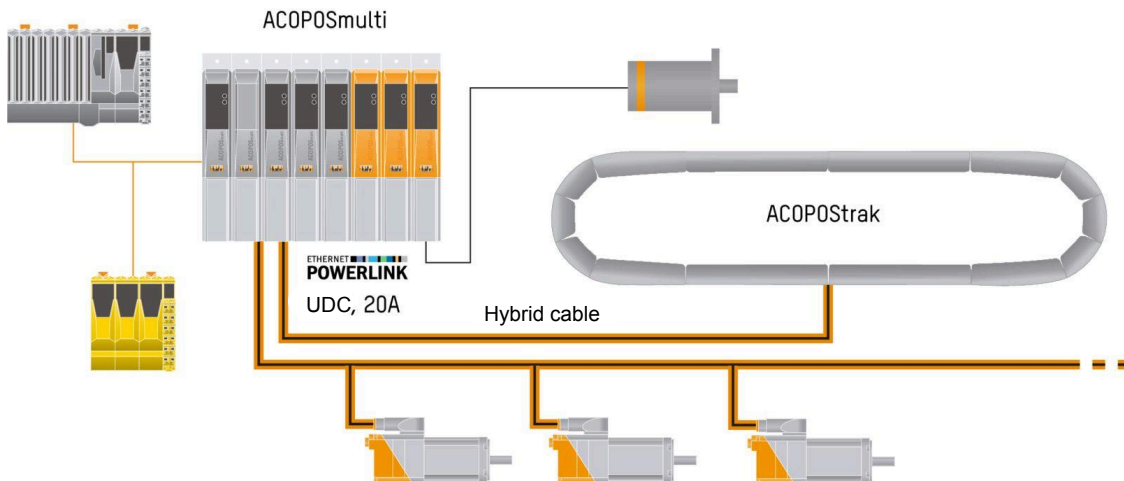

# 4 Technical data

## 4.1 ACOPOSremote

### 4.1.1 Overview

#### Inverter modules (single-axis modules)

Order number	Short description	Page
8CVI045E1HCS0.00-1	ACOPOSremote ACOPOSmulti65 inverter module, 4.5 A, AS, IP65, 1x SinCos EnDat 2.1/SSI/BISS encoder interface, cold plate mounting	39
8CVI045H1HCS0.00-1	ACOPOSremote ACOPOSmulti65 inverter module, 4.5 A, AS, IP65, 1x HIPERFACE encoder interface, cold plate mounting	44
8CVI045S1HCS0.00-1	ACOPOSremote ACOPOSmulti65 inverter module, 4.5 A, AS, IP65, 1x SinCos encoder interface, cold plate mounting	34
8CVI088E1HCS0.00-1	ACOPOSremote ACOPOSmulti65 inverter module, 8.8 A, AS, IP65, 1x SinCos EnDat 2.1/SSI/BISS encoder interface, cold plate mounting	54
8CVI088H1HCS0.00-1	ACOPOSremote ACOPOSmulti65 inverter module, 8.8 A, AS, IP65, 1x HIPERFACE encoder interface, cold plate mounting	59
8CVI088S1HCS0.00-1	ACOPOSremote ACOPOSmulti65 inverter module, 8.8 A, AS, IP65, 1x SinCos encoder interface, cold plate mounting	49
8CVI155S1HCS0.01-1	ACOPOSremote ACOPOSmulti65 inverter module, 15.5 A, AS, IP65, integrated cold plate, 1x SinCos encoder interface, cold plate mounting	64

#### Motor cables

Order number	Short description	Page
8CCM0001.11110-0	ACOPOSremote motor cable, length 1 m, 4x 1.5 mm <sup>2</sup> + 2x 2x 0.75 mm <sup>2</sup> , 8-pin female speedtec motor connector size 1, 8-pin male speedtec servo connector size 1, can be used in cable drag chains	73
8CCM0002.11110-0	ACOPOSremote motor cable, length 2 m, 4x 1.5 mm <sup>2</sup> + 2x 2x 0.75 mm <sup>2</sup> , 8-pin female speedtec motor connector size 1, 8-pin male speedtec servo connector size 1, can be used in cable drag chains	73
8CCM0003.11110-0	ACOPOSremote motor cable, length 3 m, 4x 1.5 mm <sup>2</sup> + 2x 2x 0.75 mm <sup>2</sup> , 8-pin female speedtec motor connector size 1, 8-pin male speedtec servo connector size 1, can be used in cable drag chains	73
8CCM0004.11110-0	ACOPOSremote motor cable, length 4 m, 4x 1.5 mm <sup>2</sup> + 2x 2x 0.75 mm <sup>2</sup> , 8-pin female speedtec motor connector size 1, 8-pin male speedtec servo connector size 1, can be used in cable drag chains	73
8CCM0005.11110-0	ACOPOSremote motor cable, length 5 m, 4x 1.5 mm <sup>2</sup> + 2x 2x 0.75 mm <sup>2</sup> , 8-pin female speedtec motor connector size 1, 8-pin male speedtec servo connector size 1, can be used in cable drag chains	73

#### SinCos cables

Order number	Short description	Page
8CCS0001.11110-0	ACOPOSremote EnDat 2.1 cable, length 1 m, 10x 0.14 mm <sup>2</sup> + 2x 0.5 mm <sup>2</sup> , 12-pin female series 615 signal connector, 15-pin male series 615 signal connector, can be used in cable drag chains	76
8CCS0002.11110-0	ACOPOSremote EnDat 2.1 cable, length 2 m, 10x 0.14 mm <sup>2</sup> + 2x 0.5 mm <sup>2</sup> , 12-pin female series 615 signal connector, 15-pin male series 615 signal connector, can be used in cable drag chains	76
8CCS0003.11110-0	ACOPOSremote EnDat 2.1 cable, length 3 m, 10x 0.14 mm <sup>2</sup> + 2x 0.5 mm <sup>2</sup> , 12-pin female series 615 signal connector, 15-pin male series 615 signal connector, can be used in cable drag chains	76
8CCS0004.11110-0	ACOPOSremote EnDat 2.1 cable, length 4 m, 10x 0.14 mm <sup>2</sup> + 2x 0.5 mm <sup>2</sup> , 12-pin female series 615 signal connector, 15-pin male series 615 signal connector, can be used in cable drag chains	76
8CCS0005.11110-0	ACOPOSremote EnDat 2.1 cable, length 5 m, 10x 0.14 mm <sup>2</sup> + 2x 0.5 mm <sup>2</sup> , 12-pin female series 615 signal connector, 15-pin male series 615 signal connector, can be used in cable drag chains	76

#### EnDat 2.1 cables

Order number	Short description	Page
8CCE0001.11210-0	ACOPOSremote EnDat 2.1 cable, length 1 m, 10x 0.14 mm <sup>2</sup> + 2x 0.5 mm <sup>2</sup> , 17-pin female speedtec motor connector, 15-pin male series 615 signal connector, can be used in cable drag chains	79
8CCE0002.11210-0	ACOPOSremote EnDat 2.1 cable, length 2 m, 10x 0.14 mm <sup>2</sup> + 2x 0.5 mm <sup>2</sup> , 17-pin female speedtec motor connector, 15-pin male series 615 signal connector, can be used in cable drag chains	79
8CCE0003.11210-0	ACOPOSremote EnDat 2.1 cable, length 3 m, 10x 0.14 mm <sup>2</sup> + 2x 0.5 mm <sup>2</sup> , 17-pin female speedtec motor connector, 15-pin male series 615 signal connector, can be used in cable drag chains	79
8CCE0004.11210-0	ACOPOSremote EnDat 2.1 cable, length 4 m, 10x 0.14 mm <sup>2</sup> + 2x 0.5 mm <sup>2</sup> , 17-pin female speedtec motor connector, 15-pin male series 615 signal connector, can be used in cable drag chains	79
8CCE0005.11210-0	ACOPOSremote EnDat 2.1 cable, length 5 m, 10x 0.14 mm <sup>2</sup> + 2x 0.5 mm <sup>2</sup> , 17-pin female speedtec motor connector, 15-pin male series 615 signal connector, can be used in cable drag chains	79

#### Screw sets

Order number	Short description	Page
8CXM000.0000-00	ACOPOSremote accessory set: 4x hex socket screw M6x80mm for 8CVI inverter modules	82
8CXM000.0002-00	ACOPOSremote accessory set: 20x hex socket screw M6x80mm for 8CVI inverter modules	82
8CXM000.0005-00	ACOPOSremote accessory set: 52x hex socket screw M6x80mm for 8CVI inverter modules	82
8CXM000.000A-00	ACOPOSremote accessory set: 100x hex socket screw M6x80mm for 8CVI inverter modules	82

## General accessories

### Connection cables

Order number	Short description	Page
8CCH0005.11120-1	Hybrid cable for connecting 8BVE to 8CVI or 8DI, length 5 m, 2x 2x 0.34 mm <sup>2</sup> + 4x 0.75 mm <sup>2</sup> + 5x 2.5 mm <sup>2</sup> , 1x 15-pin female TYCO connector, 1x RJ45 connector, integrated shield fixing, can be used in cable drag chains	357
8CCH0007.11120-1	Hybrid cable for connecting 8BVE to 8CVI or 8DI, length 7 m, 2x 2x 0.34 mm <sup>2</sup> + 4x 0.75 mm <sup>2</sup> + 5x 2.5 mm <sup>2</sup> , 1x 15-pin female TYCO connector, 1x RJ45 connector, integrated shield fixing, can be used in cable drag chains	357
8CCH0010.11120-1	Hybrid cable for connecting 8BVE to 8CVI or 8DI, length 10 m, 2x 2x 0.34 mm <sup>2</sup> + 4x 0.75 mm <sup>2</sup> + 5x 2.5 mm <sup>2</sup> , 1x 15-pin female TYCO connector, 1x RJ45 connector, integrated shield fixing, can be used in cable drag chains	357
8CCH0015.11120-1	Hybrid cable for connecting 8BVE to 8CVI or 8DI, length 15 m, 2x 2x 0.34 mm <sup>2</sup> + 4x 0.75 mm <sup>2</sup> + 5x 2.5 mm <sup>2</sup> , 1x 15-pin female TYCO connector, 1x RJ45 connector, integrated shield fixing, can be used in cable drag chains	357
8CCH0020.11120-1	Hybrid cable for connecting 8BVE to 8CVI or 8DI, length 20 m, 2x 2x 0.34 mm <sup>2</sup> + 4x 0.75 mm <sup>2</sup> + 5x 2.5 mm <sup>2</sup> , 1x 15-pin female TYCO connector, 1x RJ45 connector, integrated shield fixing, can be used in cable drag chains	357
8CCH0025.11120-1	Hybrid cable for connecting 8BVE to 8CVI or 8DI, length 25 m, 2x 2x 0.34 mm <sup>2</sup> + 4x 0.75 mm <sup>2</sup> + 5x 2.5 mm <sup>2</sup> , 1x 15-pin female TYCO connector, 1x RJ45 connector, integrated shield fixing, can be used in cable drag chains	357

### Hybrid cables

Order number	Short description	Page
8CCH0005.11110-1	Hybrid cable, length 5 m, 2x 2x 0.34 mm <sup>2</sup> + 4x 0.75 mm <sup>2</sup> + 5x 2.5 mm <sup>2</sup> , 2x 15-pin female TYCO connector, can be used in cable drag chains	362
8CCH0007.11110-1	Hybrid cable, length 7 m, 2x 2x 0.34 mm <sup>2</sup> + 4x 0.75 mm <sup>2</sup> + 5x 2.5 mm <sup>2</sup> , 2x 15-pin female TYCO connector, can be used in cable drag chains	362
8CCH0010.11110-1	Hybrid cable, length 10 m, 2x 2x 0.34 mm <sup>2</sup> + 4x 0.75 mm <sup>2</sup> + 5x 2.5 mm <sup>2</sup> , 2x 15-pin female TYCO connector, can be used in cable drag chains	362
8CCH0015.11110-1	Hybrid cable, length 15 m, 2x 2x 0.34 mm <sup>2</sup> + 4x 0.75 mm <sup>2</sup> + 5x 2.5 mm <sup>2</sup> , 2x 15-pin female TYCO connector, can be used in cable drag chains	362
8CCH0020.11110-1	Hybrid cable, length 20 m, 2x 2x 0.34 mm <sup>2</sup> + 4x 0.75 mm <sup>2</sup> + 5x 2.5 mm <sup>2</sup> , 2x 15-pin female TYCO connector, can be used in cable drag chains	362

Order number	Short description	Page
8CCH0001.11130-1	Hybrid cable, length 1 m, 2x 2x 0.34 mm <sup>2</sup> + 4x 0.75 mm <sup>2</sup> + 5x 2.5 mm <sup>2</sup> , 2x 15-pin female TYCO connector, 1x connector insert rotated 180°, can be used in cable drag chains	364
8CCH0002.11130-1	Hybrid cable, length 2 m, 2x 2x 0.34 mm <sup>2</sup> + 4x 0.75 mm <sup>2</sup> + 5x 2.5 mm <sup>2</sup> , 2x 15-pin female TYCO connector, 1x connector insert rotated 180°, can be used in cable drag chains	364
8CCH0003.11130-1	Hybrid cable, length 3 m, 2x 2x 0.34 mm <sup>2</sup> + 4x 0.75 mm <sup>2</sup> + 5x 2.5 mm <sup>2</sup> , 2x 15-pin female TYCO connector, 1x connector insert rotated 180°, can be used in cable drag chains	364
8CCH0004.11130-1	Hybrid cable, length 4 m, 2x 2x 0.34 mm <sup>2</sup> + 4x 0.75 mm <sup>2</sup> + 5x 2.5 mm <sup>2</sup> , 2x 15-pin female TYCO connector, 1x connector insert rotated 180°, can be used in cable drag chains	364
8CCH0005.11130-1	Hybrid cable, length 5 m, 2x 2x 0.34 mm <sup>2</sup> + 4x 0.75 mm <sup>2</sup> + 5x 2.5 mm <sup>2</sup> , 2x 15-pin female TYCO connector, 1x connector insert rotated 180°, can be used in cable drag chains	364

Order number	Short description	Page
8CCH0001.11230-1	Hybrid cable, length 1 m, 2x 2x 0.34 mm <sup>2</sup> + 4x 0.75 mm <sup>2</sup> + 5x 2.5 mm <sup>2</sup> , 2x 15-pin female TYCO connector, connector insert rotated 180°, can be used in cable drag chains	367
8CCH0002.11230-1	Hybrid cable, length 2 m, 2x 2x 0.34 mm <sup>2</sup> + 4x 0.75 mm <sup>2</sup> + 5x 2.5 mm <sup>2</sup> , 2x 15-pin female TYCO connector, connector insert rotated 180°, can be used in cable drag chains	367
8CCH0003.11230-1	Hybrid cable, length 3 m, 2x 2x 0.34 mm <sup>2</sup> + 4x 0.75 mm <sup>2</sup> + 5x 2.5 mm <sup>2</sup> , 2x 15-pin female TYCO connector, connector insert rotated 180°, can be used in cable drag chains	367
8CCH0004.11230-1	Hybrid cable, length 4 m, 2x 2x 0.34 mm <sup>2</sup> + 4x 0.75 mm <sup>2</sup> + 5x 2.5 mm <sup>2</sup> , 2x 15-pin female TYCO connector, connector insert rotated 180°, can be used in cable drag chains	367
8CCH0005.11230-1	Hybrid cable, length 5 m, 2x 2x 0.34 mm <sup>2</sup> + 4x 0.75 mm <sup>2</sup> + 5x 2.5 mm <sup>2</sup> , 2x 15-pin female TYCO connector, connector insert rotated 180°, can be used in cable drag chains	367

Order number	Short description	Page
8CCH0005.11220-1	Hybrid cable for connecting 8BVE to 8CVI or 8DI, length 5 m, 2x 2x 0.34 mm <sup>2</sup> + 4x 0.75 mm <sup>2</sup> + 5x 2.5 mm <sup>2</sup> , 1x 15-pin female TYCO connector, connector insert rotated 180°, can be used in cable drag chains	370
8CCH0007.11220-1	Hybrid cable for connecting 8BVE to 8CVI or 8DI, length 7 m, 2x 2x 0.34 mm <sup>2</sup> + 4x 0.75 mm <sup>2</sup> + 5x 2.5 mm <sup>2</sup> , 1x 15-pin female TYCO connector, connector insert rotated 180°, can be used in cable drag chains	370
8CCH0010.11220-1	Hybrid cable for connecting 8BVE to 8CVI or 8DI, length 10 m, 2x 2x 0.34 mm <sup>2</sup> + 4x 0.75 mm <sup>2</sup> + 5x 2.5 mm <sup>2</sup> , 1x 15-pin female TYCO connector, connector insert rotated 180°, can be used in cable drag chains	370
8CCH0015.11220-1	Hybrid cable for connecting 8BVE to 8CVI or 8DI, length 15 m, 2x 2x 0.34 mm <sup>2</sup> + 4x 0.75 mm <sup>2</sup> + 5x 2.5 mm <sup>2</sup> , 1x 15-pin female TYCO connector, connector insert rotated 180°, can be used in cable drag chains	370
8CCH0020.11220-1	Hybrid cable for connecting 8BVE to 8CVI or 8DI, length 20 m, 2x 2x 0.34 mm <sup>2</sup> + 4x 0.75 mm <sup>2</sup> + 5x 2.5 mm <sup>2</sup> , 1x 15-pin female TYCO connector, connector insert rotated 180°, can be used in cable drag chains	370

### Slot covers / Threaded caps

Order number	Short description	Page
8XC000.0000-00	Accessory set: 1x slot cover for hybrid connector	377
X67AC0M08	X67 M8 threaded caps, 50 pcs.	378
X67AC0M12	X67 M12 threaded caps, 50 pcs.	378

## 4.1.2 Inverter modules

### 4.1.2.1 Status indicators

#### 8CVI045x1HCS0.00-1

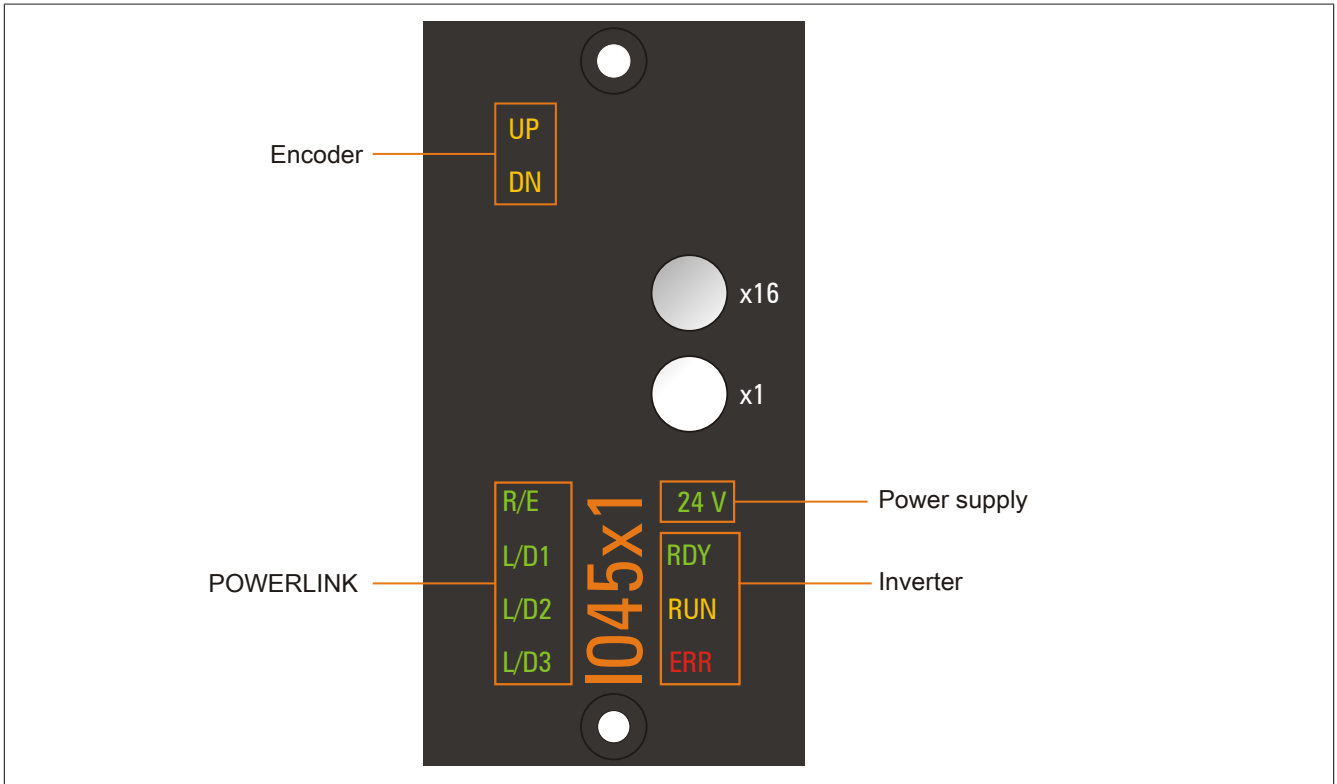

Figure 10: 8CVI045x1HCS0.00-1 - Display group overview

#### 8CVI088x1HCS0.00-1

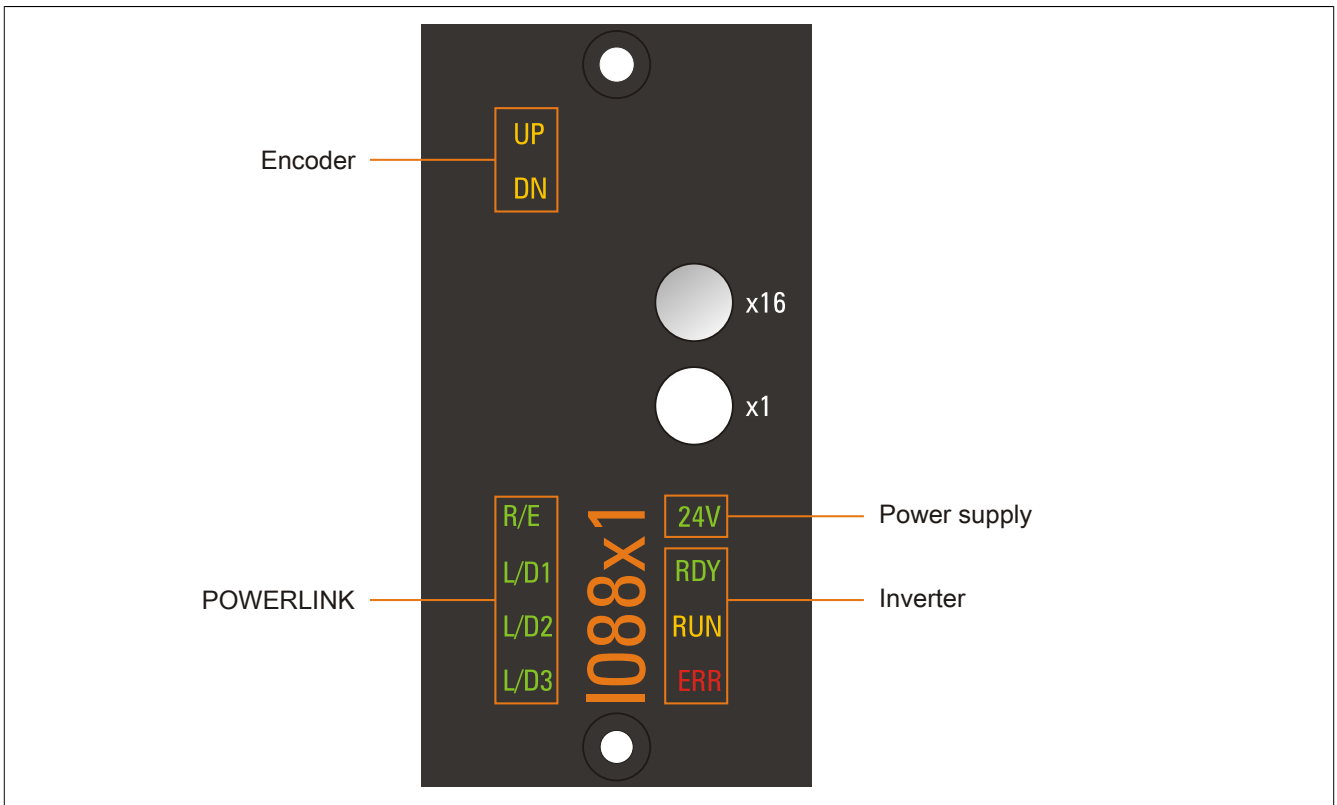

Figure 11: 8CVI088x1HCS0.00-1 - Display group overview

8CVI155S1HCS0.01-1

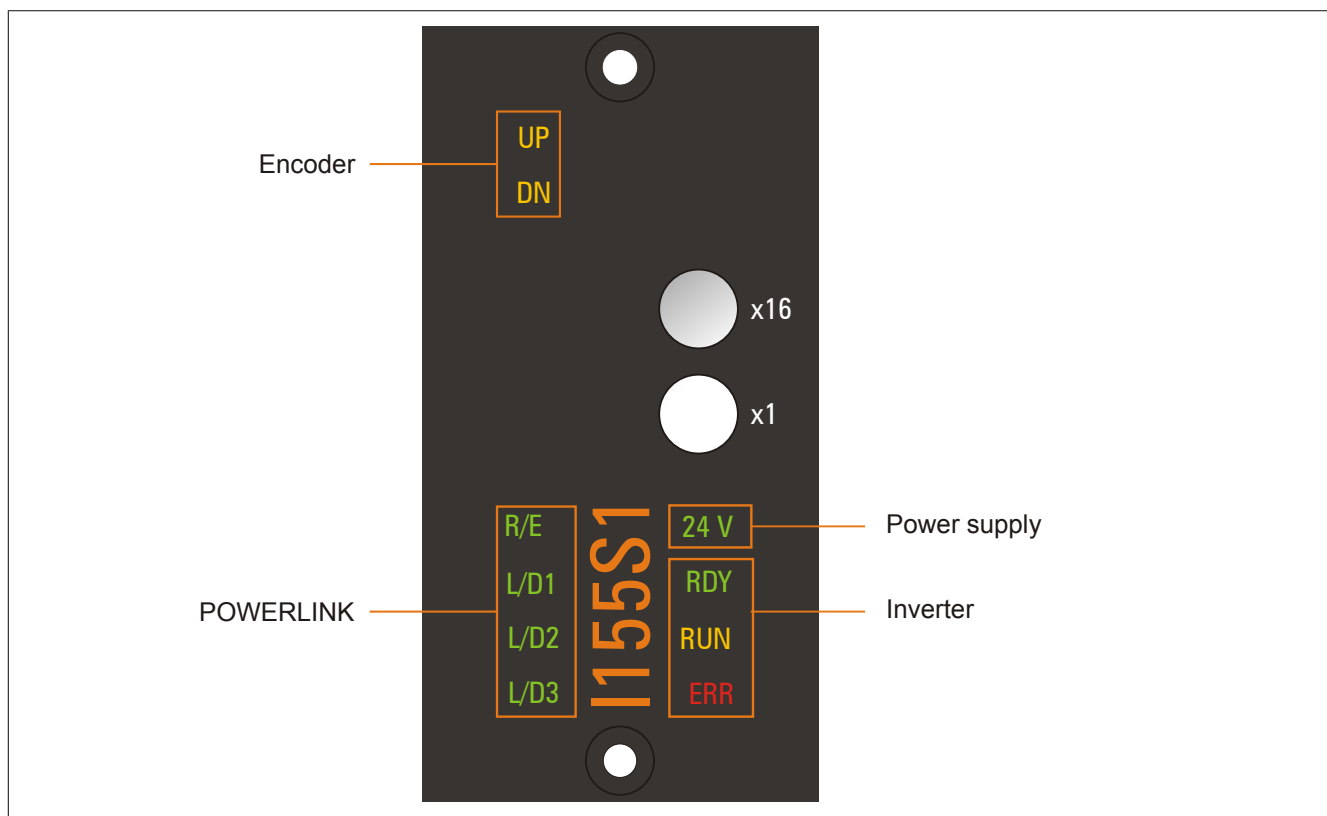

Figure 12: Status indicator group 8CVI155S1HCS0.01-1 - Overview

### 4.1.2.1.1 LED status indicators

Status indicator group	Label	Color	Function	Description
POWERLINK	R/E	Green/Red	Ready/Error	see Tab. 2 "POWERLINK - LED status indicators" on page 33
	L/D1	Green	Link/Data activity on port 1	
	L/D2	Green	Link/Data activity on port 2	
	L/D3	Green	Link/Data activity on port 3	
Power inverter	RDY	Green	Ready	see Tab. 3 "RDY, RUN, ERR - LED status indicators" on page 33
	RUN	Orange	Run	
	ERR	Red	Error	
Power supply	24 V	Green	24 V OK	24 VDC module voltage supply is within the tolerance range.
Encoder	UP	Orange	Encoder direction of rotation +	Indicates that the position of the connected encoder is changing in the positive direction. The faster the encoder position changes, the brighter the LED is lit.
	DN	Orange	Encoder direction of rotation -	Indicates that the position of the connected encoder is changing in the negative direction. The faster the encoder position changes, the brighter the LED is lit.

Table 1: 8CVI inverter modules - LED status indicators

### 4.1.2.1.2 POWERLINK - LED status indicators

Label	Color	Function	Description	
R/E	Green/Red	Ready/Error	LED off	The module is not receiving power or initialization of the network interface has failed.
			Solid red	The POWERLINK node number of the module is 0.
			Blinking red/green	The client is in an error state (drops out of cyclic operation).
			Blinking green (1x)	The client detects a valid POWERLINK frame on the network.
			Blinking green (2x)	Cyclic operation on the network is taking place, but the client itself is not yet a participant.
			Blinking green (3x)	Cyclic operation of the client is in preparation.
			Solid green	The client is participating in cyclic operation.
			Flickering green	The client is not participating in cyclic operation and also does not detect any other stations on the network participating in cyclic operation.
L/D1	Green	Link/Data activity on port 1	Solid green	A physical connection has been established to another station on the network.
L/D2	Green	Link/Data activity on port 2	Solid green	A physical connection has been established to another station on the network.
L/D3	Green	Link/Data activity on port 3	Solid green	A physical connection has been established to another station on the network.

Table 2: POWERLINK - LED status indicators

### 4.1.2.1.3 RDY, RUN, ERR - LED status indicators

Label	Color	Function	Description	
RDY	Green	Ready	Solid green	The module is operational and the power stage can be enabled (operating system present and booted, no permanent or temporary errors).
			Blinking green <sup>1)</sup>	The module is not ready for operation.  Examples: <ul style="list-style-type: none"> <li>No signal on one or both enable inputs</li> <li>DC bus voltage outside the tolerance range</li> <li>Overtemperature on the motor (temperature sensor)</li> <li>Motor feedback not connected or defective</li> <li>Motor temperature sensor not connected or defective</li> <li>Overtemperature on the module (IGBT junction, heat sink, etc.)</li> <li>Disturbance on network</li> </ul>
RUN	Orange	Run	Solid orange	The module's power stage is enabled.
ERR	Red	Error	Solid red <sup>1)</sup>	There is a permanent error on the module.  Examples: <ul style="list-style-type: none"> <li>Permanent overcurrent</li> <li>Invalid data in EPROM</li> </ul>

Table 3: RDY, RUN, ERR - LED status indicators

1) Firmware V2.130 and later.

### 4.1.2.2 8CVI045S1HCS0.00-1

#### 4.1.2.2.1 Order data

Order number	Short description	Figure
	<b>ACOPOSremote inverter units</b>	
8CVI045S1HCS0.00-1	ACOPOSremote ACOPOSmulti65 inverter module, 4.5 A, AS, IP65, 1x SinCos encoder interface, cold plate mounting	
	<b>Optional accessories</b>	
	<b>1.5 mm² motor cables</b>	
8CCM0003.11110-0	ACOPOSremote motor cable, length 3 m, 4x 1.5 mm² + 2x 2x 0.75 mm², 8-pin female speedtec motor connector size 1, 8-pin male speedtec servo connector size 1, can be used in cable drag chains	
8CCM0005.11110-0	ACOPOSremote motor cable, length 5 m, 4x 1.5 mm² + 2x 2x 0.75 mm², 8-pin female speedtec motor connector size 1, 8-pin male speedtec servo connector size 1, can be used in cable drag chains	
8CCM0010.11110-0	ACOPOSremote motor cable, length 10 m, 4x 1.5 mm² + 2x 2x 0.75 mm², 8-pin female speedtec motor connector size 1, 8-pin male speedtec servo connector size 1, can be used in cable drag chains	
8CCM0015.11110-0	ACOPOSremote motor cable, length 15 m, 4x 1.5 mm² + 2x 2x 0.75 mm², 8-pin female speedtec motor connector size 1, 8-pin male speedtec servo connector size 1, can be used in cable drag chains	
	<b>8BVE / 8CVI connection cables</b>	
8CCH0005.11120-1	Hybrid cable for connecting 8BVE to 8CVI or 8DI, length 5 m, 2x 2x 0.34 mm² + 4x 0.75 mm² + 5x 2.5 mm², 1x 15-pin female TYCO connector, 1x RJ45 connector, integrated shield fixing, can be used in cable drag chains	
8CCH0007.11120-1	Hybrid cable for connecting 8BVE to 8CVI or 8DI, length 7 m, 2x 2x 0.34 mm² + 4x 0.75 mm² + 5x 2.5 mm², 1x 15-pin female TYCO connector, 1x RJ45 connector, integrated shield fixing, can be used in cable drag chains	
8CCH0010.11120-1	Hybrid cable for connecting 8BVE to 8CVI or 8DI, length 10 m, 2x 2x 0.34 mm² + 4x 0.75 mm² + 5x 2.5 mm², 1x 15-pin female TYCO connector, 1x RJ45 connector, integrated shield fixing, can be used in cable drag chains	
	<b>Accessory sets</b>	
8CXC000.0000-00	Accessory set: 1x slot cover for hybrid connector	
8CXM000.0000-00	ACOPOSremote accessory set: 4x hex socket screw M6x80mm for 8CVI inverter modules	
	<b>Hybrid cables</b>	
8CCH0003.11110-1	Hybrid cable, length 3 m, 2x 2x 0.34 mm² + 4x 0.75 mm² + 5x 2.5 mm², 2x 15-pin female TYCO connector, can be used in cable drag chains	
8CCH0003.11130-1	Hybrid cable, length 3 m, 2x 2x 0.34 mm² + 4x 0.75 mm² + 5x 2.5 mm², 2x 15-pin female TYCO connector, 1x connector insert rotated 180°, can be used in cable drag chains	
8CCH0005.11110-1	Hybrid cable, length 5 m, 2x 2x 0.34 mm² + 4x 0.75 mm² + 5x 2.5 mm², 2x 15-pin female TYCO connector, can be used in cable drag chains	
8CCH0010.11110-1	Hybrid cable, length 10 m, 2x 2x 0.34 mm² + 4x 0.75 mm² + 5x 2.5 mm², 2x 15-pin female TYCO connector, can be used in cable drag chains	
8CCH0015.11110-1	Hybrid cable, length 15 m, 2x 2x 0.34 mm² + 4x 0.75 mm² + 5x 2.5 mm², 2x 15-pin female TYCO connector, can be used in cable drag chains	
8CCH0020.11110-1	Hybrid cable, length 20 m, 2x 2x 0.34 mm² + 4x 0.75 mm² + 5x 2.5 mm², 2x 15-pin female TYCO connector, can be used in cable drag chains	
	<b>One-sided hybrid cables</b>	
8CCH0005.11150-1	Hybrid cable for connecting 8EI to 8CVI or 8DI, length 5 m, 2x 2x 0.34 mm² + 4x 0.75 mm² + 5x 2.5 mm², 1x 15-pin female TYCO connector, 1x RJ45 connector, integrated shield fixing, can be used in cable drag chains	
8CCH0007.11150-1	Hybrid cable for connecting 8EI to 8CVI or 8DI, length 7 m, 2x 2x 0.34 mm² + 4x 0.75 mm² + 5x 2.5 mm², 1x 15-pin female TYCO connector, 1x RJ45 connector, integrated shield fixing, can be used in cable drag chains	
8CCH0010.11150-1	Hybrid cable for connecting 8EI to 8CVI or 8DI, length 10 m, 2x 2x 0.34 mm² + 4x 0.75 mm² + 5x 2.5 mm², 1x 15-pin female TYCO connector, 1x RJ45 connector, integrated shield fixing, can be used in cable drag chains	
8CCH0015.11150-1	Hybrid cable for connecting 8EI to 8CVI or 8DI, length 15 m, 2x 2x 0.34 mm² + 4x 0.75 mm² + 5x 2.5 mm², 1x 15-pin female TYCO connector, 1x RJ45 connector, integrated shield fixing, can be used in cable drag chains	

Table 4: 8CVI045S1HCS0.00-1 - Order data

Order number	Short description	Figure
8CCH0020.11150-1	Hybrid cable for connecting 8EI to 8CVI or 8DI, length 20 m, 2x 2x 0.34 mm <sup>2</sup> + 4x 0.75 mm <sup>2</sup> + 5x 2.5 mm <sup>2</sup> , 1x 15-pin female TYCO connector, 1x RJ45 connector, integrated shield fixing, can be used in cable drag chains	
8CCH0025.11150-1	Hybrid cable for connecting 8EI to 8CVI or 8DI, length 25 m, 2x 2x 0.34 mm <sup>2</sup> + 4x 0.75 mm <sup>2</sup> + 5x 2.5 mm <sup>2</sup> , 1x 15-pin female TYCO connector, 1x RJ45 connector, integrated shield fixing, can be used in cable drag chains	
<b>SinCos cables</b>		
8CCS0003.11110-0	ACOPOSremote EnDat 2.1 cable, length 3 m, 10x 0.14 mm <sup>2</sup> + 2x 0.5 mm <sup>2</sup> , 12-pin female series 615 signal connector, 15-pin male series 615 signal connector, can be used in cable drag chains	
8CCS0005.11110-0	ACOPOSremote EnDat 2.1 cable, length 5 m, 10x 0.14 mm <sup>2</sup> + 2x 0.5 mm <sup>2</sup> , 12-pin female series 615 signal connector, 15-pin male series 615 signal connector, can be used in cable drag chains	
8CCS0010.11110-0	ACOPOSremote EnDat 2.1 cable, length 10 m, 10x 0.14 mm <sup>2</sup> + 2x 0.5 mm <sup>2</sup> , 12-pin female series 615 signal connector, 15-pin male series 615 signal connector, can be used in cable drag chains	
8CCS0015.11110-0	ACOPOSremote EnDat 2.1 cable, length 15 m, 10x 0.14 mm <sup>2</sup> + 2x 0.5 mm <sup>2</sup> , 12-pin female series 615 signal connector, 15-pin male series 615 signal connector, can be used in cable drag chains	
<b>Threaded caps</b>		
X67AC0M08	X67 M8 threaded caps, 50 pcs.	
X67AC0M12	X67 M12 threaded caps, 50 pcs.	

Table 4: 8CVI045S1HCS0.00-1 - Order data

#### 4.1.2.2.2 Technical data

Order number	8CVI045S1HCS0.00-1
<b>General information</b>	
Module type	ACOPOSremote module
B&R ID code	0xB5CB
Current-carrying capacity of 15-pin TYCO connector	
Power contacts	Max. 20 A at 40°C
Cooling and mounting type	Cold plate mounting
Certifications	
CE	Yes
Functional safety <sup>1)</sup>	Yes
UL	cULus E225616 Power conversion equipment
KC	Yes
<b>DC bus connection</b>	
Voltage	
Nominal	750 VDC
Continuous power consumption <sup>2)</sup>	In preparation
Power dissipation depending on switching frequency	
Switching frequency 5 kHz	$[0.16 * I_M^2 + 5.6 * I_M + 55 + (P_{out}/750)^2 * 0.25]$ W
Switching frequency 10 kHz	$[0.49 * I_M^2 + 4.7 * I_M + 95 + (P_{out}/750)^2 * 0.25]$ W
Switching frequency 20 kHz	$[0.87 * I_M^2 + 10 * I_M + 200 + (P_{out}/750)^2 * 0.25]$ W
DC bus capacitance	35 µF
Variant	15-pin male TYCO connector <sup>3)</sup>
Line length	
Maximum	30 m
<b>24 VDC power supply</b>	
Input voltage	24 VDC +20% / -25%
Input capacitance	In preparation
Max. power consumption	$10 \text{ W} + P_{24 \text{ V out}} + P_{\text{Holding brake}} + P_{\text{Trigger}}^4)$
Variant	15-pin male TYCO connector <sup>3)</sup>
Line length	
Maximum	30 m
<b>24 VDC output</b>	
Quantity	1
Output voltage	Depends on the 24 VDC power supply
Continuous current	Max. 8 A (max. 4 A per pin)
Fuse protection	Electronic (per pin)
Variant	
24 VDC, COM	M8 connector
<b>Motor connection</b>	
Quantity	1
Continuous power per motor connection <sup>2)</sup>	1.5 kW

Table 5: 8CVI045S1HCS0.00-1 - Technical data

## Technical data

Order number	8CVI045S1HCS0.00-1
Continuous current per motor connection <sup>2)</sup>	4.5 A <sub>eff</sub>
Reduction of continuous current depending on switching frequency <sup>5)</sup>	
Switching frequency 5 kHz	No reduction <sup>6)</sup>
Switching frequency 10 kHz	No reduction
Switching frequency 20 kHz	No reduction
Reduction of continuous current depending on installation elevation	
Starting at 500 m above sea level	0.45 A per 1,000 m
Peak current	13.5 A <sub>eff</sub>
Nominal switching frequency	5 kHz
Possible switching frequencies <sup>7)</sup>	5 / 10 / 20 kHz
Insulation stress of the connected motor per IEC TS 60034-25:2004 <sup>8)</sup>	Limit value curve A
Protective measures	
Overload protection	Yes
Short-circuit and ground fault protection	Yes
Max. output frequency	598 Hz <sup>9)</sup>
Variant	
U, V, W, PE	8-pin speedtec connector, size 1
Shield connection	Yes (via connector housing)
Max. motor line length depending on switching frequency	
Switching frequency 5 kHz	10 m
Switching frequency 10 kHz	5 m
Switching frequency 20 kHz	5 m
<b>Motor holding brake connection</b>	
Quantity	1
Output voltage <sup>10)</sup>	24 VDC +5.8% / -0%
Continuous current per connection	1.1 A
Max. internal resistance	In preparation
Extinction potential	Approx. 30 V
Max. extinction energy per switching operation	1.5 Ws
Max. switching frequency	0.5 Hz
Protective measures	
Overload and short-circuit protection	Yes
Open-circuit monitoring	Yes
Undervoltage monitoring	Yes
Response threshold for open-circuit monitoring	Approx. 0.25 A
Response threshold for undervoltage monitoring	24 VDC +0% / -4%
<b>Fieldbus</b>	
Type	POWERLINK (V1/V2) 100BASE-T (ANSI/IEE 802.3)
Variant	Internal 3-port hub, 2x male 15-pin TYCO connector, 1x M12 connector
Line length	Max. 100 m between two stations (segment length) <sup>11)</sup>
Transfer rate	100 Mbit/s
<b>Encoder inputs</b>	
Quantity	1
Type	SinCos
Module-side connection	15-pin female springtec connector
Status indicators	UP/DN LEDs
Electrical isolation	
Encoder - ACOPOSremote	No
Encoder monitoring	Yes
Max. encoder cable length	10 m
Encoder power supply	
Output voltage	5 V ±5%
Load capacity	300 mA <sup>12)</sup>
Sense lines	2, compensation of max. 2 x 0.7 V
Protective measures	
Overload-proof	Yes
Short-circuit proof	Yes
Sine/Cosine inputs	
Signal transmission	Differential signals, symmetrical
Signal frequency (-3 dB)	DC up to 300 kHz
Signal frequency (-5 dB)	DC up to 400 kHz
Differential voltage	0.5 to 1.25 V <sub>ss</sub>
Common-mode voltage	Max. ±7 V
Terminating resistor	120 Ω
ADC resolution	12-bit

Table 5: 8CVI045S1HCS0.00-1 - Technical data

Order number	8CVI045S1HCS0.00-1
Reference input	
Signal transmission	Differential signal, symmetrical
Differential voltage for low	$\leq -0.2$ V
Differential voltage for high	$\geq 0.2$ V
Common-mode voltage	Max. $\pm 7$ V
Terminating resistor	120 $\Omega$
Position	
Resolution @ 1 V <sub>SS</sub> <sup>13)</sup>	Number of encoder lines * 5700
Accuracy <sup>14)</sup>	-
Noise <sup>14)</sup>	-
Limit switch inputs <sup>15)</sup>	
Quantity	2
Circuit	Source
Input resistance	1470 $\Omega$
Electrical isolation	
Input - ACOPOSremote	No
Input - Input	No
Input voltage	
Minimum	-12 V
Nominal	5 V
Maximum	20 V
Switching threshold	
Low	<0.8 V
High	>2 V
Switching delay	Max. 100 $\mu$ s
<b>Enable inputs</b>	
Quantity	2
Circuit	Sink
Electrical isolation	
Input - Inverter module	Yes
Input - Input	Yes
Input voltage	
Nominal	24 VDC
Maximum	30 VDC
Input current at nominal voltage	Approx. 30 mA
Switching threshold	
Low	<5 V
High	>15 V
Switching delay at nominal input voltage	
Enable 1 $\rightarrow$ 0, PWM off	Max. 20.5 ms
Enable 0 $\rightarrow$ 1, ready for PWM	Max. 100 $\mu$ s
Modulation compared to ground potential	Max. $\pm 38$ V
OSSD signal connections <sup>16)</sup>	Permitted Max. test pulse length: 500 $\mu$ s
Variant	15-pin male TYCO connector <sup>3)</sup>
<b>Trigger inputs</b>	
Quantity	2
Circuit	Sink
Electrical isolation	
Input - Inverter module	No
Input - Input	No
Input voltage	
Nominal	24 VDC
Maximum	30 VDC
Switching threshold	
Low	<5 V
High	>15 V
Input current at nominal voltage	In preparation
Switching delay	
Rising edge	In preparation
Falling edge	In preparation
Modulation compared to ground potential	In preparation
Max. line length	30 m
Variant	M8 connector
Sensor/Actuator power supply	
Voltage	24 VDC
Summation current	Max. 250 mA <sup>17)</sup>
<b>Temperature sensor connection</b>	
Quantity	1
Resistance range	500 $\Omega$ to 5 k $\Omega$
<b>Support</b>	
Software	
ACP10	V2.35.1 and higher

Table 5: 8CVI045S1HCS0.00-1 - Technical data

## Technical data

Order number	8CVI045S1HCS0.00-1
<b>Electrical properties</b>	
Discharge capacitance	0.1 µF
<b>Operating conditions</b>	
Permissible mounting orientations	
Hanging vertically	Yes
Horizontal, face up	Yes
Standing horizontally	Yes
Installation elevation above sea level	
Nominal	0 to 500 m
Maximum <sup>18)</sup>	4000 m
Pollution degree per EN 61800-5-1	2 (non-conductive pollution)
Overvoltage category per EN 61800-5-1	III
Degree of protection per EN 60529	IP65 <sup>19)</sup>
<b>Ambient conditions</b>	
Temperature	
Operation	
Nominal	5 to 40°C <sup>20)</sup>
Maximum	60°C
Storage	-25 to 55°C
Transport	-25 to 70°C
Relative humidity	
Operation	5 to 85%, non-condensing
Storage	5 to 95%, non-condensing
Transport	Max. 95% at 40°C
<b>Mechanical properties</b>	
Dimensions <sup>21)</sup>	
Width	137 mm
Height	287.2 mm
Depth	131 mm
Weight	4.8 kg

Table 5: 8CVI045S1HCS0.00-1 - Technical data

- 1) Achievable safety classifications (safety integrity level, safety category, performance level) are documented in the user's manual (section "Safety technology").
- 2) Valid under the following conditions: 750 VDC DC bus voltage, 5 kHz switching frequency, 40°C ambient temperature, installation elevation <500 m above sea level, no derating due to cooling type.
- 3) It is important to note that the 15-pin male TYCO connector is designed for max. 20 mating cycles.
- 4) The power consumption  $P_{24V\ Out}$  corresponds to the portion of the power that is output on the X31 connector on the module.
- 5) Valid under the following conditions: 750 VDC DC bus voltage. The temperature specifications refer to the ambient temperature.
- 6) Value for the nominal switching frequency.
- 7) B&R recommends operating the module at its nominal switching frequency. Operating the module at a higher switching frequency for application-specific reasons reduces the continuous current and increases CPU utilization.
- 8) If necessary, the stress of the motor isolation system can be reduced by an additional externally wired dv/dt choke. For example, the RWK 305 three-phase dv/dt choke from Schaffner ([www.schaffner.com](http://www.schaffner.com)) can be used. IMPORTANT: Even when using a dv/dt choke, it is necessary to ensure that an EMC-compatible, low inductance shield connection is used!
- 9) The module's electrical output frequency (SCTRL\_SPEED\_ACT \* MOTOR\_POLEPAIRS) is monitored to protect against dual use in accordance with Regulation (EC) 428/2009 | 3A225. If the electrical output frequency of the module exceeds the limit value of 598 Hz uninterrupted for more than 0.5 s, then the current movement is aborted and error 6060 is output ("Power unit: Limit speed exceeded").
- 10) During configuration, it is necessary to check if the minimum voltage can be maintained on the holding brake with the intended wiring. For the operating voltage range of the holding brake, see the user documentation for the motor being used.
- 11) Limited to 30 m when using hybrid cables.
- 12) An additional reserve of 12 mA exists for terminating resistors and limit switch inputs.
- 13) This value does not correspond to the encoder resolution that must be configured in Automation Studio (16384 \* number of encoder lines).
- 14) Limited by the encoder in practice.
- 15) The measurement system offered by Heidenhain with limit switch outputs LIDA 47x, LIDA 48x and LIF4x1 was tested for compatibility. In practice, the cable length is limited by the encoder.
- 16) Output signal switching device (OSSD) signals are used for monitoring signal lines for short circuits and cross faults.
- 17) The summation current corresponds to the current that is output on the X23A and X24A connectors on the module.
- 18) Continuous operation at an installation elevation of 500 m to 4,000 m above sea level is possible taking the specified reduction of continuous current into account. Requirements that go beyond this must be arranged with B&R.
- 19) The specified degree of protection is only met if all connectors on the module that are not being used are closed with suitable threaded caps or slot covers! Suitable threaded caps or slot covers are available as optional accessories (X67AC0M08, X67AC0M12, 8CXC000.0000-00). The module is delivered with IP20 protection.
- 20) The temperature of the module's mounting surface is not permitted to exceed 60°C.
- 21) The dimensions refer to the actual device dimensions. Additional spacing above and below the devices must be taken into account for mounting and connection.

4.1.2.3 8CVI045E1HCS0.00-1

4.1.2.3.1 Order data

Order number	Short description	Figure
<b>ACOPOSremote inverter units</b>		
8CVI045E1HCS0.00-1	ACOPOSremote ACOPOSmulti65 inverter module, 4.5 A, AS, IP65, 1x SinCos EnDat 2.1/SSI/BiSS encoder interface, cold plate mounting	
<b>Optional accessories</b>		
<b>1.5 mm² motor cables</b>		
8CCM0003.11110-0	ACOPOSremote motor cable, length 3 m, 4x 1.5 mm² + 2x 2x 0.75 mm², 8-pin female speedtec motor connector size 1, 8-pin male speedtec servo connector size 1, can be used in cable drag chains	
8CCM0005.11110-0	ACOPOSremote motor cable, length 5 m, 4x 1.5 mm² + 2x 2x 0.75 mm², 8-pin female speedtec motor connector size 1, 8-pin male speedtec servo connector size 1, can be used in cable drag chains	
8CCM0010.11110-0	ACOPOSremote motor cable, length 10 m, 4x 1.5 mm² + 2x 2x 0.75 mm², 8-pin female speedtec motor connector size 1, 8-pin male speedtec servo connector size 1, can be used in cable drag chains	
8CCM0015.11110-0	ACOPOSremote motor cable, length 15 m, 4x 1.5 mm² + 2x 2x 0.75 mm², 8-pin female speedtec motor connector size 1, 8-pin male speedtec servo connector size 1, can be used in cable drag chains	
<b>8BVE / 8CVI connection cables</b>		
8CCH0005.11120-1	Hybrid cable for connecting 8BVE to 8CVI or 8DI, length 5 m, 2x 2x 0.34 mm² + 4x 0.75 mm² + 5x 2.5 mm², 1x 15-pin female TYCO connector, 1x RJ45 connector, integrated shield fixing, can be used in cable drag chains	
8CCH0007.11120-1	Hybrid cable for connecting 8BVE to 8CVI or 8DI, length 7 m, 2x 2x 0.34 mm² + 4x 0.75 mm² + 5x 2.5 mm², 1x 15-pin female TYCO connector, 1x RJ45 connector, integrated shield fixing, can be used in cable drag chains	
8CCH0010.11120-1	Hybrid cable for connecting 8BVE to 8CVI or 8DI, length 10 m, 2x 2x 0.34 mm² + 4x 0.75 mm² + 5x 2.5 mm², 1x 15-pin female TYCO connector, 1x RJ45 connector, integrated shield fixing, can be used in cable drag chains	
<b>Accessory sets</b>		
8CXC000.0000-00	Accessory set: 1x slot cover for hybrid connector	
8CXM000.0000-00	ACOPOSremote accessory set: 4x hex socket screw M6x80mm for 8CVI inverter modules	
<b>EnDat 2.1 cables</b>		
8CCE0003.11210-0	ACOPOSremote EnDat 2.1 cable, length 3 m, 10x 0.14 mm² + 2x 0.5 mm², 17-pin female speedtec motor connector, 15-pin male series 615 signal connector, can be used in cable drag chains	
8CCE0005.11210-0	ACOPOSremote EnDat 2.1 cable, length 5 m, 10x 0.14 mm² + 2x 0.5 mm², 17-pin female speedtec motor connector, 15-pin male series 615 signal connector, can be used in cable drag chains	
<b>Hybrid cables</b>		
8CCH0003.11110-1	Hybrid cable, length 3 m, 2x 2x 0.34 mm² + 4x 0.75 mm² + 5x 2.5 mm², 2x 15-pin female TYCO connector, can be used in cable drag chains	
8CCH0003.11130-1	Hybrid cable, length 3 m, 2x 2x 0.34 mm² + 4x 0.75 mm² + 5x 2.5 mm², 2x 15-pin female TYCO connector, 1x connector insert rotated 180°, can be used in cable drag chains	
8CCH0005.11110-1	Hybrid cable, length 5 m, 2x 2x 0.34 mm² + 4x 0.75 mm² + 5x 2.5 mm², 2x 15-pin female TYCO connector, can be used in cable drag chains	
8CCH0010.11110-1	Hybrid cable, length 10 m, 2x 2x 0.34 mm² + 4x 0.75 mm² + 5x 2.5 mm², 2x 15-pin female TYCO connector, can be used in cable drag chains	
8CCH0015.11110-1	Hybrid cable, length 15 m, 2x 2x 0.34 mm² + 4x 0.75 mm² + 5x 2.5 mm², 2x 15-pin female TYCO connector, can be used in cable drag chains	
8CCH0020.11110-1	Hybrid cable, length 20 m, 2x 2x 0.34 mm² + 4x 0.75 mm² + 5x 2.5 mm², 2x 15-pin female TYCO connector, can be used in cable drag chains	
<b>One-sided hybrid cables</b>		
8CCH0005.11150-1	Hybrid cable for connecting 8EI to 8CVI or 8DI, length 5 m, 2x 2x 0.34 mm² + 4x 0.75 mm² + 5x 2.5 mm², 1x 15-pin female TYCO connector, 1x RJ45 connector, integrated shield fixing, can be used in cable drag chains	
8CCH0007.11150-1	Hybrid cable for connecting 8EI to 8CVI or 8DI, length 7 m, 2x 2x 0.34 mm² + 4x 0.75 mm² + 5x 2.5 mm², 1x 15-pin female TYCO connector, 1x RJ45 connector, integrated shield fixing, can be used in cable drag chains	

Table 6: 8CVI045E1HCS0.00-1 - Order data

## Technical data

Order number	Short description	Figure
8CCH0010.11150-1	Hybrid cable for connecting 8EI to 8CVI or 8DI, length 10 m, 2x 2x 0.34 mm <sup>2</sup> + 4x 0.75 mm <sup>2</sup> + 5x 2.5 mm <sup>2</sup> , 1x 15-pin female TYCO connector, 1x RJ45 connector, integrated shield fixing, can be used in cable drag chains	
8CCH0015.11150-1	Hybrid cable for connecting 8EI to 8CVI or 8DI, length 15 m, 2x 2x 0.34 mm <sup>2</sup> + 4x 0.75 mm <sup>2</sup> + 5x 2.5 mm <sup>2</sup> , 1x 15-pin female TYCO connector, 1x RJ45 connector, integrated shield fixing, can be used in cable drag chains	
8CCH0020.11150-1	Hybrid cable for connecting 8EI to 8CVI or 8DI, length 20 m, 2x 2x 0.34 mm <sup>2</sup> + 4x 0.75 mm <sup>2</sup> + 5x 2.5 mm <sup>2</sup> , 1x 15-pin female TYCO connector, 1x RJ45 connector, integrated shield fixing, can be used in cable drag chains	
8CCH0025.11150-1	Hybrid cable for connecting 8EI to 8CVI or 8DI, length 25 m, 2x 2x 0.34 mm <sup>2</sup> + 4x 0.75 mm <sup>2</sup> + 5x 2.5 mm <sup>2</sup> , 1x 15-pin female TYCO connector, 1x RJ45 connector, integrated shield fixing, can be used in cable drag chains	
	<b>Threaded caps</b>	
X67AC0M08	X67 M8 threaded caps, 50 pcs.	
X67AC0M12	X67 M12 threaded caps, 50 pcs.	

Table 6: 8CVI045E1HCS0.00-1 - Order data

### 4.1.2.3.2 Technical data

Order number	8CVI045E1HCS0.00-1	
<b>General information</b>		
Module type	ACOPOSremote module	
B&R ID code	0xC1B0	
Current-carrying capacity of 15-pin TYCO connector		
Power contacts	Max. 20 A at 40°C	
Cooling and mounting type	Cold plate mounting	
Certifications		
CE	Yes	
Functional safety <sup>1)</sup>	Yes	
UL	cULus E225616	
KC	Power conversion equipment	
	Yes	
<b>DC bus connection</b>		
Voltage		
Nominal	750 VDC	
Continuous power consumption <sup>2)</sup>	In preparation	
Power dissipation depending on switching frequency		
Switching frequency 5 kHz	$[0.16 * I_M^2 + 5.6 * I_M + 55 + (P_{out}/750)^2 * 0.25]$ W	
Switching frequency 10 kHz	$[0.49 * I_M^2 + 4.7 * I_M + 95 + (P_{out}/750)^2 * 0.25]$ W	
Switching frequency 20 kHz	$[0.87 * I_M^2 + 10 * I_M + 200 + (P_{out}/750)^2 * 0.25]$ W	
DC bus capacitance	35 µF	
Variant	15-pin male TYCO connector <sup>3)</sup>	
Line length		
Maximum	30 m	
<b>24 VDC power supply</b>		
Input voltage	24 VDC +20% / -25%	
Input capacitance	In preparation	
Max. power consumption	$10 \text{ W} + P_{24 \text{ V Out}} + P_{\text{Holding brake}} + P_{\text{Trigger}}^{4)}$	
Variant	15-pin male TYCO connector <sup>3)</sup>	
Line length		
Maximum	30 m	
<b>24 VDC output</b>		
Quantity	1	
Output voltage	Depends on the 24 VDC power supply	
Continuous current	Max. 8 A (max. 4 A per pin)	
Fuse protection	Electronic (per pin)	
Variant		
24 VDC, COM	M8 connector	
<b>Motor connection</b>		
Quantity	1	
Continuous power per motor connection <sup>2)</sup>	1.5 kW	
Continuous current per motor connection <sup>2)</sup>	4.5 A <sub>eff</sub>	
Reduction of continuous current depending on switching frequency <sup>5)</sup>		
Switching frequency 5 kHz	No reduction <sup>6)</sup>	
Switching frequency 10 kHz	No reduction	
Switching frequency 20 kHz	No reduction	

Table 7: 8CVI045E1HCS0.00-1 - Technical data

Order number	8CVI045E1HCS0.00-1
Reduction of continuous current depending on installation elevation	
Starting at 500 m above sea level	0.45 A per 1,000 m
Peak current	13.5 A <sub>eff</sub>
Nominal switching frequency	5 kHz
Possible switching frequencies <sup>7)</sup>	5 / 10 / 20 kHz
Insulation stress of the connected motor per IEC TS 60034-25:2004 <sup>8)</sup>	Limit value curve A
Protective measures	
Overload protection	Yes
Short-circuit and ground fault protection	Yes
Max. output frequency	598 Hz <sup>9)</sup>
Variant	
U, V, W, PE	8-pin speedtec connector, size 1
Shield connection	Yes (via connector housing)
Max. motor line length depending on switching frequency	
Switching frequency 5 kHz	10 m
Switching frequency 10 kHz	5 m
Switching frequency 20 kHz	5 m
<b>Motor holding brake connection</b>	
Quantity	1
Output voltage <sup>10)</sup>	24 VDC +5.8% / -0%
Continuous current per connection	1.1 A
Max. internal resistance	In preparation
Extinction potential	Approx. 30 V
Max. extinction energy per switching operation	1.5 Ws
Max. switching frequency	0.5 Hz
Protective measures	
Overload and short-circuit protection	Yes
Open-circuit monitoring	Yes
Undervoltage monitoring	Yes
Response threshold for open-circuit monitoring	Approx. 0.25 A
Response threshold for undervoltage monitoring	24 VDC +0% / -4%
<b>Fieldbus</b>	
Type	POWERLINK (V1/V2) 100BASE-T (ANSI/IEE 802.3)
Variant	Internal 3-port hub, 2x male 15-pin TYCO connector, 1x M12 connector
Line length	Max. 100 m between two stations (segment length) <sup>11)</sup>
Transfer rate	100 Mbit/s
<b>Encoder inputs</b>	
Quantity	1
Type	EnDat 2.1
Module-side connection	15-pin female springtec connector
Status indicators	UP/DN LEDs
Electrical isolation	
Encoder - ACOPOSremote	No
Encoder monitoring	Yes
Max. encoder cable length	10 m
Encoder power supply	
Output voltage	5 V ±5%
Load capacity	250 mA <sup>12)</sup>
Sense lines	2, compensation of max. 2x 0.7 V
Protective measures	
Overload-proof	Yes
Short-circuit proof	Yes
Sine/Cosine inputs	
Signal transmission	Differential signals, symmetrical
Signal frequency (-3 dB)	DC up to 300 kHz
Signal frequency (-5 dB)	DC up to 400 kHz
Differential voltage	0.5 to 1.25 V <sub>ss</sub>
Common-mode voltage	Max. ±7 V
Terminating resistor	120 Ω
Resolution	12-bit
Reference input	
Signal transmission	Differential signal, symmetrical
Differential voltage for low	≤ -0.2 V
Differential voltage for high	≥ 0.2 V
Common-mode voltage	Max. ±7 V
Terminating resistor	120 Ω
Position	
Resolution @ 1 V <sub>ss</sub> <sup>13)</sup>	Number of encoder lines * 5700
Accuracy <sup>14)</sup>	-
Noise <sup>14)</sup>	-

Table 7: 8CVI045E1HCS0.00-1 - Technical data

## Technical data

Order number	8CVI045E1HCS0.00-1
Synchronous serial interface	
Signal transmission	RS485
Data transfer rate	Depends on the configured functionality <sup>15)</sup>
<b>Enable inputs</b>	
Quantity	2
Circuit	Sink
Electrical isolation	
Input - Inverter module	Yes
Input - Input	Yes
Input voltage	
Nominal	24 VDC
Maximum	30 VDC
Input current at nominal voltage	Approx. 30 mA
Switching threshold	
Low	<5 V
High	>15 V
Switching delay at nominal input voltage	
Enable 1 → 0, PWM off	Max. 20.5 ms
Enable 0 → 1, ready for PWM	Max. 100 µs
Modulation compared to ground potential	Max. ±38 V
OSSD signal connections <sup>16)</sup>	Permitted Max. test pulse length: 500 µs
Variant	15-pin male TYCO connector <sup>3)</sup>
<b>Trigger inputs</b>	
Quantity	2
Circuit	Sink
Electrical isolation	
Input - Inverter module	No
Input - Input	No
Input voltage	
Nominal	24 VDC
Maximum	30 VDC
Switching threshold	
Low	<5 V
High	>15 V
Input current at nominal voltage	In preparation
Switching delay	
Rising edge	In preparation
Falling edge	In preparation
Modulation compared to ground potential	In preparation
Max. line length	30 m
Variant	M8 connector
<b>Temperature sensor connection</b>	
Quantity	1
Resistance range	500 Ω to 5 kΩ
<b>Support</b>	
Software	
ACP10	V2.35.1 and higher
<b>Electrical properties</b>	
Discharge capacitance	0.1 µF
<b>Operating conditions</b>	
Permissible mounting orientations	
Hanging vertically	Yes
Horizontal, face up	Yes
Standing horizontally	Yes
Installation elevation above sea level	
Nominal	0 to 500 m
Maximum <sup>17)</sup>	4000 m
Pollution degree per EN 61800-5-1	2 (non-conductive pollution)
Overvoltage category per EN 61800-5-1	III
Degree of protection per EN 60529 <sup>18)</sup>	IP65
<b>Ambient conditions</b>	
Temperature	
Operation	
Nominal	5 to 40°C <sup>19)</sup>
Maximum	60°C
Storage	-25 to 55°C
Transport	-25 to 70°C
Relative humidity	
Operation	5 to 85%, non-condensing
Storage	5 to 95%, non-condensing
Transport	Max. 95% at 40°C

Table 7: 8CVI045E1HCS0.00-1 - Technical data

Order number	8CVI045E1HCS0.00-1
<b>Mechanical properties</b>	
Dimensions <sup>20)</sup>	
Width	137 mm
Height	287.2 mm
Depth	131 mm
Weight	4.8 kg

Table 7: 8CVI045E1HCS0.00-1 - Technical data

- 1) Achievable safety classifications (safety integrity level, safety category, performance level) are documented in the user's manual (section "Safety technology").
- 2) Valid under the following conditions: 750 VDC DC bus voltage, 5 kHz switching frequency, 40°C ambient temperature, installation elevation <500 m above sea level, no derating due to cooling type.
- 3) It is important to note that the 15-pin male TYCO connector is designed for max. 20 mating cycles.
- 4) The power consumption  $P_{24V_{Out}}$  corresponds to the portion of the power that is output on the X31 connector on the module.
- 5) Valid under the following conditions: 750 VDC DC bus voltage. The temperature specifications refer to the ambient temperature.
- 6) Value for the nominal switching frequency.
- 7) B&R recommends operating the module at its nominal switching frequency. Operating the module at a higher switching frequency for application-specific reasons reduces the continuous current and increases CPU utilization.
- 8) If necessary, the stress of the motor isolation system can be reduced by an additional externally wired dv/dt choke. For example, the RWK 305 three-phase dv/dt choke from Schaffner ([www.schaffner.com](http://www.schaffner.com)) can be used. IMPORTANT: Even when using a dv/dt choke, it is necessary to ensure that an EMC-compatible, low inductance shield connection is used!
- 9) The module's electrical output frequency (SCTRL\_SPEED\_ACT \* MOTOR\_POLEPAIRS) is monitored to protect against dual use in accordance with Regulation (EC) 428/2009 | 3A225. If the electrical output frequency of the module exceeds the limit value of 598 Hz uninterrupted for more than 0.5 s, then the current movement is aborted and error 6060 is output ("Power unit: Limit speed exceeded").
- 10) During configuration, it is necessary to check if the minimum voltage can be maintained on the holding brake with the intended wiring. For the operating voltage range of the holding brake, see the user documentation for the motor being used.
- 11) Limited to 30 m when using hybrid cables.
- 12) An additional reserve of 57 mA is available for terminating resistors.
- 13) This value does not correspond to the encoder resolution that must be configured in Automation Studio (16384 \* number of encoder lines).
- 14) Limited by the encoder in practice.
- 15) EnDat 2.1 ... 781.25 kbit/s, SSI ... 100 to 400 kbit/s, BiSS ... 1560 kbit/s.
- 16) Output signal switching device (OSSD) signals are used for monitoring signal lines for short circuits and cross faults.
- 17) Continuous operation at an installation elevation of 500 m to 4,000 m above sea level is possible taking the specified reduction of continuous current into account. Requirements that go beyond this must be arranged with B&R.
- 18) The specified degree of protection is only met if all connectors on the module that are not being used are closed with suitable threaded caps or slot covers! Suitable threaded caps or slot covers are available as optional accessories (X67AC0M08, X67AC0M12, 8CXC000.0000-00). The module is delivered with IP20 protection.
- 19) The temperature of the module's mounting surface is not permitted to exceed 60°C.
- 20) The dimensions refer to the actual device dimensions. Additional spacing above and below the devices must be taken into account for mounting and connection.

### 4.1.2.4 8CVI045H1HCS0.00-1

#### 4.1.2.4.1 Order data

Order number	Short description	Figure
	<b>ACOPOSremote inverter units</b>	
8CVI045H1HCS0.00-1	ACOPOSremote ACOPOSmulti65 inverter module, 4.5 A, AS, IP65, 1x HIPERFACE encoder interface, cold plate mounting	
	<b>Optional accessories</b>	
	<b>1.5 mm² motor cables</b>	
8CCM0003.11110-0	ACOPOSremote motor cable, length 3 m, 4x 1.5 mm² + 2x 2x 0.75 mm², 8-pin female speedtec motor connector size 1, 8-pin male speedtec servo connector size 1, can be used in cable drag chains	
8CCM0005.11110-0	ACOPOSremote motor cable, length 5 m, 4x 1.5 mm² + 2x 2x 0.75 mm², 8-pin female speedtec motor connector size 1, 8-pin male speedtec servo connector size 1, can be used in cable drag chains	
8CCM0010.11110-0	ACOPOSremote motor cable, length 10 m, 4x 1.5 mm² + 2x 2x 0.75 mm², 8-pin female speedtec motor connector size 1, 8-pin male speedtec servo connector size 1, can be used in cable drag chains	
8CCM0015.11110-0	ACOPOSremote motor cable, length 15 m, 4x 1.5 mm² + 2x 2x 0.75 mm², 8-pin female speedtec motor connector size 1, 8-pin male speedtec servo connector size 1, can be used in cable drag chains	
	<b>8BVE / 8CVI connection cables</b>	
8CCH0005.11120-1	Hybrid cable for connecting 8BVE to 8CVI or 8DI, length 5 m, 2x 2x 0.34 mm² + 4x 0.75 mm² + 5x 2.5 mm², 1x 15-pin female TYCO connector, 1x RJ45 connector, integrated shield fixing, can be used in cable drag chains	
8CCH0007.11120-1	Hybrid cable for connecting 8BVE to 8CVI or 8DI, length 7 m, 2x 2x 0.34 mm² + 4x 0.75 mm² + 5x 2.5 mm², 1x 15-pin female TYCO connector, 1x RJ45 connector, integrated shield fixing, can be used in cable drag chains	
8CCH0010.11120-1	Hybrid cable for connecting 8BVE to 8CVI or 8DI, length 10 m, 2x 2x 0.34 mm² + 4x 0.75 mm² + 5x 2.5 mm², 1x 15-pin female TYCO connector, 1x RJ45 connector, integrated shield fixing, can be used in cable drag chains	
	<b>Accessory sets</b>	
8CXC000.0000-00	Accessory set: 1x slot cover for hybrid connector	
8CXM000.0000-00	ACOPOSremote accessory set: 4x hex socket screw M6x80mm for 8CVI inverter modules	
	<b>Hybrid cables</b>	
8CCH0003.11110-1	Hybrid cable, length 3 m, 2x 2x 0.34 mm² + 4x 0.75 mm² + 5x 2.5 mm², 2x 15-pin female TYCO connector, can be used in cable drag chains	
8CCH0003.11130-1	Hybrid cable, length 3 m, 2x 2x 0.34 mm² + 4x 0.75 mm² + 5x 2.5 mm², 2x 15-pin female TYCO connector, 1x connector insert rotated 180°, can be used in cable drag chains	
8CCH0005.11110-1	Hybrid cable, length 5 m, 2x 2x 0.34 mm² + 4x 0.75 mm² + 5x 2.5 mm², 2x 15-pin female TYCO connector, can be used in cable drag chains	
8CCH0010.11110-1	Hybrid cable, length 10 m, 2x 2x 0.34 mm² + 4x 0.75 mm² + 5x 2.5 mm², 2x 15-pin female TYCO connector, can be used in cable drag chains	
8CCH0015.11110-1	Hybrid cable, length 15 m, 2x 2x 0.34 mm² + 4x 0.75 mm² + 5x 2.5 mm², 2x 15-pin female TYCO connector, can be used in cable drag chains	
8CCH0020.11110-1	Hybrid cable, length 20 m, 2x 2x 0.34 mm² + 4x 0.75 mm² + 5x 2.5 mm², 2x 15-pin female TYCO connector, can be used in cable drag chains	
	<b>One-sided hybrid cables</b>	
8CCH0005.11150-1	Hybrid cable for connecting 8EI to 8CVI or 8DI, length 5 m, 2x 2x 0.34 mm² + 4x 0.75 mm² + 5x 2.5 mm², 1x 15-pin female TYCO connector, 1x RJ45 connector, integrated shield fixing, can be used in cable drag chains	
8CCH0007.11150-1	Hybrid cable for connecting 8EI to 8CVI or 8DI, length 7 m, 2x 2x 0.34 mm² + 4x 0.75 mm² + 5x 2.5 mm², 1x 15-pin female TYCO connector, 1x RJ45 connector, integrated shield fixing, can be used in cable drag chains	
8CCH0010.11150-1	Hybrid cable for connecting 8EI to 8CVI or 8DI, length 10 m, 2x 2x 0.34 mm² + 4x 0.75 mm² + 5x 2.5 mm², 1x 15-pin female TYCO connector, 1x RJ45 connector, integrated shield fixing, can be used in cable drag chains	
8CCH0015.11150-1	Hybrid cable for connecting 8EI to 8CVI or 8DI, length 15 m, 2x 2x 0.34 mm² + 4x 0.75 mm² + 5x 2.5 mm², 1x 15-pin female TYCO connector, 1x RJ45 connector, integrated shield fixing, can be used in cable drag chains	

Table 8: 8CVI045H1HCS0.00-1 - Order data

Order number	Short description	Figure
8CCH0020.11150-1	Hybrid cable for connecting 8EI to 8CVI or 8DI, length 20 m, 2x 2x 0.34 mm <sup>2</sup> + 4x 0.75 mm <sup>2</sup> + 5x 2.5 mm <sup>2</sup> , 1x 15-pin female TYCO connector, 1x RJ45 connector, integrated shield fixing, can be used in cable drag chains	
8CCH0025.11150-1	Hybrid cable for connecting 8EI to 8CVI or 8DI, length 25 m, 2x 2x 0.34 mm <sup>2</sup> + 4x 0.75 mm <sup>2</sup> + 5x 2.5 mm <sup>2</sup> , 1x 15-pin female TYCO connector, 1x RJ45 connector, integrated shield fixing, can be used in cable drag chains	
<b>Threaded caps</b>		
X67AC0M08	X67 M8 threaded caps, 50 pcs.	
X67AC0M12	X67 M12 threaded caps, 50 pcs.	

Table 8: 8CVI045H1HCS0.00-1 - Order data

#### 4.1.2.4.2 Technical data

Order number	8CVI045H1HCS0.00-1
<b>General information</b>	
Module type	ACOPOSremote module
B&R ID code	0xC1B1
Current-carrying capacity of 15-pin TYCO connector	
Power contacts	Max. 20 A at 40°C
Cooling and mounting type	Cold plate mounting
Certifications	
CE	Yes
Functional safety <sup>1)</sup>	Yes
UL	cULus E225616 Power conversion equipment
<b>DC bus connection</b>	
Voltage	
Nominal	750 VDC
Continuous power consumption <sup>2)</sup>	In preparation
Power dissipation depending on switching frequency	
Switching frequency 5 kHz	$[0.16 * I_M^2 + 5.6 * I_M + 55 + (P_{out}/750)^2 * 0.25]$ W
Switching frequency 10 kHz	$[0.49 * I_M^2 + 4.7 * I_M + 95 + (P_{out}/750)^2 * 0.25]$ W
Switching frequency 20 kHz	$[0.87 * I_M^2 + 10 * I_M + 200 + (P_{out}/750)^2 * 0.25]$ W
DC bus capacitance	35 µF
Variant	15-pin male TYCO connector <sup>3)</sup>
Line length	
Maximum	30 m
<b>24 VDC power supply</b>	
Input voltage	24 VDC +20% / -25%
Input capacitance	In preparation
Max. power consumption	$10 \text{ W} + P_{24 \text{ V out}} + P_{\text{Holding brake}} + P_{\text{Trigger}}^{4)}$
Variant	15-pin male TYCO connector <sup>3)</sup>
Line length	
Maximum	30 m
<b>24 VDC output</b>	
Quantity	1
Output voltage	Depends on the 24 VDC power supply
Continuous current	Max. 8 A (max. 4 A per pin)
Fuse protection	Electronic (per pin)
Variant	
24 VDC, COM	M8 connector
<b>Motor connection</b>	
Quantity	1
Continuous power per motor connection <sup>2)</sup>	1.5 kW
Continuous current per motor connection <sup>2)</sup>	4.5 A <sub>eff</sub>
Reduction of continuous current depending on switching frequency <sup>5)</sup>	
Switching frequency 5 kHz	No reduction <sup>6)</sup>
Switching frequency 10 kHz	No reduction
Switching frequency 20 kHz	No reduction
Reduction of continuous current depending on installation elevation	
Starting at 500 m above sea level	0.45 A per 1,000 m
Peak current	13.5 A <sub>eff</sub>
Nominal switching frequency	5 kHz
Possible switching frequencies <sup>7)</sup>	5 / 10 / 20 kHz
Insulation stress of the connected motor per IEC TS 60034-25:2004 <sup>8)</sup>	Limit value curve A

Table 9: 8CVI045H1HCS0.00-1 - Technical data

## Technical data

Order number	8CVI045H1HCS0.00-1
Protective measures	
Overload protection	Yes
Short-circuit and ground fault protection	Yes
Max. output frequency	598 Hz <sup>9)</sup>
Variant	
U, V, W, PE	8-pin speedtec connector, size 1
Shield connection	Yes (via connector housing)
Max. motor line length depending on switching frequency	
Switching frequency 5 kHz	10 m
Switching frequency 10 kHz	5 m
Switching frequency 20 kHz	5 m
<b>Motor holding brake connection</b>	
Quantity	1
Output voltage <sup>10)</sup>	24 VDC +5.8% / -0%
Continuous current per connection	1.1 A
Max. internal resistance	In preparation
Extinction potential	Approx. 30 V
Max. extinction energy per switching operation	1.5 Ws
Max. switching frequency	0.5 Hz
Protective measures	
Overload and short-circuit protection	Yes
Open-circuit monitoring	Yes
Undervoltage monitoring	Yes
Response threshold for open-circuit monitoring	Approx. 0.25 A
Response threshold for undervoltage monitoring	24 VDC +0% / -4%
<b>Fieldbus</b>	
Type	POWERLINK (V1/V2) 100BASE-T (ANSI/IEE 802.3)
Variant	Internal 3-port hub, 2x male 15-pin TYCO connector, 1x M12 connector
Line length	Max. 100 m between two stations (segment length) <sup>11)</sup>
Transfer rate	100 Mbit/s
<b>Encoder inputs</b>	
Quantity	1
Type	HIPERFACE
Module-side connection	15-pin female springtec connector
Status indicators	UP/DN LEDs
Electrical isolation	
Encoder - ACOPOSremote	No
Encoder monitoring	Yes
Max. encoder cable length	10 m
Encoder power supply	
Output voltage	Typ. 10 V
Load capacity	130 mA <sup>12)</sup>
Sense lines	-
Protective measures	
Overload-proof	Yes
Short-circuit proof	Yes
Sine/Cosine inputs	
Signal transmission	Differential signal, asymmetrical
Signal frequency	DC up to 200 kHz
Differential voltage	0.5 to 1.25 V <sub>SS</sub>
Common-mode voltage	Max. ±7 V
Terminating resistor	120 Ω
Resolution	12-bit
Position	
Resolution @ 1 V <sub>SS</sub> <sup>13)</sup>	Number of encoder lines * 5700
Accuracy <sup>14)</sup>	-
Noise <sup>14)</sup>	-
Asynchronous serial interface	
Signal transmission	RS485
Data transfer rate	9600 bit/s
<b>Enable inputs</b>	
Quantity	2
Circuit	Sink
Electrical isolation	
Input - Inverter module	Yes
Input - Input	Yes
Input voltage	
Nominal	24 VDC
Maximum	30 VDC
Input current at nominal voltage	Approx. 30 mA

Table 9: 8CVI045H1HCS0.00-1 - Technical data

Order number	8CVI045H1HCS0.00-1
Switching threshold	
Low	<5 V
High	>15 V
Switching delay at nominal input voltage	
Enable 1 → 0, PWM off	Max. 20.5 ms
Enable 0 → 1, ready for PWM	Max. 100 µs
Modulation compared to ground potential	Max. ±38 V
OSSD signal connections <sup>15)</sup>	Permitted Max. test pulse length: 500 µs
Variant	15-pin male TYCO connector <sup>3)</sup>
<b>Trigger inputs</b>	
Quantity	2
Circuit	Sink
Electrical isolation	
Input - Inverter module	No
Input - Input	No
Input voltage	
Nominal	24 VDC
Maximum	30 VDC
Switching threshold	
Low	<5 V
High	>15 V
Input current at nominal voltage	In preparation
Switching delay	
Rising edge	In preparation
Falling edge	In preparation
Modulation compared to ground potential	In preparation
Max. line length	30 m
Variant	M8 connector
Sensor/Actuator power supply	
Voltage	24 VDC
Summation current	Max. 250 mA <sup>16)</sup>
<b>Temperature sensor connection</b>	
Quantity	1
Resistance range	500 Ω to 5 kΩ
<b>Support</b>	
Software	
ACP10	V2.28.0 and higher
<b>Electrical properties</b>	
Discharge capacitance	0.1 µF
<b>Operating conditions</b>	
Permissible mounting orientations	
Hanging vertically	Yes
Horizontal, face up	Yes
Standing horizontally	Yes
Installation elevation above sea level	
Nominal	0 to 500 m
Maximum <sup>17)</sup>	4000 m
Pollution degree per EN 61800-5-1	2 (non-conductive pollution)
Overvoltage category per EN 61800-5-1	III
Degree of protection per EN 60529	IP65 <sup>18)</sup>
<b>Ambient conditions</b>	
Temperature	
Operation	
Nominal	5 to 40°C <sup>19)</sup>
Maximum	60°C
Storage	-25 to 55°C
Transport	-25 to 70°C
Relative humidity	
Operation	5 to 85%, non-condensing
Storage	5 to 95%, non-condensing
Transport	Max. 95% at 40°C
<b>Mechanical properties</b>	
Dimensions <sup>20)</sup>	
Width	137 mm
Height	287.2 mm
Depth	131 mm
Weight	4.8 kg

Table 9: 8CVI045H1HCS0.00-1 - Technical data

- 1) Achievable safety classifications (safety integrity level, safety category, performance level) are documented in the user's manual (section "Safety technology").
- 2) Valid under the following conditions: 750 VDC DC bus voltage, 5 kHz switching frequency, 40°C ambient temperature, installation elevation <500 m above sea level, no derating due to cooling type.
- 3) It is important to note that the 15-pin male TYCO connector is designed for max. 20 mating cycles.

## Technical data

- 4) The power consumption  $P_{24V Out}$  corresponds to the portion of the power that is output on the X31 connector on the module.
- 5) Valid under the following conditions: 750 VDC DC bus voltage. The temperature specifications refer to the ambient temperature.
- 6) Value for the nominal switching frequency.
- 7) B&R recommends operating the module at its nominal switching frequency. Operating the module at a higher switching frequency for application-specific reasons reduces the continuous current and increases CPU utilization.
- 8) If necessary, the stress of the motor isolation system can be reduced by an additional externally wired dv/dt choke. For example, the RWK 305 three-phase dv/dt choke from Schaffner ([www.schaffner.com](http://www.schaffner.com)) can be used. IMPORTANT: Even when using a dv/dt choke, it is necessary to ensure that an EMC-compatible, low inductance shield connection is used!
- 9) The module's electrical output frequency (SCTRL\_SPEED\_ACT \* MOTOR\_POLEPAIRS) is monitored to protect against dual use in accordance with Regulation (EC) 428/2009 | 3A225. If the electrical output frequency of the module exceeds the limit value of 598 Hz uninterrupted for more than 0.5 s, then the current movement is aborted and error 6060 is output ("Power unit: Limit speed exceeded").
- 10) During configuration, it is necessary to check if the minimum voltage can be maintained on the holding brake with the intended wiring. For the operating voltage range of the holding brake, see the user documentation for the motor being used.
- 11) Limited to 30 m when using hybrid cables.
- 12) An additional reserve of 40 mA is available for terminating resistors.
- 13) This value does not correspond to the encoder resolution that must be configured in Automation Studio (16384 \* number of encoder lines).
- 14) Limited by the encoder in practice.
- 15) Output signal switching device (OSSD) signals are used for monitoring signal lines for short circuits and cross faults.
- 16) The summation current corresponds to the current that is output on the X23A and X24A connectors on the module.
- 17) Continuous operation at an installation elevation of 500 m to 4,000 m above sea level is possible taking the specified reduction of continuous current into account. Requirements that go beyond this must be arranged with B&R.
- 18) The specified degree of protection is only met if all connectors on the module that are not being used are closed with suitable threaded caps or slot covers! Suitable threaded caps or slot covers are available as optional accessories (X67AC0M08, X67AC0M12, 8CXC000.0000-00). The module is delivered with IP20 protection.
- 19) The temperature of the module's mounting surface is not permitted to exceed 60°C.
- 20) The dimensions refer to the actual device dimensions. Additional spacing above and below the devices must be taken into account for mounting and connection.

### 4.1.2.5 8CVI088S1HCS0.00-1

#### 4.1.2.5.1 Order data

Order number	Short description	Figure
	<b>ACOPOSremote inverter units</b>	
8CVI088S1HCS0.00-1	ACOPOSremote ACOPOSmulti65 inverter module, 8.8 A, AS, IP65, 1x SinCos encoder interface, cold plate mounting	
	<b>Optional accessories</b>	
	<b>1.5 mm² motor cables</b>	
8CCM0003.11110-0	ACOPOSremote motor cable, length 3 m, 4x 1.5 mm² + 2x 2x 0.75 mm², 8-pin female speedtec motor connector size 1, 8-pin male speedtec servo connector size 1, can be used in cable drag chains	
8CCM0005.11110-0	ACOPOSremote motor cable, length 5 m, 4x 1.5 mm² + 2x 2x 0.75 mm², 8-pin female speedtec motor connector size 1, 8-pin male speedtec servo connector size 1, can be used in cable drag chains	
8CCM0010.11110-0	ACOPOSremote motor cable, length 10 m, 4x 1.5 mm² + 2x 2x 0.75 mm², 8-pin female speedtec motor connector size 1, 8-pin male speedtec servo connector size 1, can be used in cable drag chains	
8CCM0015.11110-0	ACOPOSremote motor cable, length 15 m, 4x 1.5 mm² + 2x 2x 0.75 mm², 8-pin female speedtec motor connector size 1, 8-pin male speedtec servo connector size 1, can be used in cable drag chains	
	<b>8BVE / 8CVI connection cables</b>	
8CCH0005.11120-1	Hybrid cable for connecting 8BVE to 8CVI or 8DI, length 5 m, 2x 2x 0.34 mm² + 4x 0.75 mm² + 5x 2.5 mm², 1x 15-pin female TYCO connector, 1x RJ45 connector, integrated shield fixing, can be used in cable drag chains	
8CCH0007.11120-1	Hybrid cable for connecting 8BVE to 8CVI or 8DI, length 7 m, 2x 2x 0.34 mm² + 4x 0.75 mm² + 5x 2.5 mm², 1x 15-pin female TYCO connector, 1x RJ45 connector, integrated shield fixing, can be used in cable drag chains	
8CCH0010.11120-1	Hybrid cable for connecting 8BVE to 8CVI or 8DI, length 10 m, 2x 2x 0.34 mm² + 4x 0.75 mm² + 5x 2.5 mm², 1x 15-pin female TYCO connector, 1x RJ45 connector, integrated shield fixing, can be used in cable drag chains	
	<b>Accessory sets</b>	
8CXC000.0000-00	Accessory set: 1x slot cover for hybrid connector	
8CXM000.0000-00	ACOPOSremote accessory set: 4x hex socket screw M6x80mm for 8CVI inverter modules	
	<b>Hybrid cables</b>	
8CCH0003.11110-1	Hybrid cable, length 3 m, 2x 2x 0.34 mm² + 4x 0.75 mm² + 5x 2.5 mm², 2x 15-pin female TYCO connector, can be used in cable drag chains	
8CCH0003.11130-1	Hybrid cable, length 3 m, 2x 2x 0.34 mm² + 4x 0.75 mm² + 5x 2.5 mm², 2x 15-pin female TYCO connector, 1x connector insert rotated 180°, can be used in cable drag chains	
8CCH0005.11110-1	Hybrid cable, length 5 m, 2x 2x 0.34 mm² + 4x 0.75 mm² + 5x 2.5 mm², 2x 15-pin female TYCO connector, can be used in cable drag chains	
8CCH0010.11110-1	Hybrid cable, length 10 m, 2x 2x 0.34 mm² + 4x 0.75 mm² + 5x 2.5 mm², 2x 15-pin female TYCO connector, can be used in cable drag chains	
8CCH0015.11110-1	Hybrid cable, length 15 m, 2x 2x 0.34 mm² + 4x 0.75 mm² + 5x 2.5 mm², 2x 15-pin female TYCO connector, can be used in cable drag chains	
8CCH0020.11110-1	Hybrid cable, length 20 m, 2x 2x 0.34 mm² + 4x 0.75 mm² + 5x 2.5 mm², 2x 15-pin female TYCO connector, can be used in cable drag chains	
	<b>One-sided hybrid cables</b>	
8CCH0005.11150-1	Hybrid cable for connecting 8EI to 8CVI or 8DI, length 5 m, 2x 2x 0.34 mm² + 4x 0.75 mm² + 5x 2.5 mm², 1x 15-pin female TYCO connector, 1x RJ45 connector, integrated shield fixing, can be used in cable drag chains	
8CCH0007.11150-1	Hybrid cable for connecting 8EI to 8CVI or 8DI, length 7 m, 2x 2x 0.34 mm² + 4x 0.75 mm² + 5x 2.5 mm², 1x 15-pin female TYCO connector, 1x RJ45 connector, integrated shield fixing, can be used in cable drag chains	
8CCH0010.11150-1	Hybrid cable for connecting 8EI to 8CVI or 8DI, length 10 m, 2x 2x 0.34 mm² + 4x 0.75 mm² + 5x 2.5 mm², 1x 15-pin female TYCO connector, 1x RJ45 connector, integrated shield fixing, can be used in cable drag chains	
8CCH0015.11150-1	Hybrid cable for connecting 8EI to 8CVI or 8DI, length 15 m, 2x 2x 0.34 mm² + 4x 0.75 mm² + 5x 2.5 mm², 1x 15-pin female TYCO connector, 1x RJ45 connector, integrated shield fixing, can be used in cable drag chains	

Table 10: 8CVI088S1HCS0.00-1 - Order data

## Technical data

Order number	Short description	Figure
8CCH0020.11150-1	Hybrid cable for connecting 8EI to 8CVI or 8DI, length 20 m, 2x 2x 0.34 mm <sup>2</sup> + 4x 0.75 mm <sup>2</sup> + 5x 2.5 mm <sup>2</sup> , 1x 15-pin female TYCO connector, 1x RJ45 connector, integrated shield fixing, can be used in cable drag chains	
8CCH0025.11150-1	Hybrid cable for connecting 8EI to 8CVI or 8DI, length 25 m, 2x 2x 0.34 mm <sup>2</sup> + 4x 0.75 mm <sup>2</sup> + 5x 2.5 mm <sup>2</sup> , 1x 15-pin female TYCO connector, 1x RJ45 connector, integrated shield fixing, can be used in cable drag chains	
	<b>SinCos cables</b>	
8CCS0003.11110-0	ACOPOSremote EnDat 2.1 cable, length 3 m, 10x 0.14 mm <sup>2</sup> + 2x 0.5 mm <sup>2</sup> , 12-pin female series 615 signal connector, 15-pin male series 615 signal connector, can be used in cable drag chains	
8CCS0005.11110-0	ACOPOSremote EnDat 2.1 cable, length 5 m, 10x 0.14 mm <sup>2</sup> + 2x 0.5 mm <sup>2</sup> , 12-pin female series 615 signal connector, 15-pin male series 615 signal connector, can be used in cable drag chains	
8CCS0010.11110-0	ACOPOSremote EnDat 2.1 cable, length 10 m, 10x 0.14 mm <sup>2</sup> + 2x 0.5 mm <sup>2</sup> , 12-pin female series 615 signal connector, 15-pin male series 615 signal connector, can be used in cable drag chains	
8CCS0015.11110-0	ACOPOSremote EnDat 2.1 cable, length 15 m, 10x 0.14 mm <sup>2</sup> + 2x 0.5 mm <sup>2</sup> , 12-pin female series 615 signal connector, 15-pin male series 615 signal connector, can be used in cable drag chains	
	<b>Threaded caps</b>	
X67AC0M08	X67 M8 threaded caps, 50 pcs.	
X67AC0M12	X67 M12 threaded caps, 50 pcs.	

Table 10: 8CVI088S1HCS0.00-1 - Order data

### 4.1.2.5.2 Technical data

Order number	8CVI088S1HCS0.00-1
<b>General information</b>	
Module type	ACOPOSremote module
B&R ID code	0xDDA6
Current-carrying capacity of 15-pin TYCO connector	
Power contacts	Max. 20 A at 40°C
Support	
Dynamic node allocation (DNA)	Yes
Cooling and mounting type	Cold plate mounting
Certifications	
CE	Yes
Functional safety <sup>1)</sup>	Yes
UL	cULus E225616 Power conversion equipment
<b>DC bus connection</b>	
Voltage	
Nominal	750 VDC
Continuous power consumption <sup>2)</sup>	In preparation
Power dissipation depending on switching frequency	
Switching frequency 5 kHz	$[0.16 * I_M^2 + 5.6 * I_M + 55 + (P_{out}/750)^2 * 0.25]$ W
Switching frequency 10 kHz	$[0.49 * I_M^2 + 4.7 * I_M + 95 + (P_{out}/750)^2 * 0.25]$ W
Switching frequency 20 kHz	$[0.87 * I_M^2 + 10 * I_M + 200 + (P_{out}/750)^2 * 0.25]$ W
DC bus capacitance	35 µF
Variant	15-pin male TYCO connector <sup>3)</sup>
Line length	
Maximum	30 m
<b>24 VDC power supply</b>	
Input voltage	24 VDC +20% / -25%
Input capacitance	In preparation
Max. power consumption	$10 \text{ W} + P_{24 \text{ V out}} + P_{\text{Holding brake}} + P_{\text{Trigger}}^4)$
Variant	15-pin male TYCO connector <sup>3)</sup>
Line length	
Maximum	30 m
<b>24 VDC output</b>	
Quantity	1
Output voltage	Depends on the 24 VDC power supply
Continuous current	Max. 8 A (max. 4 A per pin)
Fuse protection	Electronic (per pin)
Variant	
24 VDC, COM	M8 connector
<b>Motor connection</b>	
Quantity	1

Table 11: 8CVI088S1HCS0.00-1 - Technical data

Order number	8CVI088S1HCS0.00-1
Continuous power per motor connection <sup>2)</sup>	4 kW
Continuous current per motor connection <sup>2)</sup>	8.8 A <sub>eff</sub>
Reduction of continuous current depending on switching frequency <sup>5)</sup>	
Switching frequency 5 kHz	No reduction <sup>6)</sup>
Switching frequency 10 kHz	No reduction
Switching frequency 20 kHz	No reduction
Reduction of continuous current depending on installation elevation	
Starting at 500 m above sea level	0.88 A per 1,000 m
Peak current	24.5 A <sub>eff</sub>
Nominal switching frequency	5 kHz
Possible switching frequencies <sup>7)</sup>	5 / 10 / 20 kHz
Insulation stress of the connected motor per IEC TS 60034-25:2004 <sup>8)</sup>	Limit value curve A
Protective measures	
Overload protection	Yes
Short-circuit and ground fault protection	Yes
Max. output frequency	598 Hz <sup>9)</sup>
Variant	
U, V, W, PE	8-pin speedtec connector, size 1
Shield connection	Yes (via connector housing)
Max. motor line length depending on switching frequency	
Switching frequency 5 kHz	10 m
Switching frequency 10 kHz	5 m
Switching frequency 20 kHz	5 m
<b>Motor holding brake connection</b>	
Quantity	1
Output voltage <sup>10)</sup>	24 VDC +5.8% / -0%
Continuous current per connection	1.1 A
Max. internal resistance	In preparation
Extinction potential	Approx. 30 V
Max. extinction energy per switching operation	1.5 Ws
Max. switching frequency	0.5 Hz
Protective measures	
Overload and short-circuit protection	Yes
Open-circuit monitoring	Yes
Undervoltage monitoring	Yes
Response threshold for open-circuit monitoring	Approx. 0.25 A
Response threshold for undervoltage monitoring	24 VDC +0% / -4%
<b>Fieldbus</b>	
Type	POWERLINK (V1/V2) 100BASE-T (ANSI/IEE 802.3)
Variant	Internal 3-port hub, 2x male 15-pin TYCO connector, 1x M12 connector
Line length	Max. 100 m between two stations (segment length) <sup>11)</sup>
Transfer rate	100 Mbit/s
<b>Encoder inputs</b>	
Quantity	1
Type	SinCos
Module-side connection	15-pin female springtec connector
Status indicators	UP/DN LEDs
Electrical isolation	
Encoder - ACOPOSremote	No
Encoder monitoring	Yes
Max. encoder cable length	10 m
Encoder power supply	
Output voltage	5 V ±5%
Load capacity	300 mA <sup>12)</sup>
Sense lines	2, compensation of max. 2 x 0.7 V
Protective measures	
Overload-proof	Yes
Short-circuit proof	Yes
Sine/Cosine inputs	
Signal transmission	Differential signals, symmetrical
Signal frequency (-3 dB)	DC up to 300 kHz
Signal frequency (-5 dB)	DC up to 400 kHz
Differential voltage	0.5 to 1.25 V <sub>ss</sub>
Common-mode voltage	Max. ±7 V
Terminating resistor	120 Ω
ADC resolution	12-bit

Table 11: 8CVI088S1HCS0.00-1 - Technical data

## Technical data

Order number	8CVI088S1HCS0.00-1
Reference input	
Signal transmission	Differential signal, symmetrical
Differential voltage for low	$\leq -0.2$ V
Differential voltage for high	$\geq 0.2$ V
Common-mode voltage	Max. $\pm 7$ V
Terminating resistor	120 $\Omega$
Position	
Resolution @ 1 V <sub>SS</sub> <sup>13)</sup>	Number of encoder lines * 5700
Accuracy <sup>14)</sup>	-
Noise <sup>14)</sup>	-
Limit switch inputs <sup>15)</sup>	
Quantity	2
Circuit	Source
Input resistance	1470 $\Omega$
Electrical isolation	
Input - ACOPOSremote	No
Input - Input	No
Input voltage	
Minimum	-12 V
Nominal	5 V
Maximum	20 V
Switching threshold	
Low	<0.8 V
High	>2 V
Switching delay	Max. 100 $\mu$ s
<b>Enable inputs</b>	
Quantity	2
Circuit	Sink
Electrical isolation	
Input - Inverter module	Yes
Input - Input	Yes
Input voltage	
Nominal	24 VDC
Maximum	30 VDC
Input current at nominal voltage	Approx. 30 mA
Switching threshold	
Low	<5 V
High	>15 V
Switching delay at nominal input voltage	
Enable 1 $\rightarrow$ 0, PWM off	Max. 20.5 ms
Enable 0 $\rightarrow$ 1, ready for PWM	Max. 100 $\mu$ s
Modulation compared to ground potential	Max. $\pm 38$ V
OSSD signal connections <sup>16)</sup>	Permitted Max. test pulse length: 500 $\mu$ s
Variant	15-pin male TYCO connector <sup>3)</sup>
<b>Trigger inputs</b>	
Quantity	2
Circuit	Sink
Electrical isolation	
Input - Inverter module	No
Input - Input	No
Input voltage	
Nominal	24 VDC
Maximum	30 VDC
Switching threshold	
Low	<5 V
High	>15 V
Input current at nominal voltage	In preparation
Switching delay	
Rising edge	In preparation
Falling edge	In preparation
Modulation compared to ground potential	In preparation
Max. line length	30 m
Variant	M8 connector
Sensor/Actuator power supply	
Voltage	24 VDC
Summation current	Max. 250 mA <sup>17)</sup>
<b>Temperature sensor connection</b>	
Quantity	1
Resistance range	500 $\Omega$ to 5 k $\Omega$
<b>Support</b>	
Software	
ACP10	V2.35.1 and higher

Table 11: 8CVI088S1HCS0.00-1 - Technical data

<b>Order number</b>	<b>8CVI088S1HCS0.00-1</b>
<b>Electrical properties</b>	
Discharge capacitance	0.1 µF
<b>Operating conditions</b>	
Permissible mounting orientations	
Hanging vertically	Yes
Horizontal, face up	Yes
Standing horizontally	Yes
Installation elevation above sea level	
Nominal	0 to 500 m
Maximum <sup>18)</sup>	4000 m
Pollution degree per EN 61800-5-1	2 (non-conductive pollution)
Overvoltage category per EN 61800-5-1	III
Degree of protection per EN 60529	IP65 <sup>19)</sup>
<b>Ambient conditions</b>	
Temperature	
Operation	
Nominal	5 to 40°C <sup>20)</sup>
Maximum	60°C
Storage	-25 to 55°C
Transport	-25 to 70°C
Relative humidity	
Operation	5 to 85%, non-condensing
Storage	5 to 95%, non-condensing
Transport	Max. 95% at 40°C
<b>Mechanical properties</b>	
Dimensions <sup>21)</sup>	
Width	137 mm
Height	287.2 mm
Depth	131 mm
Weight	4.8 kg

Table 11: 8CVI088S1HCS0.00-1 - Technical data

- 1) Achievable safety classifications (safety integrity level, safety category, performance level) are documented in the user's manual (section "Safety technology").
- 2) Valid under the following conditions: 750 VDC DC bus voltage, 5 kHz switching frequency, 40°C ambient temperature, installation elevation <500 m above sea level, no derating due to cooling type.
- 3) It is important to note that the 15-pin male TYCO connector is designed for max. 20 mating cycles.
- 4) The power consumption  $P_{24V\ Out}$  corresponds to the portion of the power that is output on the X31 connector on the module.
- 5) Valid under the following conditions: 750 VDC DC bus voltage. The temperature specifications refer to the ambient temperature.
- 6) Value for the nominal switching frequency.
- 7) B&R recommends operating the module at its nominal switching frequency. Operating the module at a higher switching frequency for application-specific reasons reduces the continuous current and increases CPU utilization.
- 8) If necessary, the stress of the motor isolation system can be reduced by an additional externally wired dv/dt choke. For example, the RWK 305 three-phase dv/dt choke from Schaffner ([www.schaffner.com](http://www.schaffner.com)) can be used. IMPORTANT: Even when using a dv/dt choke, it is necessary to ensure that an EMC-compatible, low inductance shield connection is used!
- 9) The module's electrical output frequency (SCTRL\_SPEED\_ACT \* MOTOR\_POLEPAIRS) is monitored to protect against dual use in accordance with Regulation (EC) 428/2009 | 3A225. If the electrical output frequency of the module exceeds the limit value of 598 Hz uninterrupted for more than 0.5 s, then the current movement is aborted and error 6060 is output ("Power unit: Limit speed exceeded").
- 10) During configuration, it is necessary to check if the minimum voltage can be maintained on the holding brake with the intended wiring. For the operating voltage range of the holding brake, see the user documentation for the motor being used.
- 11) Limited to 30 m when using hybrid cables.
- 12) An additional reserve of 12 mA exists for terminating resistors and limit switch inputs.
- 13) This value does not correspond to the encoder resolution that must be configured in Automation Studio (16384 \* number of encoder lines).
- 14) Limited by the encoder in practice.
- 15) The measurement system offered by Heidenhain with limit switch outputs LIDA 47x, LIDA 48x and LIF4x1 was tested for compatibility. In practice, the cable length is limited by the encoder.
- 16) Output signal switching device (OSSD) signals are used for monitoring signal lines for short circuits and cross faults.
- 17) The summation current corresponds to the current that is output on the X23A and X24A connectors on the module.
- 18) Continuous operation at an installation elevation of 500 m to 4,000 m above sea level is possible taking the specified reduction of continuous current into account. Requirements that go beyond this must be arranged with B&R.
- 19) The specified degree of protection is only met if all connectors on the module that are not being used are closed with suitable threaded caps or slot covers! Suitable threaded caps or slot covers are available as optional accessories (X67AC0M08, X67AC0M12, 8CXC000.0000-00). The module is delivered with IP20 protection.
- 20) The temperature of the module's mounting surface is not permitted to exceed 60°C.
- 21) The dimensions refer to the actual device dimensions. Additional spacing above and below the devices must be taken into account for mounting and connection.

### 4.1.2.6 8CVI088E1HCS0.00-1

#### 4.1.2.6.1 Order data

Order number	Short description	Figure
	<b>ACOPOSremote inverter units</b>	
8CVI088E1HCS0.00-1	ACOPOSremote ACOPOSmulti65 inverter module, 8.8 A, AS, IP65, 1x SinCos EnDat 2.1/SSI/BiSS encoder interface, cold plate mounting	
	<b>Optional accessories</b>	
	<b>1.5 mm² motor cables</b>	
8CCM0003.11110-0	ACOPOSremote motor cable, length 3 m, 4x 1.5 mm² + 2x 2x 0.75 mm², 8-pin female speedtec motor connector size 1, 8-pin male speedtec servo connector size 1, can be used in cable drag chains	
8CCM0005.11110-0	ACOPOSremote motor cable, length 5 m, 4x 1.5 mm² + 2x 2x 0.75 mm², 8-pin female speedtec motor connector size 1, 8-pin male speedtec servo connector size 1, can be used in cable drag chains	
8CCM0010.11110-0	ACOPOSremote motor cable, length 10 m, 4x 1.5 mm² + 2x 2x 0.75 mm², 8-pin female speedtec motor connector size 1, 8-pin male speedtec servo connector size 1, can be used in cable drag chains	
8CCM0015.11110-0	ACOPOSremote motor cable, length 15 m, 4x 1.5 mm² + 2x 2x 0.75 mm², 8-pin female speedtec motor connector size 1, 8-pin male speedtec servo connector size 1, can be used in cable drag chains	
	<b>8BVE / 8CVI connection cables</b>	
8CCH0005.11120-1	Hybrid cable for connecting 8BVE to 8CVI or 8DI, length 5 m, 2x 2x 0.34 mm² + 4x 0.75 mm² + 5x 2.5 mm², 1x 15-pin female TYCO connector, 1x RJ45 connector, integrated shield fixing, can be used in cable drag chains	
8CCH0007.11120-1	Hybrid cable for connecting 8BVE to 8CVI or 8DI, length 7 m, 2x 2x 0.34 mm² + 4x 0.75 mm² + 5x 2.5 mm², 1x 15-pin female TYCO connector, 1x RJ45 connector, integrated shield fixing, can be used in cable drag chains	
8CCH0010.11120-1	Hybrid cable for connecting 8BVE to 8CVI or 8DI, length 10 m, 2x 2x 0.34 mm² + 4x 0.75 mm² + 5x 2.5 mm², 1x 15-pin female TYCO connector, 1x RJ45 connector, integrated shield fixing, can be used in cable drag chains	
	<b>Accessory sets</b>	
8CXC000.0000-00	Accessory set: 1x slot cover for hybrid connector	
8CXM000.0000-00	ACOPOSremote accessory set: 4x hex socket screw M6x80mm for 8CVI inverter modules	
	<b>EnDat 2.1 cables</b>	
8CCE0003.11210-0	ACOPOSremote EnDat 2.1 cable, length 3 m, 10x 0.14 mm² + 2x 0.5 mm², 17-pin female speedtec motor connector, 15-pin male series 615 signal connector, can be used in cable drag chains	
8CCE0005.11210-0	ACOPOSremote EnDat 2.1 cable, length 5 m, 10x 0.14 mm² + 2x 0.5 mm², 17-pin female speedtec motor connector, 15-pin male series 615 signal connector, can be used in cable drag chains	
	<b>Hybrid cables</b>	
8CCH0003.11110-1	Hybrid cable, length 3 m, 2x 2x 0.34 mm² + 4x 0.75 mm² + 5x 2.5 mm², 2x 15-pin female TYCO connector, can be used in cable drag chains	
8CCH0003.11130-1	Hybrid cable, length 3 m, 2x 2x 0.34 mm² + 4x 0.75 mm² + 5x 2.5 mm², 2x 15-pin female TYCO connector, 1x connector insert rotated 180°, can be used in cable drag chains	
8CCH0005.11110-1	Hybrid cable, length 5 m, 2x 2x 0.34 mm² + 4x 0.75 mm² + 5x 2.5 mm², 2x 15-pin female TYCO connector, can be used in cable drag chains	
8CCH0010.11110-1	Hybrid cable, length 10 m, 2x 2x 0.34 mm² + 4x 0.75 mm² + 5x 2.5 mm², 2x 15-pin female TYCO connector, can be used in cable drag chains	
8CCH0015.11110-1	Hybrid cable, length 15 m, 2x 2x 0.34 mm² + 4x 0.75 mm² + 5x 2.5 mm², 2x 15-pin female TYCO connector, can be used in cable drag chains	
8CCH0020.11110-1	Hybrid cable, length 20 m, 2x 2x 0.34 mm² + 4x 0.75 mm² + 5x 2.5 mm², 2x 15-pin female TYCO connector, can be used in cable drag chains	
	<b>One-sided hybrid cables</b>	
8CCH0005.11150-1	Hybrid cable for connecting 8EI to 8CVI or 8DI, length 5 m, 2x 2x 0.34 mm² + 4x 0.75 mm² + 5x 2.5 mm², 1x 15-pin female TYCO connector, 1x RJ45 connector, integrated shield fixing, can be used in cable drag chains	
8CCH0007.11150-1	Hybrid cable for connecting 8EI to 8CVI or 8DI, length 7 m, 2x 2x 0.34 mm² + 4x 0.75 mm² + 5x 2.5 mm², 1x 15-pin female TYCO connector, 1x RJ45 connector, integrated shield fixing, can be used in cable drag chains	

Table 12: 8CVI088E1HCS0.00-1 - Order data

Order number	Short description	Figure
8CCH0010.11150-1	Hybrid cable for connecting 8EI to 8CVI or 8DI, length 10 m, 2x 2x 0.34 mm <sup>2</sup> + 4x 0.75 mm <sup>2</sup> + 5x 2.5 mm <sup>2</sup> , 1x 15-pin female TYCO connector, 1x RJ45 connector, integrated shield fixing, can be used in cable drag chains	
8CCH0015.11150-1	Hybrid cable for connecting 8EI to 8CVI or 8DI, length 15 m, 2x 2x 0.34 mm <sup>2</sup> + 4x 0.75 mm <sup>2</sup> + 5x 2.5 mm <sup>2</sup> , 1x 15-pin female TYCO connector, 1x RJ45 connector, integrated shield fixing, can be used in cable drag chains	
8CCH0020.11150-1	Hybrid cable for connecting 8EI to 8CVI or 8DI, length 20 m, 2x 2x 0.34 mm <sup>2</sup> + 4x 0.75 mm <sup>2</sup> + 5x 2.5 mm <sup>2</sup> , 1x 15-pin female TYCO connector, 1x RJ45 connector, integrated shield fixing, can be used in cable drag chains	
8CCH0025.11150-1	Hybrid cable for connecting 8EI to 8CVI or 8DI, length 25 m, 2x 2x 0.34 mm <sup>2</sup> + 4x 0.75 mm <sup>2</sup> + 5x 2.5 mm <sup>2</sup> , 1x 15-pin female TYCO connector, 1x RJ45 connector, integrated shield fixing, can be used in cable drag chains	
<b>Threaded caps</b>		
X67AC0M08	X67 M8 threaded caps, 50 pcs.	
X67AC0M12	X67 M12 threaded caps, 50 pcs.	

Table 12: 8CVI088E1HCS0.00-1 - Order data

#### 4.1.2.6.2 Technical data

Order number	8CVI088E1HCS0.00-1	
<b>General information</b>		
Module type	ACOPOSremote module	
B&R ID code	0xDDA4	
Current-carrying capacity of 15-pin TYCO connector		
Power contacts	Max. 20 A at 40°C	
Support		
Dynamic node allocation (DNA)	Yes	
Cooling and mounting type	Cold plate mounting	
Certifications		
CE	Yes	
Functional safety <sup>1)</sup>	Yes	
UL	cULus E225616 Power conversion equipment	
<b>DC bus connection</b>		
Voltage		
Nominal	750 VDC	
Continuous power consumption <sup>2)</sup>	In preparation	
Power dissipation depending on switching frequency		
Switching frequency 5 kHz	$[0.16 * I_M^2 + 5.6 * I_M + 55 + (P_{out}/750)^2 * 0.25]$ W	
Switching frequency 10 kHz	$[0.49 * I_M^2 + 4.7 * I_M + 95 + (P_{out}/750)^2 * 0.25]$ W	
Switching frequency 20 kHz	$[0.87 * I_M^2 + 10 * I_M + 200 + (P_{out}/750)^2 * 0.25]$ W	
DC bus capacitance	35 µF	
Variant	15-pin male TYCO connector <sup>3)</sup>	
Line length		
Maximum	30 m	
<b>24 VDC power supply</b>		
Input voltage	24 VDC +20% / -25%	
Input capacitance	In preparation	
Max. power consumption	$10 \text{ W} + P_{24 \text{ V out}} + P_{\text{Holding brake}} + P_{\text{Trigger}}^4)$	
Variant	15-pin male TYCO connector <sup>3)</sup>	
Line length		
Maximum	30 m	
<b>24 VDC output</b>		
Quantity	1	
Output voltage	Depends on the 24 VDC power supply	
Continuous current	Max. 8 A (max. 4 A per pin)	
Fuse protection	Electronic (per pin)	
Variant		
24 VDC, COM	M8 connector	
<b>Motor connection</b>		
Quantity	1	
Continuous power per motor connection <sup>2)</sup>	4 kW	
Continuous current per motor connection <sup>2)</sup>	8.8 A <sub>eff</sub>	

Table 13: 8CVI088E1HCS0.00-1 - Technical data

## Technical data

Order number	8CVI088E1HCS0.00-1
Reduction of continuous current depending on switching frequency <sup>5)</sup>	
Switching frequency 5 kHz	No reduction <sup>6)</sup>
Switching frequency 10 kHz	No reduction
Switching frequency 20 kHz	No reduction
Reduction of continuous current depending on installation elevation	
Starting at 500 m above sea level	0.88 A per 1,000 m
Peak current	24.5 A <sub>eff</sub>
Nominal switching frequency	5 kHz
Possible switching frequencies <sup>7)</sup>	5 / 10 / 20 kHz
Insulation stress of the connected motor per IEC TS 60034-25:2004 <sup>8)</sup>	Limit value curve A
Protective measures	
Overload protection	Yes
Short-circuit and ground fault protection	Yes
Max. output frequency	598 Hz <sup>9)</sup>
Variant	
U, V, W, PE	8-pin speedtec connector, size 1
Shield connection	Yes (via connector housing)
Max. motor line length depending on switching frequency	
Switching frequency 5 kHz	10 m
Switching frequency 10 kHz	5 m
Switching frequency 20 kHz	5 m
<b>Motor holding brake connection</b>	
Quantity	1
Output voltage <sup>10)</sup>	24 VDC +5.8% / -0%
Continuous current per connection	1.1 A
Max. internal resistance	In preparation
Extinction potential	Approx. 30 V
Max. extinction energy per switching operation	1.5 Ws
Max. switching frequency	0.5 Hz
Protective measures	
Overload and short-circuit protection	Yes
Open-circuit monitoring	Yes
Undervoltage monitoring	Yes
Response threshold for open-circuit monitoring	Approx. 0.25 A
Response threshold for undervoltage monitoring	24 VDC +0% / -4%
<b>Fieldbus</b>	
Type	POWERLINK (V1/V2) 100BASE-T (ANSI/IEE 802.3)
Variant	Internal 3-port hub, 2x male 15-pin TYCO connector, 1x M12 connector
Line length	Max. 100 m between two stations (segment length) <sup>11)</sup>
Transfer rate	100 Mbit/s
<b>Encoder inputs</b>	
Quantity	1
Type	EnDat 2.1
Module-side connection	15-pin female springtec connector
Status indicators	UP/DN LEDs
Electrical isolation	
Encoder - ACOPOSremote	No
Encoder monitoring	Yes
Max. encoder cable length	10 m
Encoder power supply	
Output voltage	5 V ±5%
Load capacity	250 mA <sup>12)</sup>
Sense lines	2, compensation of max. 2 x 0.7 V
Protective measures	
Overload-proof	Yes
Short-circuit proof	Yes
Sine/Cosine inputs	
Signal transmission	Differential signals, symmetrical
Signal frequency (-3 dB)	DC up to 300 kHz
Signal frequency (-5 dB)	DC up to 400 kHz
Differential voltage	0.5 to 1.25 V <sub>ss</sub>
Common-mode voltage	Max. ±7 V
Terminating resistor	120 Ω
Resolution	12-bit

Table 13: 8CVI088E1HCS0.00-1 - Technical data

Order number	8CVI088E1HCS0.00-1
Reference input	
Signal transmission	Differential signal, symmetrical
Differential voltage for low	≤ -0.2 V
Differential voltage for high	≥ 0.2 V
Common-mode voltage	Max. ±7 V
Terminating resistor	120 Ω
Position	
Resolution @ 1 V <sub>SS</sub> <sup>13)</sup>	Number of encoder lines * 5700
Accuracy <sup>14)</sup>	-
Noise <sup>14)</sup>	-
Synchronous serial interface	
Signal transmission	RS485
Data transfer rate	Depends on the configured functionality <sup>15)</sup>
<b>Enable inputs</b>	
Quantity	2
Circuit	Sink
Electrical isolation	
Input - Inverter module	Yes
Input - Input	Yes
Input voltage	
Nominal	24 VDC
Maximum	30 VDC
Input current at nominal voltage	Approx. 30 mA
Switching threshold	
Low	<5 V
High	>15 V
Switching delay at nominal input voltage	
Enable 1 → 0, PWM off	Max. 20.5 ms
Enable 0 → 1, ready for PWM	Max. 100 μs
Modulation compared to ground potential	Max. ±38 V
OSSD signal connections <sup>16)</sup>	Permitted Max. test pulse length: 500 μs
Variant	15-pin male TYCO connector <sup>3)</sup>
<b>Trigger inputs</b>	
Quantity	2
Circuit	Sink
Electrical isolation	
Input - Inverter module	No
Input - Input	No
Input voltage	
Nominal	24 VDC
Maximum	30 VDC
Switching threshold	
Low	<5 V
High	>15 V
Input current at nominal voltage	In preparation
Switching delay	
Rising edge	In preparation
Falling edge	In preparation
Modulation compared to ground potential	In preparation
Max. line length	30 m
Variant	M8 connector
<b>Temperature sensor connection</b>	
Quantity	1
Resistance range	500 Ω to 5 kΩ
<b>Support</b>	
Software	
ACP10	V2.35.1 and higher
<b>Electrical properties</b>	
Discharge capacitance	0.1 μF
<b>Operating conditions</b>	
Permissible mounting orientations	
Hanging vertically	Yes
Horizontal, face up	Yes
Standing horizontally	Yes
Installation elevation above sea level	
Nominal	0 to 500 m
Maximum <sup>17)</sup>	4000 m
Pollution degree per EN 61800-5-1	2 (non-conductive pollution)
Overvoltage category per EN 61800-5-1	III
Degree of protection per EN 60529	IP65 <sup>18)</sup>

Table 13: 8CVI088E1HCS0.00-1 - Technical data

## Technical data

Order number	8CVI088E1HCS0.00-1
<b>Ambient conditions</b>	
Temperature	
Operation	
Nominal	5 to 40°C <sup>19)</sup>
Maximum	60°C
Storage	-25 to 55°C
Transport	-25 to 70°C
Relative humidity	
Operation	5 to 85%, non-condensing
Storage	5 to 95%, non-condensing
Transport	Max. 95% at 40°C
<b>Mechanical properties</b>	
Dimensions <sup>20)</sup>	
Width	137 mm
Height	287.2 mm
Depth	131 mm
Weight	4.8 kg

Table 13: 8CVI088E1HCS0.00-1 - Technical data

- 1) Achievable safety classifications (safety integrity level, safety category, performance level) are documented in the user's manual (section "Safety technology").
- 2) Valid under the following conditions: 750 VDC DC bus voltage, 5 kHz switching frequency, 40°C ambient temperature, installation elevation <500 m above sea level, no derating due to cooling type.
- 3) It is important to note that the 15-pin male TYCO connector is designed for max. 20 mating cycles.
- 4) The power consumption  $P_{24V_{Out}}$  corresponds to the portion of the power that is output on the X31 connector on the module.
- 5) Valid under the following conditions: 750 VDC DC bus voltage. The temperature specifications refer to the ambient temperature.
- 6) Value for the nominal switching frequency.
- 7) B&R recommends operating the module at its nominal switching frequency. Operating the module at a higher switching frequency for application-specific reasons reduces the continuous current and increases CPU utilization.
- 8) If necessary, the stress of the motor isolation system can be reduced by an additional externally wired dv/dt choke. For example, the RWK 305 three-phase dv/dt choke from Schaffner ([www.schaffner.com](http://www.schaffner.com)) can be used. IMPORTANT: Even when using a dv/dt choke, it is necessary to ensure that an EMC-compatible, low inductance shield connection is used!
- 9) The module's electrical output frequency (SCTRL\_SPEED\_ACT \* MOTOR\_POLEPAIRS) is monitored to protect against dual use in accordance with Regulation (EC) 428/2009 | 3A225. If the electrical output frequency of the module exceeds the limit value of 598 Hz uninterrupted for more than 0.5 s, then the current movement is aborted and error 6060 is output ("Power unit: Limit speed exceeded").
- 10) During configuration, it is necessary to check if the minimum voltage can be maintained on the holding brake with the intended wiring. For the operating voltage range of the holding brake, see the user documentation for the motor being used.
- 11) Limited to 30 m when using hybrid cables.
- 12) An additional reserve of 57 mA is available for terminating resistors.
- 13) This value does not correspond to the encoder resolution that must be configured in Automation Studio (16384 \* number of encoder lines).
- 14) Limited by the encoder in practice.
- 15) EnDat 2.1 ... 781.25 kbit/s, SSI ... 100 to 400 kbit/s, BiSS ... 1560 kbit/s.
- 16) Output signal switching device (OSSD) signals are used for monitoring signal lines for short circuits and cross faults.
- 17) Continuous operation at an installation elevation of 500 m to 4,000 m above sea level is possible taking the specified reduction of continuous current into account. Requirements that go beyond this must be arranged with B&R.
- 18) The specified degree of protection is only met if all connectors on the module that are not being used are closed with suitable threaded caps or slot covers! Suitable threaded caps or slot covers are available as optional accessories (X67AC0M08, X67AC0M12, 8CXC000.0000-00). The module is delivered with IP20 protection.
- 19) The temperature of the module's mounting surface is not permitted to exceed 60°C.
- 20) The dimensions refer to the actual device dimensions. Additional spacing above and below the devices must be taken into account for mounting and connection.

### 4.1.2.7 8CVI088H1HCS0.00-1

#### 4.1.2.7.1 Order data

Order number	Short description	Figure
	<b>ACOPOSremote inverter units</b>	
8CVI088H1HCS0.00-1	ACOPOSremote ACOPOSmulti65 inverter module, 8.8 A, AS, IP65, 1x HIPERFACE encoder interface, cold plate mounting	
	<b>Optional accessories</b>	
	<b>1.5 mm² motor cables</b>	
8CCM0003.11110-0	ACOPOSremote motor cable, length 3 m, 4x 1.5 mm² + 2x 2x 0.75 mm², 8-pin female speedtec motor connector size 1, 8-pin male speedtec servo connector size 1, can be used in cable drag chains	
8CCM0005.11110-0	ACOPOSremote motor cable, length 5 m, 4x 1.5 mm² + 2x 2x 0.75 mm², 8-pin female speedtec motor connector size 1, 8-pin male speedtec servo connector size 1, can be used in cable drag chains	
8CCM0010.11110-0	ACOPOSremote motor cable, length 10 m, 4x 1.5 mm² + 2x 2x 0.75 mm², 8-pin female speedtec motor connector size 1, 8-pin male speedtec servo connector size 1, can be used in cable drag chains	
8CCM0015.11110-0	ACOPOSremote motor cable, length 15 m, 4x 1.5 mm² + 2x 2x 0.75 mm², 8-pin female speedtec motor connector size 1, 8-pin male speedtec servo connector size 1, can be used in cable drag chains	
	<b>8BVE / 8CVI connection cables</b>	
8CCH0005.11120-1	Hybrid cable for connecting 8BVE to 8CVI or 8DI, length 5 m, 2x 2x 0.34 mm² + 4x 0.75 mm² + 5x 2.5 mm², 1x 15-pin female TYCO connector, 1x RJ45 connector, integrated shield fixing, can be used in cable drag chains	
8CCH0007.11120-1	Hybrid cable for connecting 8BVE to 8CVI or 8DI, length 7 m, 2x 2x 0.34 mm² + 4x 0.75 mm² + 5x 2.5 mm², 1x 15-pin female TYCO connector, 1x RJ45 connector, integrated shield fixing, can be used in cable drag chains	
8CCH0010.11120-1	Hybrid cable for connecting 8BVE to 8CVI or 8DI, length 10 m, 2x 2x 0.34 mm² + 4x 0.75 mm² + 5x 2.5 mm², 1x 15-pin female TYCO connector, 1x RJ45 connector, integrated shield fixing, can be used in cable drag chains	
	<b>Accessory sets</b>	
8CXC000.0000-00	Accessory set: 1x slot cover for hybrid connector	
8CXM000.0000-00	ACOPOSremote accessory set: 4x hex socket screw M6x80mm for 8CVI inverter modules	
	<b>Hybrid cables</b>	
8CCH0003.11110-1	Hybrid cable, length 3 m, 2x 2x 0.34 mm² + 4x 0.75 mm² + 5x 2.5 mm², 2x 15-pin female TYCO connector, can be used in cable drag chains	
8CCH0003.11130-1	Hybrid cable, length 3 m, 2x 2x 0.34 mm² + 4x 0.75 mm² + 5x 2.5 mm², 2x 15-pin female TYCO connector, 1x connector insert rotated 180°, can be used in cable drag chains	
8CCH0005.11110-1	Hybrid cable, length 5 m, 2x 2x 0.34 mm² + 4x 0.75 mm² + 5x 2.5 mm², 2x 15-pin female TYCO connector, can be used in cable drag chains	
8CCH0010.11110-1	Hybrid cable, length 10 m, 2x 2x 0.34 mm² + 4x 0.75 mm² + 5x 2.5 mm², 2x 15-pin female TYCO connector, can be used in cable drag chains	
8CCH0015.11110-1	Hybrid cable, length 15 m, 2x 2x 0.34 mm² + 4x 0.75 mm² + 5x 2.5 mm², 2x 15-pin female TYCO connector, can be used in cable drag chains	
8CCH0020.11110-1	Hybrid cable, length 20 m, 2x 2x 0.34 mm² + 4x 0.75 mm² + 5x 2.5 mm², 2x 15-pin female TYCO connector, can be used in cable drag chains	
	<b>One-sided hybrid cables</b>	
8CCH0005.11150-1	Hybrid cable for connecting 8EI to 8CVI or 8DI, length 5 m, 2x 2x 0.34 mm² + 4x 0.75 mm² + 5x 2.5 mm², 1x 15-pin female TYCO connector, 1x RJ45 connector, integrated shield fixing, can be used in cable drag chains	
8CCH0007.11150-1	Hybrid cable for connecting 8EI to 8CVI or 8DI, length 7 m, 2x 2x 0.34 mm² + 4x 0.75 mm² + 5x 2.5 mm², 1x 15-pin female TYCO connector, 1x RJ45 connector, integrated shield fixing, can be used in cable drag chains	
8CCH0010.11150-1	Hybrid cable for connecting 8EI to 8CVI or 8DI, length 10 m, 2x 2x 0.34 mm² + 4x 0.75 mm² + 5x 2.5 mm², 1x 15-pin female TYCO connector, 1x RJ45 connector, integrated shield fixing, can be used in cable drag chains	
8CCH0015.11150-1	Hybrid cable for connecting 8EI to 8CVI or 8DI, length 15 m, 2x 2x 0.34 mm² + 4x 0.75 mm² + 5x 2.5 mm², 1x 15-pin female TYCO connector, 1x RJ45 connector, integrated shield fixing, can be used in cable drag chains	

Table 14: 8CVI088H1HCS0.00-1 - Order data

## Technical data

Order number	Short description	Figure
8CCH0020.11150-1	Hybrid cable for connecting 8EI to 8CVI or 8DI, length 20 m, 2x 2x 0.34 mm <sup>2</sup> + 4x 0.75 mm <sup>2</sup> + 5x 2.5 mm <sup>2</sup> , 1x 15-pin female TYCO connector, 1x RJ45 connector, integrated shield fixing, can be used in cable drag chains	
8CCH0025.11150-1	Hybrid cable for connecting 8EI to 8CVI or 8DI, length 25 m, 2x 2x 0.34 mm <sup>2</sup> + 4x 0.75 mm <sup>2</sup> + 5x 2.5 mm <sup>2</sup> , 1x 15-pin female TYCO connector, 1x RJ45 connector, integrated shield fixing, can be used in cable drag chains	
<b>Threaded caps</b>		
X67AC0M08	X67 M8 threaded caps, 50 pcs.	
X67AC0M12	X67 M12 threaded caps, 50 pcs.	

Table 14: 8CVI088H1HCS0.00-1 - Order data

### 4.1.2.7.2 Technical data

Order number	8CVI088H1HCS0.00-1
<b>General information</b>	
Module type	ACOPOSremote module
B&R ID code	0xDDA5
Current-carrying capacity of 15-pin TYCO connector	
Power contacts	Max. 20 A at 40°C
Support	
Dynamic node allocation (DNA)	Yes
Cooling and mounting type	Cold plate mounting
Certifications	
CE	Yes
Functional safety <sup>1)</sup>	Yes
UL	cULus E225616 Power conversion equipment
<b>DC bus connection</b>	
Voltage	
Nominal	750 VDC
Continuous power consumption <sup>2)</sup>	In preparation
Power dissipation depending on switching frequency	
Switching frequency 5 kHz	$[0.16 * I_M^2 + 5.6 * I_M + 55 + (P_{out}/750)^2 * 0.25]$ W
Switching frequency 10 kHz	$[0.49 * I_M^2 + 4.7 * I_M + 95 + (P_{out}/750)^2 * 0.25]$ W
Switching frequency 20 kHz	$[0.87 * I_M^2 + 10 * I_M + 200 + (P_{out}/750)^2 * 0.25]$ W
DC bus capacitance	35 µF
Variant	15-pin male TYCO connector <sup>3)</sup>
Line length	
Maximum	30 m
<b>24 VDC power supply</b>	
Input voltage	24 VDC +20% / -25%
Input capacitance	In preparation
Max. power consumption	$10 \text{ W} + P_{24 \text{ V out}} + P_{\text{Holding brake}} + P_{\text{Trigger}}^{4)}$
Variant	15-pin male TYCO connector <sup>3)</sup>
Line length	
Maximum	30 m
<b>24 VDC output</b>	
Quantity	1
Output voltage	Depends on the 24 VDC power supply
Continuous current	Max. 8 A (max. 4 A per pin)
Fuse protection	Electronic (per pin)
Variant	
24 VDC, COM	M8 connector
<b>Motor connection</b>	
Quantity	1
Continuous power per motor connection <sup>2)</sup>	4 kW
Continuous current per motor connection <sup>2)</sup>	8.8 A <sub>eff</sub>
Reduction of continuous current depending on switching frequency <sup>5)</sup>	
Switching frequency 5 kHz	No reduction <sup>6)</sup>
Switching frequency 10 kHz	No reduction
Switching frequency 20 kHz	No reduction
Reduction of continuous current depending on installation elevation	
Starting at 500 m above sea level	0.88 A per 1,000 m
Peak current	24.5 A <sub>eff</sub>
Nominal switching frequency	5 kHz
Possible switching frequencies <sup>7)</sup>	5 / 10 / 20 kHz

Table 15: 8CVI088H1HCS0.00-1 - Technical data

Order number	8CVI088H1HCS0.00-1
Insulation stress of the connected motor per IEC TS 60034-25:2004 <sup>8)</sup>	Limit value curve A
Protective measures	
Overload protection	Yes
Short-circuit and ground fault protection	Yes
Max. output frequency	598 Hz <sup>9)</sup>
Variant	
U, V, W, PE	8-pin speedtec connector, size 1
Shield connection	Yes (via connector housing)
Max. motor line length depending on switching frequency	
Switching frequency 5 kHz	10 m
Switching frequency 10 kHz	5 m
Switching frequency 20 kHz	5 m
<b>Motor holding brake connection</b>	
Quantity	1
Output voltage <sup>10)</sup>	24 VDC +5.8% / -0%
Continuous current per connection	1.1 A
Max. internal resistance	In preparation
Extinction potential	Approx. 30 V
Max. extinction energy per switching operation	1.5 Ws
Max. switching frequency	0.5 Hz
Protective measures	
Overload and short-circuit protection	Yes
Open-circuit monitoring	Yes
Undervoltage monitoring	Yes
Response threshold for open-circuit monitoring	Approx. 0.25 A
Response threshold for undervoltage monitoring	24 VDC +0% / -4%
<b>Fieldbus</b>	
Type	POWERLINK (V1/V2) 100BASE-T (ANSI/IEE 802.3)
Variant	Internal 3-port hub, 2x male 15-pin TYCO connector, 1x M12 connector
Line length	Max. 100 m between two stations (segment length) <sup>11)</sup>
Transfer rate	100 Mbit/s
<b>Encoder inputs</b>	
Quantity	1
Type	HIPERFACE
Module-side connection	15-pin female springtec connector
Status indicators	UP/DN LEDs
Electrical isolation	
Encoder - ACOPOSremote	No
Encoder monitoring	Yes
Max. encoder cable length	10 m
Encoder power supply	
Output voltage	Typ. 10 V
Load capacity	130 mA <sup>12)</sup>
Sense lines	-
Protective measures	
Overload-proof	Yes
Short-circuit proof	Yes
Sine/Cosine inputs	
Signal transmission	Differential signal, asymmetrical
Signal frequency	DC up to 200 kHz
Differential voltage	0.5 to 1.25 V <sub>SS</sub>
Common-mode voltage	Max. ±7 V
Terminating resistor	120 Ω
Resolution	12-bit
Position	
Resolution @ 1 V <sub>SS</sub> <sup>13)</sup>	Number of encoder lines * 5700
Accuracy <sup>14)</sup>	-
Noise <sup>14)</sup>	-
Asynchronous serial interface	
Signal transmission	RS485
Data transfer rate	9600 bit/s
<b>Enable inputs</b>	
Quantity	2
Circuit	Sink
Electrical isolation	
Input - Inverter module	Yes
Input - Input	Yes
Input voltage	
Nominal	24 VDC
Maximum	30 VDC
Input current at nominal voltage	Approx. 30 mA

Table 15: 8CVI088H1HCS0.00-1 - Technical data

## Technical data

Order number	8CVI088H1HCS0.00-1
Switching threshold	
Low	<5 V
High	>15 V
Switching delay at nominal input voltage	
Enable 1 → 0, PWM off	Max. 20.5 ms
Enable 0 → 1, ready for PWM	Max. 100 µs
Modulation compared to ground potential	Max. ±38 V
OSSD signal connections <sup>15)</sup>	Permitted Max. test pulse length: 500 µs
Variant	15-pin male TYCO connector <sup>3)</sup>
<b>Trigger inputs</b>	
Quantity	2
Circuit	Sink
Electrical isolation	
Input - Inverter module	No
Input - Input	No
Input voltage	
Nominal	24 VDC
Maximum	30 VDC
Switching threshold	
Low	<5 V
High	>15 V
Input current at nominal voltage	In preparation
Switching delay	
Rising edge	In preparation
Falling edge	In preparation
Modulation compared to ground potential	In preparation
Max. line length	30 m
Variant	M8 connector
Sensor/Actuator power supply	
Voltage	24 VDC
Summation current	Max. 250 mA <sup>16)</sup>
<b>Temperature sensor connection</b>	
Quantity	1
Resistance range	500 Ω to 5 kΩ
<b>Support</b>	
Software	
ACP10	V2.28.0 and higher
<b>Electrical properties</b>	
Discharge capacitance	0.1 µF
<b>Operating conditions</b>	
Permissible mounting orientations	
Hanging vertically	Yes
Horizontal, face up	Yes
Standing horizontally	Yes
Installation elevation above sea level	
Nominal	0 to 500 m
Maximum <sup>17)</sup>	4000 m
Pollution degree per EN 61800-5-1	2 (non-conductive pollution)
Overvoltage category per EN 61800-5-1	III
Degree of protection per EN 60529	IP65 <sup>18)</sup>
<b>Ambient conditions</b>	
Temperature	
Operation	
Nominal	5 to 40°C <sup>19)</sup>
Maximum	60°C
Storage	-25 to 55°C
Transport	-25 to 70°C
Relative humidity	
Operation	5 to 85%, non-condensing
Storage	5 to 95%, non-condensing
Transport	Max. 95% at 40°C
<b>Mechanical properties</b>	
Dimensions <sup>20)</sup>	
Width	137 mm
Height	287.2 mm
Depth	131 mm
Weight	4.8 kg

Table 15: 8CVI088H1HCS0.00-1 - Technical data

- 1) Achievable safety classifications (safety integrity level, safety category, performance level) are documented in the user's manual (section "Safety technology").
- 2) Valid under the following conditions: 750 VDC DC bus voltage, 5 kHz switching frequency, 40°C ambient temperature, installation elevation <500 m above sea level, no derating due to cooling type.
- 3) It is important to note that the 15-pin male TYCO connector is designed for max. 20 mating cycles.

- 4) The power consumption  $P_{24V Out}$  corresponds to the portion of the power that is output on the X31 connector on the module.
- 5) Valid under the following conditions: 750 VDC DC bus voltage. The temperature specifications refer to the ambient temperature.
- 6) Value for the nominal switching frequency.
- 7) B&R recommends operating the module at its nominal switching frequency. Operating the module at a higher switching frequency for application-specific reasons reduces the continuous current and increases CPU utilization.
- 8) If necessary, the stress of the motor isolation system can be reduced by an additional externally wired dv/dt choke. For example, the RWK 305 three-phase dv/dt choke from Schaffner ([www.schaffner.com](http://www.schaffner.com)) can be used. IMPORTANT: Even when using a dv/dt choke, it is necessary to ensure that an EMC-compatible, low inductance shield connection is used!
- 9) The module's electrical output frequency (SCTRL\_SPEED\_ACT \* MOTOR\_POLEPAIRS) is monitored to protect against dual use in accordance with Regulation (EC) 428/2009 | 3A225. If the electrical output frequency of the module exceeds the limit value of 598 Hz uninterrupted for more than 0.5 s, then the current movement is aborted and error 6060 is output ("Power unit: Limit speed exceeded").
- 10) During configuration, it is necessary to check if the minimum voltage can be maintained on the holding brake with the intended wiring. For the operating voltage range of the holding brake, see the user documentation for the motor being used.
- 11) Limited to 30 m when using hybrid cables.
- 12) An additional reserve of 40 mA is available for terminating resistors.
- 13) This value does not correspond to the encoder resolution that must be configured in Automation Studio (16384 \* number of encoder lines).
- 14) Limited by the encoder in practice.
- 15) Output signal switching device (OSSD) signals are used for monitoring signal lines for short circuits and cross faults.
- 16) The summation current corresponds to the current that is output on the X23A and X24A connectors on the module.
- 17) Continuous operation at an installation elevation of 500 m to 4,000 m above sea level is possible taking the specified reduction of continuous current into account. Requirements that go beyond this must be arranged with B&R.
- 18) The specified degree of protection is only met if all connectors on the module that are not being used are closed with suitable threaded caps or slot covers! Suitable threaded caps or slot covers are available as optional accessories (X67AC0M08, X67AC0M12, 8CXC000.0000-00). The module is delivered with IP20 protection.
- 19) The temperature of the module's mounting surface is not permitted to exceed 60°C.
- 20) The dimensions refer to the actual device dimensions. Additional spacing above and below the devices must be taken into account for mounting and connection.

### 4.1.2.8 8CVI155S1HCS0.01-1

#### 4.1.2.8.1 Order data

Order number	Short description	Figure
	<b>ACOPOSremote inverter units</b>	
8CVI155S1HCS0.01-1	ACOPOSremote ACOPOSmulti65 inverter module, 15.5 A, AS, IP65, integrated cold plate, 1x SinCos encoder interface, cold plate mounting	
	<b>Optional accessories</b>	
	<b>1.5 mm² motor cables</b>	
8CCM0003.11110-0	ACOPOSremote motor cable, length 3 m, 4x 1.5 mm² + 2x 2x 0.75 mm², 8-pin female speedtec motor connector size 1, 8-pin male speedtec servo connector size 1, can be used in cable drag chains	
8CCM0005.11110-0	ACOPOSremote motor cable, length 5 m, 4x 1.5 mm² + 2x 2x 0.75 mm², 8-pin female speedtec motor connector size 1, 8-pin male speedtec servo connector size 1, can be used in cable drag chains	
8CCM0010.11110-0	ACOPOSremote motor cable, length 10 m, 4x 1.5 mm² + 2x 2x 0.75 mm², 8-pin female speedtec motor connector size 1, 8-pin male speedtec servo connector size 1, can be used in cable drag chains	
8CCM0015.11110-0	ACOPOSremote motor cable, length 15 m, 4x 1.5 mm² + 2x 2x 0.75 mm², 8-pin female speedtec motor connector size 1, 8-pin male speedtec servo connector size 1, can be used in cable drag chains	
	<b>8BVE / 8CVI connection cables</b>	
8CCH0005.11120-1	Hybrid cable for connecting 8BVE to 8CVI or 8DI, length 5 m, 2x 2x 0.34 mm² + 4x 0.75 mm² + 5x 2.5 mm², 1x 15-pin female TYCO connector, 1x RJ45 connector, integrated shield fixing, can be used in cable drag chains	
8CCH0007.11120-1	Hybrid cable for connecting 8BVE to 8CVI or 8DI, length 7 m, 2x 2x 0.34 mm² + 4x 0.75 mm² + 5x 2.5 mm², 1x 15-pin female TYCO connector, 1x RJ45 connector, integrated shield fixing, can be used in cable drag chains	
8CCH0010.11120-1	Hybrid cable for connecting 8BVE to 8CVI or 8DI, length 10 m, 2x 2x 0.34 mm² + 4x 0.75 mm² + 5x 2.5 mm², 1x 15-pin female TYCO connector, 1x RJ45 connector, integrated shield fixing, can be used in cable drag chains	
	<b>Accessory sets</b>	
8CXC000.0000-00	Accessory set: 1x slot cover for hybrid connector	
8CXM000.0000-00	ACOPOSremote accessory set: 4x hex socket screw M6x80mm for 8CVI inverter modules	
	<b>Hybrid cables</b>	
8CCH0003.11110-1	Hybrid cable, length 3 m, 2x 2x 0.34 mm² + 4x 0.75 mm² + 5x 2.5 mm², 2x 15-pin female TYCO connector, can be used in cable drag chains	
8CCH0003.11130-1	Hybrid cable, length 3 m, 2x 2x 0.34 mm² + 4x 0.75 mm² + 5x 2.5 mm², 2x 15-pin female TYCO connector, 1x connector insert rotated 180°, can be used in cable drag chains	
8CCH0005.11110-1	Hybrid cable, length 5 m, 2x 2x 0.34 mm² + 4x 0.75 mm² + 5x 2.5 mm², 2x 15-pin female TYCO connector, can be used in cable drag chains	
8CCH0010.11110-1	Hybrid cable, length 10 m, 2x 2x 0.34 mm² + 4x 0.75 mm² + 5x 2.5 mm², 2x 15-pin female TYCO connector, can be used in cable drag chains	
8CCH0015.11110-1	Hybrid cable, length 15 m, 2x 2x 0.34 mm² + 4x 0.75 mm² + 5x 2.5 mm², 2x 15-pin female TYCO connector, can be used in cable drag chains	
8CCH0020.11110-1	Hybrid cable, length 20 m, 2x 2x 0.34 mm² + 4x 0.75 mm² + 5x 2.5 mm², 2x 15-pin female TYCO connector, can be used in cable drag chains	
	<b>One-sided hybrid cables</b>	
8CCH0005.11150-1	Hybrid cable for connecting 8EI to 8CVI or 8DI, length 5 m, 2x 2x 0.34 mm² + 4x 0.75 mm² + 5x 2.5 mm², 1x 15-pin female TYCO connector, 1x RJ45 connector, integrated shield fixing, can be used in cable drag chains	
8CCH0007.11150-1	Hybrid cable for connecting 8EI to 8CVI or 8DI, length 7 m, 2x 2x 0.34 mm² + 4x 0.75 mm² + 5x 2.5 mm², 1x 15-pin female TYCO connector, 1x RJ45 connector, integrated shield fixing, can be used in cable drag chains	
8CCH0010.11150-1	Hybrid cable for connecting 8EI to 8CVI or 8DI, length 10 m, 2x 2x 0.34 mm² + 4x 0.75 mm² + 5x 2.5 mm², 1x 15-pin female TYCO connector, 1x RJ45 connector, integrated shield fixing, can be used in cable drag chains	
8CCH0015.11150-1	Hybrid cable for connecting 8EI to 8CVI or 8DI, length 15 m, 2x 2x 0.34 mm² + 4x 0.75 mm² + 5x 2.5 mm², 1x 15-pin female TYCO connector, 1x RJ45 connector, integrated shield fixing, can be used in cable drag chains	

Table 16: 8CVI155S1HCS0.01-1 - Order data

Order number	Short description	Figure
8CCH0020.11150-1	Hybrid cable for connecting 8EI to 8CVI or 8DI, length 20 m, 2x 2x 0.34 mm <sup>2</sup> + 4x 0.75 mm <sup>2</sup> + 5x 2.5 mm <sup>2</sup> , 1x 15-pin female TYCO connector, 1x RJ45 connector, integrated shield fixing, can be used in cable drag chains	
8CCH0025.11150-1	Hybrid cable for connecting 8EI to 8CVI or 8DI, length 25 m, 2x 2x 0.34 mm <sup>2</sup> + 4x 0.75 mm <sup>2</sup> + 5x 2.5 mm <sup>2</sup> , 1x 15-pin female TYCO connector, 1x RJ45 connector, integrated shield fixing, can be used in cable drag chains	
	<b>SinCos cables</b>	
8CCS0003.11110-0	ACOPOSremote EnDat 2.1 cable, length 3 m, 10x 0.14 mm <sup>2</sup> + 2x 0.5 mm <sup>2</sup> , 12-pin female series 615 signal connector, 15-pin male series 615 signal connector, can be used in cable drag chains	
8CCS0005.11110-0	ACOPOSremote EnDat 2.1 cable, length 5 m, 10x 0.14 mm <sup>2</sup> + 2x 0.5 mm <sup>2</sup> , 12-pin female series 615 signal connector, 15-pin male series 615 signal connector, can be used in cable drag chains	
8CCS0010.11110-0	ACOPOSremote EnDat 2.1 cable, length 10 m, 10x 0.14 mm <sup>2</sup> + 2x 0.5 mm <sup>2</sup> , 12-pin female series 615 signal connector, 15-pin male series 615 signal connector, can be used in cable drag chains	
8CCS0015.11110-0	ACOPOSremote EnDat 2.1 cable, length 15 m, 10x 0.14 mm <sup>2</sup> + 2x 0.5 mm <sup>2</sup> , 12-pin female series 615 signal connector, 15-pin male series 615 signal connector, can be used in cable drag chains	
	<b>Threaded caps</b>	
X67AC0M08	X67 M8 threaded caps, 50 pcs.	
X67AC0M12	X67 M12 threaded caps, 50 pcs.	

Table 16: 8CVI155S1HCS0.01-1 - Order data

#### 4.1.2.8.2 Technical data

Order number	8CVI155S1HCS0.01-1
<b>General information</b>	
Module type	ACOPOSremote module with integrated cold plate
B&R ID code	0xE9EB
Current-carrying capacity of 15-pin TYCO connector	
Power contacts	Max. 20 A at 40°C
Support	
Dynamic node allocation (DNA)	Yes
Cooling and mounting type	Wall mounting Water cooling
Certifications	
CE	Yes
Functional safety <sup>1)</sup>	Yes
UL	cULus E225616 Power conversion equipment
<b>DC bus connection</b>	
Voltage	
Nominal	750 VDC
Continuous power consumption <sup>2)</sup>	In preparation
Power dissipation depending on switching frequency	
Switching frequency 5 kHz	In preparation
Switching frequency 10 kHz	In preparation
Switching frequency 20 kHz	In preparation
DC bus capacitance	35 µF
Variant	15-pin male TYCO connector <sup>3)</sup>
Line length	
Maximum	30 m
<b>24 VDC power supply</b>	
Input voltage	24 VDC +20% / -25%
Input capacitance	In preparation
Max. power consumption	10 W + P <sub>24 V out</sub> + P <sub>Holding brake</sub> + P <sub>Trigger</sub> <sup>4)</sup>
Variant	15-pin male TYCO connector <sup>3)</sup>
Line length	
Maximum	30 m
<b>24 VDC output</b>	
Quantity	1
Output voltage	Depends on the 24 VDC power supply
Continuous current	Max. 8 A (max. 4 A per pin)
Fuse protection	Electronic (per pin)
Variant	
24 VDC, COM	M8 connector

Table 17: 8CVI155S1HCS0.01-1 - Technical data

## Technical data

Order number	8CVI155S1HCS0.01-1
<b>Motor connection</b>	
Quantity	1
Continuous power per motor connection <sup>2)</sup>	7.5 kW
Continuous current per motor connection <sup>2)</sup>	15.5 A <sub>eff</sub>
Reduction of continuous current depending on switching frequency <sup>5)</sup>	
Switching frequency 5 kHz	No reduction <sup>6)</sup>
Switching frequency 10 kHz	In preparation
Switching frequency 20 kHz	In preparation
Reduction of continuous current depending on installation elevation	
Starting at 500 m above sea level	1.4 A per 1,000 m
Peak current	40 A
Nominal switching frequency	5 kHz
Possible switching frequencies <sup>7)</sup>	5 / 10 / 20 kHz
Insulation stress of the connected motor per IEC TS 60034-25:2004 <sup>8)</sup>	Limit value curve A
Protective measures	
Overload protection	Yes
Short-circuit and ground fault protection	Yes
Max. output frequency	598 Hz <sup>9)</sup>
Variant	
U, V, W, PE	8-pin speedtec connector, size 1
Shield connection	Yes (via connector housing)
Max. motor line length depending on switching frequency	
Switching frequency 5 kHz	10 m
Switching frequency 10 kHz	5 m
Switching frequency 20 kHz	5 m
<b>Motor holding brake connection</b>	
Quantity	1
Output voltage <sup>10)</sup>	24 VDC +5.8% / -0%
Continuous current per connection	1.1 A
Max. internal resistance	In preparation
Extinction potential	Approx. 30 V
Max. extinction energy per switching operation	1.5 Ws
Max. switching frequency	0.5 Hz
Protective measures	
Overload and short-circuit protection	Yes
Open-circuit monitoring	Yes
Undervoltage monitoring	Yes
Response threshold for open-circuit monitoring	Approx. 0.25 A
Response threshold for undervoltage monitoring	24 VDC +0% / -4%
<b>Fieldbus</b>	
Type	POWERLINK (V1/V2) 100BASE-T (ANSI/IEE 802.3)
Variant	Internal 3-port hub, 2x male 15-pin TYCO connector, 1x M12 connector
Line length	Max. 100 m between two stations (segment length) <sup>11)</sup>
Transfer rate	100 Mbit/s
<b>Encoder inputs</b>	
Quantity	1
Type	SinCos
Module-side connection	15-pin female springtec connector
Status indicators	UP/DN LEDs
Electrical isolation	
Encoder - ACOPOSremote	No
Encoder monitoring	Yes
Max. encoder cable length	10 m
Encoder power supply	
Output voltage	5 V ±5%
Load capacity	300 mA <sup>12)</sup>
Sense lines	2, compensation of max. 2 x 0.7 V
Protective measures	
Overload-proof	Yes
Short-circuit proof	Yes
Sine/Cosine inputs	
Signal transmission	Differential signals, symmetrical
Signal frequency (-3 dB)	DC up to 300 kHz
Signal frequency (-5 dB)	DC up to 400 kHz
Differential voltage	0.5 to 1.25 V <sub>ss</sub>
Common-mode voltage	Max. ±7 V
Terminating resistor	120 Ω
ADC resolution	12-bit

Table 17: 8CVI155S1HCS0.01-1 - Technical data

Order number	8CVI155S1HCS0.01-1
Reference input	
Signal transmission	Differential signal, symmetrical
Differential voltage for low	$\leq -0.2$ V
Differential voltage for high	$\geq 0.2$ V
Common-mode voltage	Max. $\pm 7$ V
Terminating resistor	120 $\Omega$
Position	
Resolution @ 1 V <sub>SS</sub> <sup>13)</sup>	Number of encoder lines * 5700
Accuracy <sup>14)</sup>	-
Noise <sup>14)</sup>	-
Limit switch inputs <sup>15)</sup>	
Quantity	2
Circuit	Source
Input resistance	1470 $\Omega$
Electrical isolation	
Input - ACOPOSremote	No
Input - Input	No
Input voltage	
Minimum	-12 V
Nominal	5 V
Maximum	20 V
Switching threshold	
Low	<0.8 V
High	>2 V
Switching delay	Max. 100 $\mu$ s
<b>Enable inputs</b>	
Quantity	2
Circuit	Sink
Electrical isolation	
Input - Inverter module	Yes
Input - Input	Yes
Input voltage	
Nominal	24 VDC
Maximum	30 VDC
Input current at nominal voltage	Approx. 30 mA
Switching threshold	
Low	<5 V
High	>15 V
Switching delay at nominal input voltage	
Enable 1 $\rightarrow$ 0, PWM off	Max. 20.5 ms
Enable 0 $\rightarrow$ 1, ready for PWM	Max. 100 $\mu$ s
Modulation compared to ground potential	Max. $\pm 38$ V
OSSD signal connections <sup>16)</sup>	Permitted Max. test pulse length: 500 $\mu$ s
Variant	15-pin male TYCO connector <sup>3)</sup>
<b>Trigger inputs</b>	
Quantity	2
Circuit	Sink
Electrical isolation	
Input - Inverter module	No
Input - Input	No
Input voltage	
Nominal	24 VDC
Maximum	30 VDC
Switching threshold	
Low	<5 V
High	>15 V
Input current at nominal voltage	In preparation
Switching delay	
Rising edge	In preparation
Falling edge	In preparation
Modulation compared to ground potential	In preparation
Max. line length	30 m
Variant	M8 connector
Sensor/Actuator power supply	
Voltage	24 VDC
Summation current	Max. 250 mA <sup>17)</sup>
<b>Temperature sensor connection</b>	
Quantity	1
Resistance range	500 $\Omega$ to 5 k $\Omega$
<b>Support</b>	
Software	
ACP10	V2.35.1 and higher

Table 17: 8CVI155S1HCS0.01-1 - Technical data

## Technical data

Order number	8CVI155S1HCS0.01-1
<b>Electrical properties</b>	
Discharge capacitance	0.1 µF
<b>Operating conditions</b>	
Permissible mounting orientations	
Hanging vertically	Yes
Horizontal, face up	Yes
Standing horizontally	Yes
Installation elevation above sea level	
Nominal	0 to 500 m
Maximum <sup>18)</sup>	4000 m
Pollution degree per EN 61800-5-1	2 (non-conductive pollution)
Overvoltage category per EN 61800-5-1	III
Flow rate	
Minimum	3 l/min <sup>19)</sup>
Maximum	6 l/min <sup>19)</sup>
Pressure drop depending on flow volume	
3 l/min	Typ. 0.3 bar
6 l/min	Typ. 0.7 bar
Max. continuous pressure <sup>20)</sup>	5 bar
Max. permissible return temperature	60°C
Degree of protection per EN 60529	IP65 <sup>21)</sup>
<b>Ambient conditions</b>	
Temperature	
Operation	
Nominal	5 to 40°C <sup>22)</sup>
Maximum	60°C
Storage	-25 to 55°C
Transport	-25 to 70°C
Relative humidity	
Operation	5 to 85%, non-condensing
Storage	5 to 95%, non-condensing
Transport	Max. 95% at 40°C
<b>Mechanical properties</b>	
Dimensions <sup>23)</sup>	
Width	137 mm
Height	287.2 mm
Depth	131 mm
Weight	In preparation

Table 17: 8CVI155S1HCS0.01-1 - Technical data

- 1) Achievable safety classifications (safety integrity level, safety category, performance level) are documented in the user's manual (section "Safety technology").
- 2) Valid under the following conditions: 750 VDC DC bus voltage, 5 kHz switching frequency, 40°C ambient temperature, installation elevation <500 m above sea level, no derating due to cooling type.
- 3) It is important to note that the 15-pin male TYCO connector is designed for max. 20 mating cycles.
- 4) The power consumption  $P_{24V, Out}$  corresponds to the portion of the power that is output on the X31 connector on the module.
- 5) Valid under the following conditions: 750 VDC DC bus voltage. The temperature specifications refer to the ambient temperature.
- 6) Value for the nominal switching frequency.
- 7) B&R recommends operating the module at its nominal switching frequency. Operating the module at a higher switching frequency for application-specific reasons reduces the continuous current and increases CPU utilization.
- 8) If necessary, the stress of the motor isolation system can be reduced by an additional externally wired dv/dt choke. For example, the RWK 305 three-phase dv/dt choke from Schaffner ([www.schaffner.com](http://www.schaffner.com)) can be used. IMPORTANT: Even when using a dv/dt choke, it is necessary to ensure that an EMC-compatible, low inductance shield connection is used!
- 9) The module's electrical output frequency (SCTRL\_SPEED\_ACT \* MOTOR\_POLEPAIRS) is monitored to protect against dual use in accordance with Regulation (EC) 428/2009 | 3A225. If the electrical output frequency of the module exceeds the limit value of 598 Hz uninterrupted for more than 0.5 s, then the current movement is aborted and error 6060 is output ("Power unit: Limit speed exceeded").
- 10) During configuration, it is necessary to check if the minimum voltage can be maintained on the holding brake with the intended wiring. For the operating voltage range of the holding brake, see the user documentation for the motor being used.
- 11) Limited to 30 m when using hybrid cables.
- 12) An additional reserve of 12 mA exists for terminating resistors and limit switch inputs.
- 13) This value does not correspond to the encoder resolution that must be configured in Automation Studio (16384 \* number of encoder lines).
- 14) Limited by the encoder in practice.
- 15) The measurement system offered by Heidenhain with limit switch outputs LIDA 47x, LIDA 48x and LIF4x1 was tested for compatibility. In practice, the cable length is limited by the encoder.
- 16) Output signal switching device (OSSD) signals are used for monitoring signal lines for short circuits and cross faults.
- 17) The summation current corresponds to the current that is output on the X23A and X24A connectors on the module.
- 18) Continuous operation at an installation elevation of 500 m to 4,000 m above sea level is possible taking the specified reduction of continuous current into account. Requirements that go beyond this must be arranged with B&R.
- 19) Valid under the following conditions: Coolant = Tap water. Values vary depending on the coolant and/or connection fitting being used!
- 20) The requirements of the complete system (tubing, heat exchangers, recooling systems, etc.) as well as any necessary application-specific requirements must be taken into account.
- 21) The specified degree of protection is only met if all connectors on the module that are not being used are closed with suitable threaded caps or slot covers! Suitable threaded caps or slot covers are available as optional accessories (X67AC0M08, X67AC0M12, 8CXC000.0000-00). The module is delivered with IP20 protection.
- 22) The temperature of the module's mounting surface is not permitted to exceed 60°C.
- 23) The dimensions refer to the actual device dimensions. Additional spacing above and below the devices must be taken into account for mounting and connection.

### 4.1.2.9 Pinouts

#### Danger!

Before performing service work, disconnect the power supply and wait 5 minutes to ensure that the DC bus of the drive system has discharged. Observe regulations!

#### Warning!

Drive systems can carry high levels of electrical voltage. Never connect or disconnect the connector when voltage is present!

#### Information:

To satisfy UL/CSA requirements, components of B&R drive systems are only permitted to be wired with copper wires with a permitted wire temperature of at least 75°C.

#### 4.1.2.9.1 Overview

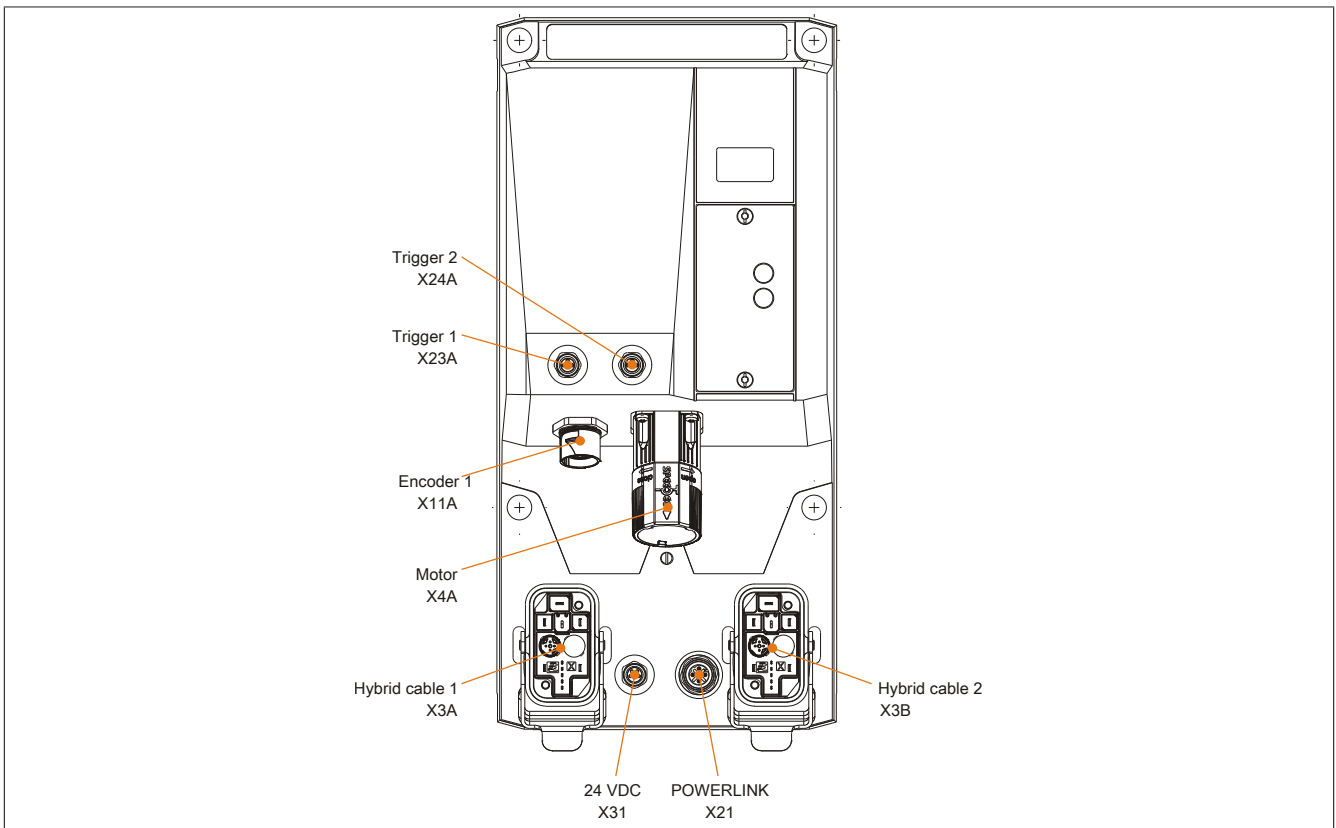

Figure 13: Pinout overview

#### 4.1.2.9.2 X4A (motor connection)

Figure	Pin	Name	Function
	1	U	Motor connection U
	2	PE	Protective ground conductor
	3	W	Motor connection W
	4	V	Motor connection V
	A	T+	Temperature +
	B	T-	Temperature -
	C	B+	Brake +
	D	B-	Brake -

Table 18: X4A connector - Pinout

### 4.1.2.9.3 X11A encoder connection

#### 4.1.2.9.3.1 SinCos (only 8CVIxxxS1HCS0.00-1)

Figure	Pin	Description	Function
	1	+5 V	Encoder power supply +5 V
	2	R	Reference pulse
	3	R\	Reference pulse inverted
	4	T+	Temperature sensor +
	5	T-	Temperature sensor -
	6	Sense-	Sense input 0 V
	7	COM	Encoder power supply 0 V
	8	A	Channel A
	9	A\	Channel A inverted
	10	B	Channel B
	11	B\	Channel B inverted
	12	---	---
	A	Limit+	Positive limit (L1)
	B	Limit-	Negative limit (L2)
C	Sense+	Sense input +5 V	

Table 19: X11A SinCos connector - Pinout

#### 4.1.2.9.3.2 EnDat 2.1 encoder connection (8CVI0xxE1HCS0.00-1 only)

Figure	Pin	Description	Function			
			SSI SinCos	EnDat 2.1	BiSS	SSI
	1	+5 V	Encoder supply +5 V			
	2	D	Data input			
	3	D\	Data input inverted			
	4	T+	Temperature sensor +			
	5	T-	Temperature sensor -			
	6	Sense-	Sense input 0 V			
	7	COM	Encoder supply 0 V			
	8	A	Channel A			---
	9	A\	Channel A inverted			---
	10	B	Channel B			---
	11	B\	Channel B inverted			---
	12	---				---
	A	T		Clock output		
	B	T\		Clock output inverted		
C	Sense+		Sense input +5 V			

Table 20: EnDat 2.1 connector X11A - Pinout

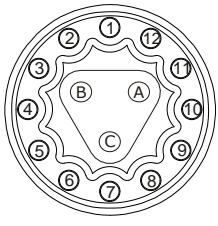
#### 4.1.2.9.3.3 HIPERFACE encoder connection (8CVI0xxH1HCS0.00-1 only)

Figure	Pin	Description	Function
	1	---	---
	2	D	Data input
	3	D\	Data input inverted
	4	Temp+	Temperature sensor +
	5	Temp-	Temperature sensor -
	6	---	---
	7	COM	Encoder supply 0 V
	8	SIN	Channel SIN
	9	REF A	REF SIN channel
	10	COS	Channel COS
	11	REF B	REF COS channel
	12	+10 V	Encoder supply +10 V
	A	---	---
	B	---	---
C	---	---	

Table 21: HIPERFACE connector X11A - Pinout

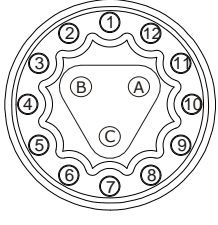
#### 4.1.2.9.4 X21 (POWERLINK)

Figure	Pin	Description	Function
	1	TXD	Transmit data
	2	RXD	Receive data
	3	TXD\	Transmit data inverted
	4	RXD\	Receive data inverted

Table 22: Connector X21x/X22x - Pinout

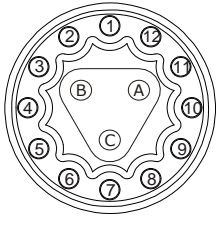
#### 4.1.2.9.5 X23A, X24A (trigger)

Figure	Pin	Description	Function
	1	+24 V	Sensor/actuator power supply 24 VDC <sup>1)</sup>
	3	GND	GND
	4	Trigger	Trigger input

Table 23: X23A, X24A connector - Pinout

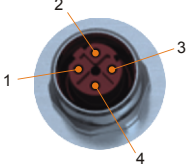
1) An external sensor/actuator power supply is not permitted.

#### 4.1.2.9.6 X31 (24 VDC routing)

Figure	Pin	Description	Function
	1	24 VDC I/O	24 VDC I/O power supply
	2	24 VDC I/O	24 VDC I/O power supply
	3	GND	24 VDC I/O power supply 0 V
	4	GND	24 VDC I/O power supply 0 V

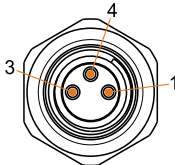
Table 24: Connector X31x - Pinout

#### 4.1.2.9.7 Ground connection (PE)

The protective ground conductor is attached via a cable lug to the M5 threaded bolt provided for this purpose, with a tightening torque of 3.5 Nm.

Figure	Pin	Name	Function					
	---	PE	Protective ground conductor					
	<table border="1"> <thead> <tr> <th>Terminal cross sections</th> <th>[mm<sup>2</sup>]</th> <th>AWG</th> </tr> </thead> <tbody> <tr> <td>Cable lug for M5 threaded bolt</td> <td>0.25 - 16</td> <td>23 - 5</td> </tr> </tbody> </table>			Terminal cross sections	[mm <sup>2</sup> ]	AWG	Cable lug for M5 threaded bolt	0.25 - 16
Terminal cross sections	[mm <sup>2</sup> ]	AWG						
Cable lug for M5 threaded bolt	0.25 - 16	23 - 5						

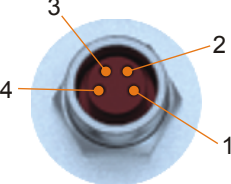
Table 25: Ground connection (PE)

#### 4.1.2.10 Setting the POWERLINK node number

The POWERLINK node number can be set using the two HEX rotary code switches located behind the black cover.

Remove cover:

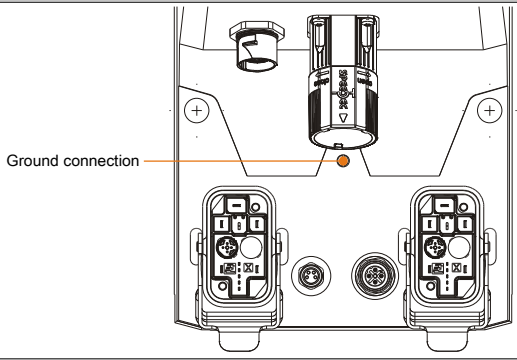
- Required tools: Size 10 Torx screwdriver
- Using the Torx screwdriver, unscrew the two fixing screws indicated (M3x6 mm Torx screws)
- Remove the cover

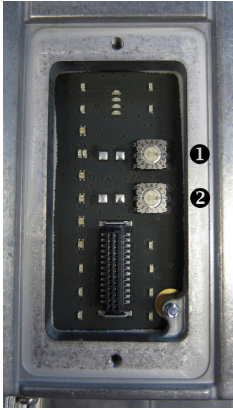
Images		Rotary code switch	POWERLINK node number
		1	16s position (high)
		2	1s position (low)
		<p>Changes to the POWERLINK node number are not applied until the ACOPOSmulti drive system is restarted.</p> <p><b>Information:</b></p> <p>In principle, node numbers between \$01 and \$FD are permitted. However, node numbers between \$F0 and \$FD are intended for future system expansions. To ensure compatibility, these node numbers should be avoided.</p> <p>Node numbers \$00, \$FE and \$FF are reserved and may therefore not be set.</p>	
Cover closed	Cover open		

Fit cover:

- Required tools: Size 10 Torx screwdriver
- Replace the cover on the module.
- Fasten the cover using the two fixing screws (M3x6 mm Torx screws).  
Tightening torque: 0.6 Nm

### 4.1.3 Accessories

#### 4.1.3.1 Cables

##### 4.1.3.1.1 General information

###### Assembling cables

Cables assembled by the user are equivalent to cables from 3rd-party manufacturers.

If cables from 3rd-party manufacturers are used, B&R is exempt from any liability and can make no guarantee for the respective characteristics or proper function of the B&R drive system. The user must ensure that the respective national regulations are observed.

#### Information:

**Pre-assembled cables from B&R are designed specifically for B&R drive systems and provide considerable support for the disturbance-free operation of B&R drive systems. Whenever possible, always use pre-assembled cables from B&R!**

##### 4.1.3.1.2 Motor cables

###### 4.1.3.1.2.1 General information

- Can be used in cable drag chains
- Assembled specifically for use with ACOPOSremote / ACOPOSmulti65 8CVI inverter modules and B&R servo motors with size 1 motor connectors
- speedtec - Innovative connector system for secure connections

###### 4.1.3.1.2.2 Order data

Order number	Short description	Figure
	<b>1.5 mm<sup>2</sup> motor cables</b>	
8CCM0001.11110-0	ACOPOSremote motor cable, length 1 m, 4x 1.5 mm <sup>2</sup> + 2x 2x 0.75 mm <sup>2</sup> , 8-pin female speedtec motor connector size 1, 8-pin male speedtec servo connector size 1, can be used in cable drag chains	
8CCM0002.11110-0	ACOPOSremote motor cable, length 2 m, 4x 1.5 mm <sup>2</sup> + 2x 2x 0.75 mm <sup>2</sup> , 8-pin female speedtec motor connector size 1, 8-pin male speedtec servo connector size 1, can be used in cable drag chains	
8CCM0003.11110-0	ACOPOSremote motor cable, length 3 m, 4x 1.5 mm <sup>2</sup> + 2x 2x 0.75 mm <sup>2</sup> , 8-pin female speedtec motor connector size 1, 8-pin male speedtec servo connector size 1, can be used in cable drag chains	
8CCM0004.11110-0	ACOPOSremote motor cable, length 4 m, 4x 1.5 mm <sup>2</sup> + 2x 2x 0.75 mm <sup>2</sup> , 8-pin female speedtec motor connector size 1, 8-pin male speedtec servo connector size 1, can be used in cable drag chains	
8CCM0005.11110-0	ACOPOSremote motor cable, length 5 m, 4x 1.5 mm <sup>2</sup> + 2x 2x 0.75 mm <sup>2</sup> , 8-pin female speedtec motor connector size 1, 8-pin male speedtec servo connector size 1, can be used in cable drag chains	

Table 26: 8CCM0001.11110-0, 8CCM0002.11110-0, 8CCM0003.11110-0, 8CCM0004.11110-0, 8CCM0005.11110-0 - Order data

4.1.3.1.2.3 Technical data

Order number	8CCM0001.11110-0	8CCM0002.11110-0	8CCM0003.11110-0	8CCM0004.11110-0	8CCM0005.11110-0
<b>General information</b>					
Cable cross section	4x 1.5 mm <sup>2</sup> + 2x 2x 0.75 mm <sup>2</sup>				
Durability	Oil resistance per VDE 0472 Part 803 as well as standard hydraulic oils				
Certification	UL AWM style 20234, 80°C, 1000 V, E63216 and CSA AWM I/II A/B, 90°C, 1000 V, FT2 LL46064				
Certifications					
CE	Yes				
UL	cULus E225616 Power conversion equipment				
EAC	Yes				
<b>Cable construction</b>					
Power lines					
Quantity	4				
Wire insulation	Special thermoplastic material				
Wire colors	Black, brown, blue, yellow/green				
Variant	Tinned copper stranded wire				
Cross section	1.5 mm <sup>2</sup>				
Shield	No				
Stranding	No				
Signal line					
Quantity	4				
Wire insulation	Special thermoplastic material				
Wire colors	White, white/red, white/blue, white/green				
Variant	Tinned copper stranded wire				
Cross section	0.75 mm <sup>2</sup>				
Shield	Individually shielded in pairs, tinned copper braiding, optical coverage >85% and foil shield				
Stranding	White with white/red and white/blue with white/green				
Cable stranding	With filler elements and foil shield				
Cable shield	Tinned copper braiding, optical coverage >85% and foil shield				
Outer jacket					
Material	PUR				
Color	Orange, similar to RAL 2003 flat				
Labeling	BERNECKER + RAINER 4x1,5+2x2x0,75 FLEX UL AWM STYLE 20234 80°C 1000 V E63216 CSA AWM I/II A/B 90°C 1000 V FT2 LL46064				
<b>Connector</b>					
Type	8-pin female speedtec connector				
Mating cycles	>50				
Contacts	8 (4 power and 4 signal contacts)				
Additional connectors	8-pin male speedtec coupling				
Degree of protection per EN 60529	IP67 when connected				
<b>Electrical properties</b>					
Test voltage					
Wire - Wire	3 kV				
Wire - Shield	3 kV				
Conductor resistance					
Power lines	≤0.01 Ω	≤0.03 Ω	≤0.04 Ω	≤0.06 Ω	≤0.07 Ω
Signal line	≤0.03 Ω	≤0.06 Ω	≤0.09 Ω	≤0.12 Ω	≤0.15 Ω
Insulation resistance	>200 GΩ	>100 GΩ	>66.67 GΩ	>50 GΩ	>40 GΩ
Current-carrying capacity per DIN VDE 0298 part 4, table 11					
Wall mounting	20 A				
Installed in conduit or cable duct	17.8 A				
Installed in cable tray	20.9 A				
<b>Ambient conditions</b>					
Temperature					
Moving	-10 to 80°C				
Static	-40 to 90°C				
<b>Mechanical properties</b>					
Dimensions					
Length	1 m	2 m	3 m	4 m	5 m
Diameter	12.8 mm ±0.4 mm				
Bend radius					
Single bend	>40 mm				
Moving	≥99 mm				
Drag chain data					
Acceleration	<60 m/s <sup>2</sup>				
Flex cycles <sup>1)</sup>	≥3000000				
Velocity	≤4 m/s				
Weight	0.5 kg	0.77 kg	1.03 kg	1.29 kg	1.5 kg

Table 27: 8CCM0001.11110-0, 8CCM0002.11110-0, 8CCM0003.11110-0, 8CCM0004.11110-0, 8CCM0005.11110-0 - Technical data

1) At an ambient temperature of 20°C and bend radius of 125 mm.

4.1.3.1.2.4 Cable construction

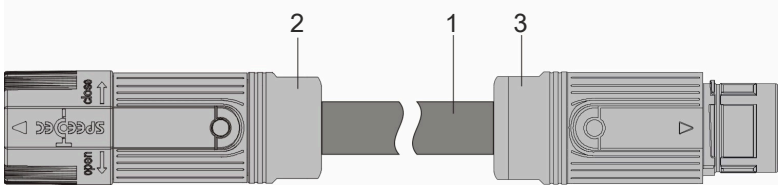

Pos.	Description	Note
1	Motor cable	4x 1.5 mm <sup>2</sup> + 2x 2x 0.75 mm <sup>2</sup>
2	8-pin female circular connector	
3	Circular connector, 8-pin male	

Table 28: Motor cables - Cable construction

4.1.3.1.2.5 Pinout

Female circular connector	Pin	Name	Function	Pin	Male circular connector
	1	U	Motor connection U	1	
	2	PE	Protective ground conductor	2	
	3	W	Motor connection W	3	
	4	V	Motor connection V	4	
	A	T+	Temperature +	A	
	B	T-	Temperature -	B	
	C	B+	Brake +	C	
	D	B-	Brake -	D	

Table 29: Motor cables - Pinout

4.1.3.1.2.6 Cable diagram

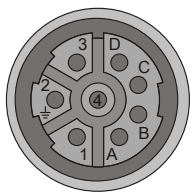
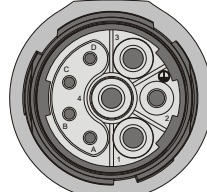
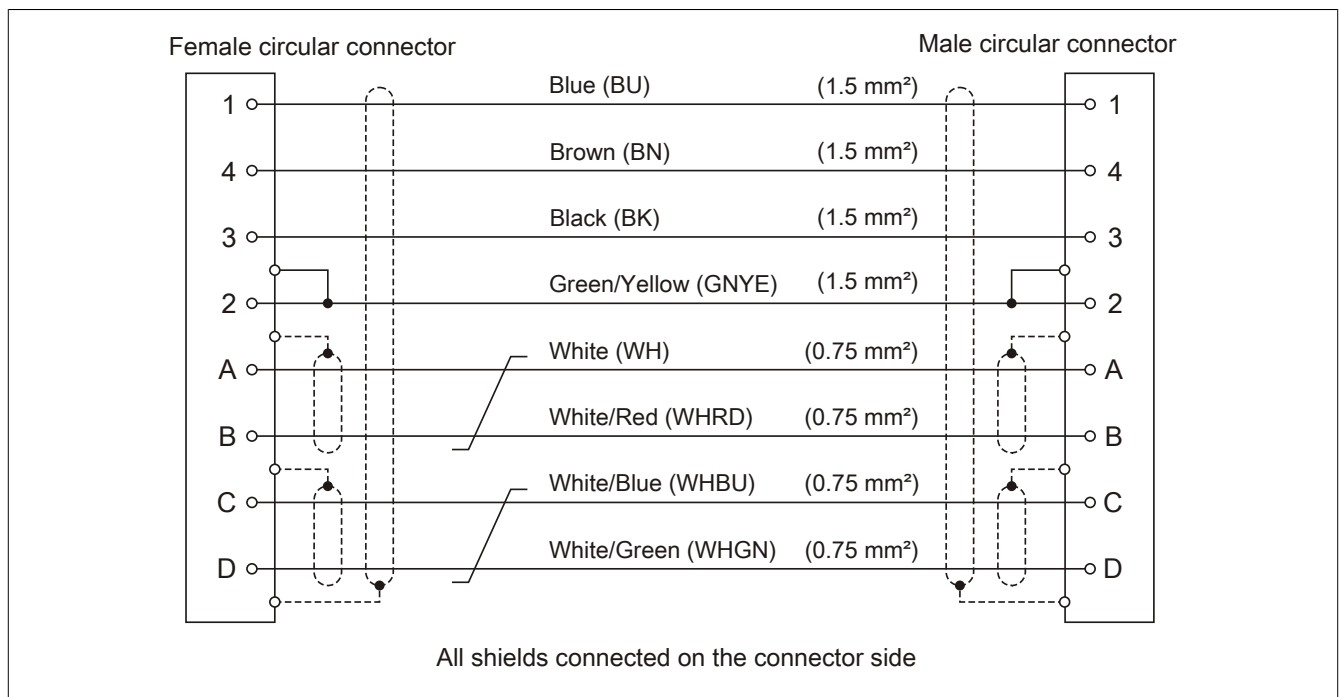

Figure 14: Motor cables - Cable diagram

### 4.1.3.1.3 SinCos cable

#### 4.1.3.1.3.1 General information

- Can be used in cable drag chains
- Assembled specifically for use with ACOPOSremote / ACOPOSmulti65 8CVI inverter modules and B&R servo motors with series 615 built-in connectors
- itec - Innovative connector system for secure connections

#### 4.1.3.1.3.2 Order data

Order number	Short description	Figure
	<b>SinCos cables</b>	
8CCS0001.11110-0	ACOPOSremote EnDat 2.1 cable, length 1 m, 10x 0.14 mm <sup>2</sup> + 2x 0.5 mm <sup>2</sup> , 12-pin female series 615 signal connector, 15-pin male series 615 signal connector, can be used in cable drag chains	
8CCS0002.11110-0	ACOPOSremote EnDat 2.1 cable, length 2 m, 10x 0.14 mm <sup>2</sup> + 2x 0.5 mm <sup>2</sup> , 12-pin female series 615 signal connector, 15-pin male series 615 signal connector, can be used in cable drag chains	
8CCS0003.11110-0	ACOPOSremote EnDat 2.1 cable, length 3 m, 10x 0.14 mm <sup>2</sup> + 2x 0.5 mm <sup>2</sup> , 12-pin female series 615 signal connector, 15-pin male series 615 signal connector, can be used in cable drag chains	
8CCS0004.11110-0	ACOPOSremote EnDat 2.1 cable, length 4 m, 10x 0.14 mm <sup>2</sup> + 2x 0.5 mm <sup>2</sup> , 12-pin female series 615 signal connector, 15-pin male series 615 signal connector, can be used in cable drag chains	
8CCS0005.11110-0	ACOPOSremote EnDat 2.1 cable, length 5 m, 10x 0.14 mm <sup>2</sup> + 2x 0.5 mm <sup>2</sup> , 12-pin female series 615 signal connector, 15-pin male series 615 signal connector, can be used in cable drag chains	

Table 30: 8CCS0001.11110-0, 8CCS0002.11110-0, 8CCS0003.11110-0, 8CCS0004.11110-0, 8CCS0005.11110-0 - Order data

#### 4.1.3.1.3.3 Technical data

Order number	8CCS0001.11110-0	8CCS0002.11110-0	8CCS0003.11110-0	8CCS0004.11110-0	8CCS0005.11110-0
<b>General information</b>					
Cable cross section	5x 2x 0.14 mm <sup>2</sup> + 1x 2x 0.50 mm <sup>2</sup>				
Durability	Oil resistance per VDE 0472 Part 803 as well as standard hydraulic oils <sup>1)</sup>				
Certification	UL AWM Style 20963, 80°C, 30 V, E63216 and CSA AWM I/II A/B, 90°C, 30 V, FT1 LL46064 <sup>1)</sup>				
Certifications					
CE	Yes				
UL	cULus E225616 Power conversion equipment				
<b>Cable construction</b>					
Supply lines					
Quantity	2				
Wire insulation	Special thermoplastic material				
Wire colors	White/Green, white/red				
Variant	Tinned copper stranded wire				
Cross section	0.5 mm <sup>2</sup>				
Shield	No				
Stranding	White/Red with white/green and filler elements				
Signal line					
Quantity	10				
Wire insulation	Special thermoplastic material				
Wire colors	Blue, brown, yellow, gray, green, pink, red, black, violet, white				
Variant	Tinned copper stranded wire				
Cross section	0.14 mm <sup>2</sup>				
Shield	No				
Stranding	Green with brown, gray with yellow, white with violet, black with red, pink with blue				
Cable stranding	With terminating foil shield				
Cable shield	Copper braiding, optical coverage >85% and foil shield				
Outer jacket					
Material	PUR				
Color	Green, similar to RAL 6018 flat				
Labeling	BERNECKER + RAINER 5x2x0,14+2x0,50 FLEX UL AWM STYLE 20963 80°C 30 V E63216 CSA AWM I/II A/B 90°C 30 V FT1 LL46064 <sup>1)</sup>				
<b>Connector</b>					
Type	12-pin female springtec connector				
Mating cycles	<500				
Contacts	12				

Table 31: 8CCS0001.11110-0, 8CCS0002.11110-0, 8CCS0003.11110-0, 8CCS0004.11110-0, 8CCS0005.11110-0 - Technical data

Order number	8CCS0001.11110-0	8CCS0002.11110-0	8CCS0003.11110-0	8CCS0004.11110-0	8CCS0005.11110-0
Additional connectors	15-pin male springtec connector Mating cycles: <500 Contacts: 15 Degree of protection per EN 60529: IP66/67 when connected				
Degree of protection per EN 60529	IP66/67 when connected				
<b>Electrical properties <sup>1)</sup></b>					
Operating voltage	≤30 V <sub>eff</sub>				
Test voltage					
Wire - Wire	1 kV				
Wire - Shield	0.8 kV				
Conductor resistance					
Supply lines	≤40 Ω/km				
Signal line	≤140 Ω/km				
Insulation resistance	>200 MΩ*km				
<b>Ambient conditions <sup>1)</sup></b>					
Temperature					
Moving	-20°C to +80°C				
Static	-20°C to +90°C				
<b>Mechanical properties <sup>1)</sup></b>					
Dimensions					
Length	1 m	2 m	3 m	4 m	5 m
Diameter	7.85 mm ±0.2 mm				
Bend radius					
Single bend	≥24 mm				
Moving	≥60 mm				
Drag chain data					
Acceleration	≤6 g				
Flex cycles <sup>2)</sup>	>3,000,000				
Velocity	≤4 m/s				
Weight	0.24 kg	0.32 kg	0.4 kg	0.48 kg	0.56 kg

Table 31: 8CCS0001.11110-0, 8CCS0002.11110-0, 8CCS0003.11110-0, 8CCS0004.11110-0, 8CCS0005.11110-0 - Technical data

- 1) Values refer to the raw cable being used.
- 2) At an ambient temperature of 20°C and bend radius of 65 mm.

#### 4.1.3.1.3.4 Cable construction

Pos.	Description	Note
1	Encoder cable	5x 2x 0.14 mm <sup>2</sup> + 2x 0.5 mm <sup>2</sup>
2	12-pin female circular connector	
3	Circular connector, 15-pin male	

Table 32: SinCos cables - Cable construction

4.1.3.1.3.5 Pinout

Connector	Pin	Description	Function	Pin	Connector
	1	+5 V	Encoder power supply +5 V	1	
	2	---	---	2	
	3	---	---	3	
	4	Sense +5 V	Sensor input +5 V	C	
	5	Sense 0 V	Sensor input 0 V	6	
	6	---	---	4	
	7	COM (1)	Encoder power supply 0 V	7	
	8	B	+ SIN	8	
	9	B\	- SIN	9	
	10	A	+ COS	10	
	11	A\	- COS	11	
	12	---	---	5	
---	---	---	12		
---	---	---	A		
---	---	---	B		

Table 33: SinCos cables - Pinout

4.1.3.1.3.6 Cable diagram

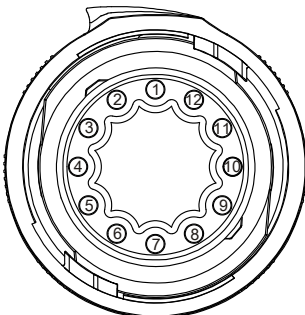
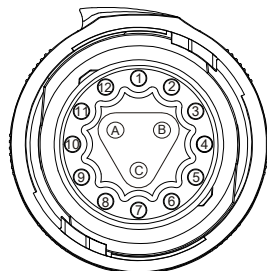
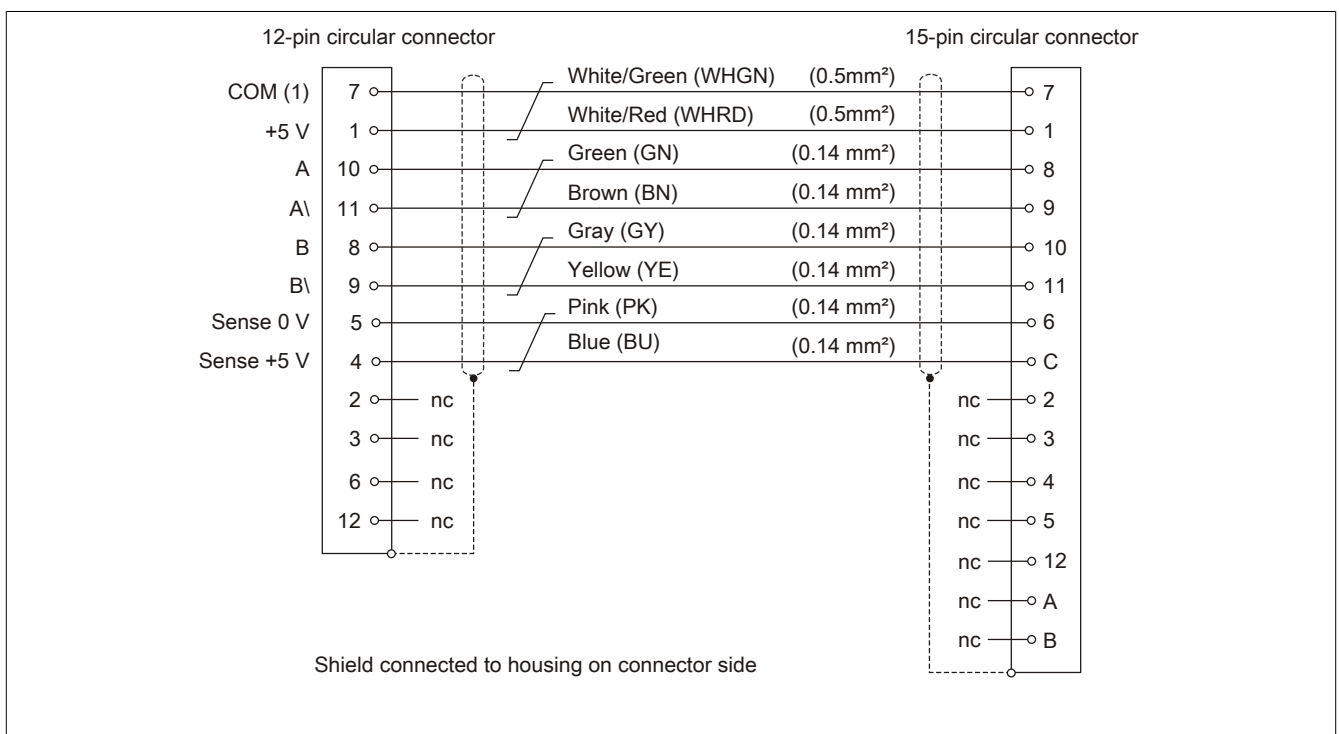

Figure 15: SinCos cables - Cable diagram

### 4.1.3.1.4 EnDat 2.1 cables

#### 4.1.3.1.4.1 General information

- Can be used in cable drag chains
- Assembled specifically for use with ACOPOSremote / ACOPOSmulti65 8CVI inverter modules and B&R servo motors

#### 4.1.3.1.4.2 Order data

Order number	Short description	Figure
	<b>EnDat 2.1 cables</b>	
8CCE0001.11210-0	ACOPOSremote EnDat 2.1 cable, length 1 m, 10x 0.14 mm <sup>2</sup> + 2x 0.5 mm <sup>2</sup> , 17-pin female speedtec motor connector, 15-pin male series 615 signal connector, can be used in cable drag chains	
8CCE0002.11210-0	ACOPOSremote EnDat 2.1 cable, length 2 m, 10x 0.14 mm <sup>2</sup> + 2x 0.5 mm <sup>2</sup> , 17-pin female speedtec motor connector, 15-pin male series 615 signal connector, can be used in cable drag chains	
8CCE0003.11210-0	ACOPOSremote EnDat 2.1 cable, length 3 m, 10x 0.14 mm <sup>2</sup> + 2x 0.5 mm <sup>2</sup> , 17-pin female speedtec motor connector, 15-pin male series 615 signal connector, can be used in cable drag chains	
8CCE0004.11210-0	ACOPOSremote EnDat 2.1 cable, length 4 m, 10x 0.14 mm <sup>2</sup> + 2x 0.5 mm <sup>2</sup> , 17-pin female speedtec motor connector, 15-pin male series 615 signal connector, can be used in cable drag chains	
8CCE0005.11210-0	ACOPOSremote EnDat 2.1 cable, length 5 m, 10x 0.14 mm <sup>2</sup> + 2x 0.5 mm <sup>2</sup> , 17-pin female speedtec motor connector, 15-pin male series 615 signal connector, can be used in cable drag chains	

Table 34: 8CCE0001.11210-0, 8CCE0002.11210-0, 8CCE0003.11210-0, 8CCE0004.11210-0, 8CCE0005.11210-0 - Order data

#### 4.1.3.1.4.3 Technical data

Order number	8CCE0001.11210-0	8CCE0002.11210-0	8CCE0003.11210-0	8CCE0004.11210-0	8CCE0005.11210-0
<b>General information</b>					
Cable cross section	5x 2x 0.14 mm <sup>2</sup> + 1x 2x 0.50 mm <sup>2</sup>				
Durability	Oil resistance per VDE 0472 Part 803 as well as standard hydraulic oils <sup>1)</sup>				
Certification	UL AWM Style 20963, 80°C, 30 V, E63216 and CSA AWM I/II A/B, 90°C, 30 V, FT1 LL46064 <sup>1)</sup>				
Certifications					
CE	Yes				
UL	cULus E225616 Power conversion equipment				
<b>Cable construction</b>					
Supply lines					
Quantity	2				
Wire insulation	Special thermoplastic material				
Wire colors	White/Green, white/red				
Variant	Tinned copper stranded wire				
Cross section	0.5 mm <sup>2</sup>				
Shield	No				
Stranding	White/Red with white/green and filler elements				
Signal line					
Quantity	10				
Wire insulation	Special thermoplastic material				
Wire colors	Blue, brown, yellow, gray, green, pink, red, black, violet, white				
Variant	Tinned copper stranded wire				
Cross section	0.14 mm <sup>2</sup>				
Shield	No				
Stranding	Green with brown, gray with yellow, white with violet, black with red, pink with blue				
Cable stranding	With terminating foil shield				
Cable shield	Copper braiding, optical coverage >85% and foil shield				
Outer jacket					
Material	PUR				
Color	Green, similar to RAL 6018 flat				
Labeling	BERNECKER + RAINER 5x2x0,14+2x0,50 FLEX UL AWM STYLE 20963 80°C 30 V E63216 CSA AWM I/II A/B 90°C 30 V FT1 LL46064 <sup>1)</sup>				
<b>Connector</b>					
Type	17-pin female speedtec motor connector				
Mating cycles	<500				
Contacts	17				

Table 35: 8CCE0001.11210-0, 8CCE0002.11210-0, 8CCE0003.11210-0, 8CCE0004.11210-0, 8CCE0005.11210-0 - Technical data

## Technical data

Order number	8CCE0001.11210-0	8CCE0002.11210-0	8CCE0003.11210-0	8CCE0004.11210-0	8CCE0005.11210-0
Additional connectors	15-pin male springtec servo connector Mating cycles: <500 Contacts: 15 Degree of protection per EN 60529: IP66/67 when connected				
Degree of protection per EN 60529	IP66/67 when connected				
<b>Electrical properties <sup>1)</sup></b>					
Operating voltage	≤30 V <sub>eff</sub>				
Test voltage					
Wire - Wire	1 kV				
Wire - Shield	0.8 kV				
Conductor resistance					
Supply lines	≤40 Ω/km				
Signal line	≤140 Ω/km				
Insulation resistance	>200 MΩ*km				
<b>Ambient conditions <sup>1)</sup></b>					
Temperature					
Moving	-20°C to +80°C				
Static	-20°C to +90°C				
<b>Mechanical properties <sup>1)</sup></b>					
Dimensions					
Length	1 m	2 m	3 m	4 m	5 m
Diameter	7.85 mm ±0.2 mm				
Bend radius					
Single bend	≥24 mm				
Moving	≥60 mm				
Drag chain data					
Acceleration	≤6 g				
Flex cycles <sup>2)</sup>	>3,000,000				
Velocity	≤4 m/s				
Weight	0.08 kg	0.28 kg	0.24 kg	0.32 kg	0.4 kg

Table 35: 8CCE0001.11210-0, 8CCE0002.11210-0, 8CCE0003.11210-0, 8CCE0004.11210-0, 8CCE0005.11210-0 - Technical data

- 1) Values refer to the raw cable being used.  
2) At an ambient temperature of 20°C and bend radius of 65 mm.

### 4.1.3.1.4.4 Wiring

#### Cable construction

Pos.	Description	Note
1	Encoder line	5x 2x 0.14 mm <sup>2</sup> + 2x 0.50 mm <sup>2</sup>
2	17-pin motor connector, female	
3	15-pin servo connector, male	

Table 36: EnDat 2.1 cables - Cable construction

**Pinout**

Connector	Pin	Description	Function	Pin	Connector
	1	Sense +5 V	Sense input +5 V	C	
	2	---	---	4	
	3	---	---	5	
	4	Sense COM	Sense input 0 V	6	
	5	---	---	12	
	6	---	---		
	7	+5 V Out	Encoder power supply +5 V	1	
	8	T	Clock output	A	
	9	T\	Clock output inverted	B	
	10	COM	Encoder power supply 0 V	7	
	11	---	---		
	12	B	Channel B	10	
	13	B\	Channel B inverted	11	
	14	D	Data input	2	
	15	A	Channel A	8	
	16	A\	Channel A inverted	9	
	17	D\	Data inverted	3	

Table 37: EnDat 2.1 cables - Pinout

**Cable diagram**

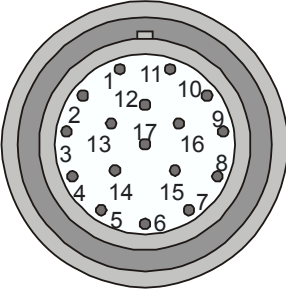
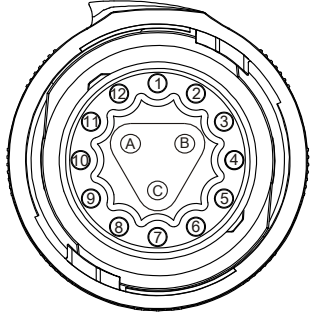
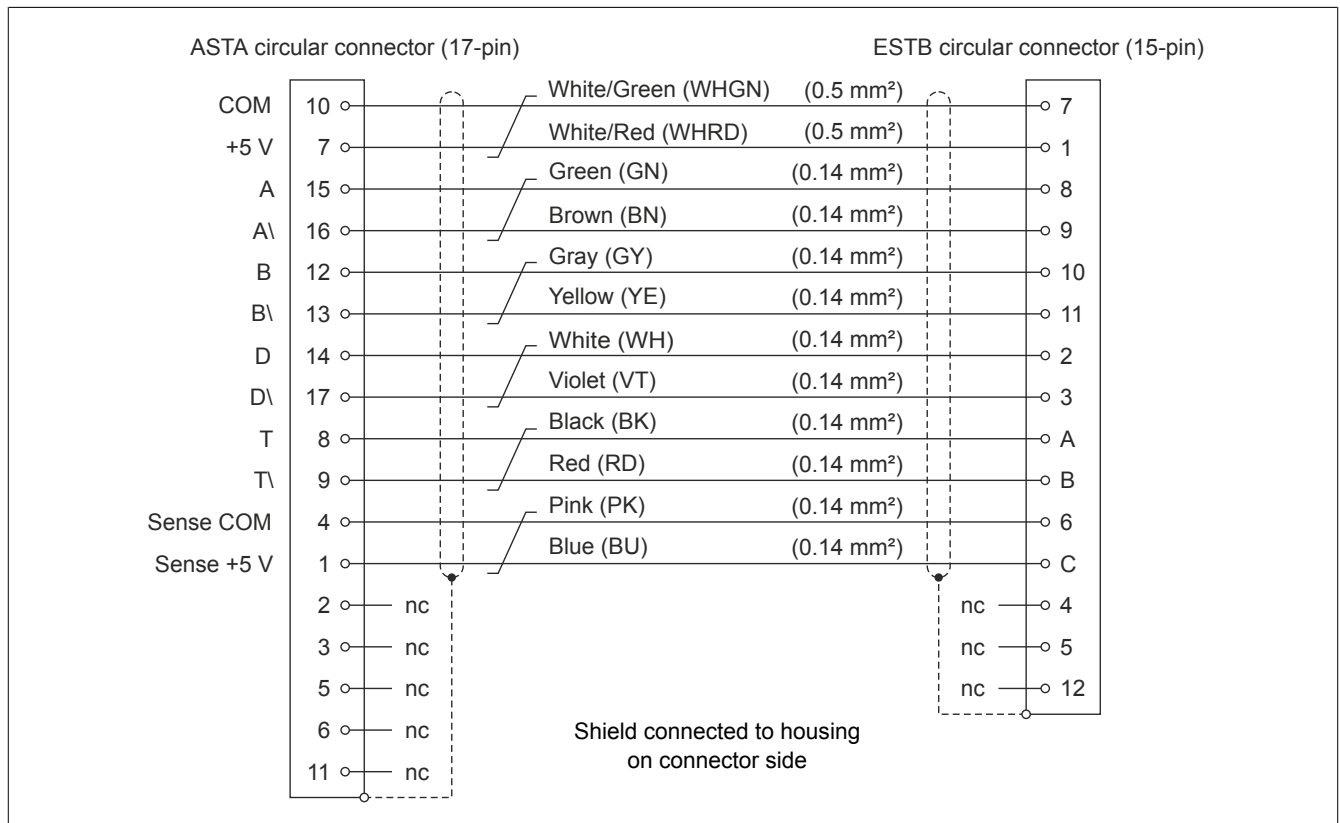

Figure 16: EnDat 2.1 cables - Cable diagram

### 4.1.3.2 Screw sets

#### 4.1.3.2.1 Order data

Order number	Short description	Figure
<b>Accessory sets</b>		
8CXM000.0000-00	ACOPOSremote accessory set: 4x hex socket screw M6x80mm for 8CVI inverter modules	
8CXM000.0002-00	ACOPOSremote accessory set: 20x hex socket screw M6x80mm for 8CVI inverter modules	
8CXM000.0005-00	ACOPOSremote accessory set: 52x hex socket screw M6x80mm for 8CVI inverter modules	
8CXM000.000A-00	ACOPOSremote accessory set: 100x hex socket screw M6x80mm for 8CVI inverter modules	

Table 38: 8CXM000.0000-00, 8CXM000.0002-00, 8CXM000.0005-00, 8CXM000.000A-00 - Order data

#### 4.1.3.2.2 Technical data

Order number	8CXM000.0000-00	8CXM000.0002-00	8CXM000.0005-00	8CXM000.000A-00
<b>General information</b>				
Short description	Accessory set for 8CVI inverter modules: 4x hex socket screw M6x80mm	Accessory set for 8CVI inverter modules: 20x hex socket screw M6x80mm	Accessory set for 8CVI inverter modules: 52x hex socket screw M6x80mm	Accessory set for 8CVI inverter modules: 100x hex socket screw M6x80mm
Certifications	CE			
Yes				
<b>Mechanical properties</b>				
Weight	77 g	382 g	1011 g	1886 g

Table 39: 8CXM000.0000-00, 8CXM000.0002-00, 8CXM000.0005-00, 8CXM000.000A-00 - Technical data

## 4.2 8CVE connection box

### 4.2.1 Overview

#### Connection boxes

Order number	Short description	Page
8CVE28000HC00.00-1	ACOPOSremote/ACOPOSmotor connection box, AS, IP65, cold plate mounting, 4x connection for hybrid cable, 2x 24 VDC Out	84

#### Accessory set

Order number	Short description	Page
8CXC001.0000-00	ACOPOSremote accessory set: 2x bridge, 2-pin, fully isolated, pitch 10 mm	96

#### Screw sets

Order number	Short description	Page
8CXM000.0000-00	ACOPOSremote accessory set: 4x hex socket screw M6x80mm for 8CVI inverter modules	82
8CXM000.0002-00	ACOPOSremote accessory set: 20x hex socket screw M6x80mm for 8CVI inverter modules	82
8CXM000.0005-00	ACOPOSremote accessory set: 52x hex socket screw M6x80mm for 8CVI inverter modules	82
8CXM000.000A-00	ACOPOSremote accessory set: 100x hex socket screw M6x80mm for 8CVI inverter modules	82

#### Fuse sets

Order number	Short description	Page
8CXS000.0000-00	ACOPOSremote fuse set: 8x fuse 10 x 38 mm, 20 A, fast-acting	97
8CXS001.0000-00	ACOPOSremote fuse set: 4x flat fuse 7.5 A, fast-acting	97
8CXS001.0002-00	ACOPOSremote fuse set: 20x flat fuse 7.5 A, fast-acting	97
8CXS001.0005-00	ACOPOSremote fuse set: 52x flat fuse 7.5 A, fast-acting	97
8CXS001.000A-00	ACOPOSremote fuse set: 100x flat fuse 7.5 A, fast-acting	97
8CXS002.0000-00	ACOPOSremote fuse set: 4x blade fuse 15 A, fast-acting	98
8CXS002.0002-00	ACOPOSremote fuse set: 20x blade fuse 15 A, fast-acting	98
8CXS002.0005-00	ACOPOSremote fuse set: 52x blade fuse 15 A, fast-acting	98
8CXS002.000A-00	ACOPOSremote fuse set: 100x blade fuse 15 A, fast-acting	98

### General accessories

#### Hybrid cables

Order number	Short description	Page
8CCH0005.11110-1	Hybrid cable, length 5 m, 2x 2x 0.34 mm <sup>2</sup> + 4x 0.75 mm <sup>2</sup> + 5x 2.5 mm <sup>2</sup> , 2x 15-pin female TYCO connector, can be used in cable drag chains	362
8CCH0007.11110-1	Hybrid cable, length 7 m, 2x 2x 0.34 mm <sup>2</sup> + 4x 0.75 mm <sup>2</sup> + 5x 2.5 mm <sup>2</sup> , 2x 15-pin female TYCO connector, can be used in cable drag chains	362

Order number	Short description	Page
8CCH0010.11110-1	Hybrid cable, length 10 m, 2x 2x 0.34 mm <sup>2</sup> + 4x 0.75 mm <sup>2</sup> + 5x 2.5 mm <sup>2</sup> , 2x 15-pin female TYCO connector, can be used in cable drag chains	362
8CCH0015.11110-1	Hybrid cable, length 15 m, 2x 2x 0.34 mm <sup>2</sup> + 4x 0.75 mm <sup>2</sup> + 5x 2.5 mm <sup>2</sup> , 2x 15-pin female TYCO connector, can be used in cable drag chains	362
8CCH0020.11110-1	Hybrid cable, length 20 m, 2x 2x 0.34 mm <sup>2</sup> + 4x 0.75 mm <sup>2</sup> + 5x 2.5 mm <sup>2</sup> , 2x 15-pin female TYCO connector, can be used in cable drag chains	362

Order number	Short description	Page
8CCH0001.11130-1	Hybrid cable, length 1 m, 2x 2x 0.34 mm <sup>2</sup> + 4x 0.75 mm <sup>2</sup> + 5x 2.5 mm <sup>2</sup> , 2x 15-pin female TYCO connector, 1x connector insert rotated 180°, can be used in cable drag chains	364
8CCH0002.11130-1	Hybrid cable, length 2 m, 2x 2x 0.34 mm <sup>2</sup> + 4x 0.75 mm <sup>2</sup> + 5x 2.5 mm <sup>2</sup> , 2x 15-pin female TYCO connector, 1x connector insert rotated 180°, can be used in cable drag chains	364
8CCH0003.11130-1	Hybrid cable, length 3 m, 2x 2x 0.34 mm <sup>2</sup> + 4x 0.75 mm <sup>2</sup> + 5x 2.5 mm <sup>2</sup> , 2x 15-pin female TYCO connector, 1x connector insert rotated 180°, can be used in cable drag chains	364
8CCH0004.11130-1	Hybrid cable, length 4 m, 2x 2x 0.34 mm <sup>2</sup> + 4x 0.75 mm <sup>2</sup> + 5x 2.5 mm <sup>2</sup> , 2x 15-pin female TYCO connector, 1x connector insert rotated 180°, can be used in cable drag chains	364
8CCH0005.11130-1	Hybrid cable, length 5 m, 2x 2x 0.34 mm <sup>2</sup> + 4x 0.75 mm <sup>2</sup> + 5x 2.5 mm <sup>2</sup> , 2x 15-pin female TYCO connector, 1x connector insert rotated 180°, can be used in cable drag chains	364

Order number	Short description	Page
8CCH0001.11230-1	Hybrid cable, length 1 m, 2x 2x 0.34 mm <sup>2</sup> + 4x 0.75 mm <sup>2</sup> + 5x 2.5 mm <sup>2</sup> , 2x 15-pin female TYCO connector, connector insert rotated 180°, can be used in cable drag chains	367
8CCH0002.11230-1	Hybrid cable, length 2 m, 2x 2x 0.34 mm <sup>2</sup> + 4x 0.75 mm <sup>2</sup> + 5x 2.5 mm <sup>2</sup> , 2x 15-pin female TYCO connector, connector insert rotated 180°, can be used in cable drag chains	367
8CCH0003.11230-1	Hybrid cable, length 3 m, 2x 2x 0.34 mm <sup>2</sup> + 4x 0.75 mm <sup>2</sup> + 5x 2.5 mm <sup>2</sup> , 2x 15-pin female TYCO connector, connector insert rotated 180°, can be used in cable drag chains	367
8CCH0004.11230-1	Hybrid cable, length 4 m, 2x 2x 0.34 mm <sup>2</sup> + 4x 0.75 mm <sup>2</sup> + 5x 2.5 mm <sup>2</sup> , 2x 15-pin female TYCO connector, connector insert rotated 180°, can be used in cable drag chains	367
8CCH0005.11230-1	Hybrid cable, length 5 m, 2x 2x 0.34 mm <sup>2</sup> + 4x 0.75 mm <sup>2</sup> + 5x 2.5 mm <sup>2</sup> , 2x 15-pin female TYCO connector, connector insert rotated 180°, can be used in cable drag chains	367

Order number	Short description	Page
8CCH0005.11220-1	Hybrid cable for connecting 8BVE to 8CVI or 8DI, length 5 m, 2x 2x 0.34 mm <sup>2</sup> + 4x 0.75 mm <sup>2</sup> + 5x 2.5 mm <sup>2</sup> , 1x 15-pin female TYCO connector, connector insert rotated 180°, can be used in cable drag chains	370
8CCH0007.11220-1	Hybrid cable for connecting 8BVE to 8CVI or 8DI, length 7 m, 2x 2x 0.34 mm <sup>2</sup> + 4x 0.75 mm <sup>2</sup> + 5x 2.5 mm <sup>2</sup> , 1x 15-pin female TYCO connector, connector insert rotated 180°, can be used in cable drag chains	370
8CCH0010.11220-1	Hybrid cable for connecting 8BVE to 8CVI or 8DI, length 10 m, 2x 2x 0.34 mm <sup>2</sup> + 4x 0.75 mm <sup>2</sup> + 5x 2.5 mm <sup>2</sup> , 1x 15-pin female TYCO connector, connector insert rotated 180°, can be used in cable drag chains	370
8CCH0015.11220-1	Hybrid cable for connecting 8BVE to 8CVI or 8DI, length 15 m, 2x 2x 0.34 mm <sup>2</sup> + 4x 0.75 mm <sup>2</sup> + 5x 2.5 mm <sup>2</sup> , 1x 15-pin female TYCO connector, connector insert rotated 180°, can be used in cable drag chains	370
8CCH0020.11220-1	Hybrid cable for connecting 8BVE to 8CVI or 8DI, length 20 m, 2x 2x 0.34 mm <sup>2</sup> + 4x 0.75 mm <sup>2</sup> + 5x 2.5 mm <sup>2</sup> , 1x 15-pin female TYCO connector, connector insert rotated 180°, can be used in cable drag chains	370

### Slot covers

Order number	Short description	Page
8CXC000.0000-00	Accessory set: 1x slot cover for hybrid connector	377
X67AC0M08	X67 M8 threaded caps, 50 pcs.	378
X67AC0M12	X67 M12 threaded caps, 50 pcs.	378

## 4.2.2 Connection boxes

### 4.2.2.1 8CVE28000HC00.00-1

#### 4.2.2.1.1 Order data

Order number	Short description	Figure
	<b>Connection boxes</b>	
8CVE28000HC00.00-1	ACOPOSremote/ACOPOSmotor connection box, AS, IP65, cold plate mounting, 4x connection for hybrid cable, 2x 24 VDC Out	
	<b>Required accessories</b>	
	<b>Fuse sets</b>	
8CXS000.0000-00	ACOPOSremote fuse set: 8x fuse 10 x 38 mm, 20 A, fast-acting	
8CXS002.0000-00	ACOPOSremote fuse set: 4x blade fuse 15 A, fast-acting	
	<b>Optional accessories</b>	
	<b>Accessory sets</b>	
8CXC000.0000-00	Accessory set: 1x slot cover for hybrid connector	
8CXC001.0000-00	ACOPOSremote accessory set: 2x bridge, 2-pin, fully isolated, pitch 10 mm	
8CXC001.0002-00	ACOPOSremote accessory set: 20x bridge, 2-pin, fully isolated, pitch 10 mm	
8CXC001.0005-00	ACOPOSremote accessory set: 50x bridge, 2-pin, fully isolated, pitch 10 mm	
8CXC001.000A-00	ACOPOSremote accessory set: 100x bridge, 2-pin, fully isolated, pitch 10 mm	
8CXD000.0000-00	ACOPOSremote accessory set: 1x dry cartridge M36x1.5 for 8CVE connection box	
8CXM001.0000-00	ACOPOSremote accessory set: 4x M6x25 mm hex socket head screw for 8CVE connection boxes	
8CXM001.0002-00	ACOPOSremote accessory set: 20x M6x25 mm hex socket head screw for 8CVE connection boxes	
8CXM001.0005-00	ACOPOSremote accessory set: 52x M6x25 mm hex socket head screw for 8CVE connection boxes	
8CXM001.000A-00	ACOPOSremote accessory set: 100x M6x25 mm hex socket head screw for 8CVE connection boxes	
	<b>Fuse sets</b>	
8CXS001.0000-00	ACOPOSremote fuse set: 4x blade fuse 7.5 A, fast-acting	
8CXS001.0002-00	ACOPOSremote fuse set: 20x blade fuse 7.5 A, fast-acting	
8CXS001.0005-00	ACOPOSremote fuse set: 52x blade fuse 7.5 A, fast-acting	
8CXS001.000A-00	ACOPOSremote fuse set: 100x blade fuse 7.5 A, fast-acting	
8CXS002.0002-00	ACOPOSremote fuse set: 20x blade fuse 15 A, fast-acting	
8CXS002.0005-00	ACOPOSremote fuse set: 52x blade fuse 15 A, fast-acting	
8CXS002.000A-00	ACOPOSremote fuse set: 100x blade fuse 15 A, fast-acting	
	<b>Hybrid cables</b>	
8CCH0003.11110-1	Hybrid cable, length 3 m, 2x 2x 0.34 mm <sup>2</sup> + 4x 0.75 mm <sup>2</sup> + 5x 2.5 mm <sup>2</sup> , 2x 15-pin female TYCO connector, can be used in cable drag chains	
8CCH0003.11130-1	Hybrid cable, length 3 m, 2x 2x 0.34 mm <sup>2</sup> + 4x 0.75 mm <sup>2</sup> + 5x 2.5 mm <sup>2</sup> , 2x 15-pin female TYCO connector, 1x connector insert rotated 180°, can be used in cable drag chains	
8CCH0005.11110-1	Hybrid cable, length 5 m, 2x 2x 0.34 mm <sup>2</sup> + 4x 0.75 mm <sup>2</sup> + 5x 2.5 mm <sup>2</sup> , 2x 15-pin female TYCO connector, can be used in cable drag chains	
8CCH0010.11110-1	Hybrid cable, length 10 m, 2x 2x 0.34 mm <sup>2</sup> + 4x 0.75 mm <sup>2</sup> + 5x 2.5 mm <sup>2</sup> , 2x 15-pin female TYCO connector, can be used in cable drag chains	
8CCH0015.11110-1	Hybrid cable, length 15 m, 2x 2x 0.34 mm <sup>2</sup> + 4x 0.75 mm <sup>2</sup> + 5x 2.5 mm <sup>2</sup> , 2x 15-pin female TYCO connector, can be used in cable drag chains	
8CCH0020.11110-1	Hybrid cable, length 20 m, 2x 2x 0.34 mm <sup>2</sup> + 4x 0.75 mm <sup>2</sup> + 5x 2.5 mm <sup>2</sup> , 2x 15-pin female TYCO connector, can be used in cable drag chains	
	<b>Threaded caps</b>	
X67AC0M08	X67 M8 threaded caps, 50 pcs.	
X67AC0M12	X67 M12 threaded caps, 50 pcs.	

Table 40: 8CVE28000HC00.00-1 - Order data

#### 4.2.2.1.2 Technical data

Order number	8CVE28000HC00.00-1
<b>General information</b>	
B&R ID code	0xB41D
Status indicators	Safety status, interface status

Table 41: 8CVE28000HC00.00-1 - Technical data

Order number	8CVE28000HC00.00-1
Support	
Dynamic node allocation (DNA)	Yes
Cooling and mounting type	Cold plate mounting
Certifications	
CE	Yes
Functional safety <sup>1)</sup>	Yes
UL	cULus E225616 Power conversion equipment
<b>DC bus connection <sup>2)</sup></b>	
Voltage	
Nominal	750 VDC
Variant	
DC+, DC-, PE	Cage clamp terminal block
Shield connection	Yes (via cable gland)
Terminal connection cross sections	
Flexible and fine-stranded wires	
With wire end sleeves	0.25 to 10 mm <sup>2</sup>
Approbation data	
UL/C-UL-US	24 to 8
CSA	24 to 8
Terminal cross sections (cable diameter)	14 to 21 mm (M32 cable grommet)
Max. line length	30 m
<b>24 VDC power supply <sup>2)</sup></b>	
Quantity	2
Input voltage	24 VDC -25% / +20%
Max. power consumption <sup>3)</sup>	In preparation
Variant	
24 VDC, COM, PE	Cage clamp terminal block
Shield connection	No
Terminal connection cross sections	
Flexible and fine-stranded wires	
With wire end sleeves	0.25 to 10 mm <sup>2</sup>
Approbation data	
UL/C-UL-US	24 to 8
CSA	24 to 8
Terminal cross sections (cable diameter)	14 to 21 mm (M32 cable grommet)
Max. line length	30 m
<b>Hybrid cable outlets</b>	
Quantity	4 (each with DC bus, 24 VDC, 2x enable, POWERLINK)
DC+ and DC- fuse protection	
Type <sup>4)</sup>	Melting fuse conforming to UL/CSA, ø 10 x 38 mm
Tripping characteristic	Fast-acting
Rated current of fuse depending on ambient temperature	
40°C	In preparation
60°C	20 A
24 VDC fuse protection	
Type	Blade fuses conforming to UL/CSA
Tripping characteristic	Fast-acting
Rated current of fuse depending on ambient temperature	
40°C	In preparation
60°C	15 A
Continuous power depending on rated current of fuse <sup>5)</sup>	
DC+ and DC-	
20 A	10.1 kW
24 VDC	
15 A	240 W
Continuous current depending on rated current of fuse	
DC+ and DC-	
20 A	13.5 A <sub>eff</sub>
24 VDC	
15 A	10.1 A
Continuous current of enable outputs	Max. 500 mA
Reduction of continuous power depending on installation elevation	
Starting at 500 m above sea level	10% per 1,000 m

Table 41: 8CVE28000HC00.00-1 - Technical data

## Technical data

Order number	8CVE28000HC00.00-1
Power dissipation with continuous power	
DC+ and DC-	
20 A	In preparation
24 VDC	
15 A	In preparation
Protective measures	
Overload protection	
DC+ and DC-	No (overload status can be retrieved via fieldbus) <sup>6)</sup>
24 VDC	No (overload status can be retrieved via fieldbus) <sup>6)</sup>
Short-circuit and ground fault protection	
DC+ and DC-	Yes
24 VDC	Yes
Max. line length	30 m
Variant	15-pin male TYCO connector <sup>7)</sup>
<b>24 VDC output</b>	
Quantity	2
Output voltage	Depends on the 24 VDC power supply
Continuous current	Max. 8 A (max. 4 A per pin)
Fuse protection per pin	
Type	Blade fuses conforming to UL/CSA
Tripping characteristic	Fast-acting
Rated current of fuse depending on ambient temperature	
40°C	5 A
60°C	7.5 A
Protective measures	
Overload-proof	No (overload status can be retrieved via fieldbus) <sup>6)</sup>
Short-circuit proof	Yes
Variant	
24 VDC, COM	Female M8 connector
<b>Fieldbus</b>	
Type	POWERLINK (V1/V2) 100BASE-T (ANSI/IEE 802.3)
Variant	1x internal 4-port hub, 1x internal 5-port hub; 4x 19-pin hybrid connector, 4x M12 female connector
Line length	Max. 100 m between two stations (segment length) <sup>8)</sup>
Transfer rate	100 Mbit/s
<b>Enable inputs</b>	
Quantity	2
Input voltage	
Nominal	24 VDC
Maximum	30 VDC
Permissible input current	Max. 2 A
Variant	Cage clamp terminal block
Terminal connection cross sections	
Flexible and fine-stranded wires	
With plastic wire end sleeves	0.25 to 1.5 mm <sup>2</sup>
Approbation data	
UL/C-UL-US	26 to 12
CSA	-
Terminal cross sections (cable diameter)	5 to 9 mm (M16 cable grommet)
Max. line length	30 m
<b>Operating conditions</b>	
Permissible mounting orientations	
Hanging vertically	Yes
Horizontal, face up	Yes
Standing horizontally	Yes
Installation elevation above sea level	
Nominal	0 to 500 m
Maximum <sup>9)</sup>	4000 m
Pollution degree per EN 61800-5-1	2 (non-conductive pollution)
Overvoltage category per EN 61800-5-1	III
Degree of protection per EN 60529	IP65 <sup>10)</sup>
<b>Ambient conditions</b>	
Temperature	
Operation	
Nominal	5 to 40°C <sup>11)</sup>
Maximum <sup>12)</sup>	60°C
Storage	-25 to 55°C
Transport	-25 to 70°C
Relative humidity	
Operation	5 to 85%, non-condensing
Storage	5 to 95%, non-condensing
Transport	Max. 95% at 40°C

Table 41: 8CVE28000HC00.00-1 - Technical data

Order number	8CVE28000HC00.00-1
<b>Mechanical properties</b>	
Dimensions <sup>13)</sup>	
Width	293 mm
Height	328 mm
Depth	80 mm
Weight	7 kg

Table 41: 8CVE28000HC00.00-1 - Technical data

- 1) Achievable safety classifications (safety integrity level, safety category, performance level) are documented in the user's manual (section "Safety technology").
- 2) Caution! Power for 8CVE remote connection boxes is only permitted to be supplied by an ACOPOSmulti drive system (8BVE expansion module)!
- 3) Power consumption refers to the 24 VDC2 input since this supplies the module.
- 4) For a cable with 15 A rated current, KLKD020 fuses from Littelfuse must be used.
- 5) The continuous power and continuous current are valid under the following conditions: 750 VDC nominal DC bus voltage, 40°C ambient temperature, installation elevation <500 m above sea level. The values specified take into account a reserve of 48% (recommended by fuse manufacturer) of the rated current (for a max. ambient temperature of 60°C).
- 6) In preparation.
- 7) It is important to note that the 15-pin male TYCO connector is designed for max. 20 mating cycles.
- 8) Limited to 30 m when using hybrid cables.
- 9) Continuous operation at an installation elevation of 500 m to 4,000 m above sea level is possible taking the specified reduction of continuous current into account. Requirements that go beyond this must be arranged with B&R.
- 10) The specified degree of protection is only met if all connectors on the module that are not being used are closed with suitable threaded caps or slot covers! Suitable threaded caps or slot covers are available as optional accessories (X67AC0M08, X67AC0M12, 8CXC000.0000-00). The module is delivered with IP20 protection.
- 11) The temperature of the module's mounting surface is not permitted to exceed 60°C.
- 12) At ambient temperatures above 40°C, the module must be coupled to a cooling surface (machine base frame).
- 13) These dimensions refer to the actual device dimensions including the respective mounting plate. Additional spacing above and below the devices must be taken into account for mounting, connections and air circulation.

### 4.2.2.1.3 Status indicators

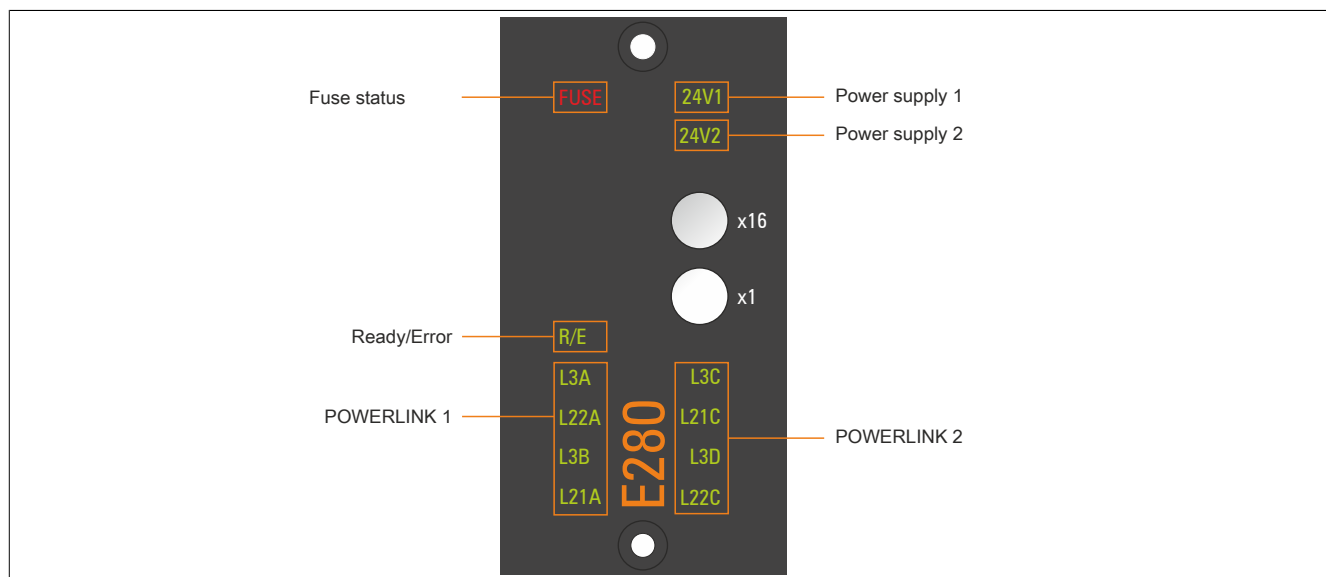

Figure 17: Indicator groups - Overview

#### 4.2.2.1.3.1 LED status indicators

Status indicator group	Label	Color	Function	Description	
Ready/Error	R/E	Green/Red	Ready/Error	see Tab. 43 "POWERLINK - LED status indicators" on page 88	
POWERLINK 1	L3A	Green	Link/Data activity on port 1		
	L22A	Green	Link/Data activity on port 2		
	L3B	Green	Link/Data activity on port 3		
	L21A	Green	Link/Data activity on port 4		
POWERLINK 2	L3C	Green	Link/Data activity on port 1		
	L21C	Green	Link/Data activity on port 2		
	L3D	Green	Link/Data activity on port 3		
	L22C	Green	Link/Data activity on port 4		
Power supplies	FUSE	Red	Fuse tripped		One or more internal fuses for the power supply have been tripped.
	24V1	Green	24 VDC 1 ready		24 VDC 1 module power supply is within the tolerance range.
	24V2	Green	24 VDC 2 ready	24 VDC 2 module power supply is within the tolerance range.	

Table 42: 8CVE remote connection box - LED status indicators

#### 4.2.2.1.3.2 POWERLINK - LED status indicators

Label	Color	Function	Description	
R/E	Green/Red	Ready/Error	LED off	The module is not receiving power or initialization of the network interface has failed.
			Solid red	The POWERLINK node number of the module is 0.
			Blinking red/green	The client is in an error state (drops out of cyclic operation).
			Blinking green (1x)	The client detects a valid POWERLINK frame on the network.
			Blinking green (2x)	Cyclic operation on the network is taking place, but the client itself is not yet a participant.
			Blinking green (3x)	Cyclic operation of the client is in preparation.
			Solid green	The client is participating in cyclic operation.
			Flickering green	The client is not participating in cyclic operation and also does not detect any other stations on the network participating in cyclic operation.
L3A L3C	Green	Link/Data activity on port 1	Solid green	A physical connection has been established to another station on the network.
L22A L21C	Green	Link/Data activity on port 2	Solid green	A physical connection has been established to another station on the network.
L3B L3D	Green	Link/Data activity on port 3	Solid green	A physical connection has been established to another station on the network.
L21A L22C	Green	Link/Data activity on port 4	Solid green	A physical connection has been established to another station on the network.

Table 43: POWERLINK - LED status indicators

#### 4.2.2.1.4 Pinouts

### Danger!

Before performing service work, disconnect the power supply and wait 5 minutes to ensure that the DC bus of the drive system has discharged. Observe regulations!

### Warning!

Drive systems can carry high levels of electrical voltage. Never connect or disconnect the connector when voltage is present!

### Information:

To satisfy UL/CSA requirements, components of B&R drive systems are only permitted to be wired with copper wires with a permitted wire temperature of at least 75°C.

#### 4.2.2.1.4.1 Overview

Up to revision C0

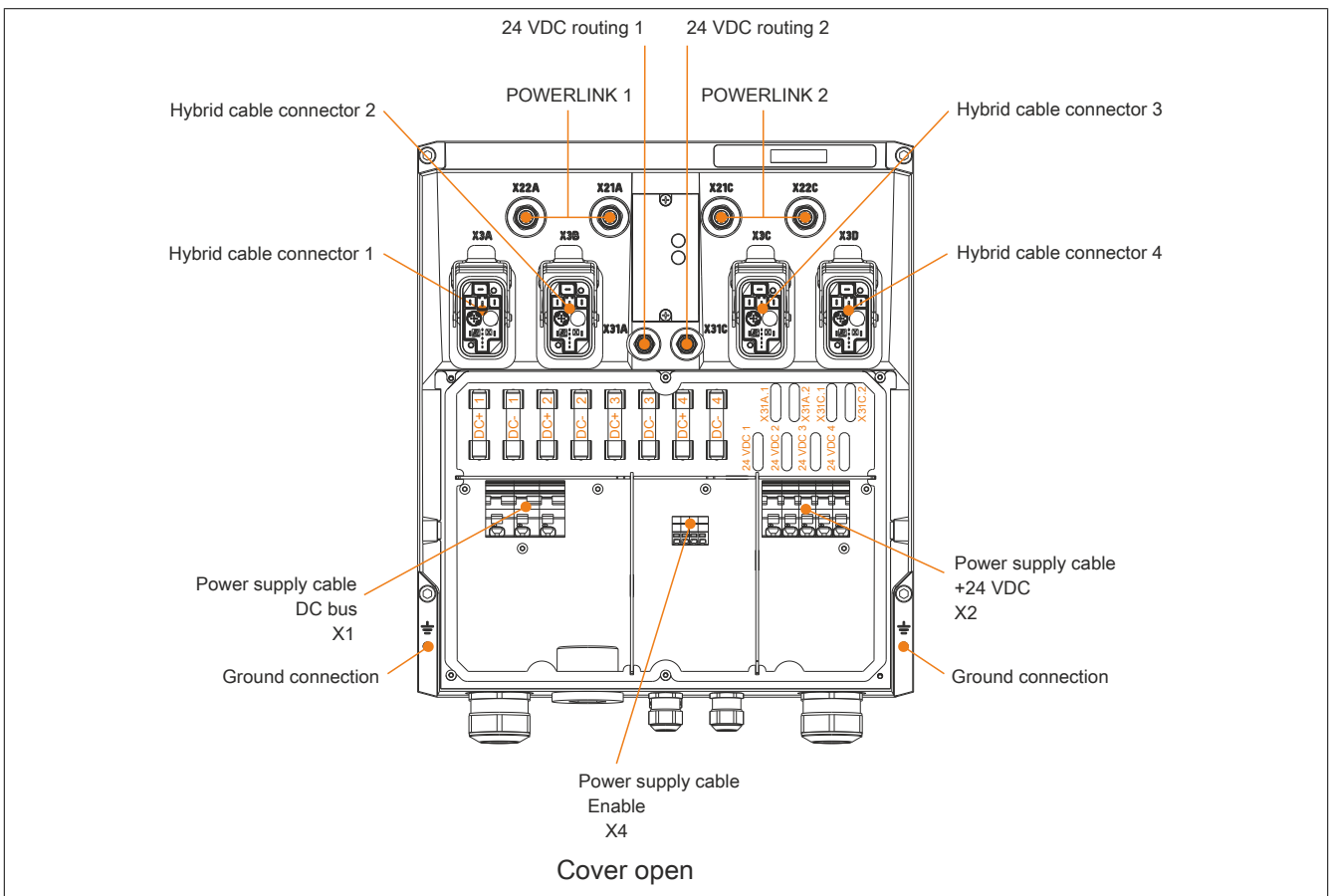

Figure 18: Pinout overview up to revision C0

Starting with revision D0

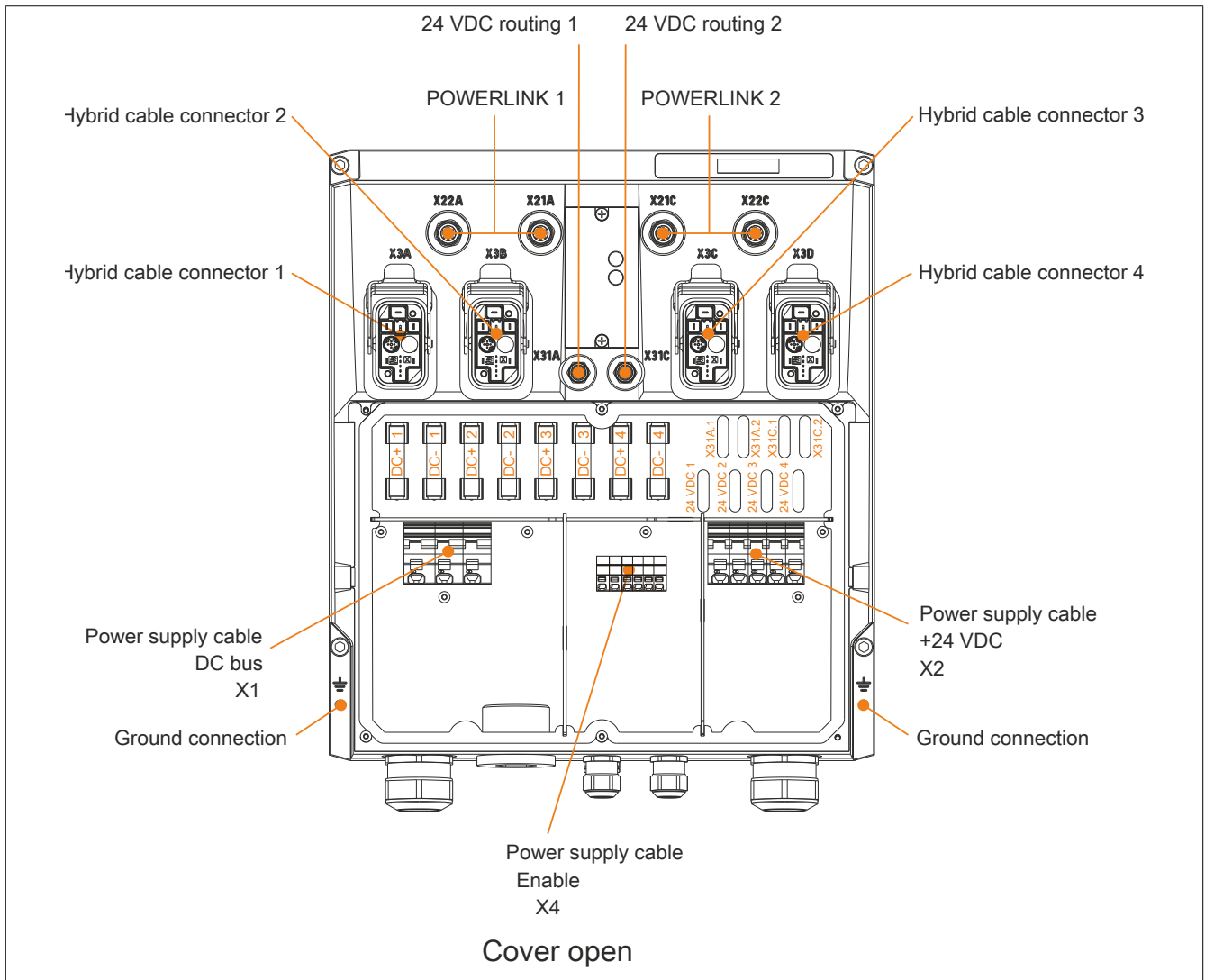

Figure 19: Pinout overview starting with revision D0

4.2.2.1.4.2 X1 (DC bus power supply cable)

Figure	Pin	Description	Function
	1	DC+ <sup>1)</sup>	U DC bus +
	2	PE	PE
	3	DC- <sup>1)</sup>	U DC bus -

Table 44: Connector X1 - Pinout

1) Wiring is not permitted to exceed a total length of 30 m.

**Information:**

B&R strongly recommends the use of a shielded cable for the DC bus power supply cable. Shielding is carried out via the cable gland.

**Caution!**

Power for 8CVE remote connection boxes is only permitted to be supplied by an ACOPOSmulti drive system (8BVE expansion module)!

#### 4.2.2.1.4.3 X2 (cable for 24 VDC power supply)

Figure	Pin	Description	Function
	1	24 VDC 1 <sup>1) 2)</sup>	24 VDC 1
	2	24 VDC 2 <sup>1) 2)</sup>	24 VDC 2 <sup>4)</sup>
	3	COM (1) <sup>3)</sup>	24 VDC 1 0 V
	4	COM (2) <sup>3)</sup>	24 VDC 2 0 V
	5	PE	Protective ground conductor

Table 45: Connector X2 - Pinout

- 1) Wiring is not permitted to exceed a total length of 30 m.
- 2) Accessory set 8CXC001.xxxxx is available to connect 24 VDC 1 and 24 VDC 2.
- 3) Accessory set 8CXC001.xxxxx is available to connect COM(1) and COM(2).
- 4) The 24 VDC power supply of the 8CVE connection pin box is provided via connections 24 VDC2 and COM(2) and is mandatory for the proper functioning of the 8CVE connection box.

### Caution!

**Power for 8CVE remote connection boxes is only permitted to be supplied by an ACOPOSmulti drive system (8BVE expansion module)!**

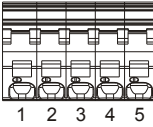
#### 4.2.2.1.4.4 X4 (enable power supply cable)

Up to revision C0

Figure	Pin	Description	Function
	1	COM (2)	Enable 2 0 V
	2	Enable 2 <sup>1)</sup>	Enable 2
	3	COM (4)	Enable 1 0 V
	4	Enable 1 <sup>1)</sup>	Enable 1

Table 46: Connector X4 - Pinout

- 1) Wiring is not permitted to exceed a total length of 30 m.

#### Starting with revision D0

Figure	Pin	Description	Function
	⊕	PE <sup>1)</sup>	Protective ground conductor
	⊕	PE <sup>1)</sup>	Protective ground conductor
	1	COM (2)	Enable 2 0 V
	2	Enable 2 <sup>2)</sup>	Enable 2
	3	COM (4)	Enable 1 0 V
	4	Enable 1 <sup>2)</sup>	Enable 1

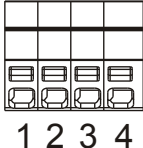
Table 47: Connector X4 - Pinout

- 1) Optional.
- 2) Wiring is not permitted to exceed a total length of 30 m.

#### 4.2.2.1.4.5 X21A, X22A, X21C, X22C (POWERLINK)

Figure	Pin	Description	Function
	1	TXD	Transmit data
	2	RXD	Receive data
	3	TXD\	Transmit data inverted
	4	RXD\	Receive data inverted

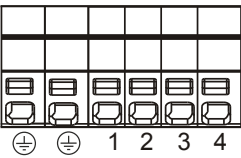
Table 48: Connector X21x/X22x - Pinout

#### 4.2.2.1.4.6 X31A, X31C (24 VDC routing)

Figure	Pin	Description	Function
	1	24 VDC I/O	24 VDC I/O power supply
	2	24 VDC I/O	24 VDC I/O power supply
	3	GND	24 VDC I/O power supply 0 V
	4	GND	24 VDC I/O power supply 0 V

Table 49: Connector X31x - Pinout

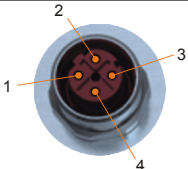
#### 4.2.2.1.4.7 Ground connection (PE)

The protective ground conductor is connected to the M5 threaded bolt provided using a cable lug.

Figure	Description	Function
	PE	Protective ground conductor
<b>Terminal cross sections</b>	<b>[mm<sup>2</sup>]</b>	<b>AWG</b>
Cable lug for M5 threaded bolt	0.25 - 16	23 - 5

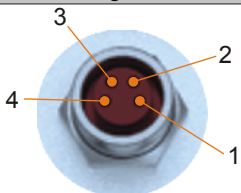
Table 50: Ground connection (PE)

#### 4.2.2.1.5 POWERLINK node number setting

The POWERLINK node number can be set using the two hexadecimal coded rotary switches located behind the module's black cover.

Removing the back cover:

- Required tool: Size 10 Torx screwdriver
- Remove the two marked mounting screws (M3x6 mm Torx screws) with the Torx screwdriver.
- Remove the back cover.

Figures		Coded rotary switches	POWERLINK node number
		1	16s position (high)
		2	1s position (low)
<p>Cover closed</p>		<p>Cover open</p>	
		<p>A change to the POWERLINK node number only takes effect the next time the ACOPOSmulti drive system is switched on.</p>	
		<p><b>Information:</b></p> <p>In principle, node numbers between \$01 and \$FD are permitted.                  However, node numbers between \$F0 and \$FD are intended for future system expansions. To ensure compatibility, these node numbers should be avoided.</p> <p>Node numbers \$00, \$FE and \$FF are reserved and are therefore not permitted to be set.</p>	

Installing the back cover:

- Required tool: Size 10 Torx screwdriver
- Place the cover on the module.
- Secure the cover with the two mounting screws (M3x6 mm Torx screws).  
Tightening torque: 0.6 Nm

#### 4.2.2.1.5.1 POWERLINK - Cabling examples

Connection box 8BVE is equipped with 2 isolated POWERLINK hubs. The connection box itself as well as all modules connected to hybrid cable connectors X21A/X22A are allocated to the first hub. All modules connected to hybrid cable connectors X21C/X22C are allocated to the second hub.

##### Cabling for a shared POWERLINK network for all hybrid cable connectors

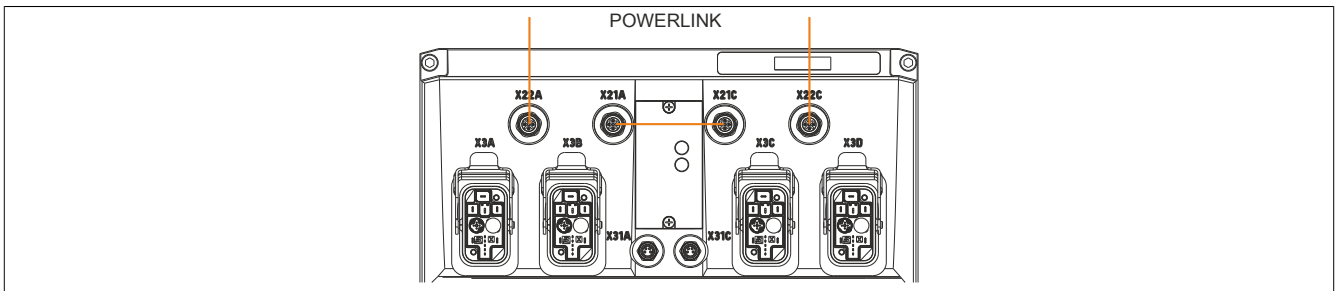

Figure 20: Cabling for a shared POWERLINK network for all hybrid cable connectors

The 2 hubs in connection box 8CVE are connected to each other. Connection box 8CVE as well as all modules connected to hybrid cable connectors X21A/X22A/X21C/X22C are part of a separate POWERLINK network.

##### Cabling for 2 independent POWERLINK networks

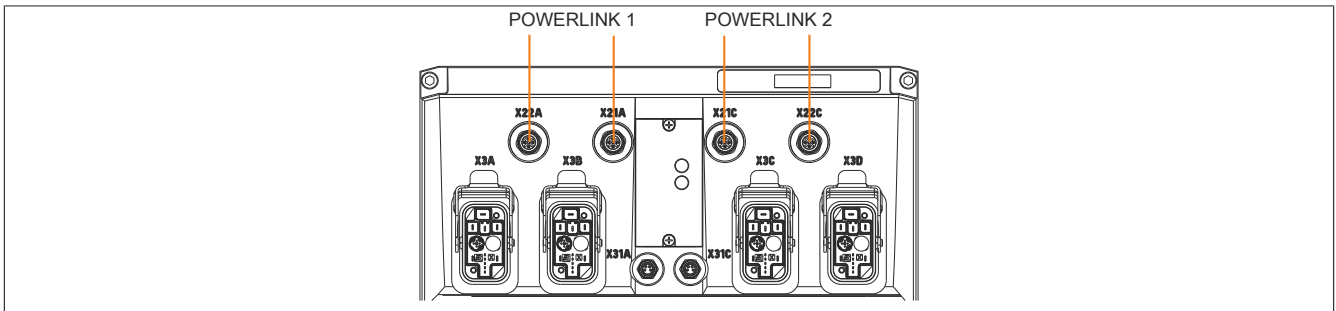

Figure 21: Cabling for 2 independent POWERLINK networks

The 2 hubs in connection box 8CVE are not connected to each other. Connection box 8CVE as well as all modules connected to hybrid cable connectors X21A/X22A are part of network POWERLINK 1. All modules connected to hybrid cable connectors X21C/X22C are part of network POWERLINK 2.

### 4.2.2.1.6 Input/Output circuit diagram

Up to revision C0

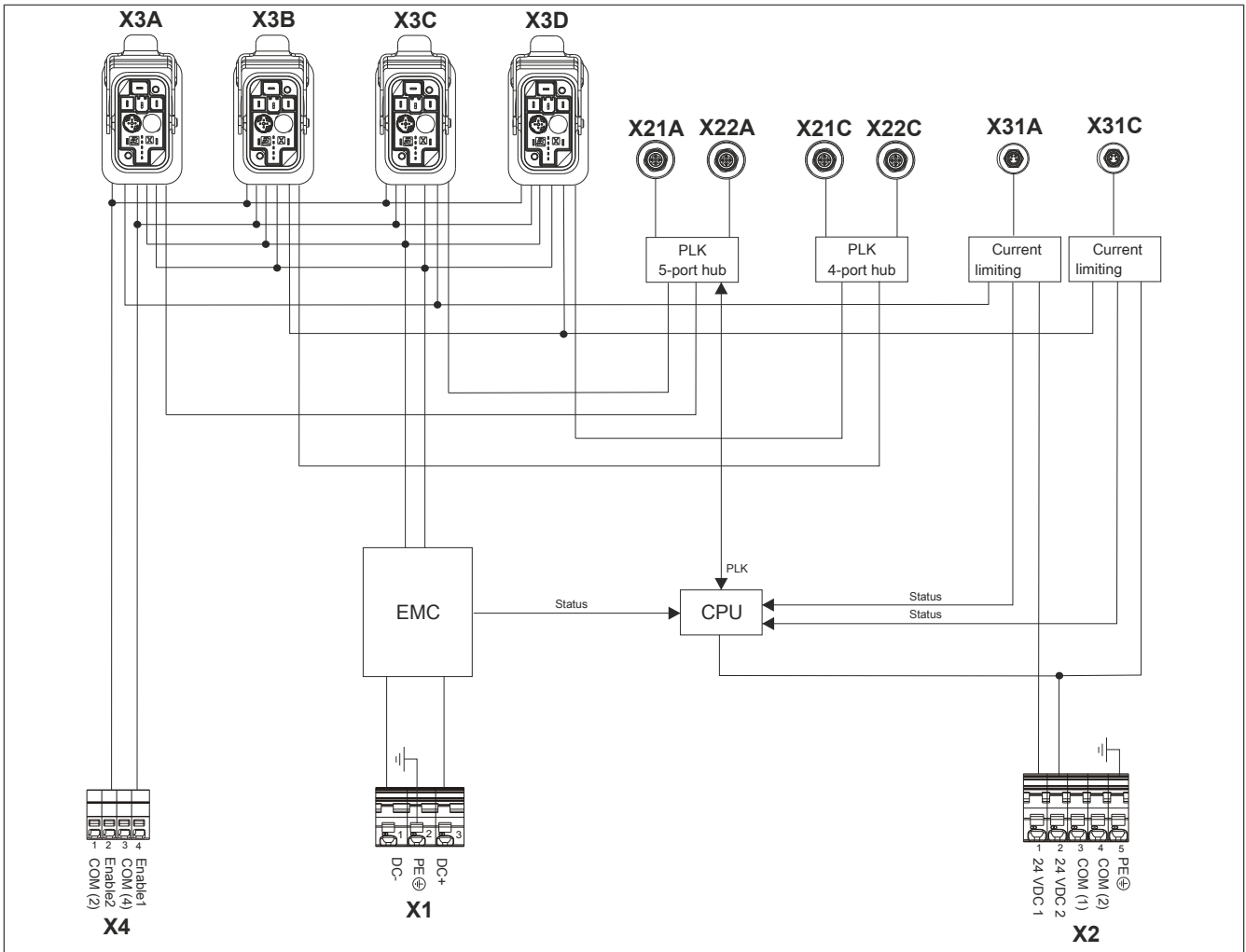

Figure 22: Connection box 8CVE - Input/Output circuit diagram

Starting with revision D0

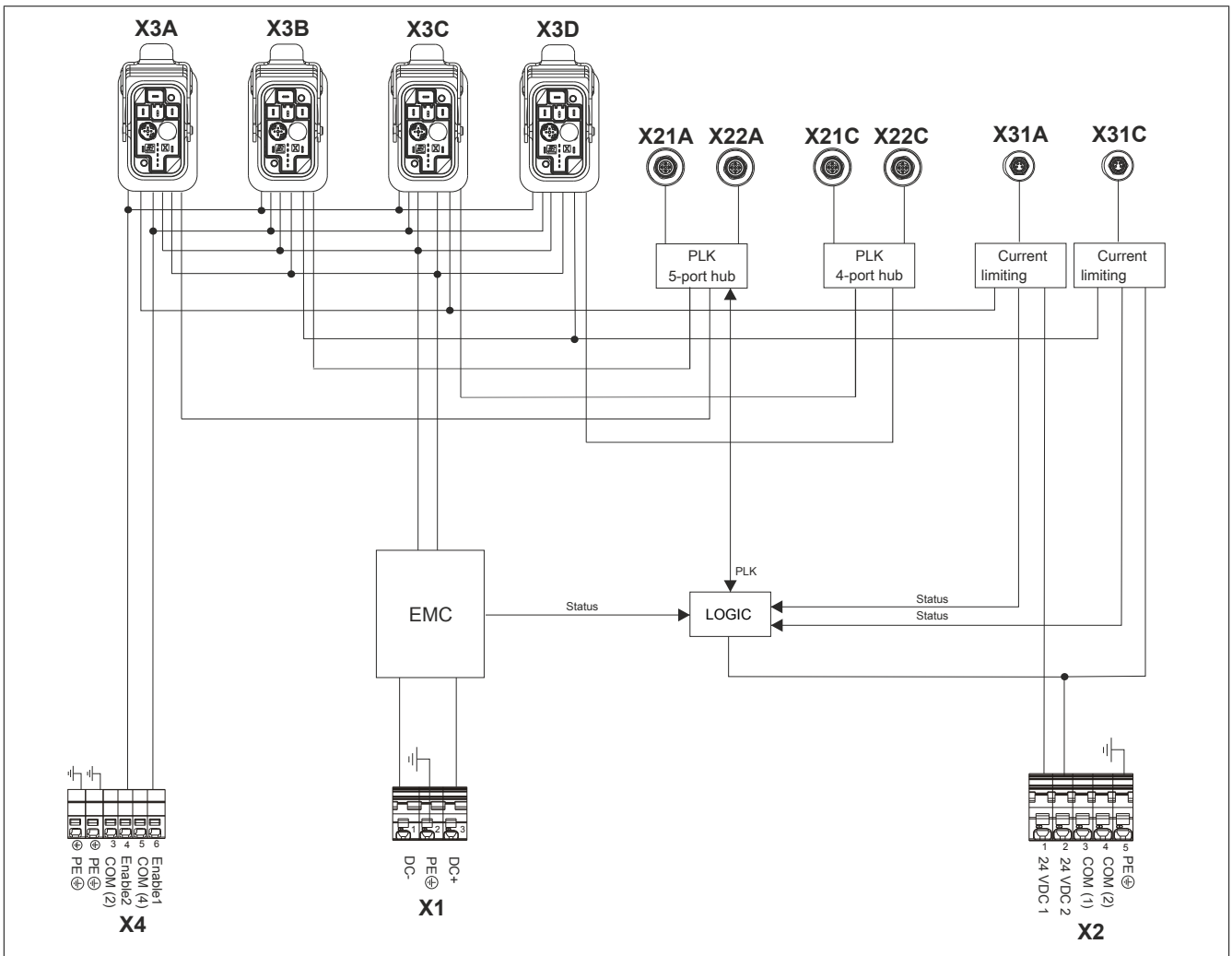

Figure 23: Connection box 8CVE - Input/Output circuit diagram

## 4.2.3 Accessories

### 4.2.3.1 General accessories

#### 4.2.3.1.1 8CXC001.0000-00

##### 4.2.3.1.1.1 Order data

Order number	Short description	Figure
	<b>Accessory sets</b>	
8CXC001.0000-00	ACOPOSremote accessory set: 2x bridge, 2-pin, fully isolated, pitch 10 mm	

Table 51: 8CXC001.0000-00 - Order data

##### 4.2.3.1.1.2 Technical data

Order number	8CXC001.0000-00
<b>General information</b>	
Short description	Accessory set for 8CVE connection box: 2x bridge, 2-pin, fully insulated, pitch 10 mm, rated current: 57 A
Certifications	
CE	Yes
UL	cULus E225616 Power conversion equipment
<b>Mechanical properties</b>	
Weight	11 g

Table 52: 8CXC001.0000-00 - Technical data

### 4.2.3.2 Screw sets

#### 4.2.3.2.1 Order data

Order number	Short description	Figure
	<b>Accessory sets</b>	
8CXM001.0000-00	ACOPOSremote accessory set: 4x M6x25 mm hex socket head screw for 8CVE connection boxes	
8CXM001.0002-00	ACOPOSremote accessory set: 20x M6x25 mm hex socket head screw for 8CVE connection boxes	
8CXM001.0005-00	ACOPOSremote accessory set: 52x M6x25 mm hex socket head screw for 8CVE connection boxes	
8CXM001.000A-00	ACOPOSremote accessory set: 100x M6x25 mm hex socket head screw for 8CVE connection boxes	

Table 53: 8CXM001.0000-00, 8CXM001.0002-00, 8CXM001.0005-00, 8CXM001.000A-00 - Order data

##### 4.2.3.2.2 Technical data

Order number	8CXM001.0000-00	8CXM001.0002-00	8CXM001.0005-00	8CXM001.000A-00
<b>General information</b>				
Short description	Accessory set for 8CVE connection boxes: 4x M6x25 mm hex socket head screw	Accessory set for 8CVE connection boxes: 20x M6x25 mm hex socket head screw	Accessory set for 8CVE connection boxes: 52x M6x25 mm hex socket head screw	Accessory set for 8CVE connection boxes: 100x M6x25 mm hex socket head screw
Certifications				
CE	Yes			
<b>Mechanical properties</b>				
Weight	30 g	143 g	413 g	752 g

Table 54: 8CXM001.0000-00, 8CXM001.0002-00, 8CXM001.0005-00, 8CXM001.000A-00 - Technical data

### 4.2.3.3 Fuse sets

#### 4.2.3.3.1 Fuse sets for 24 VDC outputs

##### 4.2.3.3.1.1 Order data

Order number	Short description	Figure
	<b>Fuse sets</b>	
8CXS001.0000-00	ACOPOSremote fuse set: 4x blade fuse 7.5 A, fast-acting	
8CXS001.0002-00	ACOPOSremote fuse set: 20x blade fuse 7.5 A, fast-acting	
8CXS001.0005-00	ACOPOSremote fuse set: 52x blade fuse 7.5 A, fast-acting	
8CXS001.000A-00	ACOPOSremote fuse set: 100x blade fuse 7.5 A, fast-acting	

Table 55: 8CXS001.0000-00, 8CXS001.0002-00, 8CXS001.0005-00, 8CXS001.000A-00 - Order data

Order number	Short description	Figure
	<b>Fuse sets</b>	
8CXS001.0000-00	ACOPOSremote fuse set: 4x flat fuse 7.5 A, fast-acting	
8CXS001.0002-00	ACOPOSremote fuse set: 20x flat fuse 7.5 A, fast-acting	
8CXS001.0005-00	ACOPOSremote fuse set: 52x flat fuse 7.5 A, fast-acting	
8CXS001.000A-00	ACOPOSremote fuse set: 100x flat fuse 7.5 A, fast-acting	

Table 56: 8CXS001.0000-00, 8CXS001.0002-00, 8CXS001.0005-00, 8CXS001.000A-00 - Order data

##### 4.2.3.3.1.2 Technical data

Order number	8CXS001.0000-00	8CXS001.0002-00	8CXS001.0005-00	8CXS001.000A-00
<b>General information</b>				
Short description	Fuse set for 8CVE connection box: 4x fuses for 24 VDC outputs  Type: Blade fuse per UL/CSA Rated current: 7.5 A Tripping characteristic: Fast-acting	Fuse set for 8CVE connection box: 20x fuses for 24 VDC outputs  Type: Blade fuse per UL/CSA Rated current: 7.5 A Tripping characteristic: Fast-acting	Fuse set for 8CVE connection box: 52x fuses for 24 VDC outputs  Type: Blade fuse per UL/CSA Rated current: 7.5 A Tripping characteristic: Fast-acting	Fuse set for 8CVE connection box: 100x fuses for 24 VDC outputs  Type: Blade fuse per UL/CSA Rated current: 7.5 A Tripping characteristic: Fast-acting
Certifications	CE Yes UL cULus E225616 Power conversion equipment			
<b>Mechanical properties</b>				
Weight	7 g	35 g	91 g	175 g

Table 57: 8CXS001.0000-00, 8CXS001.0002-00, 8CXS001.0005-00, 8CXS001.000A-00 - Technical data

#### 4.2.3.3.2 Fuse sets for hybrid cable outlets

##### 4.2.3.3.2.1 8CXS000.0000-00

##### Order data

Order number	Short description	Figure
	<b>Fuse sets</b>	
8CXS000.0000-00	ACOPOSremote fuse set: 8x fuse 10 x 38 mm, 20 A, fast-acting	

Table 58: 8CXS000.0000-00 - Order data

**Technical data**

Order number	8CXS000.0000-00
<b>General information</b>	
Short description	Fuse set for 8CVE connection box: 8x fuses for hybrid cable outlets, DC+ and DC-  Type: Melting fuse per UL/CSA, ø 10 x 38 mm Rated current: 20 A Tripping characteristic: Fast-acting
Certifications	
CE	Yes
UL	cULus E225616 Power conversion equipment
<b>Mechanical properties</b>	
Weight	68 g

Table 59: 8CXS000.0000-00 - Technical data

**4.2.3.3.2.2 8CXS002.000x-00**

**Order data**

Order number	Short description	Figure
8CXS002.0000-00	<b>Fuse sets</b> ACOPOSremote fuse set: 4x blade fuse 15 A, fast-acting	
8CXS002.0002-00	ACOPOSremote fuse set: 20x blade fuse 15 A, fast-acting	
8CXS002.0005-00	ACOPOSremote fuse set: 52x blade fuse 15 A, fast-acting	
8CXS002.000A-00	ACOPOSremote fuse set: 100x blade fuse 15 A, fast-acting	

Table 60: 8CXS002.0000-00, 8CXS002.0002-00, 8CXS002.0005-00, 8CXS002.000A-00 - Order data

**Technical data**

Order number	8CXS002.0000-00	8CXS002.0002-00	8CXS002.0005-00	8CXS002.000A-00
<b>General information</b>				
Short description	Fuse set for 8CVE connection box: 4x fuses for hybrid cable outlets, 24 VDC  Type: Blade fuse per UL/CSA Rated current: 15 A Tripping characteristic: Fast-acting	Fuse set for 8CVE connection box: 20x fuses for hybrid cable outlets, 24 VDC  Type: Blade fuse per UL/CSA Rated current: 15 A Tripping characteristic: Fast-acting	Fuse set for 8CVE connection box: 52x fuses for hybrid cable outlets, 24 VDC  Type: Blade fuse per UL/CSA Rated current: 15 A Tripping characteristic: Fast-acting	Fuse set for 8CVE connection box: 100x fuses for hybrid cable outlets, 24 VDC  Type: Blade fuse per UL/CSA Rated current: 15 A Tripping characteristic: Fast-acting
Certifications				
CE	Yes			
UL	cULus E225616 Power conversion equipment			
<b>Mechanical properties</b>				
Weight	7 g	35 g	91 g	175 g

Table 61: 8CXS002.0000-00, 8CXS002.0002-00, 8CXS002.0005-00, 8CXS002.000A-00 - Technical data

## 4.3 ACOPOSmotor

### 4.3.1 8DI - Order key

8DI c d e . ff ggg h i 0 k . h

#### Size

Valid values: **3, 4, 5**

#### Length

Valid values: **3, 4, 5, 6**

#### Safety technology

Valid values: **0, S**

#### Motor encoder system

##### Motor sizes 3 and 4

**S8/D8** ... EnDat 2.2 encoder, inductive, 19-bit single-turn

**S9/D9** ... EnDat 2.2 encoder, inductive, 19-bit single-turn, 12-bit multi-turn

##### Motor sizes 5 and 6

**SA/DA** ... EnDat 2.2 encoder, inductive, 19-bit single-turn

**SB/DB** ... EnDat 2.2 encoder, inductive, 19-bit single-turn, 12-bit multi-turn

#### Nominal speed

**022** ... 2,200 rpm

**045** ... 4,500 rpm

#### Electronics options

Valid values: **0, 7**

#### Motor options

**0** ... No oil seal, smooth shaft end, no holding brake

**1** ... Oil seal, smooth shaft end, no holding brake

**2** ... No oil seal, keyed shaft end, no holding brake

**3** ... Oil seal, keyed shaft end, no holding brake

**4** ... No oil seal, smooth shaft end, no holding brake

**5** ... Oil seal, smooth shaft end, no holding brake

**6** ... No oil seal, keyed shaft end, holding brake

**7** ... Oil seal, keyed shaft end, holding brake

#### Special motor options

**0** ... No special motor option

**1** ... Special motor option special-purpose shaft 14h6, shaft length 30 mm

#### Motor version

**1** ... Version 1

## Note:

Order keys only provide information about possible combinations in exceptional cases.

### 4.3.1.1 Size (c)

8DI ACOPOSmotor modules are available in three different sizes (3, 4 and 5). They have different dimensions (especially flange dimensions) and power ratings. These different sizes are indicated by a number represented by (c) in the model number. The larger the number, the larger the flange dimensions and power rating for the ACOPOSmotor module.

### 4.3.1.2 Length (d)

8DI ACOPOSmotor modules are available in three different sizes. They have different power ratings with identical flange dimensions. These different lengths are indicated by a number represented by (d) in the model number.

Length	Available sizes		
	3	4	5
3	Yes	No	No
4	Yes	Yes	Yes
5	No	Yes	Yes
6	No	Yes	Yes

### 4.3.1.3 Safety technology (e)

By default, ACOPOSmotor 8DI modules are delivered with wired safety technology or SafeMOTION EnDat 2.2.

Name	Note	Code for order key
Wired safety technology	---	0
SafeMOTION EnDat 2.2	---	S

The following table lists the safety functions integrated in ACOPOSmotor SafeMOTION modules as well as the safety levels that can be achieved when they are used:

Safety function	ACOPOSmotor SafeMOTION	EN ISO 13849-1	EN 61508 / EN 62061	Safe Encoder evaluation Necessary
	<b>Starting in Safety Release</b>			
Safe Torque Off (STO)	R 1.10	PL e / Cat. 4	SIL 3	No
Safe Torque Off One Channel (STO1)	R 1.10	PL d / Cat. 3	SIL 2	No
Safe Operation Stop (SOS)	R 1.10	PL d / Cat. 3	SIL 2	Yes
Safe Stop 1 (SS1)	R 1.10	Time-based monitoring: PL e / Cat. 4 Ramp-based monitoring: PL d / Cat. 3	Time-based monitoring: SIL 3 Ramp-based monitoring: SIL 2	Time-based monitoring: No Ramp-based monitoring: Yes
Safe Stop 2 (SS2)	R 1.10	PL d / Cat. 3	SIL 2	Yes
Safely Limited Speed (SLS)	R 1.10	PL d / Cat. 3	SIL 2	Yes
Safe Maximum Speed (SMS)	R 1.10	PL d / Cat. 3	SIL 2	Yes
Safe Direction (SDI)	R 1.10	PL d / Cat. 3	SIL 2	Yes
Safely Limited Increment (SLI)	R 1.10	PL d / Cat. 3	SIL 2	Yes
Safely Limited Acceleration (SLA)	R 1.10	PL d / Cat. 3	SIL 2	Yes
Safe Brake Control (SBC) <sup>1)</sup>	R 1.10	PL d / Cat. 3	SIL 2	No
Safely Limited Position (SLP)	R 1.10	PL d / Cat. 3	SIL 2	Yes
Safe Maximum Position (SMP)	R 1.10	PL d / Cat. 3	SIL 2	Yes
Safe Homing	R 1.10	PL d / Cat. 3	SIL 2	Yes
Remanent Safe Position (RSP)	R 1.10	PL d / Cat. 3	SIL 2	Yes

Table 62: ACOPOSmotor SafeMOTION: Safety functions and associated safety levels

1) Safety function SBC does not apply to the motor holding brake integrated in the ACOPOSmotor SafeMOTION; it is not safety-related.

#### 4.3.1.4 Encoder system (ff)

##### EnDat 2.2 encoder

##### General information

Digital drive systems and position control loops require fast and highly secure transfer of data obtained from position measuring instruments. In addition, other data such as drive-specific characteristics, correction tables, etc. should also be available. To ensure a high level of system security, measuring instruments must be integrated in routines for detecting errors and be able to perform diagnostics.

The EnDat interface from HEIDENHAIN is a digital, bidirectional interface for measuring instruments. It is able to output position values from incremental and absolute measuring instruments and can also read and update information on the measuring instrument or store new data there. Because it relies on serial data transfer, only 4 signal lines are needed. Data is transferred synchronously to the clock signal defined by the subsequent electronics. The type of transfer used (e.g. for position values, parameters, diagnostics, etc.) is selected using mode commands sent to the measuring instrument by the subsequent electronics.

As a serial interface, EnDat 2.2 is also suitable for safety-related applications up to SIL 3.

##### Technical data

Description				
Order code (ff)	S8/D8	S9/D9	SA/DA	SB/DB
Can be used with	Size 3	Size 3	Sizes 4 and 5	Sizes 4 and 5
Encoder type	EnDat single-turn functional safety	EnDat multi-turn functional safety	EnDat single-turn functional safety	EnDat multi-turn functional safety
Operating principle	Inductive			
EnDat protocol	EnDat 2.2			
Position values per revolution	524,288 (19-bit)			
Distinguishable revolutions	---	4096 (12-bit)	---	4096 (12-bit)
Precision	±120"		±65"	
Vibration during operation 55 to 2,000 Hz	Stator: ≤400 m/s <sup>2</sup> , rotor: ≤600 m/s <sup>2</sup> (EN 60068-2-6) <sup>1)</sup>		Stator: ≤200 m/s <sup>2</sup> , rotor: ≤600 m/s <sup>2</sup> (IEC 60068-2-6) <sup>2)</sup>	
Shock during operation Duration 6 ms	≤2,000 m/s <sup>2</sup> (EN 60068-2-27)			
Manufacturer's website	Dr. Johannes Heidenhain GmbH <a href="http://www.heidenhain.de">www.heidenhain.de</a>			
Manufacturer's product ID	ECl 1119	EQI 1131	ECl 1319	EQI 1331

- Valid according to standard at room temperature,
  - 10 to 55 Hz, constant path, 4.9 mm peak to peak
  - 10 to 55 Hz, constant lift, 4.9 mm peak to peak
  - 10 to 55 Hz, constant amplitude, 4.9 mm peak to peak
- In accordance with the standard at room temperature; the following values apply at a working temperature up to 100°C: ≤300 m/s<sup>2</sup>, up to 115°C: ≤150 m/s<sup>2</sup>.
  - 10 to 55 Hz, constant path, 4.9 mm peak to peak
  - 10 to 55 Hz, constant lift, 4.9 mm peak to peak
  - 10 to 55 Hz, constant amplitude, 4.9 mm peak to peak

#### 4.3.1.5 Nominal speed (ggg)

The nominal speed is listed as part of the model number in the form of a 3-digit code (ggg). This code represents the nominal speed divided by 100.

Size	Available nominal speeds $n_N$ [rpm]					
	2200 (code for order key: 022)			4500 (code for order key: 045)		
3	No	No	No	Yes	Yes	
4	Yes	Yes	Yes	No	No	
5	Yes	Yes	Yes	No	No	
Length	4	5	6	3	4	

#### 4.3.1.6 Electronics options (h)

8DI ACOPOSmotor modules are available with optional external connections:

- One additional POWERLINK connection
- Two 24 VDC outputs for supplying external components (e.g. X67 modules)
- Two trigger inputs

The respective execution of the module is listed in the form of a 1-digit code (h) as part of the model number.

POWERLINK	24 VDC outputs (2x)	Trigger inputs (2x)	Code for order key
No	No	No	0
Yes	Yes	Yes	7

#### 4.3.1.7 Motor options (i)

8DI ACOPOSmotor modules are available with the following features depending on size and length:

- With or without a holding brake
- With a smooth or keyed shaft end
- With or without an oil seal

The respective combination of motor options is listed in the form of a 1-digit code (i) as part of the model number.

Code for order key (i)	Holding brake	Design of the shaft end	Oil seal
0	No	Smooth shaft end	No
1			Yes
2		Keyed shaft end	No
3			Yes
4	Yes	Smooth shaft end	No
5			Yes
6		Keyed shaft end	No
7			Yes

#### Holding brake

All 8DI ACOPOSmotor modules can be delivered with a holding brake. It is installed directly behind the A-side flange on the module and is used to hold the motor shaft when the power is switched off on the ACOPOSmotor module.

The holding brake is a spring-loaded brake. Based on principle, this type of holding brake exhibits a minimal amount of backlash.

This brake is designed as a holding brake and is not permitted to be used for operational braking! Under these conditions, the brake has a service life of approximately 5,000,000 cycles (opening and closing the brake is one cycle). Loaded braking during an emergency stop is permitted but reduces its service life. The required brake holding torque is determined based on the actual load torque. If not enough information is known about the load torque, it is recommended to assume a safety factor of 2.

Name	ACOPOSmotor module		
	8DI3...	8DI4...	8DI5...
Holding torque $M_{Br}$ [Nm]	3.2	9	18
Connected load $P_{On}$ [W]	12	18	24
Activation delay $t_{on}$ [ms]	29	40	50
Release delay $t_{off}$ [ms]	19	7	10
Moment of inertia $J_{Br}$ [kgcm <sup>2</sup> ]	0.38	0.54	1.66
Mass $m_{Br}$ [kg]	0.3	0.46	0.9

Table 63: Technical data for the holding brake per ACOPOSmotor module

#### Design of the shaft end

8DI ACOPOSmotor module shafts comply with the DIN 748 standard and are available with a smooth or keyed shaft end.

##### Smooth shaft end

A smooth shaft end is used for a force-fit shaft-hub connection and guarantees a backlash-free connection between the shaft and hub as well as a high degree of operating smoothness. The end of the shaft has a threaded center hole.

##### Keyed shaft end

A keyed shaft end is used for a form-fit torque transfer with low demands on the shaft-hub connection and for handling torque in a constant direction.

The keyways for 8DI ACOPOSmotor modules conform to keyway form N1 in accordance with DIN 6885-1. Form A keyed shafts that conform to DIN 6885-1 are used. Balancing motors with keyways is done using the shaft and fitment key convention in accordance with DIN ISO 8821.

The end of the shaft has a threaded center hole that can be used to mount machine actuators with shaft end cover plates.

**Oil seal**

All 8DI ACOPOSmotor modules are available with an optional Form A oil seal in accordance with DIN 3760. When equipped with an oil seal, 8DI ACOPOSmotor modules have IP65 protection in accordance with EN 60034-5. Proper lubrication of the oil seal must be ensured throughout the entire service life of the motor.

**4.3.1.8 Special motor options (k)**

The respective special motor option is specified as part of the order number in the form of a 1-digit code (k).

**Availability of special motor options**

For the availability of special motor options, see the following tables.

Order code (k)	Special motor option	No special motor option
	Special-purpose shaft 14h6, shaft length 30 mm	
0	---	Yes
1	Yes	---

**4.3.1.9 Version**

ACOPOSmotor module versions are assigned automatically.

**4.3.2 8ZDFB fan kits**



8DI ACOPOSmotor modules can be optionally equipped with a fan kit depending on size. The fan kit considerably improves the nominal values of 8DI ACOPOSmotor modules (see speed-torque characteristic curve for the respective 8DI ACOPOSmotor module).

The fan kit is mounted on the back of the 8DI ACOPOSmotor module, with 24 VDC supplied to the fan kit either externally or via connector X31 on the ACOPOSmotor module (8DIcde.ffggg7i00-1).

Size	Corresponding fan kit
3	In preparation
4	8ZDFB4000000.000-0
5	8ZDFB5000000.000-0

### 4.3.3 Load capacity of the shaft end and bearings

8DI ACOPOSmotor modules are equipped with grooved ball bearings that are sealed on both sides and lubricated. Radial and axial forces ( $F_r$ ,  $F_a$ ) applied to the shaft end during operation and installation must be within the specifications listed below. Bearing elements must not be subjected to shocks or impacts! Incorrect handling will reduce the service life and result in damage to the bearings.

The axial forces  $F_a$  permitted during the installation of pinion gears, couplings, etc. depend on the size of the ACOPOSmotor module and can be found in the following table:

Size	Permissible axial force $F_a$ [N]
	Standard bearing
3	1400
4	2300
5	2500

#### Radial force

The radial force  $F_r$  on the shaft end is a function of the loads during installation (e.g. belt tension on pulleys) and operation (e.g. load torque on the pinion). The maximum radial force  $F_r$  depends on the shaft end type, bearing type, average speed, the position where the radial force is applied and the desired service life of the bearings.

#### Axial force, shift in shaft position caused by axial force

The axial force  $F_a$  on the shaft end is a function of the loads during installation (e.g. stress caused by mounting) and operation (e.g. thrust caused by slanted tooth pinions). The maximum axial force  $F_a$  depends on the bearing type and the desired lifespan of the bearings. The fixed bearing is secured on the A flange with a retaining ring. The floating bearing is preloaded on the B flange with a spring in the direction of the A flange. Axial forces in the direction of the B flange can cause the spring bias to be overcome, which shifts the shaft by the amount of axial backlash in the bearing (approx. 0.1 - 0.2 mm). This shift can cause problems on ACOPOSmotor modules with holding brakes or ACOPOSmotor modules with EnDat encoders (D8, D9, DA and DB). As a result, no axial force is permitted in the direction of the B flange when using these ACOPOSmotor modules.

Axial loads are not permitted on shaft ends of ACOPOSmotor modules with holding brakes. It is especially important to prevent axial forces in the direction of the B flange since these forces can cause the brake to fail!

#### Determining permissible values of $F_r$ and $F_a$

Information for determining permissible values of  $F_r$  and  $F_a$  can be found in the technical data for the respective ACOPOSmotor modules. Permissible values are based on a bearing lifespan of 20,000 h (bearing lifespan calculation based on DIN ISO 281).

#### Definitions for maximum shaft load diagrams

- $F_r$ ..... Radial force
- $F_a$ ..... Axial force
- $x$ ..... Distance between the motor flange and the point where radial force  $F_r$  is applied

### 4.3.5 ACOPOSmotor modules - Indicators

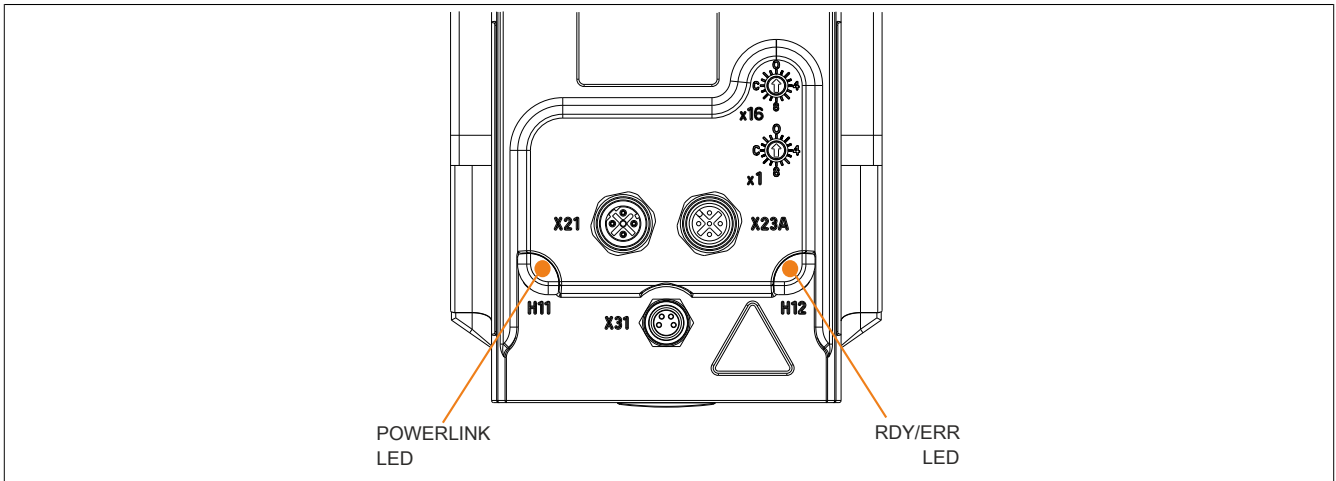

Figure 24: 8DI - Status indicators

#### 4.3.5.1 POWERLINK - LED status indicators

Label	Color	Function	Description	
H11	Green/Red	Ready/Error	LED off	The module is not receiving power or initialization of the network interface has failed.
			Solid red	The POWERLINK node number of the module is 0.
			Blinking red/green	The client is in an error state (drops out of cyclic operation).
			Blinking green (1x)	The client detects a valid POWERLINK frame on the network.
			Blinking green (2x)	Cyclic operation on the network is taking place, but the client itself is not yet a participant.
			Blinking green (3x)	Cyclic operation of the client is in preparation.
			Solid green	The client is participating in cyclic operation.
			Flickering green	The client is not participating in cyclic operation and also does not detect any other stations on the network participating in cyclic operation.

Table 64: POWERLINK - LED status indicators

#### 4.3.5.2 RDY/ERR - LED status indicators

Label	Color	Function	Description	
H12	Green	Ready	Solid green	The module is operational and the power stage can be enabled (operating system present and booted, no permanent or temporary errors).
			Blinking green	The module is not ready for operation. <b>Examples:</b> <ul style="list-style-type: none"> <li>No signal on one or both enable inputs</li> <li>DC bus voltage outside the tolerance range</li> <li>Overtemperature on the motor (temperature sensor)</li> <li>Motor feedback not connected or defective</li> <li>Motor temperature sensor not connected or defective</li> <li>Overtemperature on the module (IGBT junction, heat sink, etc.)</li> <li>Disturbance on network</li> </ul>
	Red	Error	Solid red	There is a permanent error on the module. <b>Examples:</b> <ul style="list-style-type: none"> <li>Permanent overcurrent</li> <li>Invalid data in EPROM</li> </ul>

Table 65: RDY/ERR - LED status indicators

### 4.3.5.3 Status changes when starting up the operating system loader

The following intervals are used for the LED status indicators:

Width of box: 50 ms

Repeats after: 3,000 ms

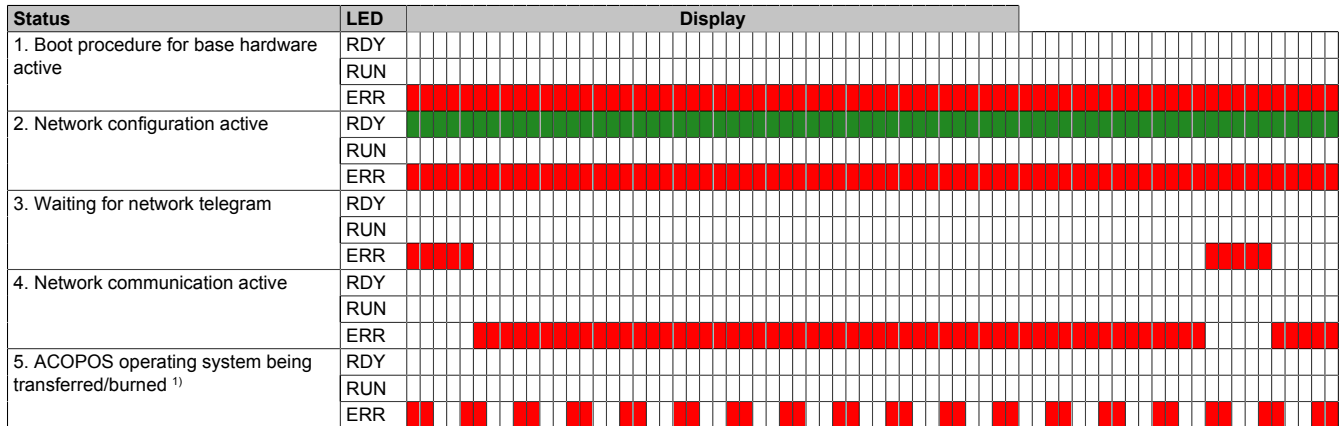

Table 66: Status changes when starting up the operating system loader

1) Firmware V2.140 and later.

### 4.3.6 ACOPOSmotor SafeMOTION - Indicators

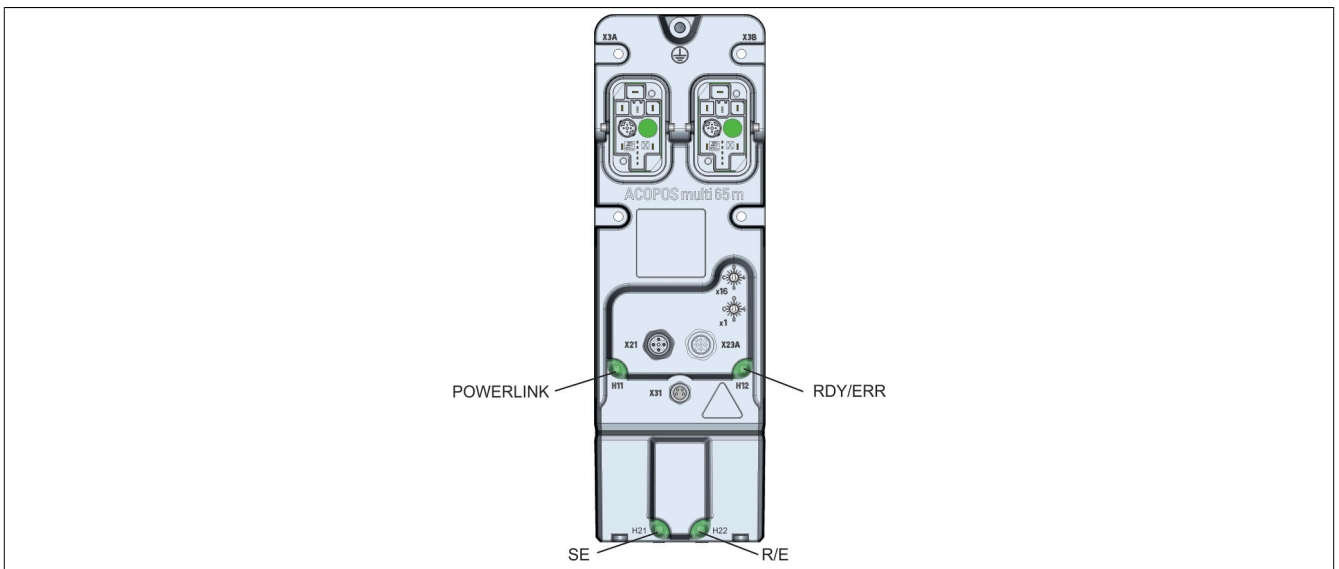

Figure 25: ACOPOSmotor SafeMOTION - Display

#### 4.3.6.1 LED status indicators

Status indicator group	Label	Color	Function	Description
POWERLINK	R/E	Green/Red	Ready/Error	see "POWERLINK - LED status indicators" on page 107
Power inverter	RDY	Green	Ready	see "RDY/ERR - LED status indicators" on page 107
	RUN	Orange	Run	
	ERR	Red	Error	
Power supply	24 V	Green	24 V OK	The 24 V module power supply voltage is within the tolerance range.
Status of SafeMOTION module	R/E	Green/Red	Ready/Error	see "SafeMOTION module - LED status indicators" on page 107
Safety status of SafeMOTION module	SE	Red	Safe/Error	

Table 67: 8BVI SafeMOTION inverter modules (1-axis modules) - LED status indicators

### 4.3.6.2 RDY/ERR - LED status indicators

Label	Color	Function	Description
H12	Green	Ready	Solid green The module is operational and the power stage can be enabled (operating system present and booted, no permanent or temporary errors).
			Blinking green The module is not ready for operation. <b>Examples:</b> <ul style="list-style-type: none"> <li>No signal on one or both enable inputs</li> <li>DC bus voltage outside the tolerance range</li> <li>Overtemperature on the motor (temperature sensor)</li> <li>Motor feedback not connected or defective</li> <li>Motor temperature sensor not connected or defective</li> <li>Overtemperature on the module (IGBT junction, heat sink, etc.)</li> <li>Disturbance on network</li> </ul>
	Red	Error	Solid red There is a permanent error on the module. <b>Examples:</b> <ul style="list-style-type: none"> <li>Permanent overcurrent</li> <li>Invalid data in EPROM</li> </ul>

Table 68: RDY/ERR - LED status indicators

### 4.3.6.3 POWERLINK - LED status indicators

Label	Color	Function	Description
H11	Green/Red	Ready/Error	LED off The module is not receiving power or initialization of the network interface has failed.
			Solid red The POWERLINK node number of the module is 0.
			Blinking red/green The client is in an error state (drops out of cyclic operation).
			Blinking green (1x) The client detects a valid POWERLINK frame on the network.
			Blinking green (2x) Cyclic operation on the network is taking place, but the client itself is not yet a participant.
			Blinking green (3x) Cyclic operation of the client is in preparation.
			Solid green The client is participating in cyclic operation.
			Flickering green The client is not participating in cyclic operation and also does not detect any other stations on the network participating in cyclic operation.

Table 69: POWERLINK - LED status indicators

### 4.3.6.4 SafeMOTION module - LED status indicators

LED	Function	Color	Description		
H22	Ready/Error	Green	Red		
		Off		Module not supplied with current, no communication	
		Single flash		Unlink mode	
		Double flash		Updating firmware	
		Blinking		PREOPERATIONAL mode	
		On		Mode RUN	
		On		Single flash, inverse	Safety-related firmware invalid
				Triple flash, inverse	Updating safety-related firmware
				On	Communication error
				Off	On
H21	Safe/Error	Red	Off	Mode RUN	
		On	Non-acknowledgeable error state, FAIL SAFE state		
The two "H21" indicators are two separate LEDs that show the states of safety processor 1 and safety processor 2.					

Table 70: SafeMOTION module - LED status indicators

## Danger!

Constantly lit "SE" LEDs indicate a non-acknowledgeable FAIL SAFE state. The cause of this could be a defective module or faulty configuration.

Check the entries in the logbook! If you are able to rule out a faulty configuration, then the module is defective and must be replaced immediately.

It is your responsibility to ensure that all necessary repair measures or corrections to the configuration are initiated after an error occurs since subsequent errors can result in dangerous situations!

### 4.3.6.5 Status changes when starting up the operating system loader

The following intervals are used for the LED status indicators:

Width of box: 50 ms

Repeats after: 3,000 ms

Status	LED	Display
1. Boot procedure for base hardware active	RDY	[Grid]
	RUN	[Grid]
	ERR	[Red blocks]
2. Network configuration active	RDY	[Green blocks]
	RUN	[Grid]
	ERR	[Red blocks]
3. Waiting for network telegram	RDY	[Grid]
	RUN	[Grid]
	ERR	[Red blocks]
4. Network communication active	RDY	[Grid]
	RUN	[Grid]
	ERR	[Red blocks]
5. ACOPOS operating system being transferred/burned <sup>1)</sup>	RDY	[Grid]
	RUN	[Grid]
	ERR	[Red blocks]

Table 71: Status changes when starting up the operating system loader

1) Firmware V2.140 and later.

### 4.3.7 ACOPOSmotor with electronic options - Order data

Model number	Short description	Figure
8DIcde.ffggg7i00-1	ACOPOSmotor module configuration with electronics options 1x PLK, 1x 24VOut, 2x trigger	
<b>Required accessories</b>		
<b>Threaded caps</b>		
X67AC0M08	X67 threaded caps M8, 50 pcs.	
X67AC0M12	X67 threaded caps M12, 50 pcs.	
<b>Accessory sets</b>		
8CXC000.0000-00	Accessory set: 1x slot cover for male hybrid connector	
<b>Optional accessories</b>		
<b>Hybrid cables</b>		
8CCH0001.11110-1	Hybrid cable, length 1 m, 2x 2x 0.34 mm <sup>2</sup> +4x 0.75 mm <sup>2</sup> + 5x 2.5 mm <sup>2</sup> , 2x 15-pin female hybrid connector	
8CCH0002.11110-1	Hybrid cable, length 2 m, 2x 2x 0.34 mm <sup>2</sup> +4x 0.75 mm <sup>2</sup> + 5x 2.5 mm <sup>2</sup> , 2x 15-pin female hybrid connector	
8CCH0005.11110-1	Hybrid cable, length 5 m, 2x 2x 0.34 mm <sup>2</sup> +4x 0.75 mm <sup>2</sup> + 5x 2.5 mm <sup>2</sup> , 2x 15-pin female hybrid connector	
8CCH01X1.11110-1	Hybrid cable, length 1.10 m, 2x 2x 0.34 mm <sup>2</sup> +4x 0.75 mm <sup>2</sup> + 5x 2.5 mm <sup>2</sup> , 2x 15-pin female hybrid connector	
8CCH01X2.11110-1	Hybrid cable, length 1.20 m, 2x 2x 0.34 mm <sup>2</sup> +4x 0.75 mm <sup>2</sup> + 5x 2.5 mm <sup>2</sup> , 2x 15-pin female hybrid connector	
<b>I/O supply cable</b>		
X67CA0P00.0010	Power connection cable, 1 m	
X67CA0P00.0020	Power connection cable, 2 m	
X67CA0P00.0050	Power connection cable, 5 m	
X67CA0P10.0010	Power connection cable, angled, 1 m	
X67CA0P10.0020	Power connection cable, angled, 2 m	
X67CA0P10.0050	Power connection cable, angled, 5 m	
X67CA0P40.0002	Power open cable, 0.20m	
X67CA0P40.0020	Power open cable, 2m	
X67CA0P40.0050	Power open cable, 5m	
<b>Assembled cables</b>		
X67CA0E41.0010	POWERLINK attachment cable, RJ45 to M12, 1 m	
X67CA0E41.0050	POWERLINK attachment cable, RJ45 to M12, 5 m	
X67CA0E61.0020	POWERLINK connection cable, M12 to M12, 2 m	
X67CA0E61.0050	POWERLINK connection cable, M12 to M12, 5 m	
X67CA0E61.0100	POWERLINK connection cable, M12 to M12, 10 m	
<b>Sensor cable</b>		
X67CA0A41.0020	M12 sensor cable, 2 m	
X67CA0A41.0050	M12 sensor cable, 5 m	
X67CA0A41.0100	M12 sensor cable, 10 m	
X67CA0A51.0020	M12 sensor cable, angled, 2 m	
X67CA0A51.0050	M12 sensor cable, angled, 5 m	
X67CA0A51.0100	M12 sensor cable, angled, 10 m	
<b>8BVE/8CVI connection cables</b>		
8CCH0002.11120-1	Hybrid cable for connecting 8BVE to 8CVI or 8DI, length 2 m, 2x 2x 0.34 mm <sup>2</sup> + 4x 0.75 mm <sup>2</sup> + 5x 2.5 mm <sup>2</sup> , 1x 15-pin female hybrid connector	
8CCH0005.11120-1	Hybrid cable for connecting 8BVE to 8CVI or 8DI, length 5 m, 2x 2x 0.34 mm <sup>2</sup> + 4x 0.75 mm <sup>2</sup> + 5x 2.5 mm <sup>2</sup> , 1x 15-pin female hybrid connector	
8CCH0007.11120-1	Hybrid cable for connecting 8BVE to 8CVI or 8DI, length 7 m, 2x 2x 0.34 mm <sup>2</sup> + 4x 0.75 mm <sup>2</sup> + 5x 2.5 mm <sup>2</sup> , 1x 15-pin female hybrid connector	
8CCH0010.11120-1	Hybrid cable for connecting 8BVE to 8CVI or 8DI, length 10 m, 2x 2x 0.34 mm <sup>2</sup> + 4x 0.75 mm <sup>2</sup> + 5x 2.5 mm <sup>2</sup> , 1x 15-pin female hybrid connector	

Table 72: 8DIcde.ffggg7i00-1 - Order data

### 4.3.8 ACOPOSmotor without electronic options - Order data

Model number	Short description	Figure
	<b>ACOPOSmotor</b>	
8DIcde.ffggg0i00-1	ACOPOSmotor module configuration without electronics options	
	<b>Required accessories</b>	
	<b>Accessory sets</b>	
8CXC000.0000-00	Accessory set: 1x slot cover for male hybrid connector	
	<b>Optional accessories</b>	
	<b>Hybrid cables</b>	
8CCH0001.11110-1	Hybrid cable, length 1 m, 2x 2x 0.34 mm <sup>2</sup> +4x 0.75 mm <sup>2</sup> + 5x 2.5 mm <sup>2</sup> , 2x 15-pin female hybrid connector	
8CCH0002.11110-1	Hybrid cable, length 2 m, 2x 2x 0.34 mm <sup>2</sup> +4x 0.75 mm <sup>2</sup> + 5x 2.5 mm <sup>2</sup> , 2x 15-pin female hybrid connector	
8CCH0005.11110-1	Hybrid cable, length 5 m, 2x 2x 0.34 mm <sup>2</sup> +4x 0.75 mm <sup>2</sup> + 5x 2.5 mm <sup>2</sup> , 2x 15-pin female hybrid connector	
8CCH01X1.11110-1	Hybrid cable, length 1.10 m, 2x 2x 0.34 mm <sup>2</sup> +4x 0.75 mm <sup>2</sup> + 5x 2.5 mm <sup>2</sup> , 2x 15-pin female hybrid connector	
8CCH01X2.11110-1	Hybrid cable, length 1.20 m, 2x 2x 0.34 mm <sup>2</sup> +4x 0.75 mm <sup>2</sup> + 5x 2.5 mm <sup>2</sup> , 2x 15-pin female hybrid connector	
	<b>8BVE/8CVI connection cables</b>	
8CCH0002.11120-1	Hybrid cable for connecting 8BVE to 8CVI or 8DI, length 2 m, 2x 2x 0.34 mm <sup>2</sup> + 4x 0.75 mm <sup>2</sup> + 5x 2.5 mm <sup>2</sup> , 1x 15-pin female hybrid connector	
8CCH0005.11120-1	Hybrid cable for connecting 8BVE to 8CVI or 8DI, length 5 m, 2x 2x 0.34 mm <sup>2</sup> + 4x 0.75 mm <sup>2</sup> + 5x 2.5 mm <sup>2</sup> , 1x 15-pin female hybrid connector	
8CCH0007.11120-1	Hybrid cable for connecting 8BVE to 8CVI or 8DI, length 7 m, 2x 2x 0.34 mm <sup>2</sup> + 4x 0.75 mm <sup>2</sup> + 5x 2.5 mm <sup>2</sup> , 1x 15-pin female hybrid connector	
8CCH0010.11120-1	Hybrid cable for connecting 8BVE to 8CVI or 8DI, length 10 m, 2x 2x 0.34 mm <sup>2</sup> + 4x 0.75 mm <sup>2</sup> + 5x 2.5 mm <sup>2</sup> , 1x 15-pin female hybrid connector	

Table 73: 8DIcde.ffggg0i00-1 - Order data

## 4.3.9 Technical data

### 4.3.9.1 General information

General information	
Module type	ACOPOSmotor module
Current-carrying capacity of 15-pin TYCO connector	
Power contacts	Max. 20 A at 40°C
Certifications	
CE	Yes
cULus	Yes <sup>1)</sup>
FSC	Yes <sup>1)</sup>
Support	
Software	
ACP10	V2.422 or higher
Thermal properties	
Cooling method per EN 60034-6 (IC code)	
Standard	Self-cooling, free circulation surface cooling (IC4A0A0)
With fan kit 8ZBDF installed	External cooling, surface cooling with machine-mounted independent fan component (IC4A0A6)
Operating conditions	
Type of construction and mounting arrangement per EN 60034-7 (IM code)	Horizontal, motor shaft aligned horizontally (IM 3001) Vertical, motor standing on the machine (IM 3011) Vertical, motor hanging on the machine (IM 3031) <sup>2)</sup>
Reduction of nominal current and stall current at installation elevations starting at 500 m above sea level	10% per 1,000 m
Reduction of continuous power at installation elevations starting at 500 m above sea level	10% per 1,000 m
Installation elevation above sea level	
Nominal	0 to 500 m
Maximum <sup>3)</sup>	4000 m
Pollution degree per EN 61800-5-1	2 (non-conductive pollution)
Overvoltage category per EN 61800-5-1	III
Degree of protection per EN 60529 <sup>4)</sup>	Without oil seal option: IP64 With oil seal option: IP65 With fan kit 8ZDFB installed: IP24
Ambient conditions	
Temperature	
Operation	
Nominal	5 to 40°C
Maximum	55°C <sup>5)</sup>
Storage	-25 to 55°C
Transport	-25 to 70°C
Max. flange temperature	65°C
Relative humidity	
Operation	5 to 85%, non-condensing
Storage	5 to 95%, non-condensing
Transport	Max. 95% at 40°C
Mechanical properties	
Motor coating	Water-based paint, RAL 2005 flat
Inverter coating	Electrophoretic deposition (EPD), black
Vibration severity per EN 60034-14	Vibration severity level A <sup>6)</sup>
Roller bearing, dynamic load rating and nominal service life	Based on DIN ISO 281
Shaft end per DIN 748	Form E
Oil seal per DIN 3760	Form A
Key and keyway per DIN 6885-1	Keyway form N1, key form A
Balancing of shaft per DIN ISO 8821	Shaft and fitment key convention
Mounting flange per DIN 42948	Form A
Radial runout, concentricity and axial runout of mounting flange per DIN 42955	Tolerance R

Table 74: Technical data

- 1) Revision C1 and later.
- 2) The IM3031 type of construction and mounting arrangement (vertical, motor hanging on the machine) must be avoided since production fluids or oils, e.g. from a gearbox, can penetrate the motor and damage it. If this is not possible, it is mandatory to select the oil seal option and to ensure that no production fluids or oils get onto the seal.
- 3) Continuous operation at an installation elevation of 500 m to 4,000 m above sea level is possible taking the specified reduction of continuous current into account. Requirements that go beyond this must be arranged with B&R.
- 4) The specified degree of protection is only met if all connectors on the module that are not being used are closed with suitable threaded caps or slot covers! Suitable threaded caps or slot covers are available as optional accessories (X67AC0M08, X67AC0M12, 8CX000.0000-00). The module is delivered with IP20 protection.
- 5) Continuous operation at an ambient temperature of 40°C to max. 55°C is possible taking the reduction of continuous torque into account, but this results in premature aging of components.
- 6) Vibration severity level B on request.

## 4.3.9.2 Inverter module

Product ID	8DIcde.ffggg7i00-1	8DIcde.ffggg0i00-1
<b>DC bus connection</b>		
Voltage		
Nominal	750 VDC	
Continuous power consumption <sup>1)</sup>	$(P_N/0.97) + P_{IM}$	
DC bus capacitance	Size 3 (8DI3x): 10 µF Size 4 (8DI4x): 15 µF Size 5 (8DI5x): 24 µF	
Design	19-pin hybrid connector <sup>2)</sup>	
Cable length		
Maximum	30 m	
<b>24 VDC power supply</b>		
Input voltage	24 VDC +20% / -25%	
Input capacitance	120 µF	
Max. power consumption	10 W + $P_{\text{HoldingBrake}}$ + $P_{24\text{ VDC Out }1}$ [0 ... 96 W] + $P_{24\text{ VDC Out }2}$ [0 ... 12 W]	
Design	19-pin hybrid connector <sup>2)</sup>	
Cable length		
Maximum	30 m	
<b>24 VDC Out 1</b>		
Output voltage	Depends on the 24 VDC supply	-
Continuous current	Max. 4 A	-
Fuse protection	Electronic	-
Design		
24 VDC	M8 connector	-
COM	M8 connector	-
Cable length		
Maximum	30 m	
<b>24 VDC Out 2</b>		
Output voltage	Depends on the 24 VDC supply	-
Continuous current	Max. 0.5 A	-
Fuse protection	Electronic	-
Design		
24 VDC	M12 connector	-
COM	M12 connector	-
Cable length		
Maximum	30 m	
<b>Motor connection</b>		
Nominal switching frequency	5 kHz	
Possible switching frequencies <sup>3)</sup>	5 / 10 / 20 kHz	
Max. output frequency	598 Hz <sup>4)</sup>	
<b>Motor holding brake connection</b>		
Quantity	1	
Continuous current	1 A	
Max. switching frequency	0.5 Hz	
Response threshold for undervoltage monitoring	24 VDC -25%	
<b>Fieldbus</b>		
Type	POWERLINK V1/V2 100BASE-T (ANSI/IEE 802.3)	
Design	Internal 2-port hub, 2x 19-pin male hybrid connector	Internal 3-port hub, 2x 19-pin hybrid connector, 1x M12 connector, female
Cable length	Max. 100 m between two stations (segment length) <sup>5)</sup>	
Transfer rate	100 Mbit/s	
<b>Enable inputs</b>		
Quantity	2	
Wiring	Sink	
Electrical isolation		
Input - Inverter module	Yes	
Input - Input	Yes	
Input voltage		
Nominal	24 VDC	
Maximum	30 VDC	
Input current at nominal voltage	60 mA	
Switching threshold		
Low	<5 V	
High	>15 V	
Switching delay at nominal input voltage		
Enable 1 → 0, PWM off	12 ms	
Enable 0 → 1, ready for PWM	1 ms	
Modulation compared to ground potential	Max. ±38 V	
Design	19-pin hybrid connector <sup>2)</sup>	
<b>Trigger inputs</b>		
Quantity	2	-
Wiring	Sink	-

Table 75: 8DIcde.ffggg7i00-1, 8DIcde.ffggg0i00-1 - Technical data

Product ID	8DIcde.ffggg7i00-1	8DIcde.ffggg0i00-1
Electrical isolation		
Input - Inverter module	No	-
Input - Input	No	-
Input voltage		
Nominal	24 VDC	-
Maximum	30 VDC	-
Switching threshold		
Low	<5 V	-
High	>15 V	-
Input current at nominal voltage	5 mA	-
Switching delay		
Rising edge	In preparation	-
Falling edge	In preparation	-
Modulation compared to ground potential	Max. ±38 V	-
Design	M12 connector	-
Cable length		
Maximum	30 m	
<b>Support</b>		
Software		
ACP10	V2.43 and higher	

Table 75: 8DIcde.ffggg7i00-1, 8DIcde.ffggg0i00-1 - Technical data

- Valid in the following conditions: 750 VDC DC bus voltage, 5 kHz switching frequency, 40°C ambient temperature, installation elevation <500 m above sea level, no derating due to cooling type.
- It is important to note that the 19-pin hybrid connector is designed for max. 20 connection cycles.
- B&R recommends operating the module at its nominal switching frequency. Operating the module at a higher switching frequency for application-specific reasons reduces the continuous current and increases the CPU load.
- The module's electrical output frequency (SCTRL\_SPEED\_ACT \* MOTOR\_POLEPAIRS) is monitored to protect against dual use in accordance with Council Regulation (EC) 428/2009 | 3A225. If the electrical output frequency of the module exceeds the limit value of 598 Hz uninterrupted for more than 0.5 s, then the current movement is aborted and error 6060 is output ("Power unit: Limit speed exceeded").
- Limited to 30 m when using hybrid cables.

### 4.3.9.3 Encoder

Description				
Order code (ff)	S8/D8	S9/D9	SA/DA	SB/DB
Can be used with	Size 3	Size 3	Sizes 4 and 5	Sizes 4 and 5
Encoder type	EnDat single-turn functional safety	EnDat multi-turn functional safety	EnDat single-turn functional safety	EnDat multi-turn functional safety
Operating principle	Inductive			
EnDat protocol	EnDat 2.2			
Position values per revolution	524,288 (19-bit)			
Distinguishable revolutions	---	4096 (12-bit)	---	4096 (12-bit)
Precision	±120"		±65"	
Vibration during operation 55 to 2,000 Hz	Stator: ≤400 m/s <sup>2</sup> , rotor: ≤600 m/s <sup>2</sup> (EN 60068-2-6) <sup>1)</sup>		Stator: ≤200 m/s <sup>2</sup> , rotor: ≤600 m/s <sup>2</sup> (IEC 60068-2-6) <sup>2)</sup>	
Shock during operation Duration 6 ms	≤2,000 m/s <sup>2</sup> (EN 60068-2-27)			
Manufacturer's website	Dr. Johannes Heidenhain GmbH <a href="http://www.heidenhain.de">www.heidenhain.de</a>			
Manufacturer's product ID	ECl 1119	EQI 1131	ECl 1319	EQI 1331

- Valid according to standard at room temperature,
  - 10 to 55 Hz, constant path, 4.9 mm peak to peak
  - 10 to 55 Hz, constant lift, 4.9 mm peak to peak
  - 10 to 55 Hz, constant amplitude, 4.9 mm peak to peak
- In accordance with the standard at room temperature; the following values apply at a working temperature up to 100°C: ≤300 m/s<sup>2</sup>, up to 115°C: ≤150 m/s<sup>2</sup>.
  - 10 to 55 Hz, constant path, 4.9 mm peak to peak
  - 10 to 55 Hz, constant lift, 4.9 mm peak to peak
  - 10 to 55 Hz, constant amplitude, 4.9 mm peak to peak

### 4.3.10 Size 3

#### 4.3.10.1 Technical data

Product ID	8DI33x.ff045hi00-1	8DI34x.ff045hi00-1
<b>Motor</b>		
Nominal speed $n_N$ [rpm]	4500	
Number of pole pairs	4	
Nominal torque $M_N$ [Nm]	1.17	1.52
Nominal power $P_N$ [W]	551	716
Nominal current $I_N$ [A]	1.08	1.39
Stall torque $M_0$ [Nm]	2.4	2.86
Stall current $I_0$ [A]	2.22	2.62
Maximum torque $M_{max}$ [Nm]	6.12	9.81
Maximum current $I_{max}$ [A]	5.67	9
Maximum speed $n_{max}$ [rpm]	6600	
Torque constant $K_T$ [Nm/A]	1.08	1.09
Voltage constant $K_E$ [V/1000 rpm]	65.97	
Stator resistance $R_{zph}$ [ $\Omega$ ]	4.81	3.9
Stator inductance $L_{zph}$ [mH]	19.81	16.5
Thermal time constant $t_{therm}$ [min]	34	38
Moment of inertia $J$ [kgcm <sup>2</sup> ]	0.95	1.2
Mass without brake $m$ [kg]	4.7	5.6

Table 76: 8DI33x.ff045hi00-1, 8DI34x.ff045hi00-1 - Technical data

Order number	8DI330.ff045hi00-1	8DI340.ff045hi00-1
<b>Motor</b>		
Nominal speed $n_N$ [rpm]	4500	
Number of pole pairs	4	
Nominal torque $M_N$ [Nm]	1.17	1.52
Nominal power $P_N$ [W]	551	716
Nominal current $I_N$ [A]	1.08	1.39
Stall torque $M_0$ [Nm]	2.4	2.86
Stall current $I_0$ [A]	2.22	2.62
Maximum torque $M_{max}$ [Nm]	6.12	9.81
Maximum current $I_{max}$ [A]	5.67	9
Maximum speed $n_{max}$ [rpm]	6600	
Torque constant $K_T$ [Nm/A]	1.08	1.09
Voltage constant $K_E$ [V/1000 rpm]	65.97	
Stator resistance $R_{zph}$ [ $\Omega$ ]	4.81	3.9
Stator inductance $L_{zph}$ [mH]	19.81	16.5
Thermal time constant $t_{therm}$ [min]	34	38
Moment of inertia $J$ [kgcm <sup>2</sup> ]	0.95	1.2
Weight without brake $m$ [kg]	4.7	5.6

Table 77: 8DI330.ff045hi00-1, 8DI340.ff045hi00-1 - Technical data

### 4.3.10.2 8DI33e.ffgghi00-I - Speed-torque characteristic curve

With 560 VDC DC bus voltage

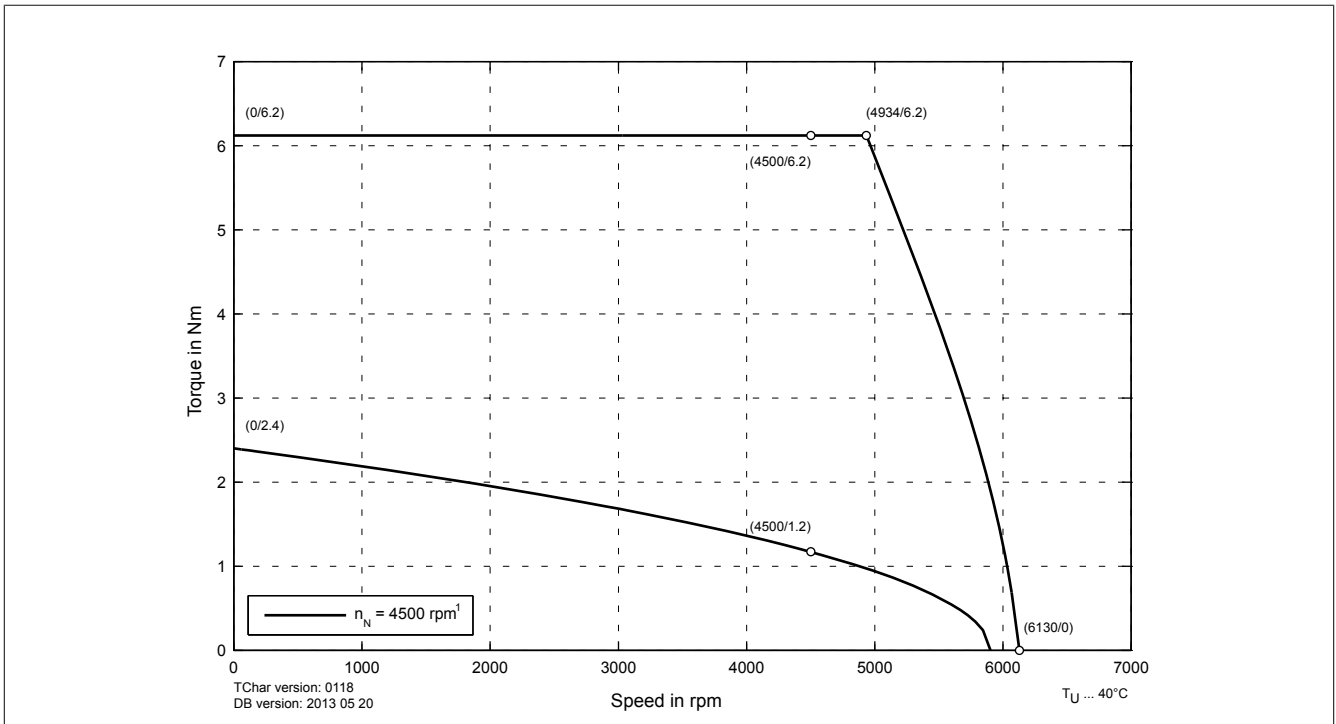

Figure 26: 8DI33e.ffgghi00-1 with 560 VDC DC bus voltage - Speed-torque characteristic curve

With 750 VDC DC bus voltage

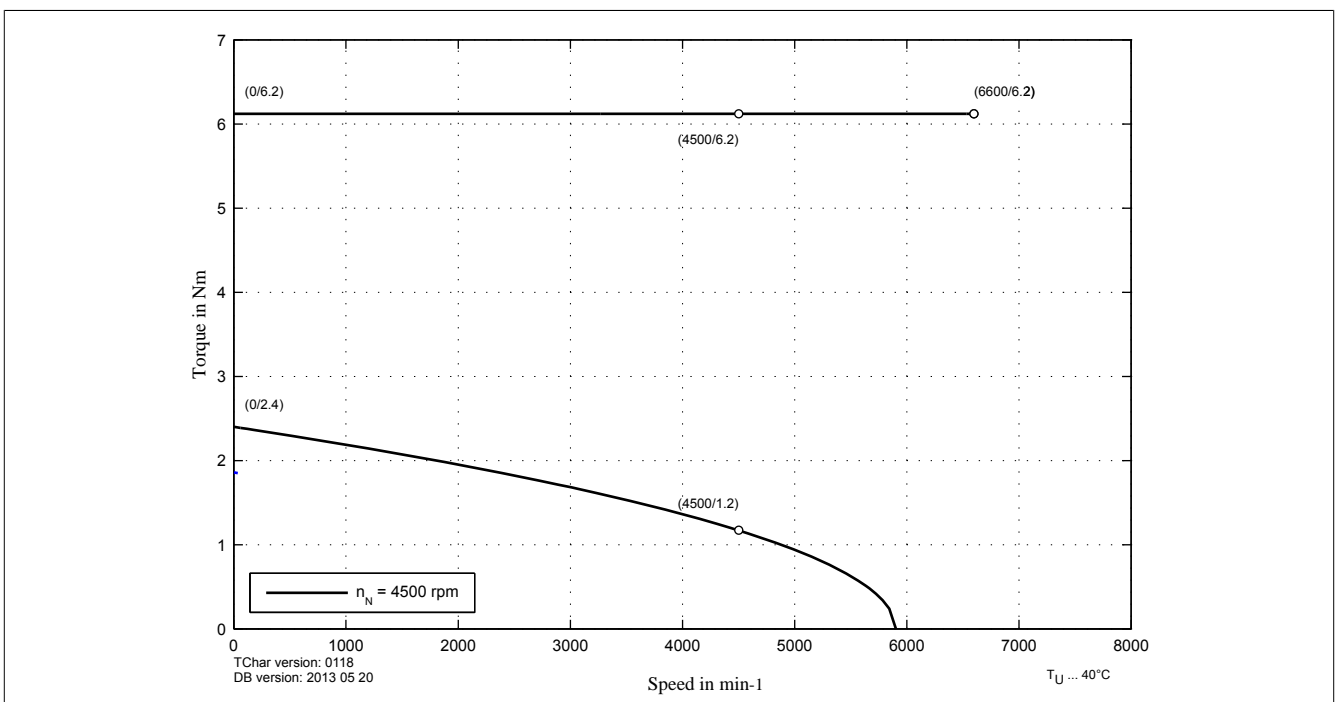

Figure 27: 8DI33e.ffgghi00-1 with 750 VDC DC bus voltage - Speed-torque characteristic curve

### 4.3.10.3 8DI34e.ffgghi00-1 - Speed-torque characteristic curve

With 560 VDC DC bus voltage

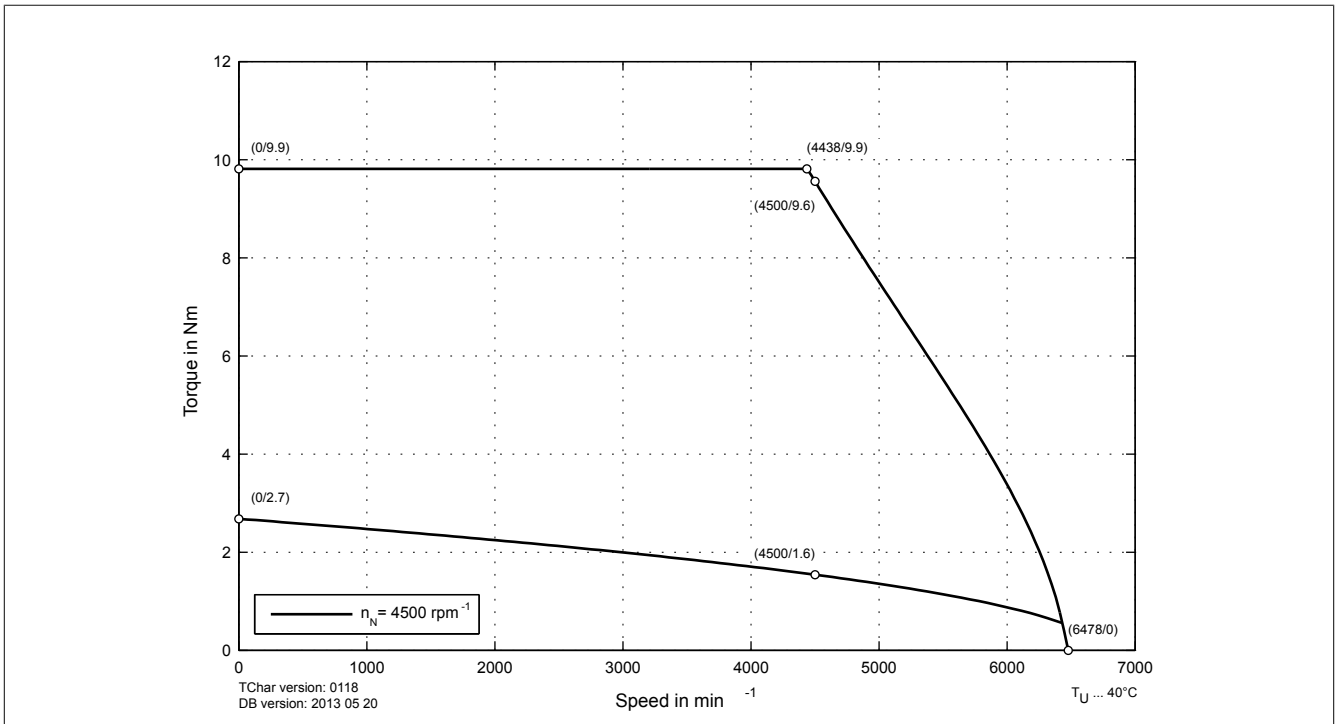

Figure 28: 8DI34e.ffgghi00-1 with 560 VDC DC bus voltage - Speed-torque characteristic curve

With 750 VDC DC bus voltage

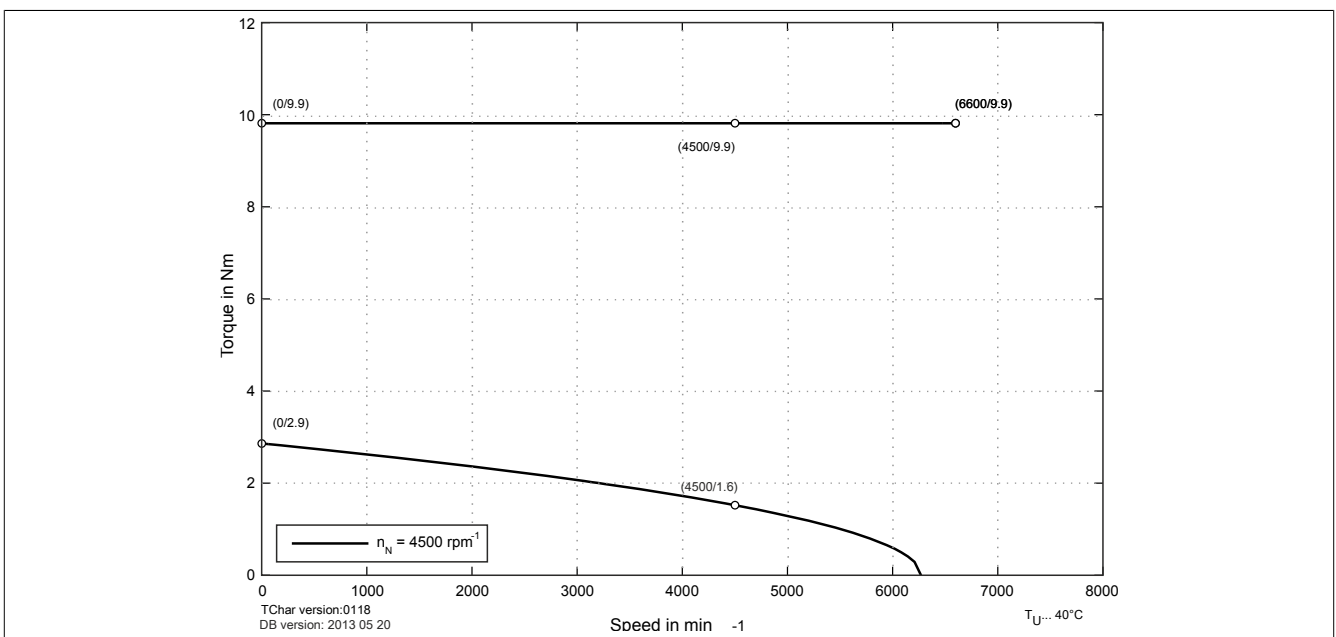
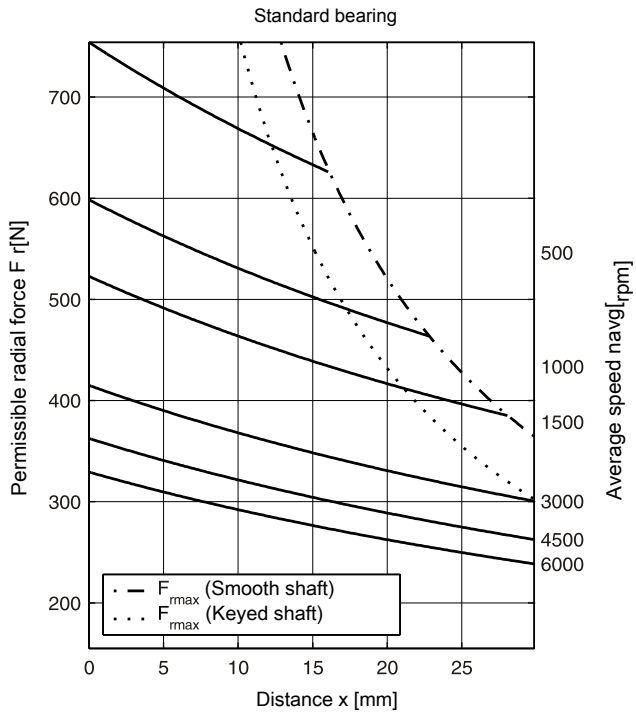

Figure 29: 8DI34e.ffgghi00-1 with 750 VDC DC bus voltage - Speed-torque characteristic curve

### 4.3.10.4 Maximum shaft load

The values in the diagram below are based on a mechanical service life of the bearings of 20,000 operating hours.



Maximum axial force:  $F_{amax} = 66 \text{ N}$

### 4.3.11 Size 4

#### 4.3.11.1 Technical data

Product ID	8DI44x.ff022hi00-1	8DI45x.ff022hi00-1	8DI46x.ff022hi00-1
<b>Motor</b>			
Nominal speed $n_N$ [rpm]	2200		
Number of pole pairs	5		
Nominal torque $M_N$ [Nm]	5	5.1	5.2
Nominal power $P_N$ [W]	1037	1175	1198
Nominal current $I_N$ [A]	2.26	2.4	2.35
Stall torque $M_0$ [Nm]	5.7	6.7	7.7
Stall current $I_0$ [A]	2.57	3.02	3.49
Maximum torque $M_{max}$ [Nm]	20.5	27.4	31.1
Maximum current $I_{max}$ [A]	14.46	19.29	21
Maximum speed $n_{max}$ [rpm]	12000		
Torque constant $K_T$ [Nm/A]	2.22		
Voltage constant $K_E$ [V/1000 rpm]	134.04		
Stator resistance $R_{zph}$ [ $\Omega$ ]	6.24	4.32	3.61
Stator inductance $L_{zph}$ [mH]	44.8	41	32
Electrical time constant $t_{el}$ [ms]	In preparation	9.49	8.86
Thermal time constant $t_{therm}$ [min]	30	35	40
Moment of inertia $J$ [kgcm <sup>2</sup> ]	2.73	3.58	4.39
Mass without brake $m$ [kg]	5.26	6.7	8.1

Table 78: 8DI44x.ff022hi00-1, 8DI45x.ff022hi00-1, 8DI46x.ff022hi00-1 - Technical data

Order number	8DI440.ff022hi00-1	8DI450.ff022hi00-1	8DI460.ff022hi00-1
<b>Motor</b>			
Nominal speed $n_N$ [rpm]	2200		
Number of pole pairs	5		
Nominal torque $M_N$ [Nm]	5	5.1	5.2
Nominal power $P_N$ [W]	1037	1175	1198
Nominal current $I_N$ [A]	2.26	2.4	2.35
Stall torque $M_0$ [Nm]	5.7	6.7	7.7
Stall current $I_0$ [A]	2.57	3.02	3.49
Maximum torque $M_{max}$ [Nm]	20.5	27.4	31.1
Maximum current $I_{max}$ [A]	14.46	19.29	21
Maximum speed $n_{max}$ [rpm]	12000		
Torque constant $K_T$ [Nm/A]	2.22		
Voltage constant $K_E$ [V/1000 rpm]	134.04		
Stator resistance $R_{zph}$ [ $\Omega$ ]	6.24	4.32	3.61
Stator inductance $L_{zph}$ [mH]	44.8	41	32
Electrical time constant $t_{el}$ [ms]	In preparation	9.49	8.86
Thermal time constant $t_{therm}$ [min]	30	35	40
Moment of inertia $J$ [kgcm <sup>2</sup> ]	2.73	3.58	4.39
Weight without brake $m$ [kg]	5.26	6.7	8.1

Table 79: 8DI440.ff022hi00-1, 8DI450.ff022hi00-1, 8DI460.ff022hi00-1 - Technical data

4.3.11.2 Speed-torque characteristic curve with 560 VDC DC bus voltage

8DI44e.ffggghi00-1

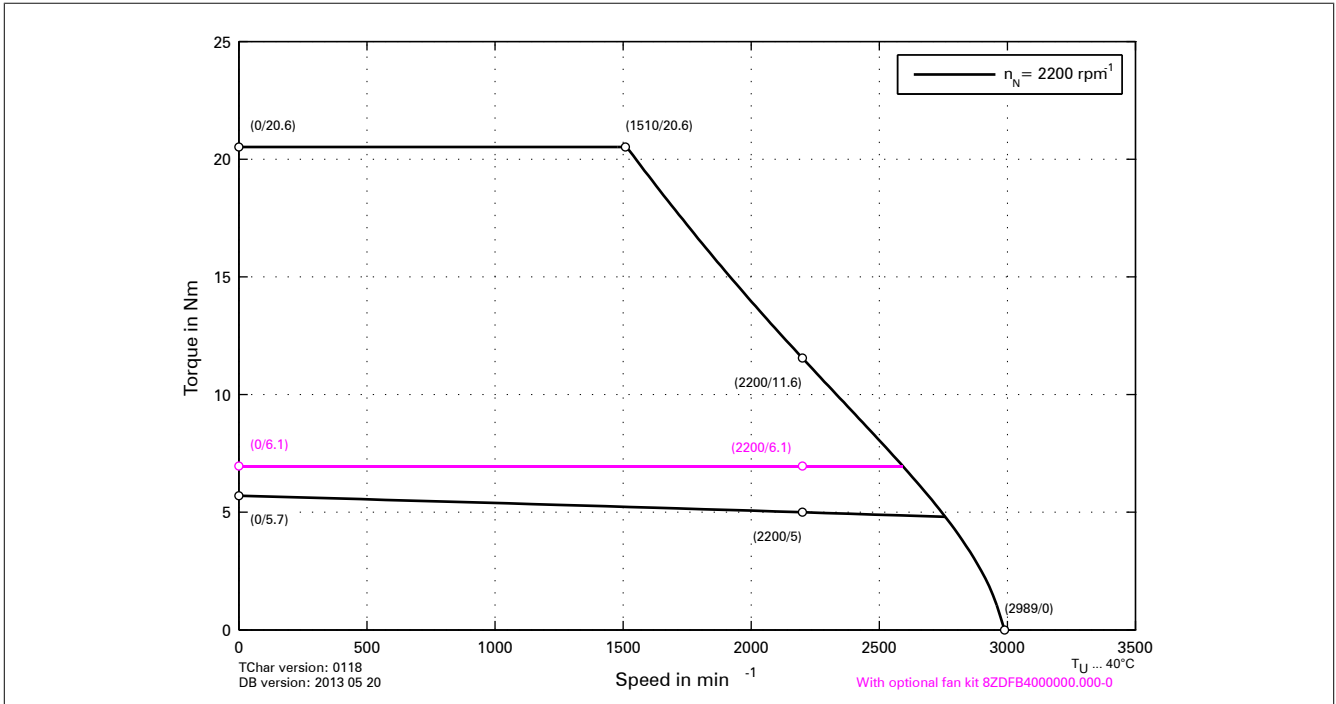

Figure 30: 8DI44e.ffggghi00-1 - Speed-torque characteristic curve

8DI45e.ffggghi00-1

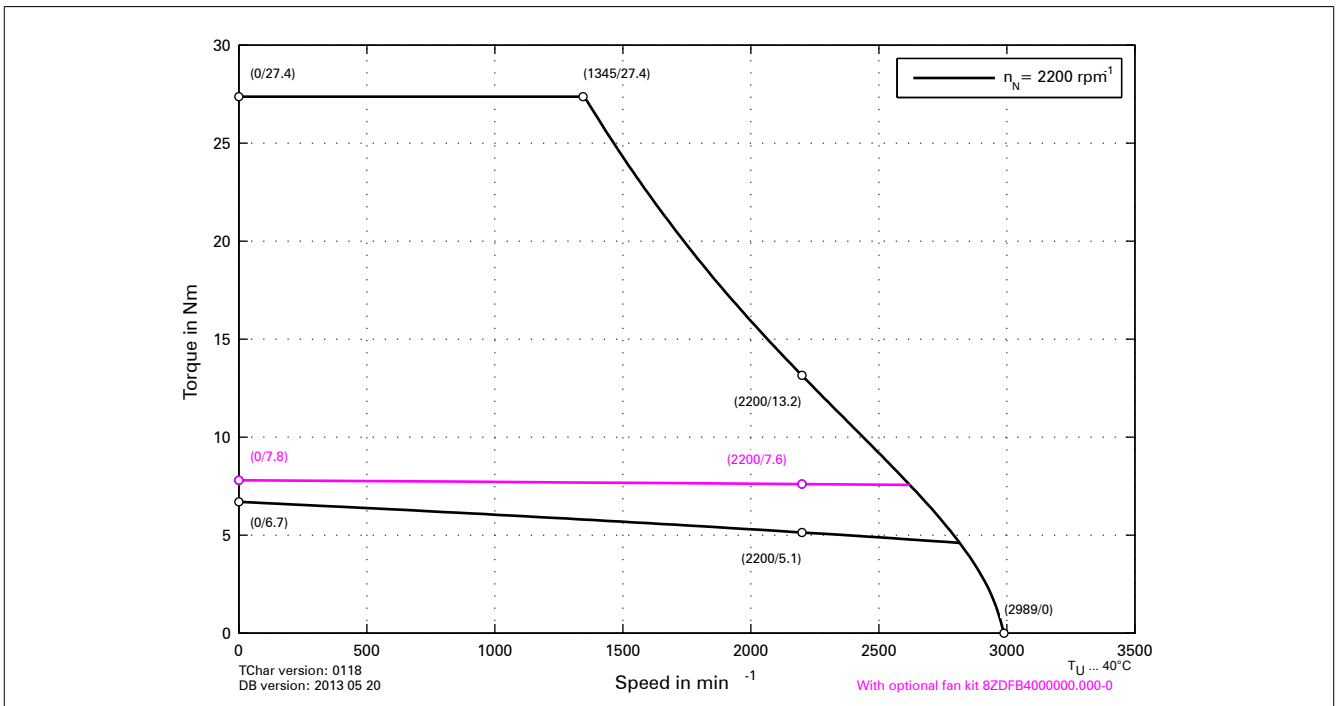

Figure 31: 8DI45e.ffggghi00-1 - Speed-torque characteristic curve

8DI46e.ffgghi00-1

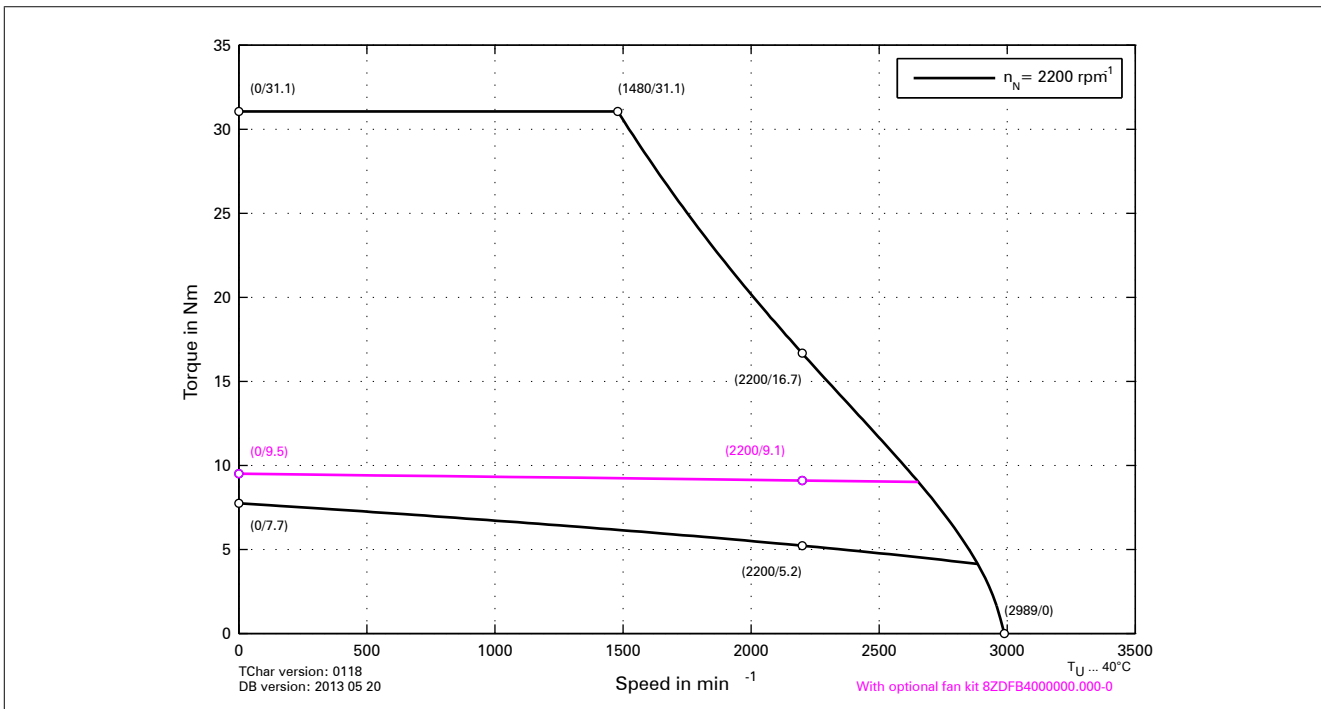

Figure 32: 8DI46e.ffgghi00-1 - Speed-torque characteristic curve

4.3.11.3 Speed-torque characteristic curve with 750 VDC DC bus voltage

8DI44e.ffgghi00-1

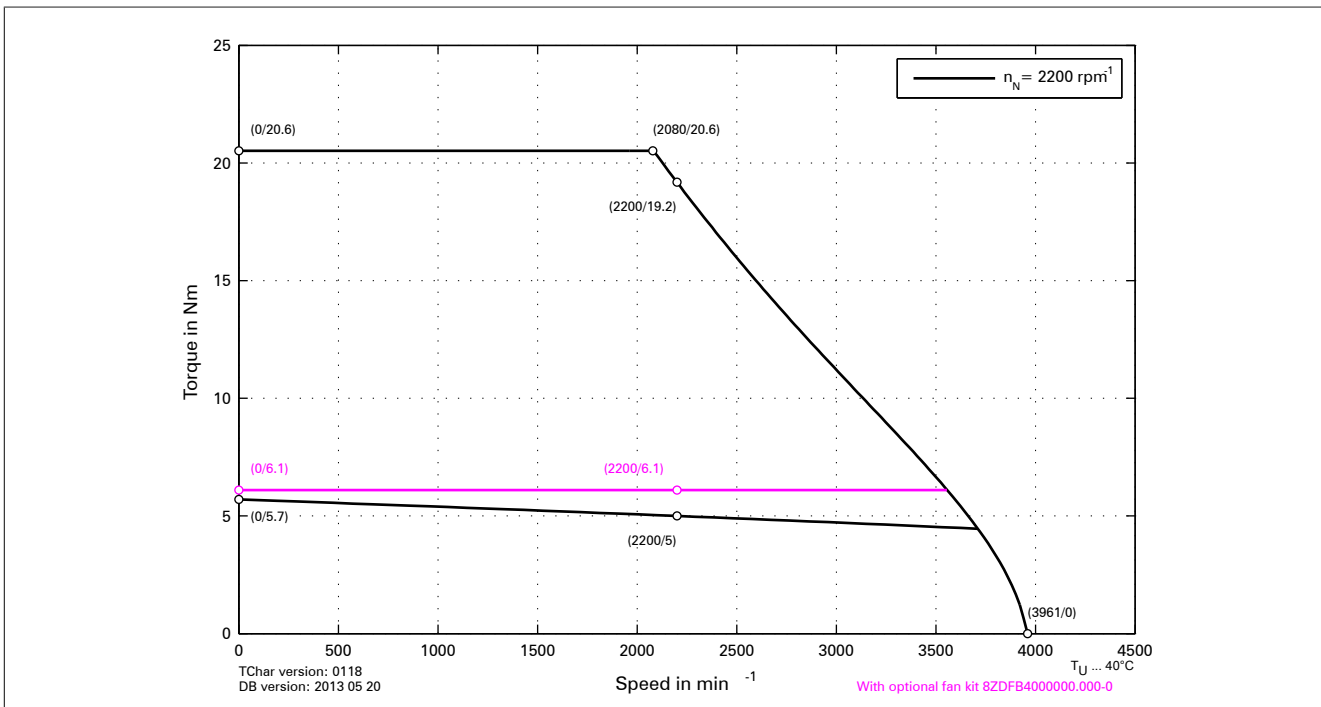

Figure 33: 8DI44e.ffgghi00-1 - Speed-torque characteristic curve

8DI45e.ffggghi00-1

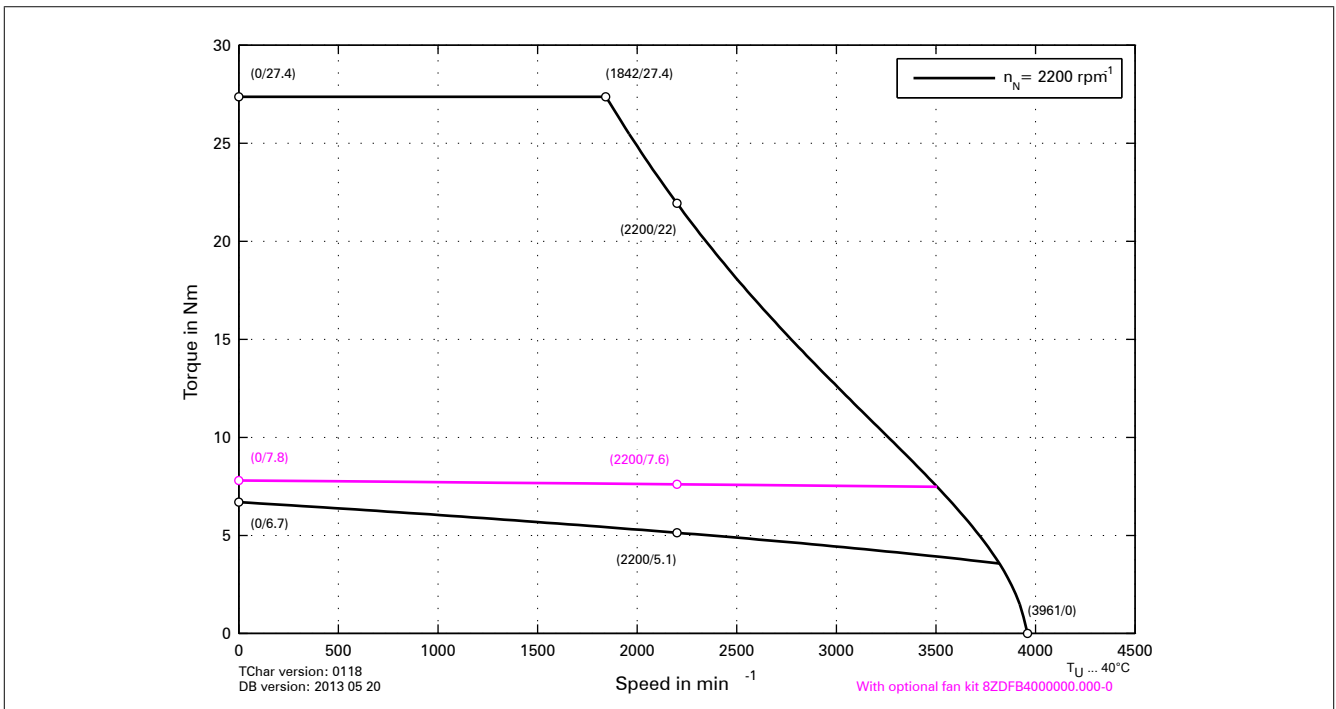

Figure 34: 8DI45e.ffggghi00-1 - Speed-torque characteristic curve

8DI46e.ffggghi00-1

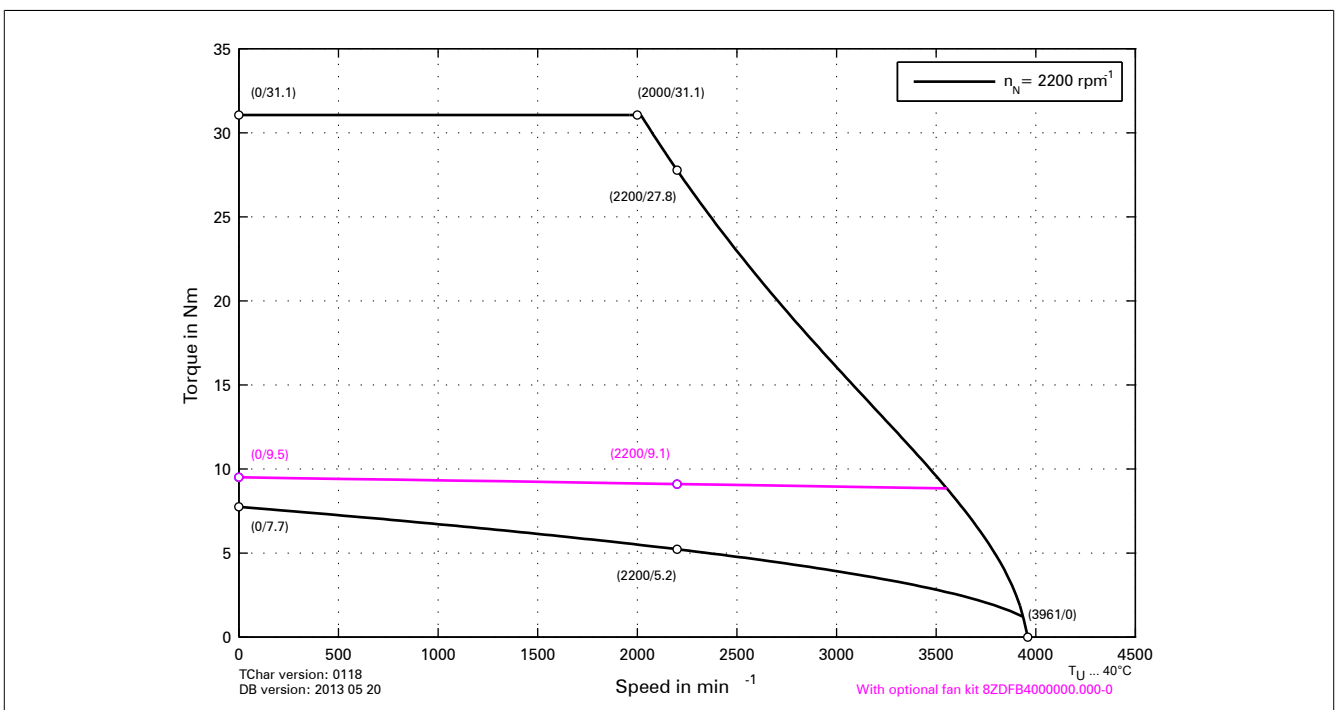
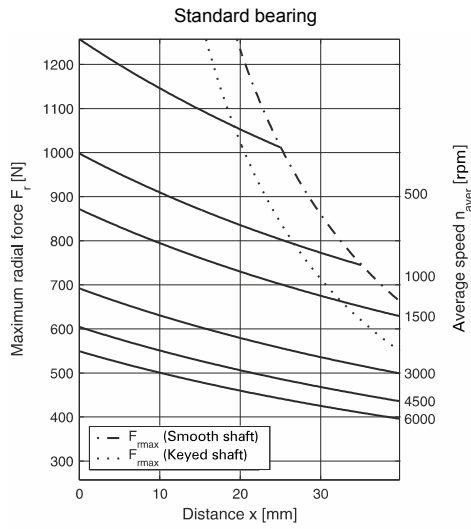

Figure 35: 8DI46e.ffggghi00-1 - Speed-torque characteristic curve

4.3.11.4 Maximum shaft load

The values in the diagram below are based on a mechanical service life of the bearings of 20,000 operating hours.



Maximum allowed axial force:  $F_{amax} = 110$  N

### 4.3.12 Size 5

#### 4.3.12.1 Technical data

Product ID	8DI54x.ff022hi00-1	8DI55x.ff022hi00-1	8DI56x.ff022hi00-1
<b>Motor</b>			
Nominal speed $n_N$ [rpm]	2200		
Number of pole pairs	4		
Nominal torque $M_N$ [Nm]	7.1	8.4	10
Nominal power $P_N$ [W]	1636	1935	2304
Nominal current $I_N$ [A]	3.2	3.79	4.51
Stall torque $M_0$ [Nm]	8	10	12
Stall current $I_0$ [A]	3.61	4.51	5.42
Maximum torque $M_{max}$ [Nm]	21.6	36.5	46.6
Maximum current $I_{max}$ [A]	14.9	21	
Maximum speed $n_{max}$ [rpm]	9000		
Torque constant $K_T$ [Nm/A]	2.22		
Voltage constant $K_E$ [V/1000 rpm]	134.04		
Stator resistance $R_{zph}$ [ $\Omega$ ]	3.44	2.265	1.51
Stator inductance $L_{zph}$ [mH]	34.5	24.29	17.6
Electrical time constant $t_{el}$ [ms]	10	10.724	In preparation
Thermal time constant $t_{therm}$ [min]	37	40	48
Moment of inertia $J$ [kgcm <sup>2</sup> ]	6.04	8.19	10
Mass without brake $m$ [kg]	11.46	13.29	16.4

Table 80: 8DI54x.ff022hi00-1, 8DI55x.ff022hi00-1, 8DI56x.ff022hi00-1 - Technical data

Order number	8DI540.ff022hi00-1	8DI550.ff022hi00-1	8DI560.ff022hi00-1
<b>Motor</b>			
Nominal speed $n_N$ [rpm]	2200		
Number of pole pairs	4		
Nominal torque $M_N$ [Nm]	7.1	8.4	10
Nominal power $P_N$ [W]	1636	1935	2304
Nominal current $I_N$ [A]	3.2	3.79	4.51
Stall torque $M_0$ [Nm]	8	10	12
Stall current $I_0$ [A]	3.61	4.51	5.42
Maximum torque $M_{max}$ [Nm]	21.6	36.5	46.6
Maximum current $I_{max}$ [A]	14.9	21	
Maximum speed $n_{max}$ [rpm]	9000		
Torque constant $K_T$ [Nm/A]	2.22		
Voltage constant $K_E$ [V/1000 rpm]	134.04		
Stator resistance $R_{zph}$ [ $\Omega$ ]	3.44	2.265	1.51
Stator inductance $L_{zph}$ [mH]	34.5	24.29	17.6
Electrical time constant $t_{el}$ [ms]	10	10.724	In preparation
Thermal time constant $t_{therm}$ [min]	37	40	48
Moment of inertia $J$ [kgcm <sup>2</sup> ]	6.04	8.19	10
Weight without brake $m$ [kg]	11.46	13.29	16.4

Table 81: 8DI540.ff022hi00-1, 8DI550.ff022hi00-1, 8DI560.ff022hi00-1 - Technical data

### 4.3.12.2 Speed-torque characteristic curve with 560 VDC DC bus voltage

#### 8DI54e.ffggghi00-1

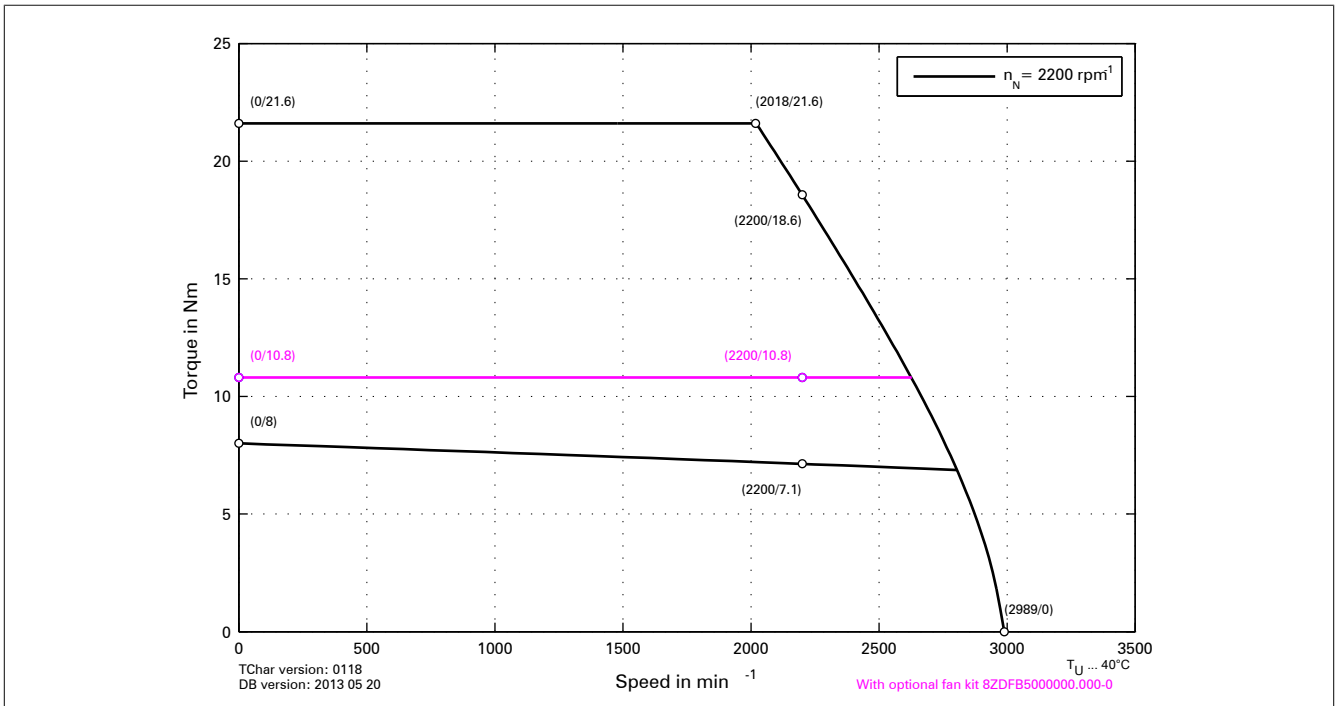

Figure 36: 8DI54e.ffggghi00-1 - Speed-torque characteristic curve

#### 8DI55e.ffggghi00-1

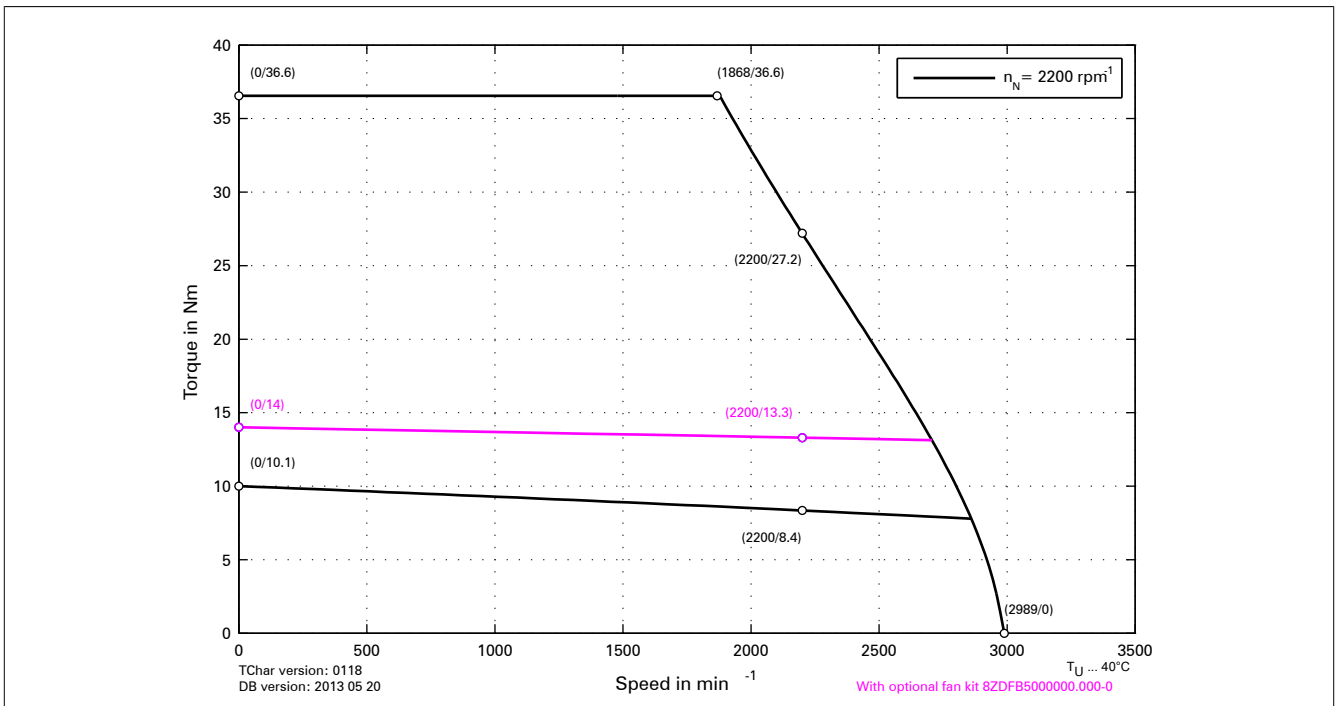

Figure 37: 8DI55e.ffggghi00-1 - Speed-torque characteristic curve

8DI56e.ffggghi00-1

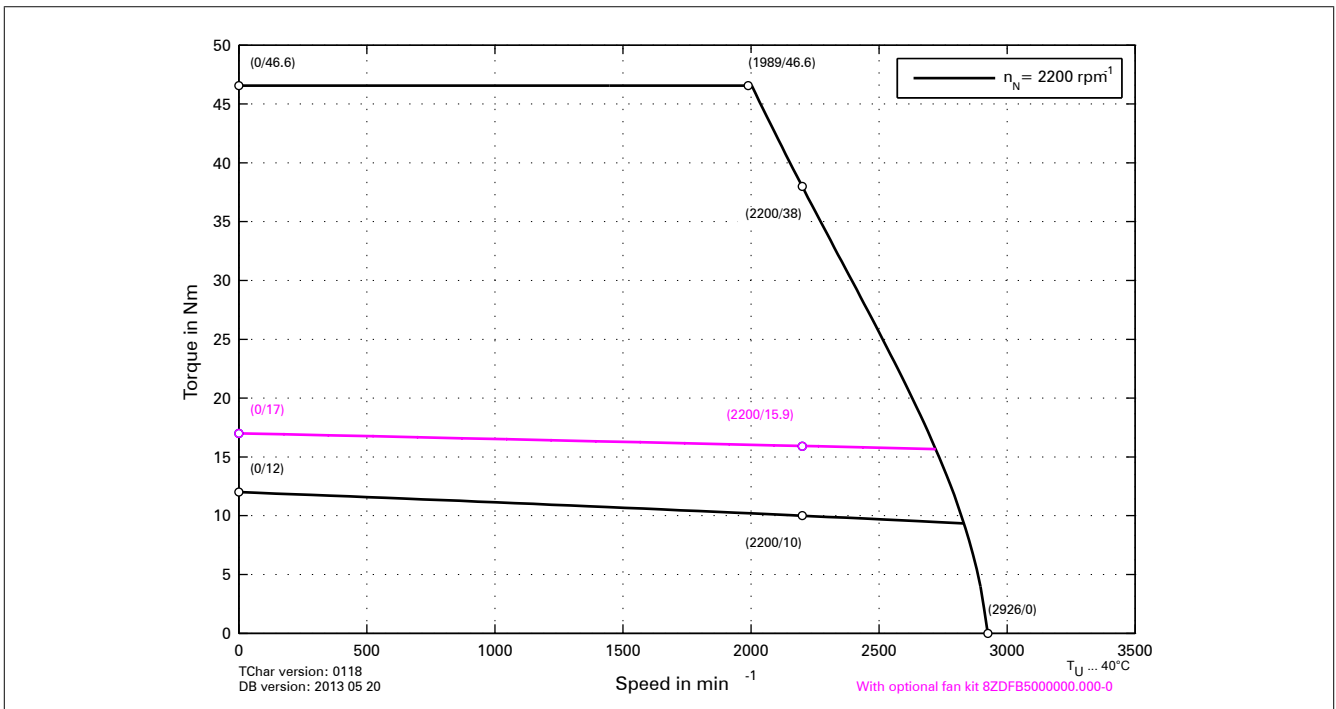

Figure 38: 8DI56e.ffggghi00-1 - Speed-torque characteristic curve

4.3.12.3 Speed-torque characteristic curve with 750 VDC DC bus voltage

8DI54e.ffggghi00-1

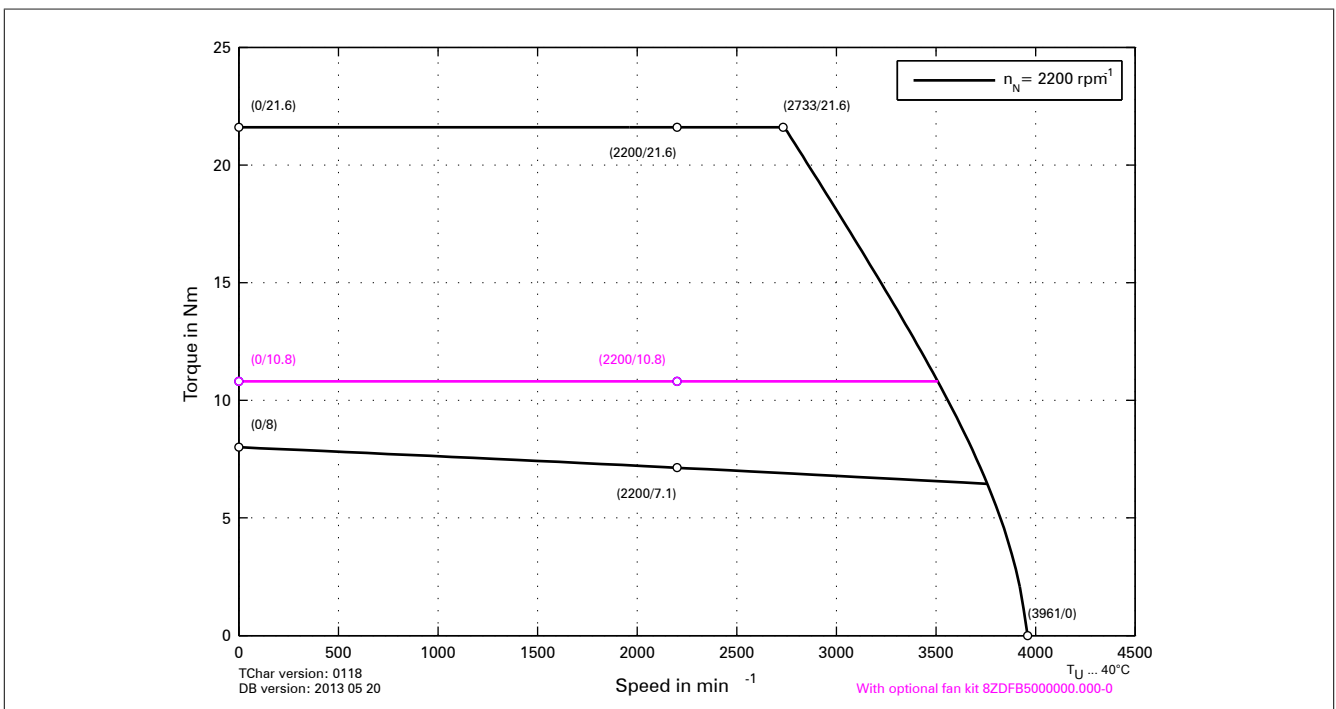

Figure 39: 8DI54e.ffggghi00-1 - Speed-torque characteristic curve

8DI55e.fggghi00-1

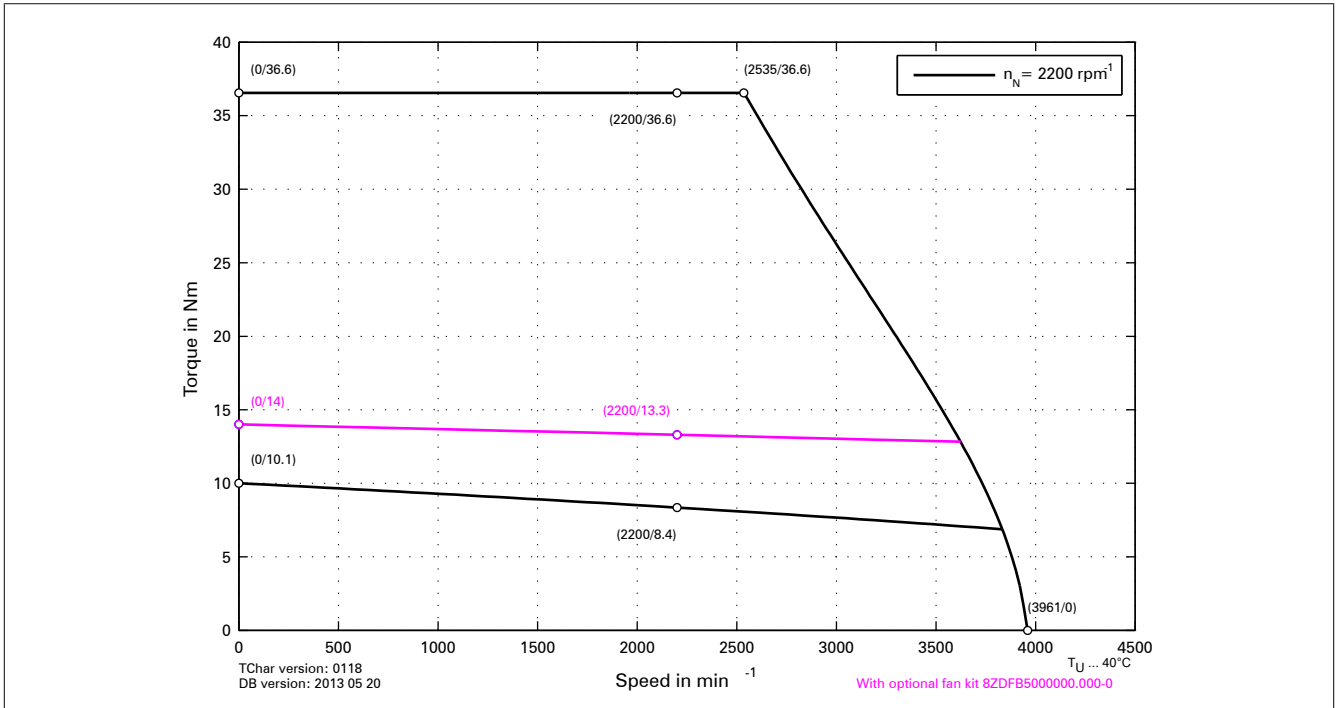

Figure 40: 8DI55e.fggghi00-1 - Speed-torque characteristic curve

8DI56e.fggghi00-1

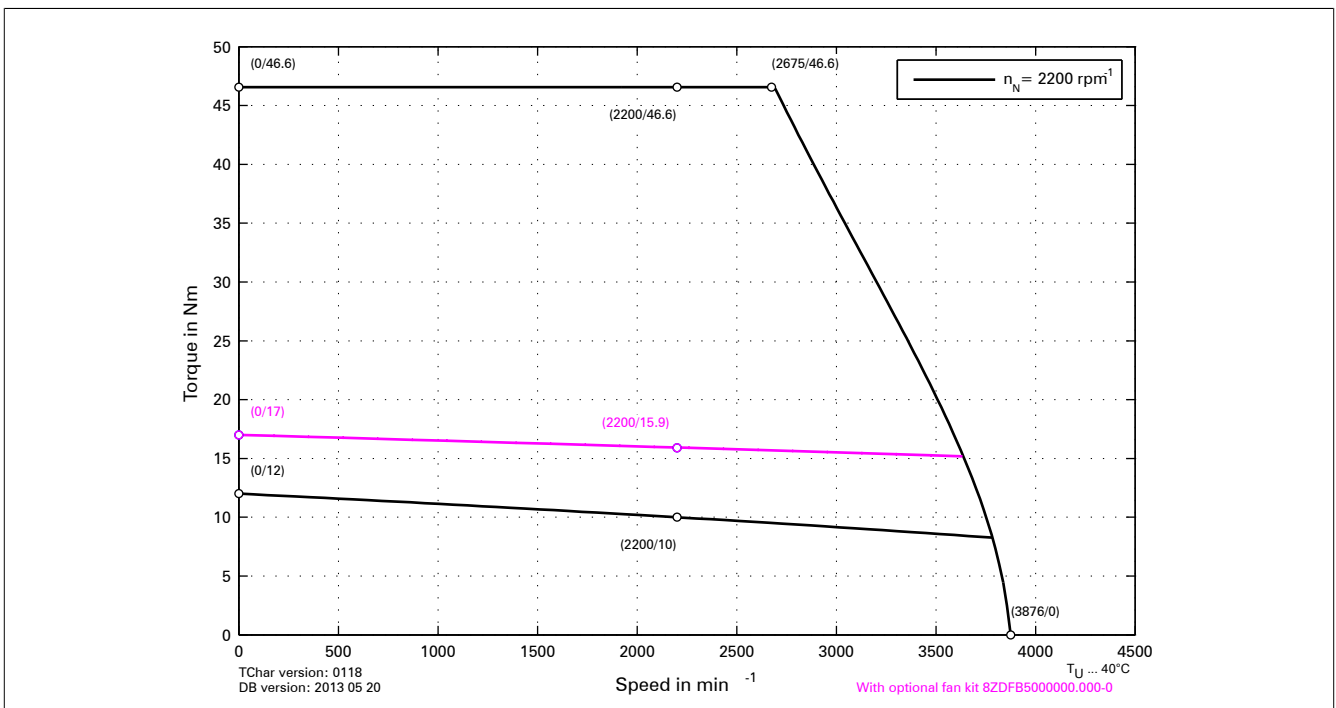
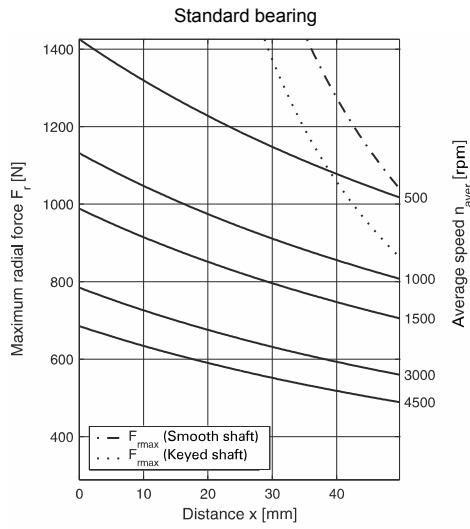

Figure 41: 8DI56e.fggghi00-1 - Speed-torque characteristic curve

4.3.12.4 Maximum shaft load

The values in the diagram below are based on a mechanical service life of the bearings of 20,000 operating hours.



Maximum allowed axial force:  $F_{amax} = 124$  N

### 4.3.13 Dimension diagrams and installation dimensions

#### 4.3.13.1 Size 3

#### 8DI3de.ffggg7i00-1

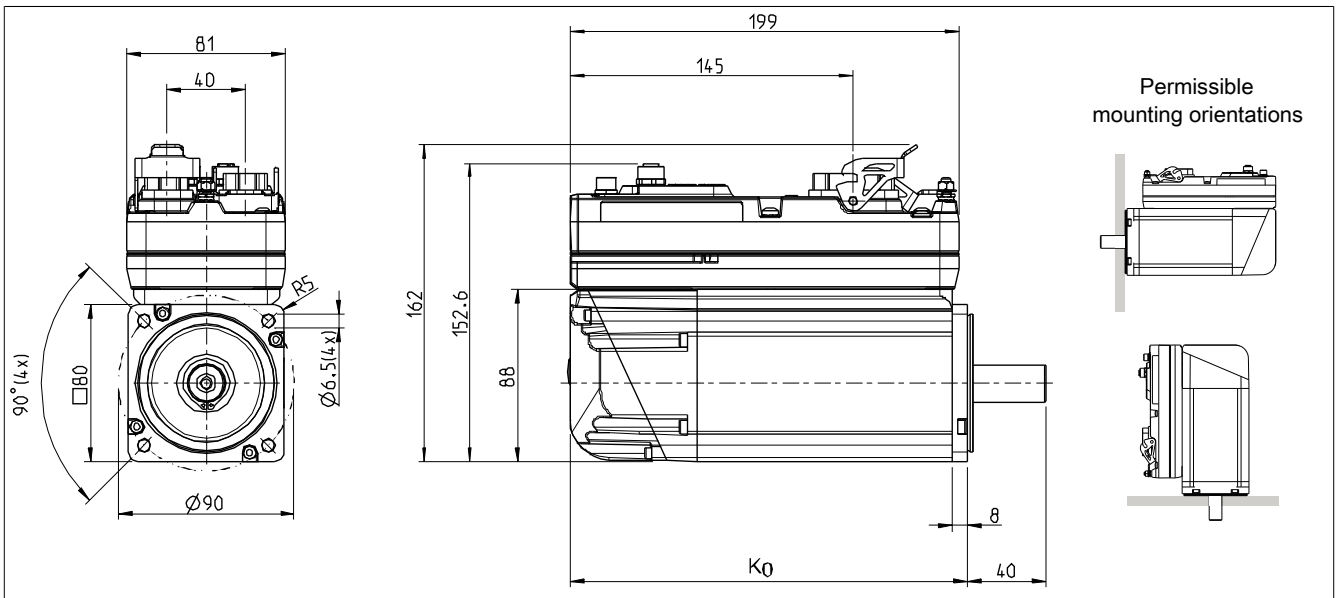

Figure 42: 8DI3en.ffggg7i00-1 - Dimension diagrams and installation dimensions

8DI3de.ffggg0i00-1

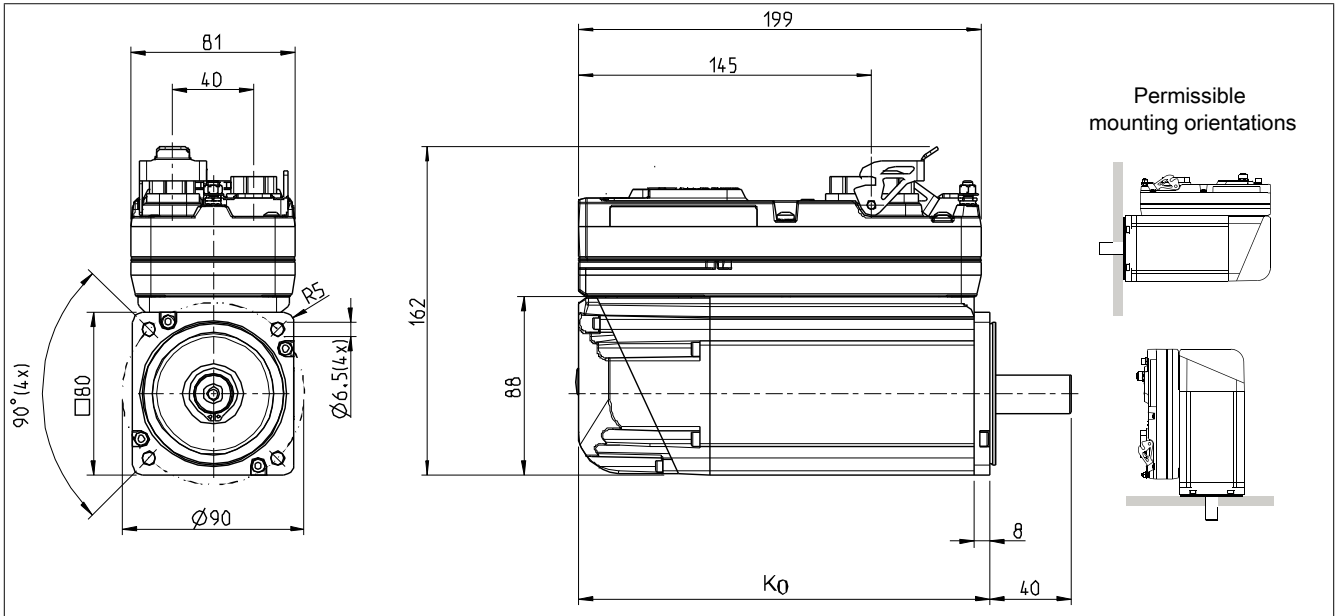

Figure 43: 8DI3de.ffggg0i00-1 - Dimension diagrams and installation dimensions

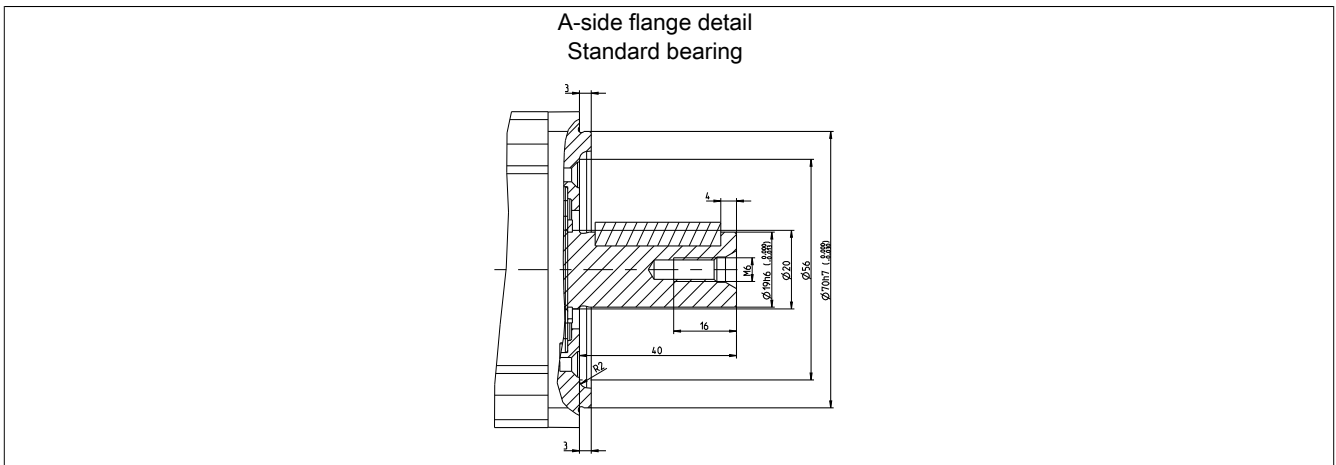
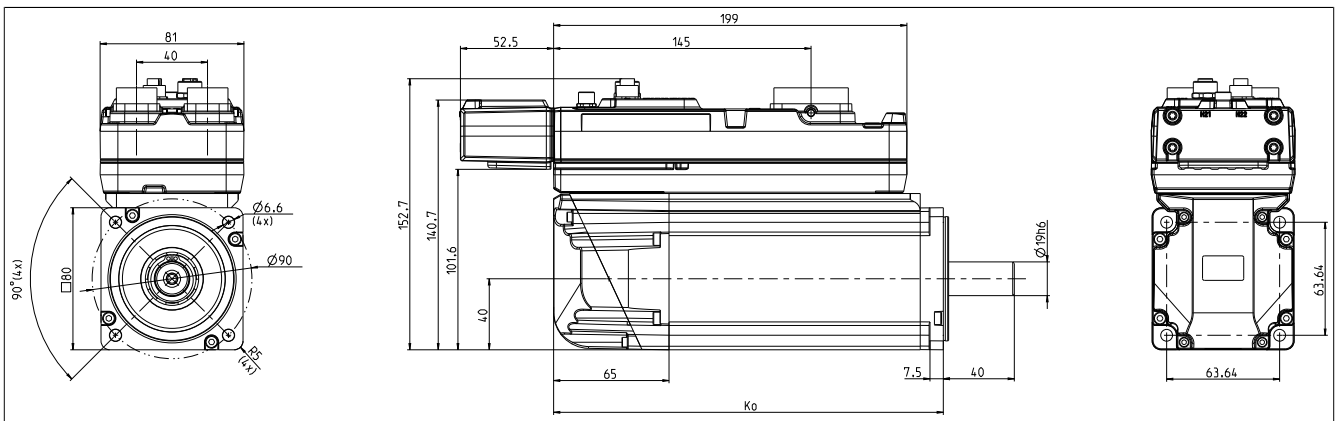

Figure 44: Flange details

ACOPOSmotor module	Length $K_0$ [mm]	Extension of $K_0$ depending on motor option [mm]	
		Holding brake	Oil seal
8DI33x.xxxxxxxxxx-x	203.5	27	5
8DI34x.xxxxxxxxxx-x	214.5	31	5

4.3.13.2 SafeMOTION - Size 3

8DI3dS.ffggghi00-1



A-side flange detail  
Standard bearing

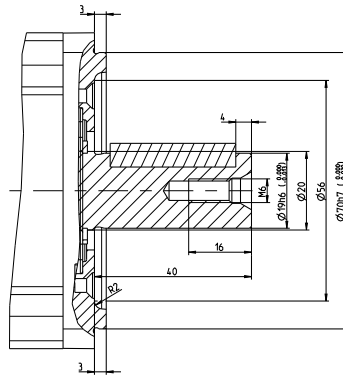

Figure 45: Flange details

ACOPOSmotor module	Length $K_0$ [mm]	Extension of $K_0$ depending on motor option [mm]	
		Holding brake	Oil seal
8DI33x.xxxxxxxx-x	203.5	27	5
8DI34x.xxxxxxxx-x	214.5	31	5

4.3.13.3 Size 4

8DI4de.ffggg7i00-1

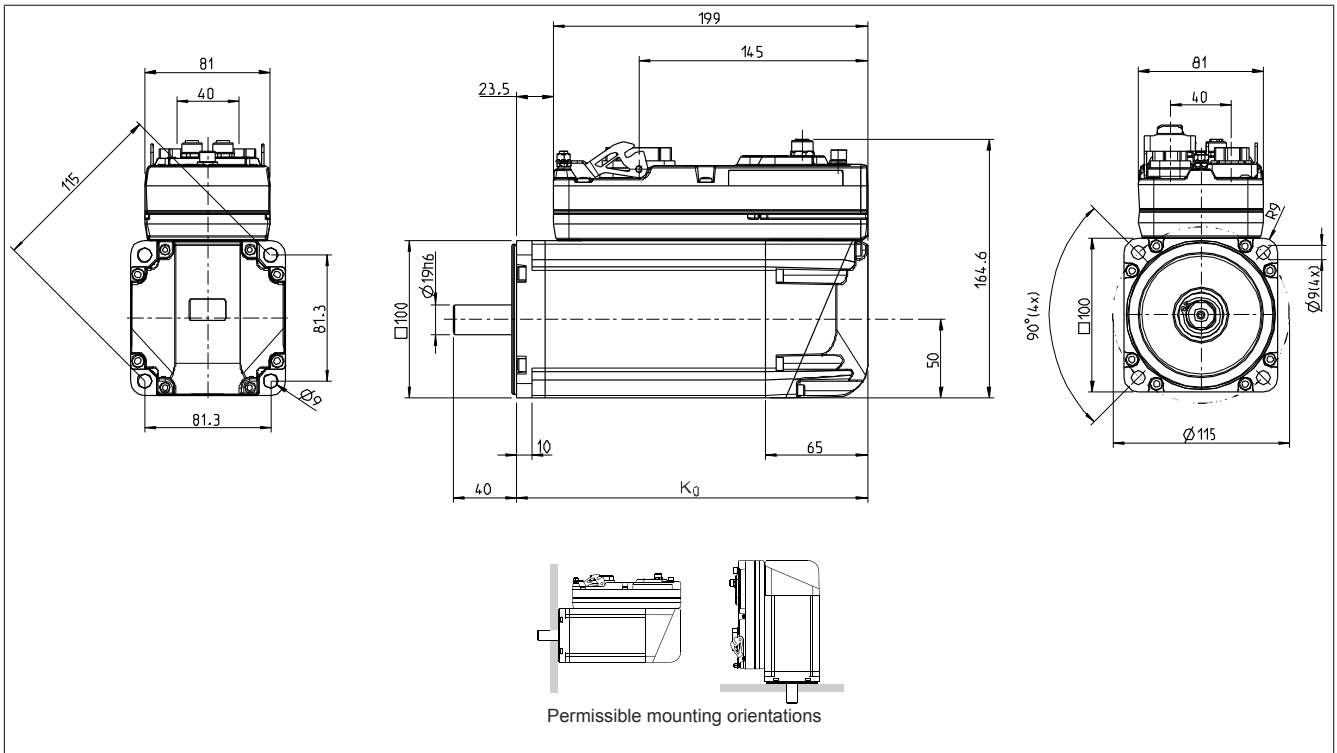

Figure 46: 8DI4de.ffggg7i00-1 - Dimension diagrams and installation dimensions

8DI4de.ffggg0i00-1

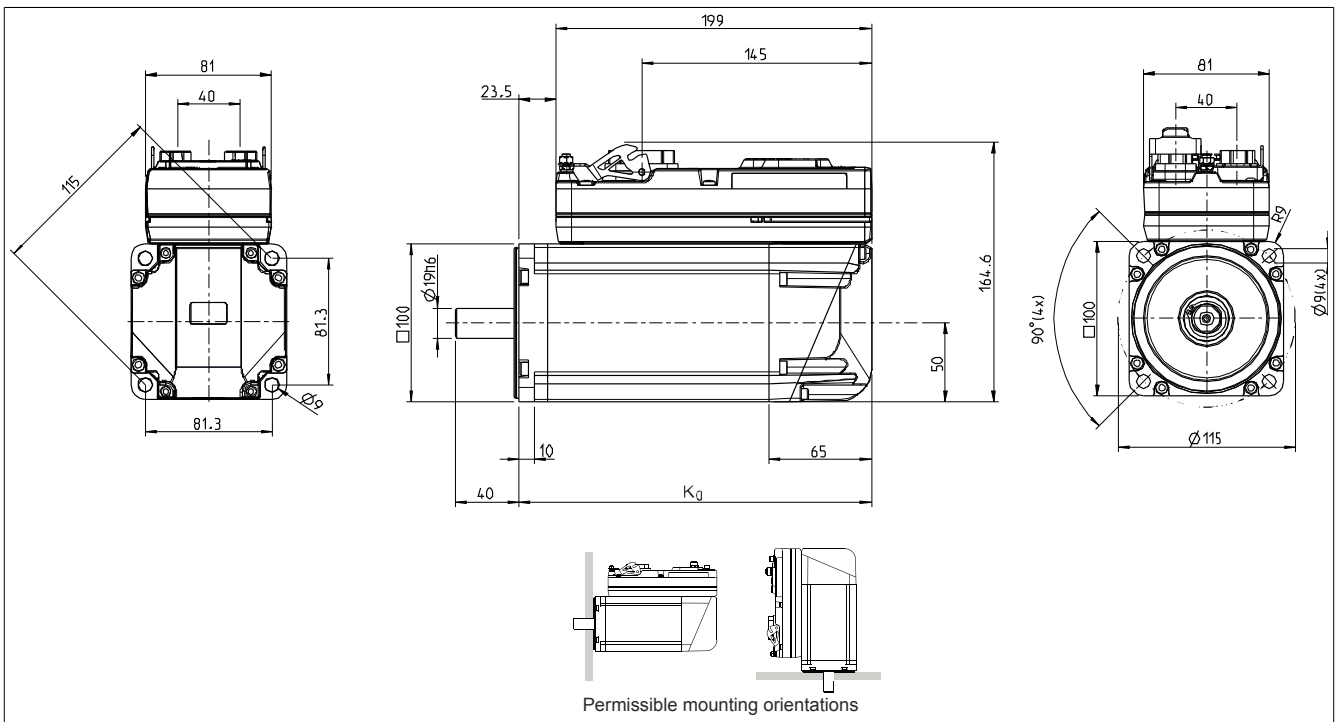

Figure 47: 8DI4de.ffggg0i00-1 - Dimension diagrams and installation dimensions

With optional fan kit 8ZDFB400000.000-0

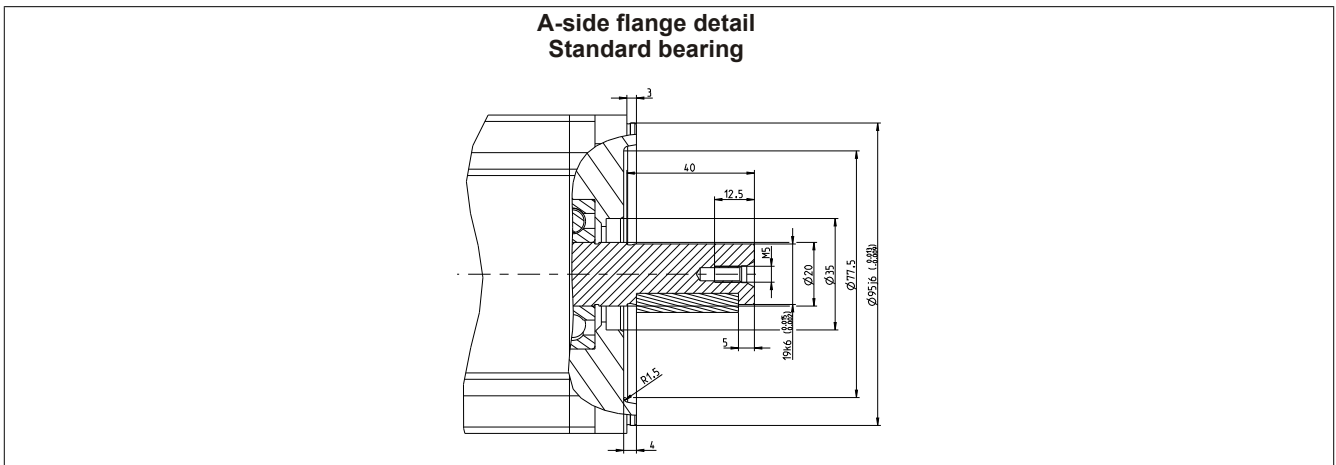
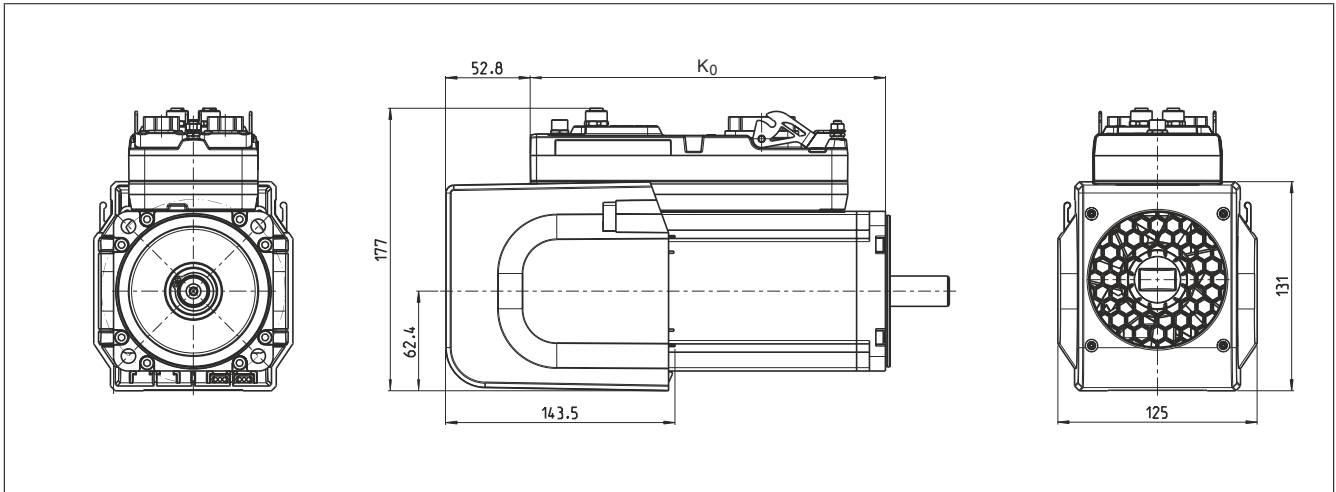
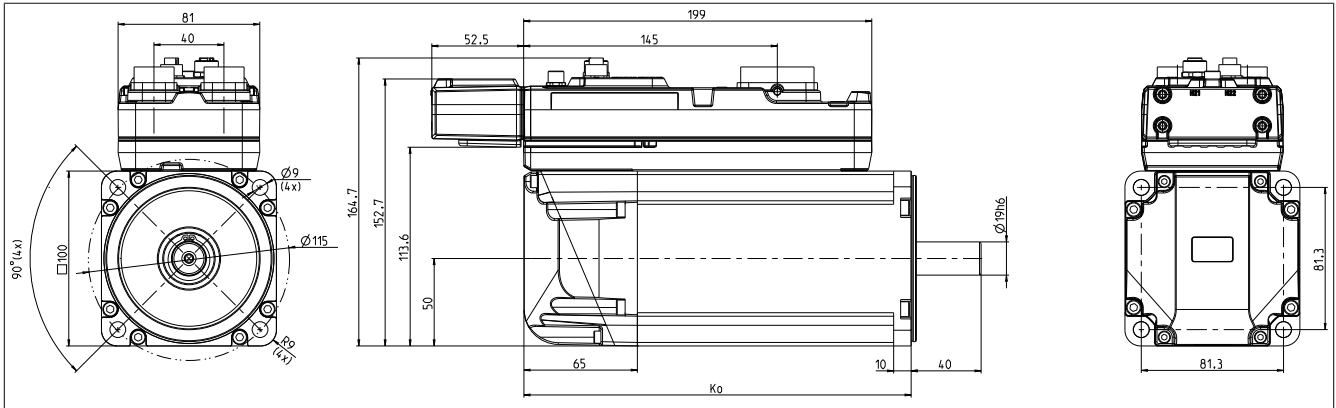

Figure 48: Flange details

Model number	K <sub>0</sub>	Extension of K <sub>0</sub> depending on motor option [mm]	
		Holding brake	Oil seal
8DI44x.Dxggghi00-1	222.5	32	---
8DI45x.Dxggghi00-1	246.5	32	---
8DI46x.Dxggghi00-1	266.5	32	---

4.3.13.4 SafeMOTION - Size 4

8DI4dS.ffggghi00-1



With optional fan kit 8ZDFB400000.000-0

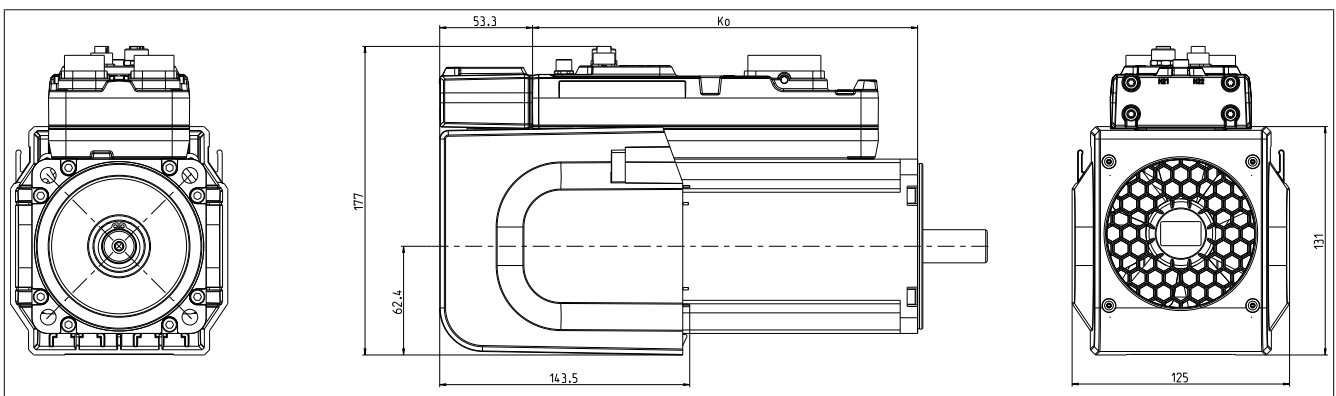

A-side flange detail  
Standard bearing

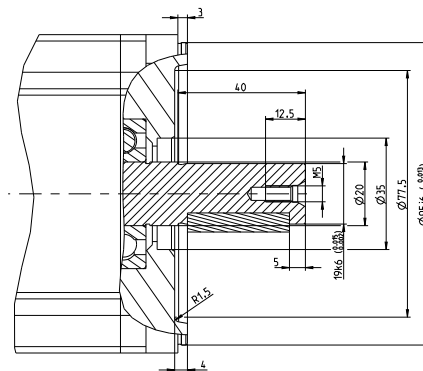

Figure 49: Flange details

Model number	K <sub>0</sub>	Extension of K <sub>0</sub> depending on motor option [mm]	
		Holding brake	Oil seal
8DI44x.Dxggghi00-1	222.5	32	---
8DI45x.Dxggghi00-1	246.5	32	---
8DI46x.Dxggghi00-1	266.5	32	---

4.3.13.5 Size 5

8DI5de.ffggg7i00-1

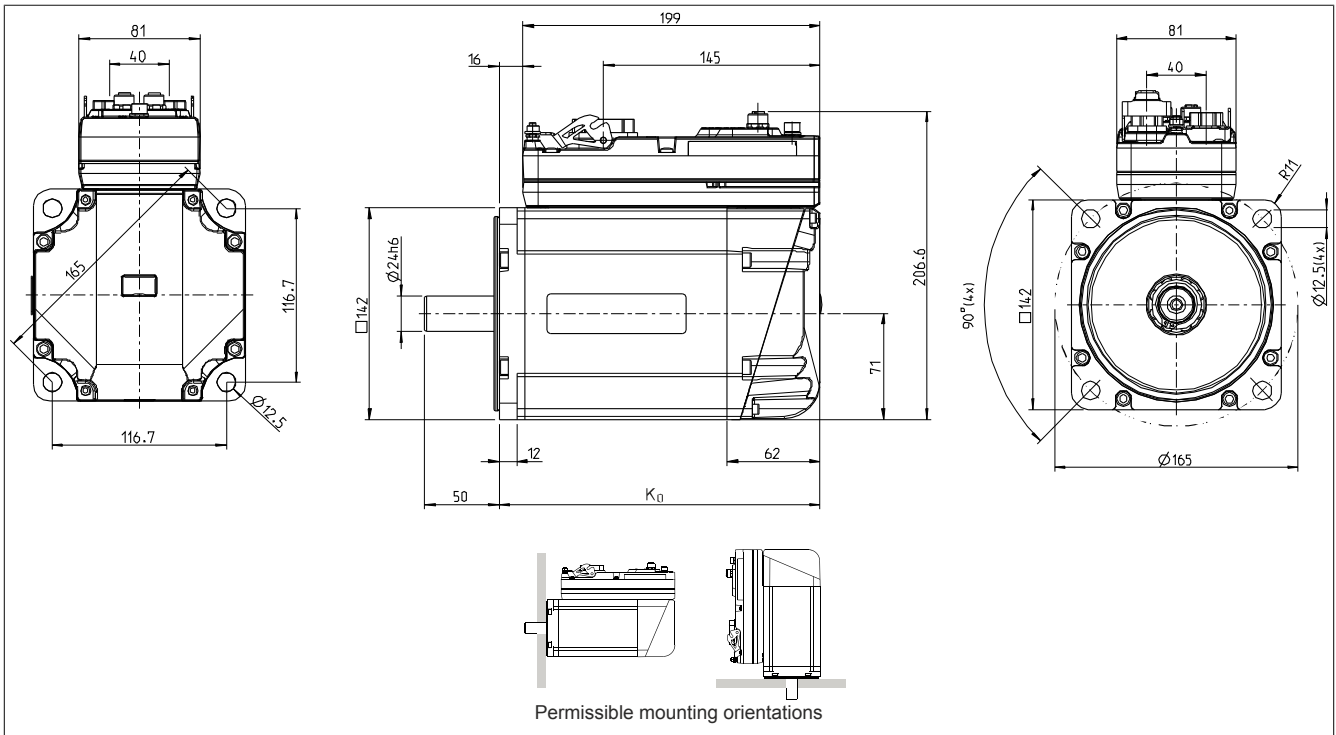

Figure 50: 8DI5de.ffggg7i00-1 - Dimension diagrams and installation dimensions

8DI5de.ffggg0i00-1

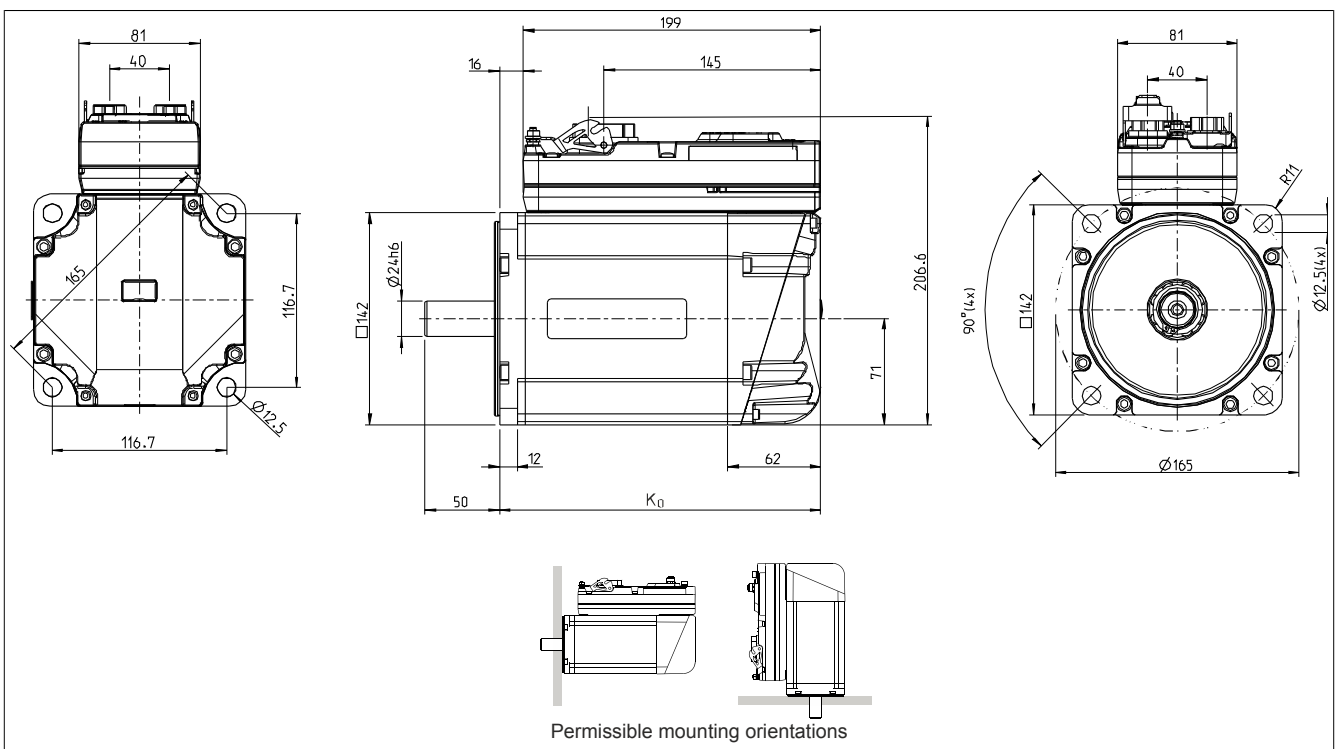

Figure 51: 8DI5de.ffggg0i00-1 - Dimension diagrams and installation dimensions

With optional fan kit 8ZDFB500000.000-0

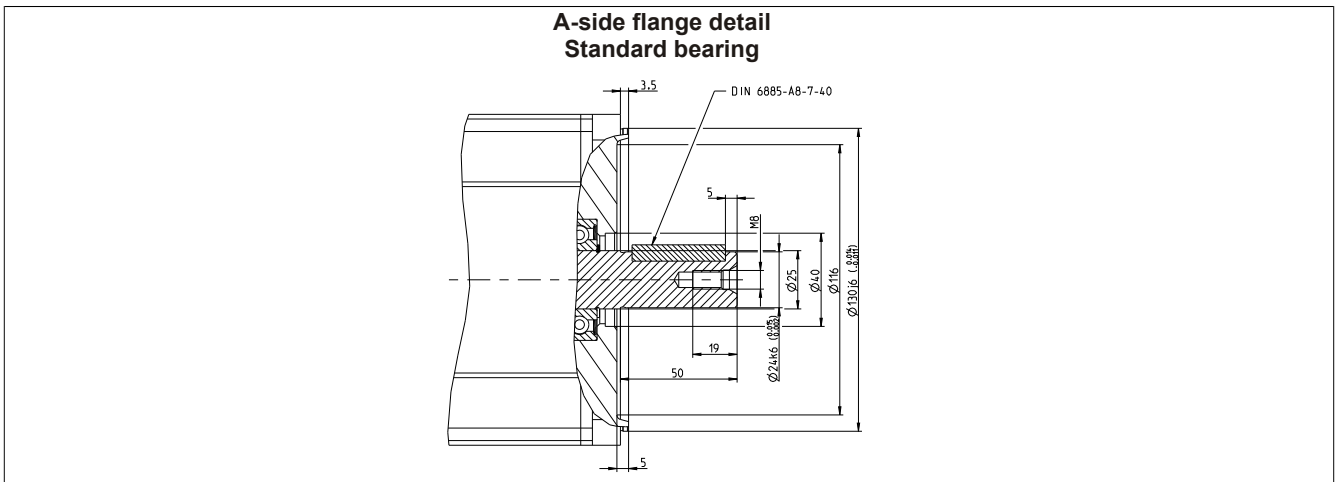
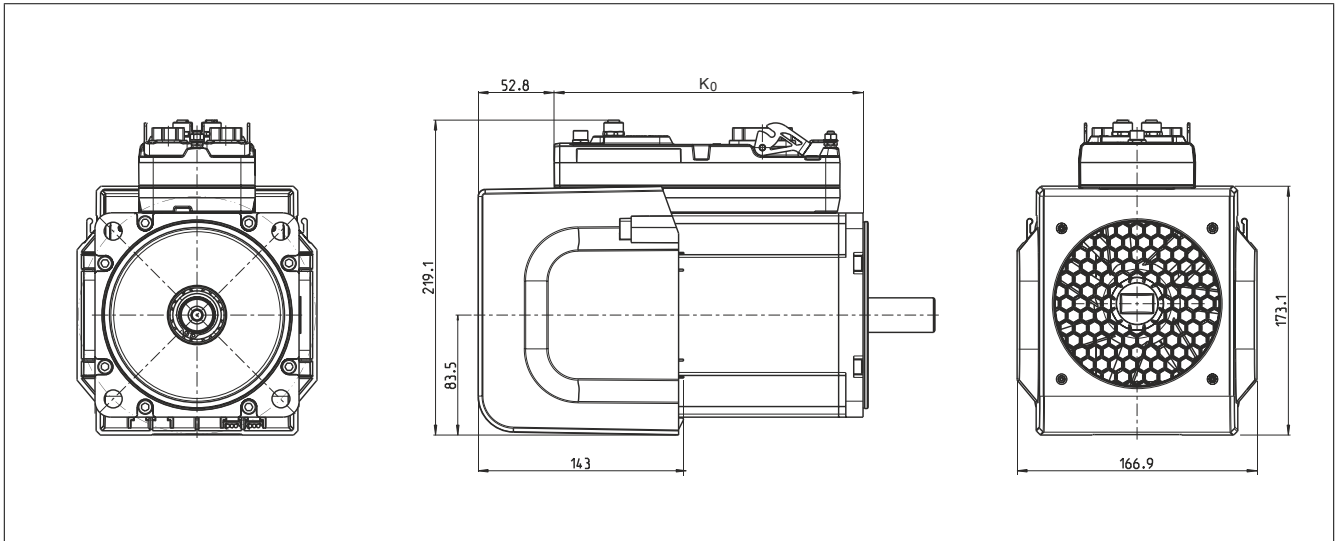
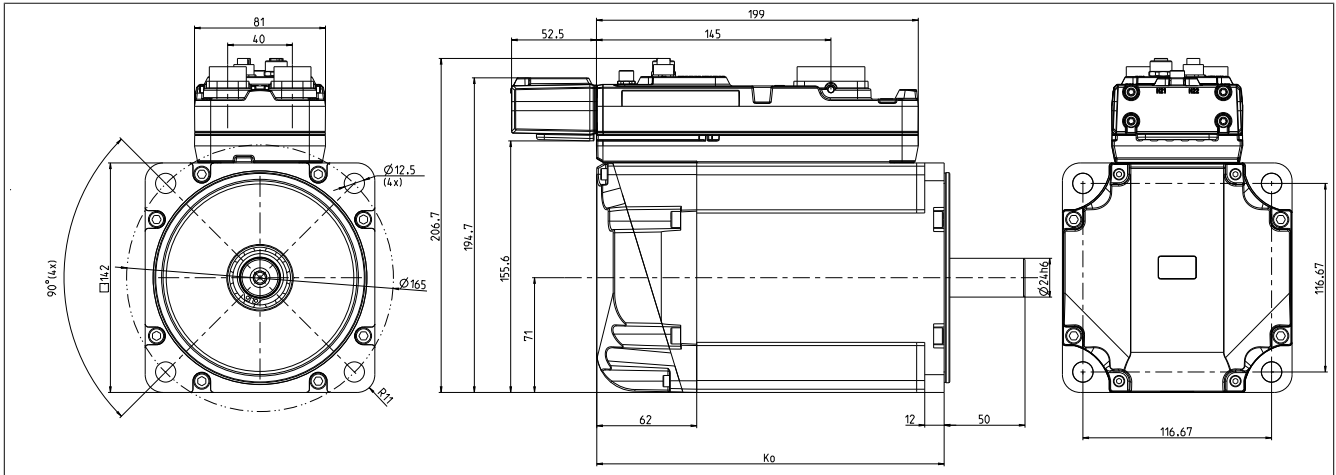

Figure 52: Flange details

Model number	K <sub>0</sub>	Extension of K <sub>0</sub> depending on motor option [mm]	
		Holding brake	Oil seal
8DI54x.Dxggghi00-1	215	35	---
8DI55x.Dxggghi00-1	240	30	---
8DI56x.Dxggghi00-1	265	30	---

4.3.13.6 SafeMOTION - Size 5

8DI5dS.ffggghi00-1



With optional fan kit 8ZDFB5000000.000-0

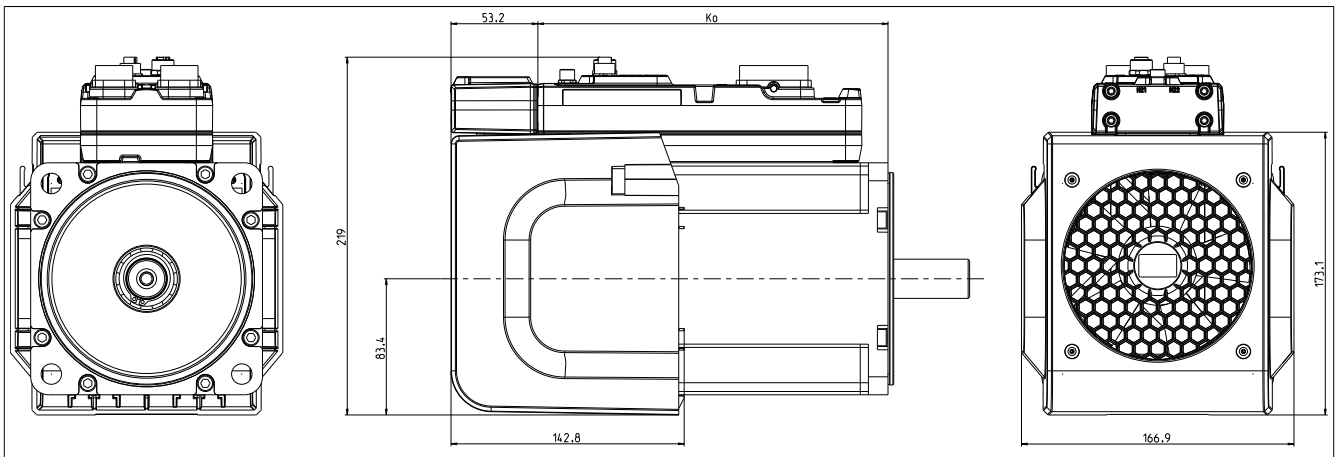

A-side flange detail  
Standard bearing

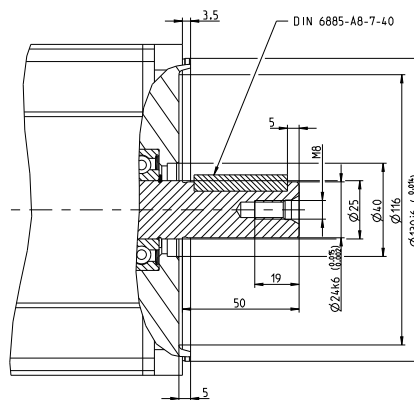

Figure 53: Flange details

Model number	K <sub>0</sub>	Extension of K <sub>0</sub> depending on motor option [mm]	
		Holding brake	Oil seal
8DI54x.Dxggghi00-1	215	35	---
8DI55x.Dxggghi00-1	240	30	---
8DI56x.Dxggghi00-1	265	30	---

4.3.13.7 Permissible mounting orientations

<p><b>IM3001 horizontal</b></p>	
<p><b>IM3031 vertical</b> (motor standing on the machine)</p>	
<p><b>IM3011 vertical</b> (motor hanging on the machine)</p>	

Table 82: Type of construction and mounting arrangement per EN 60034-7 (IM code)

### 4.3.14 Pinouts

#### Danger!

Before performing service work, disconnect the power supply and wait 5 minutes to ensure that the DC bus of the drive system has discharged. Observe regulations!

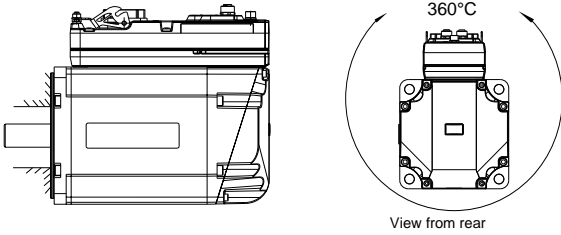
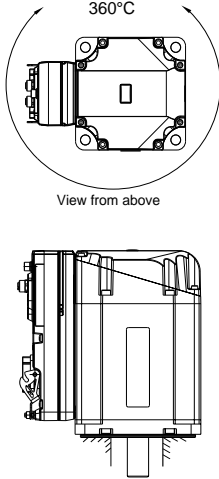
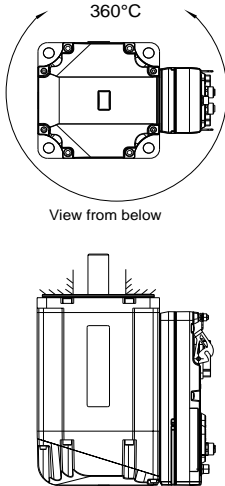
#### Warning!

Drive systems can carry high levels of electrical voltage. Never connect or disconnect the connector when voltage is present!

#### Information:

Within the scope of UL/CSA, the components of B&R drive systems are only permitted to be wired with copper cables with a permissible wire temperature of at least 75°C!

#### 4.3.14.1 Overview

#### ACOPOSmotor - Pinout

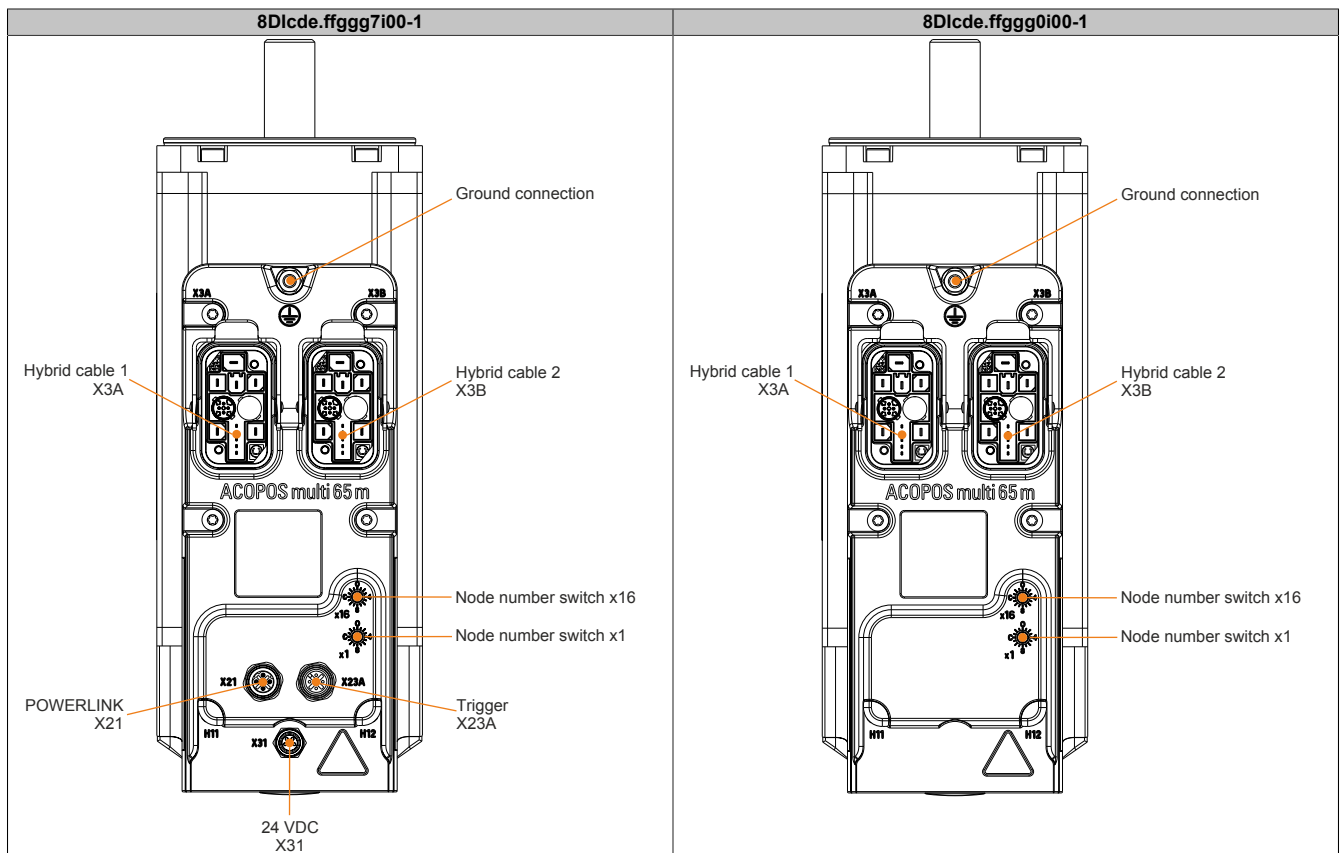
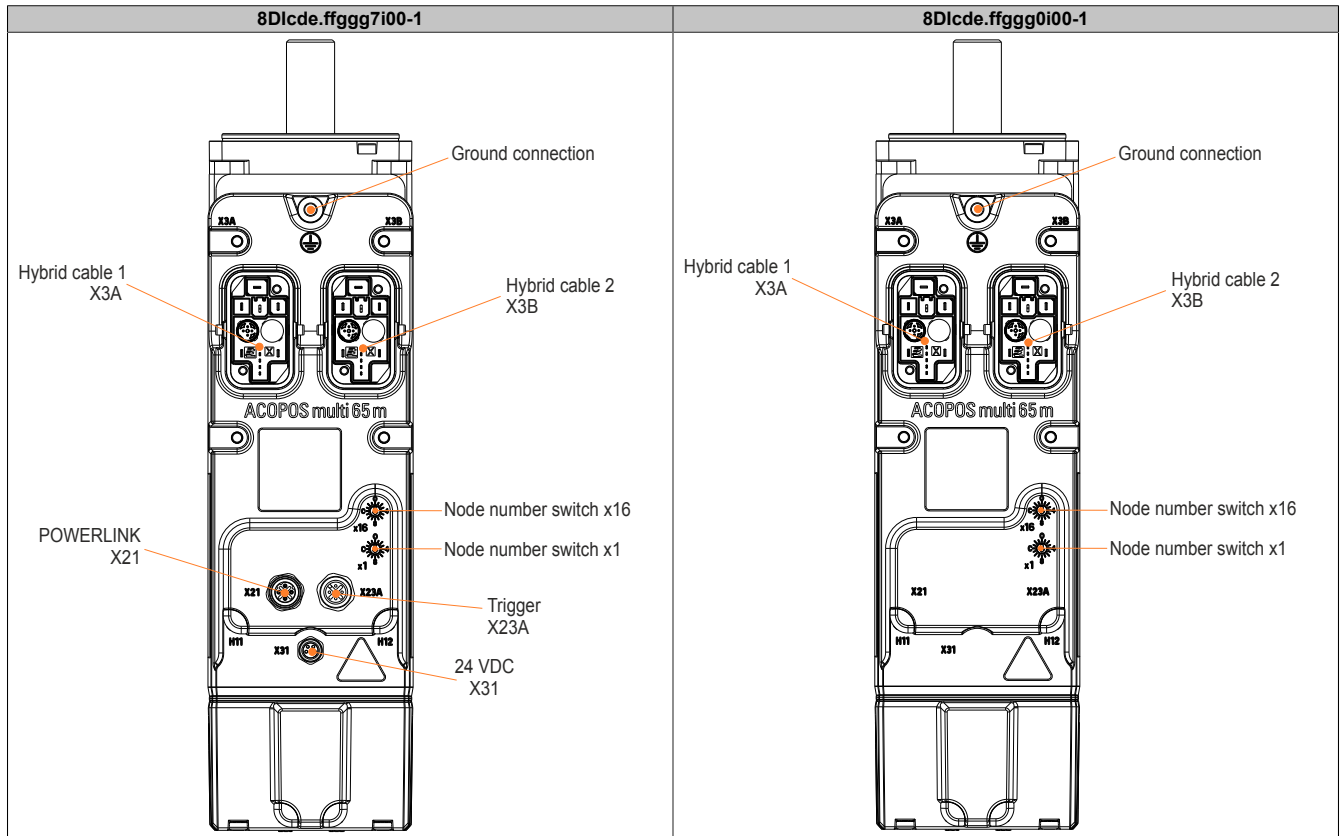

Table 83: Pinout overview

**ACOPOSmotor SafeMOTION - Pinout**



**4.3.14.1.1 X21 (POWERLINK)**

Figure	Pin	Description	Function
	1	TXD	Transmit data
	2	RXD	Receive data
	3	TXD\	Transmit data inverted
	4	RXD\	Receive data inverted

Table 84: Connector X21 - Pinout

**4.3.14.1.2 X23A (trigger)**

Figure	Pin	Description	Function
	1	+24 V	Sensor/actuator power supply 24 VDC <sup>1)</sup>
	2	Trigger1	Trigger input 1
	3	GND	GND
	4	Trigger2	Trigger input 2
	5	---	---

Table 85: Connector X23A - Pinout

1) Sensor/Actuator power supply is not permitted to be external.

### 4.3.14.1.3 X31 (24 VDC routing)

Figure	Pin	Description	Function
	1	24 VDC I/O	24 VDC I/O power supply
	2	24 VDC I/O	24 VDC I/O power supply
	3	GND	24 VDC I/O power supply 0 V
	4	GND	24 VDC I/O power supply 0 V

Table 86: Connector X31 - Pinout

### 4.3.14.1.4 Ground connection (PE)

The protective ground conductor is connected to the M5 threaded bolt provided using a cable lug.

Figure	Pin	Name	Function					
	---	PE	Protective ground conductor					
	<table border="1"> <thead> <tr> <th>Terminal cross sections</th> <th>[mm<sup>2</sup>]</th> <th>AWG</th> </tr> </thead> <tbody> <tr> <td>Cable lug for M5 threaded bolt</td> <td>0.25 - 16</td> <td>23 - 5</td> </tr> </tbody> </table>			Terminal cross sections	[mm <sup>2</sup> ]	AWG	Cable lug for M5 threaded bolt	0.25 - 16
Terminal cross sections	[mm <sup>2</sup> ]	AWG						
Cable lug for M5 threaded bolt	0.25 - 16	23 - 5						

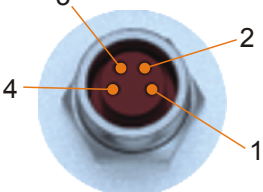
Table 87: Ground connection (PE)

### 4.3.15 Setting the POWERLINK node number

The POWERLINK node number can be set using the two HEX rotary code switches located on top of the module:

Figure	Rotary code switches	POWERLINK node number
	1	16s position (high)
	2	1s position (low)
	<p>Changed POWERLINK node numbers will not take effect until the drive system is restarted.</p> <p><b>Information:</b></p> <p>In principle, node numbers between \$01 and \$FD are permitted. However, node numbers between \$F0 and \$FD are intended for future system expansions. To ensure compatibility, these node numbers should be avoided.</p> <p>Node numbers \$00, \$FE and \$FF are reserved and may therefore not be set.</p>	

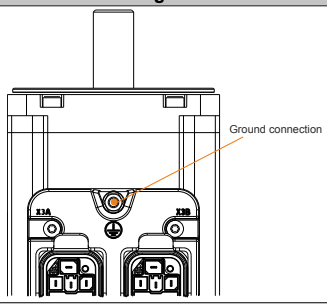
Table 88: POWERLINK node number setting

## 4.4 ACOPOSmotor Compact

### 4.4.1 8D1 order key

**8D1** **b** **c** **d** . **e** **f** **g** **h** **i** **j** **k** **ll** - **m**

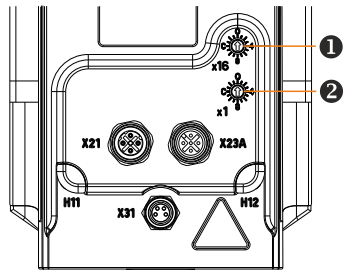
#### Construction type

- A ... Without gearbox
  - B ... Direct gearbox mounting
  - C ... Gearbox flanged
- see "Construction type (b)" on page 141

#### Size

Valid values: **2** see "Size (c)" on page 141

#### Length

Valid values: **2, 3** see "Length (d)" on page 141

#### Motor encoder system / Electronics option

Valid values: **A, B, G, H** see "Motor encoder system / Electronics option (e)" on page 142

#### Nominal speed

**D** ... 2,000 rpm      **H** ... 4,100 rpm      **I** ... 4,500 rpm  
 see "Nominal speed (f)" on page 142

#### Motor options

Valid values: **0, 1, 2, 3, 4, 5, 6, 7**  
 see "Motor options (g)" on page 142

#### Gearbox

<b>0</b> ... Without gearbox	<b>E</b> ... 8GM55 / 8GP55	<b>I</b> ... 8GF60	<b>M</b> ... 8GA50
<b>B</b> ... 8GM40 / 8GP40	<b>F</b> ... 8GP60	<b>J</b> ... 8GF70	<b>N</b> ... 8GA55
<b>C</b> ... 8GM45 / 8GP45	<b>G</b> ... 8GP70	<b>K</b> ... 8GA40	<b>P</b> ... 8GA60
<b>D</b> ... 8GM50 / 8GP50	<b>H</b> ... 8GG40 / 8GF40	<b>L</b> ... 8GA45	see "Gearbox (h)" on page 145

#### Gearbox size

<b>0</b> ... Without gearbox	<b>E</b> ... 064	<b>G</b> ... 070	<b>I</b> ... 89
<b>D</b> ... 060	<b>F</b> ... 067	<b>H</b> ... 080	<b>J</b> ... 90

see "Gearbox size (i)" on page 146

#### Gear ratio

<b>0</b> ... Without gearbox	<b>E</b> ... 007	<b>I</b> ... 012	<b>M</b> ... 025	<b>R</b> ... 50	<b>V</b> ... 80
<b>B</b> ... 003	<b>F</b> ... 008	<b>J</b> ... 015	<b>N</b> ... 032	<b>S</b> ... 60	<b>W</b> ... 100
<b>C</b> ... 004	<b>G</b> ... 009	<b>K</b> ... 016	<b>P</b> ... 035	<b>T</b> ... 64	
<b>D</b> ... 005	<b>H</b> ... 010	<b>L</b> ... 020	<b>Q</b> ... 040	<b>U</b> ... 70	

see "Gear ratio (j)" on page 147

#### Gearbox options

**0** ... Without gearbox see "Gearbox options (k)" on page 148  
 Valid values: **0, A, B, C, D, E, F, G, H, I, J, K, L, M, N, P, Q, R, S, T, U**

#### Special motor options

**00** ... No special motor options For 8GA angular planetary gearbox see "Special motor options (ll)" on page 148  
 Valid values: **00, 0A, 0B, 0C, 0D**

#### Version

**1** ... Version 1 (the motor version is specified as code (m) in the order number)

### Note:

Order keys only provide information about possible combinations in exceptional cases. Information about possible combinations is available in the CAD configurator ([cad.br-automation.com](http://cad.br-automation.com)).

4.4.1.1 Construction type (b)

**8D1 b c d . e f g h i j k ll - 1**

see "Order key" on page 140

ACOPOSmotor Compact modules are available in 3 different construction types (8D1A, 8D1B and 8D1C).

The construction type is differentiated by a letter (b) in the order number.

Construction type (b)	Cooling type	Connection type	Gearbox	Order code
8D1A	Self-cooling	Connector	Without gearbox	8D1Acd.efg000000-1
8D1B			Yes (direct mounting)	8D1Bcd.efghijkl-1
8D1C			Yes (flanged)	8D1Ccd.efghijkl-1

8D1A

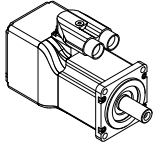

- Integrated servo drive
- Without gearbox

8D1B

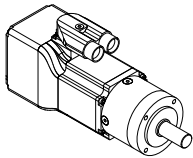

- Integrated servo drive
- Direct mounted gearbox

8D1C

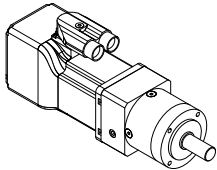

- Integrated servo drive
- Flanged gearbox

4.4.1.2 Size (c)

**8D1 b c d . e f g h i j k ll - 1**

see "Order key" on page 140

ACOPOSmotor Compact modules are available in size 2.

The size is differentiated by a digit (c) in the order number. The larger this digit, the larger the flange dimensions and power data of the respective ACOPOSmotor Compact module.

	Sizes (c)
	8D1x2
8D1A	Yes
8D1B	Yes
8D1C	Yes

4.4.1.3 Length (d)

**8D1 b c d . e f g h i j k ll - 1**

see "Order key" on page 140

ACOPOSmotor Compact modules are available in various lengths. These differ in the power data with identical flange dimensions. The different lengths are differentiated by a digit (d) in the order number.

	Lengths (d)	
	8D1xx2	8D1xx3
8D1A2	Yes	Yes
8D1B2	Yes	Yes
8D1C2	Yes	Yes

#### 4.4.1.4 Motor encoder system / Electronics option (e)

**8D1 b c d . e f g h i j k ll - 1** see "Order key" on page 140

ACOPOSmotor Compact modules are equipped with EnDat 2.2 encoders and optionally available with 2 external connections. The external connections are a combination of a 24 VDC output and trigger input.

The respective variant of the module is specified in the form of a one-digit code (e) as part of the order number.

Order code (e)	Motor encoder system	Electronics option
	Encoder type	2 external connections
A	B8	---
B	B9	---
G	B8	Yes
H	B9	Yes

#### EnDat 2.2 encoder

##### General information

Digital drive systems and position control loops require fast and highly secure transfer of data obtained from position measuring instruments. In addition, other data such as drive-specific characteristic values, correction tables, etc. should also be available. To ensure a high level of system security, measuring instruments must be integrated in routines for detecting errors and be able to perform diagnostics.

The EnDat interface from HEIDENHAIN is a digital, bidirectional interface for measuring instruments. It is able to output position values from incremental and absolute measuring instruments and can also read and update information on the measuring instrument or store new data there. Because it relies on serial data transfer, only 4 signal lines are needed. The data is transferred synchronous to the clock signal defined by the subsequent electronics. The transfer method (position values, parameters, diagnostics, etc.) is selected with mode commands that the subsequent electronics transmit to the measuring instrument.

##### Technical data

	Encoder type / Order code (ee)	
	B8	B9
Operating principle	Inductive	
EnDat protocol	EnDat 2.2	
Single-turn/Multi-turn	S	M
Revolutions	1	4096
Resolution [bits single-turn / bits multi-turn]	19/0	19/12
Accuracy ["]	120	
Cutoff frequency $\geq$ [kHz]	Digital pos. in the encoder	
Stator - Vibration during operation Max. [m/s <sup>2</sup> ]	400	
Rotor - Vibration during operation Max. [m/s <sup>2</sup> ]	600	
Max. shock during operation [m/s <sup>2</sup> ]	2000	
Probability of dangerous failure per hour (PFH) SIL 2	$\leq 15 \cdot 10^{-9}$	
Manufacturer's product ID	ECI 1119 FS EnDat22	EQI 1131 FS EnDat22

#### 4.4.1.5 Nominal speed (f)

**8D1 b c d . e f g h i j k ll - 1** see "Order key" on page 140

The nominal speed is specified as part of the order number in the form of a code (f).

	Order code (f)		
	D	H	I
Nominal speed $n_N$ [rpm]	2000	4100	4500

##### Availability

	Nominal speeds $n_N$ [rpm]		
	2000	4100	4500
8D1x22	---	---	Yes
8D1x23	Yes	Yes	---

#### 4.4.1.6 Motor options (g)

**8D1 b c d . e f g h i j k ll - 1** see "Order key" on page 140

The motor option is specified as part of the order number in the form of a one-digit code (g).

## 8D1A

Order code (g)	Motor options		
	Holding brake	Shaft end	Oil seal
0	No	Smooth shaft	No
1		Keyed shaft	
2	Yes	Smooth shaft	
3		Keyed shaft	
4	No	Smooth shaft	Yes
5		Keyed shaft	
6	Yes	Smooth shaft	
7		Keyed shaft	

## 8D1B / 8D1C

Order code (g)	Motor options		
	Holding brake	Gearbox shaft end	Oil seal
0	No	see "Gearbox options (k)" on page 148	No
2	Yes		

## Holding brake

The holding brake is a permanent magnet brake. Voltage (see the technical data) must be applied to release the brake. Based on principle, this type of holding brake exhibits a minimal amount of backlash.

The brake is designed as a holding brake. It not permitted to be used for operational braking! Loaded braking during an emergency stop is permitted but reduces its service life.

**Information:**

The required brake holding torque is determined based on the actual load torque. It is recommended by the brake manufacturer to take into account a safety factor of 2.

**Warning!**

The holding brake is not intended for normal braking. The maximum motor torque far exceeds the holding torque for the brake.

**Warning!**

The number of revolutions of the motor shaft with the holding brake applied is not permitted to exceed the value 3200 since safety function STO can no longer be ensured in this case. <sup>2)</sup>

## Technical data

	Motor size
	8D1x2
Holding torque $M_{Br}$ [Nm]	2.2
Connected load $P_{On}$ [W]	8.4
Maximum speed $n_{max}$ [rpm]	12000
Supply current $I_{On}$ [A]	0.35
Supply voltage $U_{On}$ [V]	24 VDC +6% / -10%
Moment of inertia $J_{Br}$ [kgcm <sup>2</sup> ]	0.07
Weight $m_{Br}$ [kg]	0.16
Service life	Approx. 5,000,000 switching cycles <sup>1)</sup>

1) This specification is only valid if all conditions are observed.

Releasing and re-engaging corresponds to 1 switching cycle.

The brake is designed as a holding brake. It not permitted to be used for operational braking! Loaded braking during an emergency stop is permitted but reduces its service life.

## 8D1A - Shaft end design

ACOPOSmotor Compact modules (8D1A) can be delivered with a smooth shaft end or keyed shaft end.

A **smooth shaft end** is used for a force-fit shaft-hub connection and guarantees a backlash-free connection between the shaft and hub as well as a high degree of operating smoothness. The end of the shaft has a threaded center hole.

A **keyed shaft end** is used for a form-fit torque transfer with low demands on the shaft-hub connection and for handling torque in a constant direction.

The keyways for ACOPOSmotor Compact modules conform to keyway form N1 per DIN 6885-1. Form A keyed

<sup>2)</sup> The current value of revolutions when the holding brake is applied can be read out under parameter ID BRAKE\_WEARON\_REVO.

shafts that conform to DIN 6885-1 are used. Balancing motors with keyways is done using the shaft and fitment key convention per DIN ISO 8821.

The end of the shaft has a threaded center hole that can be used to install machine actuators with shaft end cover plates.

#### **8D1A - Oil seal**

All ACOPOSmotor Compact modules without gearbox (8D1A) are available with an optional form A oil seal per DIN 3760.

With an oil seal, the ACOPOSmotor Compact modules meet the requirements for IP65 protection per EN 60529. Proper lubrication of the oil seal must be ensured throughout the entire service life of the motor.

4.4.1.7 Gearbox (h)

**8D1** **b** **c** **d** . **e** **f** **g** **h** **i** **j** **k** **ll** - **1**





see "Order key" on page 140

The gearbox is specified by a code (k) in the order key. Code 0 must be used in the order code for no gearbox.















8D1A

Order code	Gearbox type	Class	Toothing type	Degree of protection		Gearbox type - Description
0	Without gearbox	---	---	---		---

8D1B

Order code	Gearbox type	Class	Toothing type	Degree of protection		Gearbox type - Description
B	8GM40	Standard	Straight	IP54		Planetary gearbox with output shaft
C	8GM45					
D	8GM50					
E	8GM55			IP65		
H	8GG40			IP54		

8D1C

Order code	Gearbox type	Class	Toothing type	Degree of protection		Gearbox type - Description
B	8GP40	Standard	Straight	IP54		Planetary gearbox with output shaft
C	8GP45					
D	8GP50					
E	8GP55			IP65		
F	8GP60	Premium <sup>1)</sup>				
G	8GP70		Helical			
H	8GF40	Standard	Straight	IP54		Planetary gearbox with output flange
I	8GF60	Premium <sup>1)</sup>	Straight	IP65		
J	8GF70		Helical			
K	8GA40	Standard	Straight	IP54		Angular planetary gearbox
L	8GA45					
M	8GA50					
N	8GA55					
P	8GA60	Premium	Spiral bevel	IP65		

1) **Premium class**  
For applications that demand high precision. In addition to standard spur toothing, helical gearing, which runs even smoother and quieter, is also possible.

#### 4.4.1.8 Gearbox size (i)

**8D1** **b** **c** **d** . **e** **f** **g** **h** **i** **j** **k** **ll** - **1**

see "Order key" on page 140

B&R gearboxes are available in different sizes.

The gearbox size is specified by a code (i) in the order key (e.g. H).

The larger the size (e.g. 080), the larger the flange dimensions and power data of the respective gearbox.

8D1A	8D1B	8D1C
Order code ... Without gearbox	Order code ... Gearbox size	Order code ... Gearbox size
0 ... Without gearbox	D ... 060 E ... 064 F ... 067 G ... 070	D ... 060 E ... 064 F ... 067 G ... 070 H ... 080 I ... 089 J ... 090

#### 8D1B (8GM / 8GG) - Possible gearbox sizes

Gearbox series	Gearbox size <sup>1)</sup>
8GM40	060
8GM45	067
8GM50	070
8GM55	060
8GG40	064

#### 8D1C (8GP) - Possible gearbox sizes

Gearbox series	Gearbox size <sup>2)</sup>
8GP40	060, 080
8GP45	067, 089
8GP50	070, 090
8GP55	060, 080
8GP60	070
8GP70	070

#### 8D1C (8GF) - Possible gearbox sizes

Gearbox series	Gearbox size <sup>2)</sup>
8GF40	064
8GF60	064
8GF70	064

#### 8D1C (8GA) - Possible gearbox sizes

Gearbox series	Gearbox size <sup>2)</sup>
8GA40	060, 080
8GA45	067, 089
8GA50	070, 090
8GA55	064
8GA60	070

1) **1-stage or 2-stage:** Defined only by the selected gear ratio.

2) **1-stage, 2-stage or 3-stage:** Defined only by the selected gear ratio.

#### 4.4.1.9 Gear ratio (j)

**8D1 b c d . e f g h i j k ll - 1**

see "Order key" on page 140

B&R gearboxes are available with different gear ratios.

The code (j) in the order number contains the gear ratio.

8D1A	8D1B / 8D1C		
Order code ... Without gearbox	Order code ... Gear ratio		
0 ... Without gearbox	<b>B</b> ... 003	<b>I</b> ... 012	<b>Q</b> ... 040
	<b>C</b> ... 004	<b>J</b> ... 015	<b>R</b> ... 050
	<b>D</b> ... 005	<b>K</b> ... 016	<b>S</b> ... 060
	<b>E</b> ... 007	<b>L</b> ... 020	<b>T</b> ... 064
	<b>F</b> ... 008	<b>M</b> ... 025	<b>U</b> ... 070
	<b>G</b> ... 009	<b>N</b> ... 032	<b>V</b> ... 080
	<b>H</b> ... 010	<b>P</b> ... 035	<b>W</b> ... 100

#### 8D1B - Possible gear ratios

Gearbox series / Gearbox size	Gear ratio		
	1-stage:	2-stage:	3-stage:
8GM40 / 060	005, 008, 010	015, 020, 025, 032, 040, 064, 100	---
8GM45 / 067	005, 008, 010	015, 020, 025, 032, 040, 064, 100	---
8GM50 / 070	005, 008, 010	015, 020, 025, 032, 040, 064, 100	---
8GM55 / 060	005, 008, 010	015, 020, 025, 032, 040, 064, 100	---
8GG40 / 064	005, 008, 010	015, 020, 025, 032, 040, 064, 100	---

#### 8D1C (8GP) - Possible gear ratios

Gearbox series / Gearbox size	Gear ratio		
	1-stage:	2-stage:	3-stage:
8GP40 / 060	003, 004, 007	009, 012, 016	---
8GP40 / 080	003, 004, 005, 007, 008, 010	009, 012, 015, 016, 020, 025, 032, 040, 064, 100	060, 080
8GP45 / 067	003, 004, 007	009, 012, 016	---
8GP45 / 089	003, 004, 005, 007, 008, 010	009, 012, 015, 016, 020, 025, 032, 040, 064, 100	060, 080
8GP50 / 070	003, 004, 007	009, 012, 016	---
8GP50 / 090	003, 004, 005, 007, 008, 010	009, 012, 015, 016, 020, 025, 032, 040, 064, 100	---
8GP55 / 060	003, 004, 007	009, 012, 016	---
8GP55 / 080	003, 004, 005, 007, 008, 010	009, 012, 015, 016, 020, 025, 032, 040, 064, 100	---
8GP60 / 070	003, 004, 005, 007, 008, 010	012, 015, 016, 020, 025, 032, 040, 064, 100	---
8GP70 / 070	003, 004, 005, 007, 010	012, 015, 016, 020, 025, 035, 040, 050, 070, 100	---

#### 8D1C (8GF) - Possible gear ratios

Gearbox series / Gearbox size	Gear ratio		
	1-stage:	2-stage:	3-stage:
8GF40 / 064	003, 004, 007	009, 012, 016	---
8GF60 / 064	004, 005, 007, 008, 010	016, 020, 025, 032, 040, 050, 064, 100	---
8GF70 / 064	004, 005, 007, 010	016, 020, 025, 035, 040, 050, 070, 100	---

#### 8D1C (8GA) - Possible gear ratios

Gearbox series / Gearbox size	Gear ratio		
	1-stage:	2-stage:	3-stage:
8GA40 / 060	003, 004, 005, 007, 008, 010	009, 012, 015, 016, 020, 025, 032, 040, 064, 100	060, 080
8GA40 / 080	003, 004, 005, 007, 008, 010	009, 012, 015, 016, 020, 025, 032, 040, 064, 100	060, 080
8GA45 / 067	003, 004, 005, 007, 008, 010	009, 012, 015, 016, 020, 025, 032, 040, 064, 100	060, 080
8GA45 / 089	003, 004, 005, 007, 008, 010	009, 012, 015, 016, 020, 025, 032, 040, 064, 100	060, 080
8GA50 / 070	003, 004, 005, 007, 008, 010	009, 012, 015, 016, 020, 025, 032, 040, 064, 100	---
8GA50 / 090	003, 004, 005, 007, 008, 010	009, 012, 015, 016, 020, 025, 032, 040, 064, 100	---
8GA55 / 064	003, 004, 005, 007, 008, 010	009, 012, 015, 016, 020, 025, 032, 040, 064, 100	---
8GA60 / 070	004, 005, 008, 010	016, 020, 025, 032, 040, 050, 064, 100	---

### 4.4.1.10 Gearbox options (k)

**8D1 b c d . e f g h i j k ll - 1**

see "Order key" on page 140

B&R gearboxes are available with various options.

The respective option is specified by a character (**k**) in the order key.

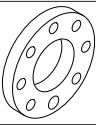
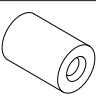
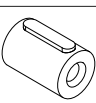
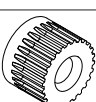
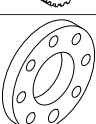
Order code		Output shaft	Variant	Backlash <sup>1)</sup>
<b>0</b>		Without gearbox (8D1A)	---	---
<b>A</b>		Flange output shaft	Standard	Standard
<b>B</b>				Reduced backlash <sup>1)</sup>
<b>C</b>				Standard
<b>D</b>			Food-grade lubrication	Reduced backlash <sup>1)</sup>
<b>E</b>		Smooth shaft	Standard	Standard
<b>F</b>				Reduced backlash <sup>1)</sup>
<b>G</b>			Food-grade lubrication	Standard
<b>H</b>				Reduced backlash <sup>1)</sup>
<b>I</b>		Keyed shaft DIN 6885 T1	Standard	Standard
<b>J</b>				Reduced backlash <sup>1)</sup>
<b>K</b>			Food-grade lubrication	Standard
<b>L</b>				Reduced backlash <sup>1)</sup>
<b>M</b>		Toothed shaft DIN 5480	Standard	Standard
<b>N</b>				Reduced backlash <sup>1)</sup>
<b>P</b>			Food-grade lubrication	Standard
<b>Q</b>				Reduced backlash <sup>1)</sup>
<b>R</b>		Flange output shaft with dowel pin hole	Standard	Standard
<b>S</b>				Reduced backlash <sup>1)</sup>
<b>T</b>				Standard
<b>U</b>			Food-grade lubrication	Reduced backlash <sup>1)</sup>

1) Reduced backlash is only available for premium gearboxes: 8GP60, 8GP70 / 8GA60, 8GA75 / 8GF60, 8GF70.

### 4.4.1.11 Special motor options (ll)

**8D1 b c d . e f g h i j k ll - 1**





see "Order key" on page 140

The special motor options are specified as part of the order number in the form of a 2-digit code (ll).

For ACOPOSmotor Compact 8D1C modules with an 8GA angular gearbox, a mounting position for the gearbox must be defined using code (ll).

For all other motors, there are no special motor options and code **00** must be used.

Valid values: **00, 0A, 0B, 0C, 0D**

	Without gearbox	With 8GP / 8GF gearbox	Order code (ll)			
			With 8GA angular gearbox (mounting position)			
			(A)	(B)	(C)	(D)
8D1A	<b>00</b>	---	---	---	---	---
8D1B	---	<b>00</b>	---	---	---	---
8D1C	---	<b>00</b>	<b>0A</b>	<b>0B</b>	<b>0C</b>	<b>0D</b>
						

#### 8D1C example:

ACOPOSmotor Compact **8D1C** with **8GA** angular gearbox in **mounting position A** (code **0A**)

Order key =**8D1Cxx.xxxxx0A-1**

#### 4.4.2 Load due to radial and axial force

Radial and axial forces ( $F_r$ ,  $F_a$ ) applied to the shaft end during operation and installation must observe the conditions listed below.

Simultaneously **loading the shaft** end with the maximum values of  $F_r$  and  $F_a$  is not permitted! Contact B&R if this occurs.

##### Radial force

Radial force  $F_r$  on the shaft end is a function of the loads during installation (e.g. belt tension on pulleys) and operation (e.g. load torque on the pinion). The maximum radial force  $F_r$  depends on the shaft end variant, bearing type, average speed, the position where the radial force is applied and the desired service life of the bearings.

##### Axial force, shift in shaft position caused by axial force

Axial force  $F_a$  on the shaft end is a function of the loads during installation (e.g. stress caused by mounting) and operation (e.g. thrust caused by slanted tooth pinions). The maximum axial force  $F_a$  depends on the bearing type and the desired service life of the bearings.

##### 8D1x2 (with holding brake)

The **fixed bearing** is secured on the **B-side flange** with a retaining ring. The floating bearing on the A-side flange is preloaded with a spring in the direction of the B-side flange. Axial forces in the direction of the A-side flange can cause the spring bias to be overcome, which shifts the shaft by the amount of axial backlash in the bearing (approx. 0.1 - 0.2 mm). This shift can cause problems on motors with holding brakes or all motors with inductive encoder systems. As a result, no axial force in excess of the calculated values is permitted in the direction of the A-side flange when using these motor (see "Determining permissible values of  $F_r$  and  $F_a$ ").

##### 8D1x2 (without holding brake)

##### 8D1x3 (with/without holding brake)

The **fixed bearing** is secured on the **A-side flange** with a retaining ring. The floating bearing on the B-side flange is preloaded with a spring in the direction of the A-side flange. Axial forces in the direction of the B-side flange can cause the spring bias to be overcome, which shifts the shaft by the amount of axial backlash in the bearing (approx. 0.1 - 0.2 mm). This shift can cause problems on motors with holding brakes or all motors with inductive encoder systems. As a result, no axial force in excess of the calculated values is permitted in the direction of the B-side flange when using these motor (see "Determining permissible values of  $F_r$  and  $F_a$ ").

##### A- and B-side flange position

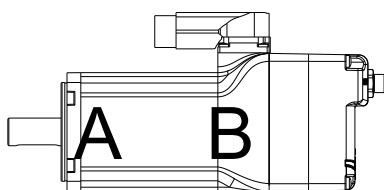

##### Definitions for maximum shaft load diagrams

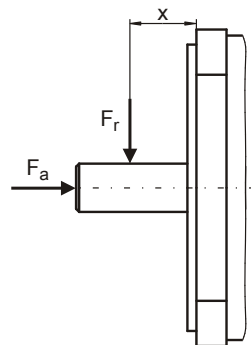

Figure 54: Definition of shaft load

- $F_r$ ..... Radial force
- $F_a$ ..... Axial force
- $x$ ..... Distance between the motor flange and the point where radial force  $F_r$  is applied

##### Overdetermined bearing

Avoid an overdetermined bearing when attaching drive elements onto the output shaft!. The necessarily occurring tolerances cause additional forces on the output shaft bearing. This can damage or significantly reduce the service life of the bearings!

### 4.4.3 Status indicators

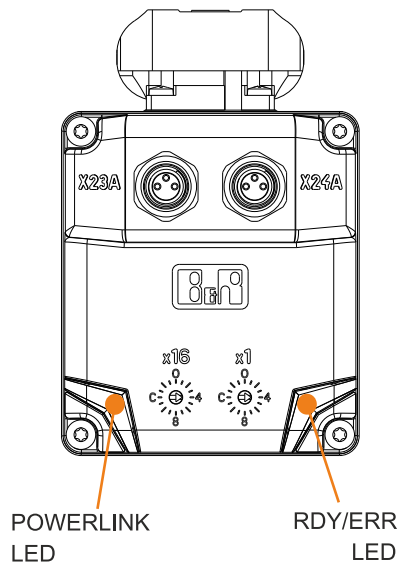

#### 4.4.3.1 POWERLINK - LED status indicators

Color	Function	Description	
Green/Red	Ready/Error	LED off	The module is not supplied with power or network interface initialization has failed.
		Solid red	The POWERLINK node number of the module is 0.
		Blinking red/green	The client is in an error state (drops out of cyclic operation).
		Blinking green (1x)	The client detects a valid POWERLINK frame on the network.
		Blinking green (2x)	Cyclic operation on the network, but the client itself is not yet in cyclic operation.
		Blinking green (3x)	Cyclic operation of the client is in preparation.
		Solid green	The client is in cyclic operation.
		Flickering green	The client is not in cyclic operation and also does not detect any other stations on the network in cyclic operation.

Table 89: POWERLINK - LED status indicators

#### 4.4.3.2 RDY/ERR - LED status indicators

Color	Function	Description	
Green	Ready	Solid green	The module is ready for operation and the power stage can be enabled (operating system present and booted, no pending permanent or temporary errors).
		Blinking green	The module is not ready for operation. <b>Examples:</b> <ul style="list-style-type: none"> <li>No signal on the enable input</li> <li>DC bus voltage outside the tolerance range</li> <li>Overtemperature on the motor</li> <li>Motor feedback not connected or defective</li> <li>Overtemperature on the module</li> <li>Disturbance on network</li> </ul>
Red	Error	Solid red	There is a permanent error on the module. <b>Examples:</b> <ul style="list-style-type: none"> <li>Permanent overcurrent</li> <li>Data in EPROM not valid</li> </ul>

Table 90: RDY/ERR - LED status indicators



#### 4.4.4 Order data for ACOPOSmotor Compact modules

Order number	Short description	Figure
	ACOPOSmotor Compact	
8D1bcd.Afghijkhh-1 8D1bcd.Bfghijkhh-1	ACOPOSmotor Compact module configuration without electronics option	
8D1bcd.Gfghijkhh-1 8D1bcd.Hfghijkhh-1	ACOPOSmotor Compact module configuration with electronics option (2x 24 VOut + trigger)	
	<b>Required accessories</b>	
	Threaded caps	
X67AC0M08	X67 M8 threaded caps, 50 pcs.	
	Accessory sets	
8F1X0A.00001000K-1	M15 blind plug caps, 30 pcs.	
	<b>Optional accessories</b>	
	Hybrid cable	
8D1CH0003.11120-0	ACOPOSmotor Compact power supply cable, length 3 m, 2x 2.5 mm <sup>2</sup> + 1x (4x 0.34 mm <sup>2</sup> ) + 1x (2x 0.34 mm <sup>2</sup> ) + 1x 0.34 mm <sup>2</sup> + PA pipe 2.0 mm / 1.0 mm, 1x 9-pin female hybrid connector, can be used in cable drag chains	
8D1CH0005.11120-0	ACOPOSmotor Compact power supply cable, length 5 m, 2x 2.5 mm <sup>2</sup> + 1x (4x 0.34 mm <sup>2</sup> ) + 1x (2x 0.34 mm <sup>2</sup> ) + 1x 0.34 mm <sup>2</sup> + PA pipe 2.0 mm / 1.0 mm, 1x 9-pin female hybrid connector, can be used in cable drag chains	
8D1CH0010.11120-0	ACOPOSmotor Compact power supply cable, length 10 m, 2x 2.5 mm <sup>2</sup> + 1x (4x 0.34 mm <sup>2</sup> ) + 1x (2x 0.34 mm <sup>2</sup> ) + 1x 0.34 mm <sup>2</sup> + PA pipe 2.0 mm / 1.0 mm, 1x 9-pin female hybrid connector, can be used in cable drag chains	
8D1CH0015.11120-0	ACOPOSmotor Compact power supply cable, length 15 m, 2x 2.5 mm <sup>2</sup> + 1x (4x 0.34 mm <sup>2</sup> ) + 1x (2x 0.34 mm <sup>2</sup> ) + 1x 0.34 mm <sup>2</sup> + PA pipe 2.0 mm / 1.0 mm, 1x 9-pin female hybrid connector, can be used in cable drag chains	
	Hybrid cable daisy chain	
8D1CH00X5.11110-0	ACOPOSmotor Compact power cable, length 0.5 m, 1x 9-pin female hybrid connector, 1x 9-pin male hybrid connector, can be used in cable drag chains	
8D1CH0001.11110-0	ACOPOSmotor Compact power cable, length 1 m, 1x 9-pin female hybrid connector, 1x 9-pin male hybrid connector, can be used in cable drag chains	
8D1CH0002.11110-0	ACOPOSmotor Compact power cable, length 2 m, 1x 9-pin female hybrid connector, 1x 9-pin male hybrid connector, can be used in cable drag chains	
8D1CH0003.11110-0	ACOPOSmotor Compact power cable, length 3 m, 1x 9-pin female hybrid connector, 1x 9-pin male hybrid connector, can be used in cable drag chains	
8D1CH0005.11110-0	ACOPOSmotor Compact power cable, length 5 m, 1x 9-pin female hybrid connector, 1x 9-pin male hybrid connector, can be used in cable drag chains	
8D1CH0010.11110-0	ACOPOSmotor Compact power cable, length 10 m, 1x 9-pin female hybrid connector, 1x 9-pin male hybrid connector, can be used in cable drag chains	
8D1CH0015.11110-0	ACOPOSmotor Compact power cable, length 15 m, 1x 9-pin female hybrid connector, 1x 9-pin male hybrid connector, can be used in cable drag chains	
	M8 sensor cable (for modules with 24 VOut + trigger connection)	
X67CA0D40.0020	M8 sensor cable, M8, 3-pin, straight, 1 m	
X67CA0D40.0050	M8 sensor cable, M8, 3-pin, straight, 5 m	
X67CA0D40.0100	M8 sensor cable, M8, 3-pin, straight, 10 m	
X67CA0D40.0150	M8 sensor cable, M8, 3-pin, straight, 15 m	
X67CA0D40.0200	M8 sensor cable, M8, 3-pin, straight, 20 m	
X67CA0D50.0020	M8 sensor cable, M8, 3-pin, angled, 1 m	
X67CA0D50.0050	M8 sensor cable, M8, 3-pin, angled, 5 m	
X67CA0D50.0100	M8 sensor cable, M8, 3-pin, angled, 10 m	
X67CA0D50.0150	M8 sensor cable, M8, 3-pin, angled, 15 m	
X67CA0D50.0200	M8 sensor cable, M8, 3-pin, angled, 20 m	

Table 92: 8D1bcd.efghijkhh-1 - Order data

## 4.4.5 Technical data

### 4.4.5.1 General information

General information	
Module type	ACOPOSmotor Compact
Current-carrying capacity of 9-pin hybrid connector	
Power contacts	Max. 20 A at 40°C
Certifications	
CE	Yes
UL	cURus E225616 Power conversion equipment
Support	
Motion system	
mapp Motion	V5.17 or higher
ACP10	V5.17 or higher
Thermal properties	
Cooling method per EN 60034-6 (IC code)	
Standard	Self-cooling, free circulation surface cooling (IC4A0A0)
Operating conditions	
Type of construction and mounting arrangement per EN 60034-7 (IM code)	Horizontal, motor shaft aligned horizontally (IM 3001) Vertical, motor standing on the machine (IM 3011) Vertical, motor hanging on the machine (IM 3031) <sup>1)</sup>
Reduction of the continuous current at temperatures above 40°C: 8D1A22.eI... (4500 rpm) 8D1A23.eD... (2000 rpm) 8D1A23.eH... (4100 rpm)	0.156 A/K 0.139 A/K 0.273 A/K
Reduction of the nominal current and stall current at installation elevations over 1000 m above sea level	-10% per 1,000 m
Installation elevation above sea level	
Nominal	0 to 500 m
Maximum	4,000 m
Degree of protection per EN 60529 <sup>2)</sup>	Without oil seal option: IP54 With oil seal option: IP65
Degree of protection per UL 50	Type 1
Ambient conditions	
Temperature	
Operation	
Nominal	5 to 40°C
Maximum	55°C <sup>3)</sup>
Storage	-25 to 55°C
Transport	-25 to 70°C
Max. flange temperature	65°C
Relative humidity	
Operation	5 - 85%, non-condensing
Storage	5% - 95%, non-condensing
Transport	Max. 95% at 40°C
Mechanical properties	
Motor coating	Water-based paint, RAL 9005 flat
Inverter coating	EPD coating, RAL 9005 flat
Roller bearing, dynamic load rating and nominal service life	Based on DIN ISO 281
Shaft end per DIN 748	Form E
Oil seal per DIN 3760	Form A
Key and keyway per DIN 6885-1	Keyway form N1, key form A
Shaft balancing per ISO 1940/1, G6.3	Shaft and fitment key convention
Radial runout, concentricity and axial runout of mounting flange per DIN 42955	Tolerance R

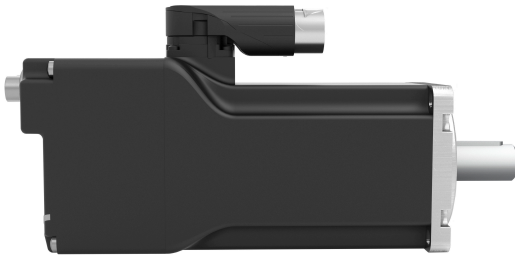
Table 93: Technical data

- 1) The IM3031 type of construction and mounting arrangement (vertical, motor hanging on the machine) must be avoided since production fluids or oils, e.g. from a gearbox, can penetrate the motor and damage it. If this is not possible, it is mandatory to select the oil seal option and to ensure that no production fluids or oils get onto the seal.
- 2) The specified degree of protection is only met if all connectors on the module that are not being used are closed with suitable threaded caps or slot covers! Suitable threaded caps covers are available as optional accessories. The module is delivered with IP20 protection.
- 3) Continuous operation at an ambient temperature of 40°C to max. 55°C is possible taking the reduction of continuous torque into account, but this results in premature aging of components.

### 4.4.5.2 Inverter module

Product ID	8D1xxx.A... 8D1xxx.B...	8D1xxx.G... 8D1xxx.H...
<b>DC bus connection</b>		
Voltage		
Minimum		24 VDC
Nominal		54 VDC
Maximum		58 VDC
Continuous power consumption <sup>1)</sup>	$P_{\text{mech}} / 0.85 + P_{\text{In}} (\text{optional}) + P_{24\text{VDC,Out}} (\text{optional}) + 10 \text{ W}$	
DC bus capacitance	264 $\mu\text{F}$	
Variant	9-pin hybrid connector <sup>3)</sup>	
Max. line length	15 m <sup>2)</sup>	
<b>24 VDC Out 1</b>		
Output voltage <sup>7)</sup>	-	24 VDC $\pm 3\%$
Continuous current	-	Max. 250 mA <sup>4)</sup>
Fuse protection	-	Electronic
Variant	M8 connector	
Max. line length	30 m	
<b>24 VDC Out 2</b>		
Output voltage <sup>7)</sup>	-	24 VDC $\pm 3\%$
Continuous current	-	Max. 250 mA <sup>4)</sup>
Fuse protection	-	Electronic
Variant	M8 connector	
Max. line length	30 m	
<b>Motor connection</b>		
Nominal switching frequency	40 kHz	
Max. output frequency	598 Hz <sup>5)</sup>	
<b>Motor holding brake</b>		
Max. switching frequency	0.5 Hz	
Response threshold for undervoltage monitoring	24 VDC -10%	
<b>Fieldbus</b>		
Type	POWERLINK V2 controlled node (CN)	
Variant	Internal 2-port hub, 2x 9-pin male hybrid connector <sup>3)</sup>	
Cable length	Max. 30 m between two stations	
Transfer rate	100 Mbit/s	
<b>Enable inputs</b>		
Quantity	1	
Circuit	Sink	
Electrical isolation		
Input - Inverter module	Yes	
Input voltage		
Nominal	24 VDC	
Maximum	30 VDC	
Input current at nominal voltage	Approx. 4 mA (typical/nominal)	
Switching threshold		
Low	<5 V	
High	>15 V	
Switching delay at nominal input voltage		
Enable 1 $\rightarrow$ 0, PWM off	2 ms	
Enable 0 $\rightarrow$ 1, ready for PWM	1 ms	
Modulation compared to ground potential	Max. $\pm 38 \text{ V}$	
OSSD signal connections	0.05-0.5 ms <sup>6)</sup>	
Variant	9-pin hybrid connector <sup>3)</sup>	
<b>Trigger inputs</b>		
Quantity	-	2
Circuit	-	Sink
Electrical isolation		
Input - Inverter module	-	No
Input - Input	-	No
Input voltage		
Nominal	-	24 VDC
Maximum	-	30 VDC
Switching threshold		
Low	-	<5 V
High	-	>15 V
Input current at nominal voltage	-	4 mA
Switching delay		
Rising edge	-	51 $\mu\text{s}$
Falling edge	-	51 $\mu\text{s}$
Modulation compared to ground potential	-	Max. $\pm 38 \text{ V}$
Variant	-	M8 female connector, 3-pin

Table 94: 8D1bcd.efghijkhh-1 - Technical data

Product ID	8D1xxx.A... 8D1xxx.B...	8D1xxx.G... 8D1xxx.H...
Max. line length	30 m	
<b>Support</b>		
Motion system		
mapp Motion	V5.17 or higher	
ACP10	V5.17 or higher	

Table 94: 8D1bcd.efghijkhh-1 - Technical data

- 1) Valid under the following conditions: 54 VDC DC bus voltage, 40 kHz switching frequency, 40°C ambient temperature, installation elevation <500 m above sea level, no derating due to cooling type.  
 $P_{mech}$  ... Mechanical power at the motor shaft:  $P_{mech} = \omega \cdot M = 2\pi \cdot n \text{ [rpm]} / 60 \text{ s} \cdot M$   
 $P_{in}$  ... Connection power of the holding brake depending on the motor size, see "holding brake technical data" on page 142  
 $P_{24VDC,Out}$  ... Maximum power consumption of the 24 VDC output: 7 W
- 2) Also valid for the daisy-chain connection from module to module.
- 3) <500 mating cycles
- 4) The continuous current of 24 VDC Out 1 and Out 2 together are not permitted to exceed 250 mA.
- 5) The module's electrical output frequency (SCTRL\_SPEED\_ACT \* MOTOR\_POLEPAIRS) is monitored to protect against dual use in accordance with Regulation (EC) 428/2009 | 3A225. If the electrical output frequency of the module exceeds the limit value of 598 Hz uninterrupted for more than 0.5 s, then the current movement is aborted and error 6060 is output ("Power unit: Limit speed exceeded").
- 6) If shorter or no OSSD low pulses are applied, STO must be tested manually at regular intervals. If this is not done, the safety characteristics cannot be maintained. (Diagnostic test interval: see "Chapter "Safety technology", ACOPOSmotor Compact, General information, Table 1" on page 335)
- 7) Depends on the DC bus. Dropout voltage of 2 V must be taken into account. starting at a DC bus voltage <26 VDC.

### 4.4.5.3 Power dissipation

Power from ACOPOSmotor Compact modules is dissipated via the motor flange and surface of the motor. The following factors are important to ensure optimal heat dissipation:

- Thermally open installation
- Free convection

The motor data specified for the nominal operating point apply to a motor installed in a thermally open system. The dimensions of the flange plates used for the measurement are shown in the table below.

Generally speaking, the larger the flange, the better the heat dissipation.

Size	Dimensions [mm]	Material
8D1x2	250 x 250 x 6	Aluminum

## 4.4.5.4 Formula symbols

Term	Symbol	Unit	Description
Nominal speed	$n_N$	rpm	Nominal speed of the motor
Nominal torque	$M_N$	Nm	The nominal torque is output by the motor ( $n = n_N$ ) when the nominal current is being drawn. This is possible for any length of time if the ambient conditions are correct.
Nominal power	$P_N$	kW	The nominal power is supplied by the motor when $n = n_N$ . This is possible for any length of time if the ambient conditions are correct.
Nominal current	$I_N$	A	The nominal current is the RMS value for the phase current (current in the motor supply line) when generating the nominal torque at the nominal speed. This is possible for any length of time if the ambient conditions are correct.
Stall torque	$M_0$	Nm	The stall torque is output by the motor at the speed $n_0$ and when the stall current is being applied. This is possible for any length of time if the ambient conditions are correct. Speed $n_0$ must be high enough for the temperature in all windings to be homogeneous and stationary (for B&R motors, $n_0 = 50$ rpm). The continuous torque is reduced when the motor is at a complete standstill.
Stall current	$I_0$	A	The stall current is the RMS value of the phase current (current in the motor supply line) for generating the stall torque at speed $n_0$ . This is possible for any length of time if the ambient conditions are correct. Speed $n_0$ must be high enough for the temperature in all windings to be homogeneous and stationary (for B&R motors, $n_0 = 50$ rpm).
Peak torque	$M_{max}$	Nm	The peak torque is briefly output by the motor when the peak current is being drawn.
Peak current	$I_{max}$	A	The peak current is the RMS value of the phase current (current in the motor supply line) for generating the peak torque. This is only permitted for a short time. The peak current is determined by the magnetic circuit. Exceeding this value for a short time can cause irreversible damage (demagnetization of the magnet material).
Maximum speed	$n_{max}$	rpm	Maximum motor speed. This is a mechanical condition (centrifugal force, bearing wear).
Average speed	$n_{average}$	rpm	Average speed for one cycle
Torque constant	$K_T$	Nm/A	The torque constant specifies the torque generated by the motor at 1 Arms phase current. This value applies at a motor temperature of 20°C. If the temperature increases, the torque constant is reduced (typically down to 10%). If the current increases, the torque constant is reduced (typically starting at twice the value of the nominal current).
Voltage constant	$K_E$	V/1000 rpm	The voltage constant specifies the RMS value (phase-phase) of the reverse voltage induced by the motor at a speed of 1000 rpm (EMF). This value applies at a motor temperature of 20°C. When the temperature increases, the voltage constant is reduced (usually down to 5%). If the current increases, the voltage constant is reduced (typically starting at twice the value of the nominal current).
Stator resistance	$R_{2ph}$	$\Omega$ (Ohm)	Resistance measured in ohms between two motor leads (phase-phase) at 20°C winding temperature. On B&R motors, the windings use a star connection.
Stator inductance	$L_{2ph}$	mH	Winding inductance measured between two motor leads. Stator inductance depends on the rotor position.
Electrical time constant	$t_{el}$	ms	Corresponds to 1/5 of the time needed for the stator current to stabilize with constant operating conditions.
Thermal time constant	$t_{therm}$	Min	Corresponds to 1/5 of the time needed for the motor temperature to stabilize with constant operating conditions.
Moment of inertia without brake	$J$	kgcm <sup>2</sup>	Moment of inertia for a motor without a holding brake
Weight without brake	$m$	kg	Mass of motor without holding brake
Moment of inertia of brake	$J_{Br}$	kgcm <sup>2</sup>	Moment of inertia for the built-in holding brake
Mass of brake	$m_{Br}$	kg	Mass of built-in holding brake
Brake holding torque	$M_{Br}$	Nm	Minimum torque required to hold the rotor when the brake is activated
Installed load	$P_{on}$	W	Installed load for the built-in holding brake
Installed current	$I_{on}$	A	Installed current for the built-in holding brake
Connection voltage	$U_{on}$	V	Operating voltage for the built-in holding brake
Activation delay	$t_{on}$	ms	Delay time required for the holding torque of the brake to be established after the operating voltage has been removed from the holding brake
Release delay	$t_{off}$	ms	Delay time required until the holding torque of the holding brake is reduced by 90% (the brake is released) after operating voltage has been returned to the holding brake

## 4.4.6 8D1A2 - Technical data

### 4.4.6.1 Technical data

Order number	8D1A22.elg000000-1	8D1A23.eDg000000-1	8D1A23.eHg000000-1
<b>General information</b>			
Certifications			
CE	Yes		
UL	cURus E225616 Power conversion equipment		
<b>Motor</b>			
Nominal speed $n_N$ [rpm]	4500	2000	4100
Number of pole pairs	5		
Nominal torque $M_N$ [Nm]	0.536	1.047	0.792
Nominal power $P_N$ [W]	253	219	340
Nominal current $I_N$ [A]	5.36	4.76	7.2
Stall torque $M_0$ [Nm]	0.659	1.118	0.88
Stall current $I_0$ [A]	6.59	5.08	8
Maximum torque $M_{max}$ [Nm]	1.34	3.01	1.56
Maximum current $I_{max}$ [A]	15.7		
Maximum speed $n_{max}$ [rpm]	6600		
Torque constant $K_T$ [Nm/A]	0.1	0.22	0.11
Voltage constant $K_E$ [V/1000 rpm]	5.97	13.41	6.6
Stator resistance $R_{zph}$ [ $\Omega$ ]	0.4	0.76	0.2
Stator inductance $L_{zph}$ [mH]	0.37	0.93	0.24
Electrical time constant $t_{el}$ [ms]	0.93	1.2	
Thermal time constant $t_{therm}$ [min]	35	38	
Moment of inertia $J$ [kgcm <sup>2</sup> ]	0.22	0.41	
Weight without brake $m$ [kg]	1.26	1.62	
<b>Holding brake</b>			
Holding torque of brake $M_{Br}$ [Nm]	2.2		
Mass of brake [kg]	0.28		
Moment of inertia of brake $J_{Br}$ [kgcm <sup>2</sup> ]	0.12		

Table 95: 8D1A22.elg000000-1, 8D1A23.eDg000000-1, 8D1A23.eHg000000-1 - Technical data

### 4.4.6.2 8D1A22.elghjkh-1 - Speed-Torque characteristic curve

With 54 VDC DC bus voltage

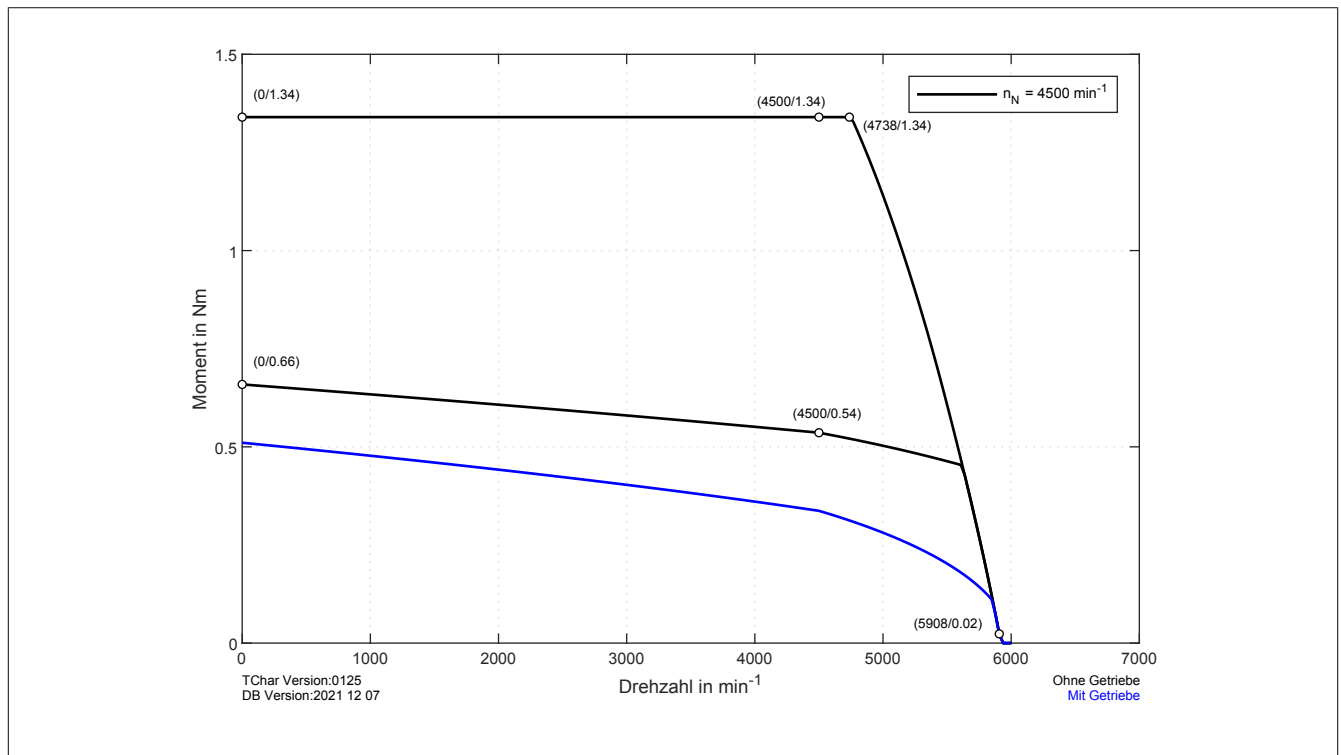

Figure 55: 8D1A22.elghjkh-1 with 54 VDC DC bus voltage - Speed-torque characteristic curve

### 4.4.6.3 8D1A23.eDghijkh-1 - Speed-Torque characteristic curve

With 54 VDC DC bus voltage

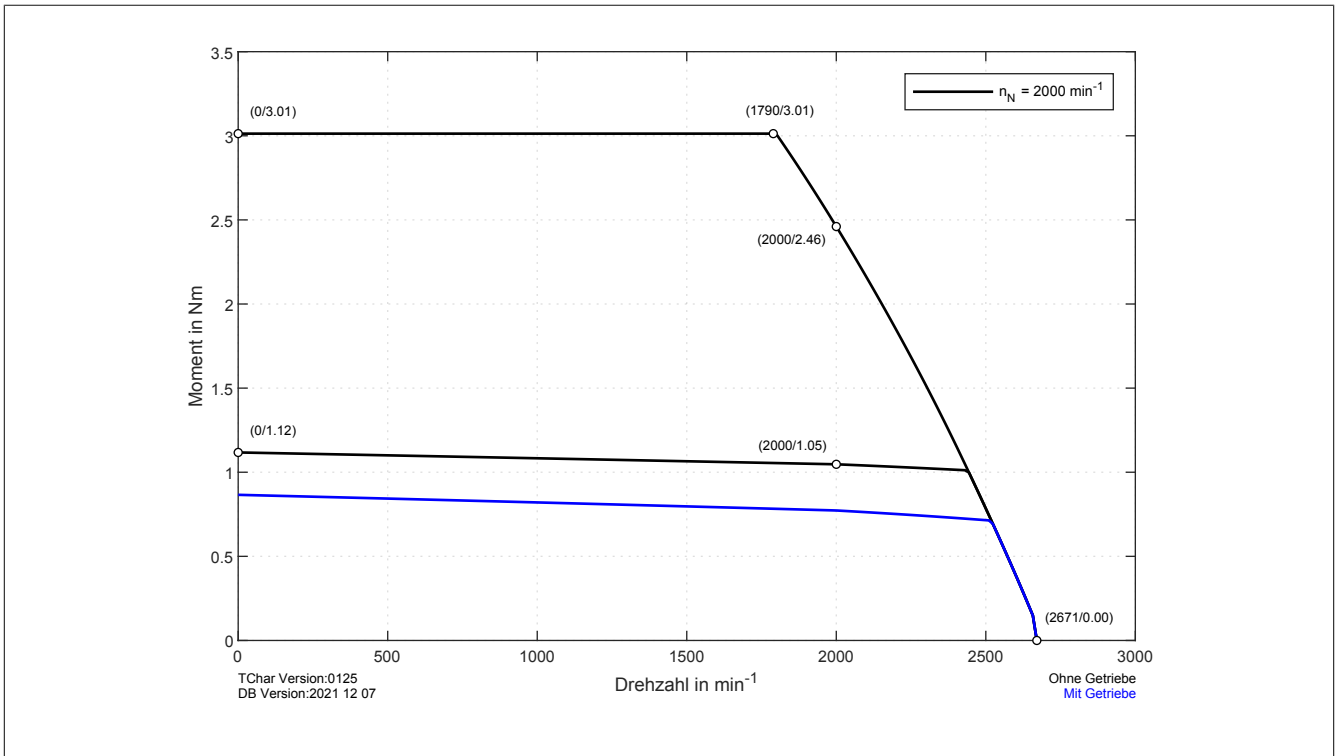

Figure 56: 8D1A23.eDghijkh-1 with 54 VDC DC bus voltage - Speed-torque characteristic curve

### 4.4.6.4 8D1A23.eHghijkh-1 - Speed-Torque characteristic curve

With 54 VDC DC bus voltage

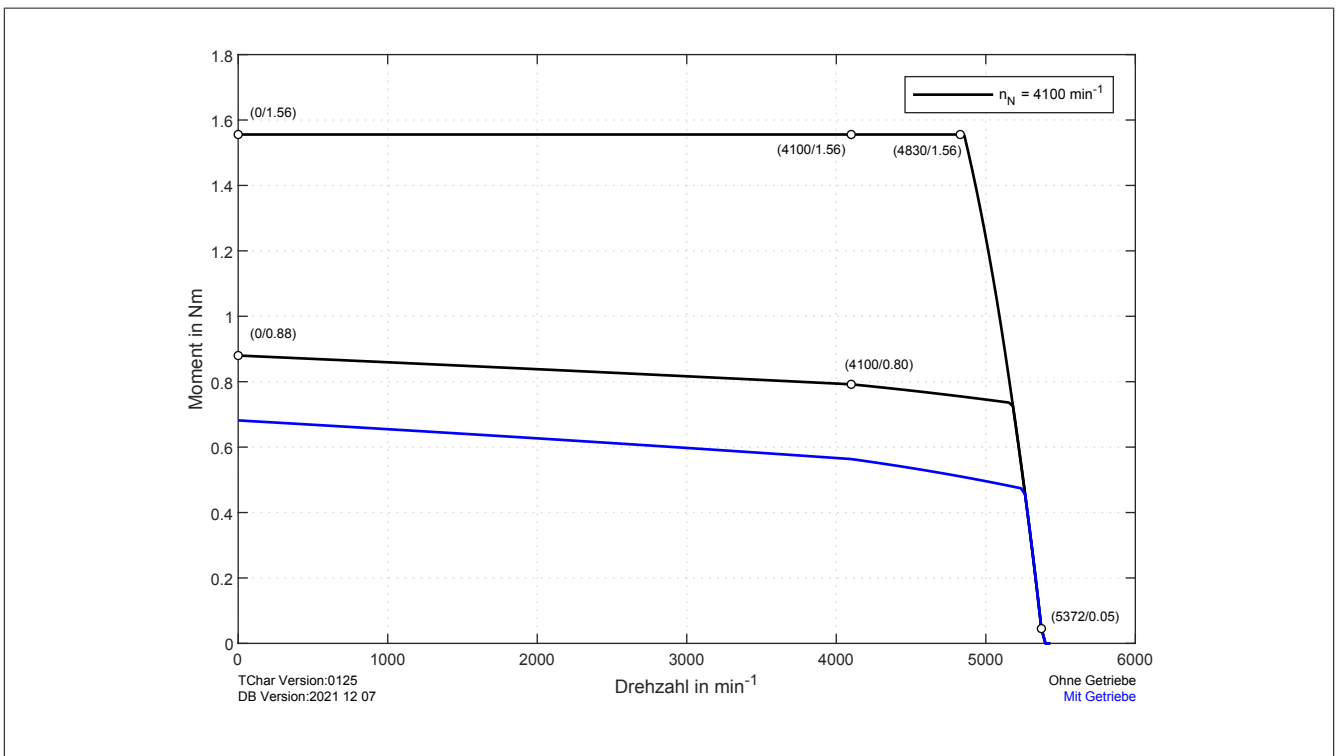
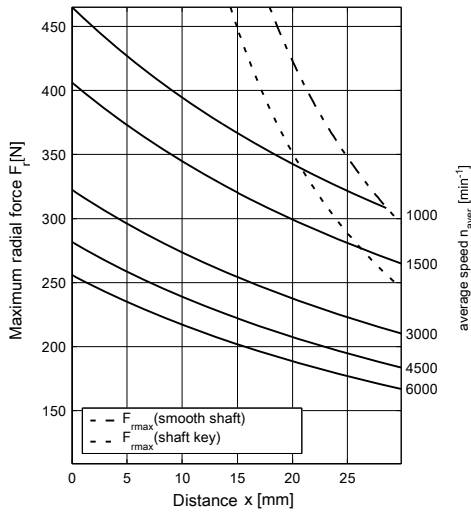

Figure 57: 8D1A23.eHghijkh-1 with 54 VDC DC bus voltage - Speed-torque characteristic curve

### 4.4.6.5 Maximum shaft load

The values in the diagram below are based on a mechanical service life of the bearings of 20000 operating hours.



maximum allowed axial force:  $F_{amax} = 42 \text{ N}$

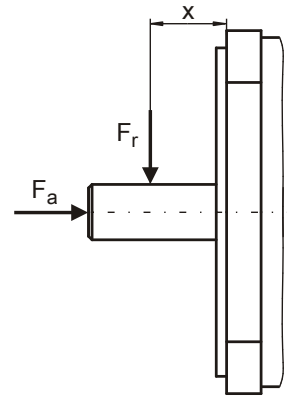

Figure 58: Definition of shaft load

$F_r$ ..... Radial force





$F_a$ ..... Axial force

$x$ ..... Distance between the motor flange and the point where radial force  $F_r$  is applied.





## 4.4.7 8D1B2 - Technical data

### 4.4.7.1 Overview





#### 8D1B22 - 4,500 rpm

Order number	Gearbox type Gearbox size		Technical data
8D1B22.elgBD	8GM40, 060		see "8D1B22.el - 4,500 rpm (8GM40, gearbox size 060) - Technical data" on page 161
8D1B22.elgCF	8GM45, 067		see "8D1B22.el - 4,500 rpm (8GM45, gearbox size 067) - Technical data" on page 163
8D1B22.elgDG	8GM50, 070		see "8D1B22.el - 4,500 rpm (8GM50, gearbox size 070) - Technical data" on page 165
8D1B22.elgED	8GM55, 060		see "8D1B22.el - 4,500 rpm (8GM55, gearbox size 060) - Technical data" on page 167
8D1B22.elgHE	8GG40, 064		see "8D1B22.el - 4,500 rpm (8GG40, gearbox size 064) - Technical data" on page 169

#### 8D1B23 - 2,000 rpm

Order number	Gearbox type Gearbox size		Technical data
8D1B23.eDgBD	8GM40, 060		see "8D1B23.eD - 2,000 rpm (8GM40, gearbox size 060) - Technical data" on page 171
8D1B23.eDgCF	8GM45, 067		see "8D1B23.eD - 2,000 rpm (8GM45, gearbox size 067) - Technical data" on page 173
8D1B23.eDgDG	8GM50, 070		see "8D1B23.eD - 2,000 rpm (8GM50, gearbox size 070) - Technical data" on page 175
8D1B23.eDgED	8GM55, 060		see "8D1B23.eD - 2,000 rpm (8GM55, gearbox size 060) - Technical data" on page 175
8D1B23.eDgHE	8GG40, 064		see "8D1B23.eD - 2,000 rpm (8GG40, gearbox size 064) - Technical data" on page 179

#### 8D1B23 - 4,100 rpm

Order number	Gearbox type Gearbox size		Technical data
8D1B23.eHgBD	8GM40, 060		see "8D1B23.eH - 4,100 rpm (8GM40, gearbox size 060) - Technical data" on page 181
8D1B23.eHgCF	8GM45, 067		see "8D1B23.eH - 4,100 rpm (8GM45, gearbox size 067) - Technical data" on page 183
8D1B23.eHgDG	8GM50, 070		see "8D1B23.eH - 4,100 rpm (8GM50, gearbox size 070) - Technical data" on page 185
8D1B23.eHgED	8GM55, 060		see "8D1B23.eH - 4,100 rpm (8GM55, gearbox size 070) - Technical data" on page 185
8D1B23.eHgHE	8GG40, 064		see "8D1B23.eH - 4,100 rpm (8GG40, gearbox size 064) - Technical data" on page 189

## 4.4.7.2 8D1B22.el - 4,500 rpm (8GM40, gearbox size 060) - Technical data

## Gear ratio 005 to 020

Order number	8D1B22. elgBDDk00-1	8D1B22.elgBDFk00-1	8D1B22. elgBDHk00-1	8D1B22.elgBDJk00-1	8D1B22.elgBDLk00-1
<b>General information</b>					
Certifications					
CE	Yes				
<b>Motor</b>					
Nominal speed $n_N$ [rpm]	4500				
Number of pole pairs	5				
Nominal torque $M_N$ [Nm]	0.536				
Nominal power $P_N$ [W]	253				
Nominal current $I_N$ [A]	5.36				
Stall torque $M_0$ [Nm]	0.659				
Stall current $I_0$ [A]	6.59				
Maximum torque $M_{max}$ [Nm]	1.34				
Maximum current $I_{max}$ [A]	15.7				
Maximum speed $n_{max}$ [rpm]	6600				
Torque constant $K_T$ [Nm/A]	0.1				
Voltage constant $K_E$ [V/1000 rpm]	5.97				
Stator resistance $R_{zph}$ [ $\Omega$ ]	0.4				
Stator inductance $L_{zph}$ [mH]	0.37				
Electrical time constant $t_{el}$ [ms]	0.93				
Thermal time constant $t_{therm}$ [min]	35				
Moment of inertia $J$ [kgcm <sup>2</sup> ]	0.22				
Weight without brake $m$ [kg]	1.26				
Max. permissible output torque $M_{KN}$ [Nm]	1.69	2.7	3.37	5.06	6.74
Max. permissible peak torque $M_{Kmax}$ [Nm]	6.7	10.72	13.4	20.1	26.8
<b>Holding brake</b>					
Holding torque of brake $M_{Br}$ [Nm]	2.2				
Mass of brake [kg]	0.28				
Moment of inertia of brake $J_{Br}$ [kgcm <sup>2</sup> ]	0.12				
<b>Gearbox</b>					
Number of gear stages	1			2	
Gear ratio $i$	5	8	10	15	20
Nominal output torque $T_{2N}$ [Nm]	16	15		44	
Max. output torque $T_{2max}$ [Nm]	25	24		70	
Emergency switch-off torque $T_{2stop}$ [Nm]	32	30		88	
Max. average drive speed $n_{1N50\%}$ [rpm] at 50% $T_{2N}$ and S1	4500				
Max. average drive speed $n_{1N100\%}$ [rpm] at 100% $T_{2N}$ and S1	4500				
Max. backlash $J_s$ [arcmin]	10			12	
Torsional rigidity $C_{21}$ [Nm/arcmin]	2.6	2.3	2.2	2.4	2.5
Max. radial force $F_{rmax}$ [N] for 30,000 h	340				
Max. radial force $F_{rmax}$ [N] for 20,000 h	400				
Max. axial force $F_{amax}$ [N] for 30,000 h	450				
Max. axial force $F_{amax}$ [N] for 20,000 h	500				
Operating noise $L_{PA}$ [dB(A)]	58				
Efficiency at full load $\eta$ [%]	96			94	
Weight $m$ [kg]	0.57		0.58	0.75	0.76
Moment of inertia $J_1$ [kgcm <sup>2</sup> ]	0.019	0.007	0.004	0.016	0.015

## Gear ratio 025 to 100

Order number	8D1B22. elgBDMk00-1	8D1B22. elgBDNk00-1	8D1B22. elgBDQk00-1	8D1B22.elgBDTk00-1	8D1B22. elgBDWk00-1
<b>General information</b>					
Certifications					
CE	Yes				
<b>Motor</b>					
Nominal speed $n_N$ [rpm]	4500				
Number of pole pairs	5				
Nominal torque $M_n$ [Nm]	0.536				
Nominal power $P_N$ [W]	253				
Nominal current $I_N$ [A]	5.36				
Stall torque $M_0$ [Nm]	0.659				
Stall current $I_0$ [A]	6.59				
Maximum torque $M_{max}$ [Nm]	1.34				
Maximum current $I_{max}$ [A]	15.7				
Maximum speed $n_{max}$ [rpm]	6600				
Torque constant $K_T$ [Nm/A]	0.1				
Voltage constant $K_E$ [V/1000 rpm]	5.97				
Stator resistance $R_{2ph}$ [ $\Omega$ ]	0.4				
Stator inductance $L_{2ph}$ [mH]	0.37				
Electrical time constant $t_{el}$ [ms]	0.93				
Thermal time constant $t_{therm}$ [min]	35				
Moment of inertia $J$ [kgcm <sup>2</sup> ]	0.22				
Weight without brake $m$ [kg]	1.26				
Max. permissible output torque $M_{KN}$ [Nm]	8.43	10.78	13.48	21.57	33.7
Max. permissible peak torque $M_{Kmax}$ [Nm]	33.5	42.88	53.6	85.76	134
<b>Holding brake</b>					
Holding torque of brake $M_{Br}$ [Nm]	2.2				
Mass of brake [kg]	0.28				
Moment of inertia of brake $J_{Br}$ [kgcm <sup>2</sup> ]	0.12				
<b>Gearbox</b>					
Number of gear stages	2				
Gear ratio $i$	25	32	40	64	100
Nominal output torque $T_{2N}$ [Nm]	40	44	40	18	15
Max. output torque $T_{2max}$ [Nm]	64	70	64	30	24
Emergency switch-off torque $T_{2stop}$ [Nm]	80	88	80	36	30
Max. average drive speed $n_{1N50\%}$ [rpm] at 50% $T_{2N}$ and S1	4500				
Max. average drive speed $n_{1N100\%}$ [rpm] at 100% $T_{2N}$ and S1	4500				
Max. backlash $J_s$ [arcmin]	12				
Torsional rigidity $C_{t21}$ [Nm/arcmin]	2.6	2.5		2.3	2
Max. radial force $F_{rmax}$ [N] for 30,000 h	340				
Max. radial force $F_{rmax}$ [N] for 20,000 h	400				
Max. axial force $F_{amax}$ [N] for 30,000 h	450				
Max. axial force $F_{amax}$ [N] for 20,000 h	500				
Operating noise $L_{PA}$ [dB(A)]	58				
Efficiency at full load $\eta$ [%]	94				
Weight $m$ [kg]	0.77		0.78		0.96
Moment of inertia $J_1$ [kgcm <sup>2</sup> ]	0.014	0.005		0.003	

## 4.4.7.3 8D1B22.el - 4,500 rpm (8GM45, gearbox size 067) - Technical data

## Gear ratio 005 to 020

Order number	8D1B22.elgCFDk00-1	8D1B22.elgCFFk00-1	8D1B22.elgCFHk00-1	8D1B22.elgCFJk00-1	8D1B22.elgCFLk00-1
<b>General information</b>					
Certifications					
CE	Yes				
<b>Motor</b>					
Nominal speed $n_N$ [rpm]	4500				
Number of pole pairs	5				
Nominal torque $M_N$ [Nm]	0.536				
Nominal power $P_N$ [W]	253				
Nominal current $I_N$ [A]	5.36				
Stall torque $M_0$ [Nm]	0.659				
Stall current $I_0$ [A]	6.59				
Maximum torque $M_{max}$ [Nm]	1.34				
Maximum current $I_{max}$ [A]	15.7				
Maximum speed $n_{max}$ [rpm]	6600				
Torque constant $K_T$ [Nm/A]	0.1				
Voltage constant $K_E$ [V/1000 rpm]	5.97				
Stator resistance $R_{zph}$ [ $\Omega$ ]	0.4				
Stator inductance $L_{zph}$ [mH]	0.37				
Electrical time constant $t_{el}$ [ms]	0.93				
Thermal time constant $t_{therm}$ [min]	35				
Moment of inertia $J$ [kgcm <sup>2</sup> ]	0.22				
Weight without brake $m$ [kg]	1.26				
Max. permissible output torque $M_{KN}$ [Nm]	1.69	2.7	3.37	5.06	6.74
Max. permissible peak torque $M_{Kmax}$ [Nm]	6.7	10.72	13.4	20.1	26.8
<b>Holding brake</b>					
Holding torque of brake $M_{Br}$ [Nm]	2.2				
Mass of brake [kg]	0.28				
Moment of inertia of brake $J_{Br}$ [kgcm <sup>2</sup> ]	0.12				
<b>Gearbox</b>					
Number of gear stages	1			2	
Gear ratio $i$	5	8	10	15	20
Nominal output torque $T_{2N}$ [Nm]	16		15		44
Max. output torque $T_{2max}$ [Nm]	25		24		70
Emergency switch-off torque $T_{2stop}$ [Nm]	32		30		88
Max. average drive speed $n_{1N50\%}$ [rpm] at 50% $T_{2N}$ and S1	4500				
Max. average drive speed $n_{1N100\%}$ [rpm] at 100% $T_{2N}$ and S1	4500				
Max. backlash $J$ [arcmin]	10			12	
Torsional rigidity $C_{i21}$ [Nm/arcmin]	4.1	3.4	3.1	3.6	3.8
Max. radial force $F_{rmax}$ [N] for 30,000 h	700				
Max. radial force $F_{rmax}$ [N] for 20,000 h	900				
Max. axial force $F_{amax}$ [N] for 30,000 h	800				
Max. axial force $F_{amax}$ [N] for 20,000 h	1000				
Operating noise $L_{PA}$ [dB(A)]	58				
Efficiency at full load $\eta$ [%]	96			94	
Weight $m$ [kg]	0.78		0.79	0.96	0.97
Moment of inertia $J_1$ [kgcm <sup>2</sup> ]	0.024	0.008	0.005	0.016	0.015

**Gear ratio 025 to 100**

Order number	8D1B22. elgCFMk00-1	8D1B22.elgCFNk00-1	8D1B22. elgCFQk00-1	8D1B22.elgCFTk00-1	8D1B22. elgCFWk00-1
<b>General information</b>					
Certifications					
CE	Yes				
<b>Motor</b>					
Nominal speed $n_N$ [rpm]	4500				
Number of pole pairs	5				
Nominal torque $M_n$ [Nm]	0.536				
Nominal power $P_N$ [W]	253				
Nominal current $I_N$ [A]	5.36				
Stall torque $M_0$ [Nm]	0.659				
Stall current $I_0$ [A]	6.59				
Maximum torque $M_{max}$ [Nm]	1.34				
Maximum current $I_{max}$ [A]	15.7				
Maximum speed $n_{max}$ [rpm]	6600				
Torque constant $K_T$ [Nm/A]	0.1				
Voltage constant $K_E$ [V/1000 rpm]	5.97				
Stator resistance $R_{2ph}$ [ $\Omega$ ]	0.4				
Stator inductance $L_{2ph}$ [mH]	0.37				
Electrical time constant $t_{el}$ [ms]	0.93				
Thermal time constant $t_{therm}$ [min]	35				
Moment of inertia $J$ [kgcm <sup>2</sup> ]	0.22				
Weight without brake $m$ [kg]	1.26				
Max. permissible output torque $M_{KN}$ [Nm]	8.43	10.78	13.48	21.57	33.7
Max. permissible peak torque $M_{Kmax}$ [Nm]	33.5	42.88	53.6	85.76	134
<b>Holding brake</b>					
Holding torque of brake $M_{Br}$ [Nm]	2.2				
Mass of brake [kg]	0.28				
Moment of inertia of brake $J_{Br}$ [kgcm <sup>2</sup> ]	0.12				
<b>Gearbox</b>					
Number of gear stages	2				
Gear ratio $i$	25	32	40	64	100
Nominal output torque $T_{2N}$ [Nm]	40	44	40	18	15
Max. output torque $T_{2max}$ [Nm]	64	70	64	30	24
Emergency switch-off torque $T_{2stop}$ [Nm]	80	88	80	36	30
Max. average drive speed $n_{1N50\%}$ [rpm] at 50% $T_{2N}$ and S1	4500				
Max. average drive speed $n_{1N100\%}$ [rpm] at 100% $T_{2N}$ and S1	4500				
Max. backlash $J_s$ [arcmin]	12				
Torsional rigidity $C_{t21}$ [Nm/arcmin]	3.9	3.8	3.9	3.3	2.7
Max. radial force $F_{rmax}$ [N] for 30,000 h	700				
Max. radial force $F_{rmax}$ [N] for 20,000 h	900				
Max. axial force $F_{amax}$ [N] for 30,000 h	800				
Max. axial force $F_{amax}$ [N] for 20,000 h	1000				
Operating noise $L_{PA}$ [dB(A)]	58				
Efficiency at full load $\eta$ [%]	94				
Weight $m$ [kg]	0.98		0.99		1.16
Moment of inertia $J_1$ [kgcm <sup>2</sup> ]	0.014	0.006	0.005		0.003

## 4.4.7.4 8D1B22.el - 4,500 rpm (8GM50, gearbox size 070) - Technical data

## Gear ratio 005 to 020

Order number	8D1B22. elgDGDk00-1	8D1B22. elgDGFk00-1	8D1B22. elgDGHk00-1	8D1B22.elgDGJk00-1	8D1B22. elgDGLk00-1
<b>General information</b>					
Certifications					
CE	Yes				
<b>Motor</b>					
Nominal speed $n_N$ [rpm]	4500				
Number of pole pairs	5				
Nominal torque $M_N$ [Nm]	0.536				
Nominal power $P_N$ [W]	253				
Nominal current $I_N$ [A]	5.36				
Stall torque $M_0$ [Nm]	0.659				
Stall current $I_0$ [A]	6.59				
Maximum torque $M_{max}$ [Nm]	1.34				
Maximum current $I_{max}$ [A]	15.7				
Maximum speed $n_{max}$ [rpm]	6600				
Torque constant $K_T$ [Nm/A]	0.1				
Voltage constant $K_E$ [V/1000 rpm]	5.97				
Stator resistance $R_{zph}$ [ $\Omega$ ]	0.4				
Stator inductance $L_{zph}$ [mH]	0.37				
Electrical time constant $t_{el}$ [ms]	0.93				
Thermal time constant $t_{therm}$ [min]	35				
Moment of inertia $J$ [kgcm <sup>2</sup> ]	0.22				
Weight without brake $m$ [kg]	1.26				
Max. permissible output torque $M_{KN}$ [Nm]	1.69	2.7	3.37	5.06	6.74
Max. permissible peak torque $M_{Kmax}$ [Nm]	6.7	10.72	13.4	20.1	26.8
<b>Holding brake</b>					
Holding torque of brake $M_{Br}$ [Nm]	2.2				
Mass of brake [kg]	0.28				
Moment of inertia of brake $J_{Br}$ [kgcm <sup>2</sup> ]	0.12				
<b>Gearbox</b>					
Number of gear stages	1			2	
Gear ratio $i$	5	8	10	15	20
Nominal output torque $T_{2N}$ [Nm]	16	15		33	
Max. output torque $T_{2max}$ [Nm]	26	24		53	
Emergency switch-off torque $T_{2stop}$ [Nm]	32	30		66	
Max. average drive speed $n_{1N50\%}$ [rpm] at 50% $T_{2N}$ and S1	4500				
Max. average drive speed $n_{1N100\%}$ [rpm] at 100% $T_{2N}$ and S1	4500				
Max. backlash $J_s$ [arcmin]	10			12	
Torsional rigidity $C_{21}$ [Nm/arcmin]	5.7	4.4	3.9	4.9	5.2
Max. radial force $F_{rmax}$ [N] for 30,000 h	900				
Max. radial force $F_{rmax}$ [N] for 20,000 h	1050				
Max. axial force $F_{amax}$ [N] for 30,000 h	1000				
Max. axial force $F_{amax}$ [N] for 20,000 h	1350				
Operating noise $L_{PA}$ [dB(A)]	58				
Efficiency at full load $\eta$ [%]	96			94	
Weight $m$ [kg]	1.1	1.12	1.13	1.39	1.4
Moment of inertia $J_1$ [kgcm <sup>2</sup> ]	0.035	0.013	0.008	0.018	0.016

## Gear ratio 025 to 100

Order number	8D1B22. elgDGMk00-1	8D1B22. elgDGNk00-1	8D1B22. elgDGQk00-1	8D1B22. elgDGTk00-1	8D1B22. elgDGWk00-1
<b>General information</b>					
Certifications					
CE	Yes				
<b>Motor</b>					
Nominal speed $n_N$ [rpm]	4500				
Number of pole pairs	5				
Nominal torque $M_n$ [Nm]	0.536				
Nominal power $P_N$ [W]	253				
Nominal current $I_N$ [A]	5.36				
Stall torque $M_0$ [Nm]	0.659				
Stall current $I_0$ [A]	6.59				
Maximum torque $M_{max}$ [Nm]	1.34				
Maximum current $I_{max}$ [A]	15.7				
Maximum speed $n_{max}$ [rpm]	6600				
Torque constant $K_T$ [Nm/A]	0.1				
Voltage constant $K_E$ [V/1000 rpm]	5.97				
Stator resistance $R_{2ph}$ [ $\Omega$ ]	0.4				
Stator inductance $L_{2ph}$ [mH]	0.37				
Electrical time constant $t_{el}$ [ms]	0.93				
Thermal time constant $t_{therm}$ [min]	35				
Moment of inertia $J$ [kgcm <sup>2</sup> ]	0.22				
Weight without brake $m$ [kg]	1.26				
Max. permissible output torque $M_{KN}$ [Nm]	8.43	10.78	13.48	21.57	33.7
Max. permissible peak torque $M_{Kmax}$ [Nm]	33.5	42.88	53.6	85.76	134
<b>Holding brake</b>					
Holding torque of brake $M_{Br}$ [Nm]	2.2				
Mass of brake [kg]	0.28				
Moment of inertia of brake $J_{Br}$ [kgcm <sup>2</sup> ]	0.12				
<b>Gearbox</b>					
Number of gear stages	2				
Gear ratio $i$	25	32	40	64	100
Nominal output torque $T_{2N}$ [Nm]	30	33	30	18	15
Max. output torque $T_{2max}$ [Nm]	48	53	48	29	24
Emergency switch-off torque $T_{2stop}$ [Nm]	60	66	60	36	30
Max. average drive speed $n_{1N50\%}$ [rpm] at 50% $T_{2N}$ and S1	4500				
Max. average drive speed $n_{1N100\%}$ [rpm] at 100% $T_{2N}$ and S1	4500				
Max. backlash $J_s$ [arcmin]	12				
Torsional rigidity $C_{t21}$ [Nm/arcmin]	5.3	5.1	5.2	4.2	3.3
Max. radial force $F_{rmax}$ [N] for 30,000 h	900				
Max. radial force $F_{rmax}$ [N] for 20,000 h	1050				
Max. axial force $F_{amax}$ [N] for 30,000 h	1000				
Max. axial force $F_{amax}$ [N] for 20,000 h	1350				
Operating noise $L_{PA}$ [dB(A)]	58				
Efficiency at full load $\eta$ [%]	94				
Weight $m$ [kg]	1.4	1.41		1.42	1.57
Moment of inertia $J_1$ [kgcm <sup>2</sup> ]	0.015	0.006		0.005	0.003

## 4.4.7.5 8D1B22.el - 4,500 rpm (8GM55, gearbox size 060) - Technical data

## Gear ratio 005 to 020

Order number	8D1B22. elgEDDk00-1	8D1B22.elgEDFk00-1	8D1B22. elgEDHk00-1	8D1B22.elgEDJk00-1	8D1B22.elgEDLk00-1
<b>General information</b>					
Certifications					
CE	Yes				
<b>Motor</b>					
Nominal speed $n_N$ [rpm]	4500				
Number of pole pairs	5				
Nominal torque $M_N$ [Nm]	0.536				
Nominal power $P_N$ [W]	253				
Nominal current $I_N$ [A]	5.36				
Stall torque $M_0$ [Nm]	0.659				
Stall current $I_0$ [A]	6.59				
Maximum torque $M_{max}$ [Nm]	1.34				
Maximum current $I_{max}$ [A]	15.7				
Maximum speed $n_{max}$ [rpm]	6600				
Torque constant $K_T$ [Nm/A]	0.1				
Voltage constant $K_E$ [V/1000 rpm]	5.97				
Stator resistance $R_{zph}$ [ $\Omega$ ]	0.4				
Stator inductance $L_{zph}$ [mH]	0.37				
Electrical time constant $t_{el}$ [ms]	0.93				
Thermal time constant $t_{therm}$ [min]	35				
Moment of inertia $J$ [kgcm <sup>2</sup> ]	0.22				
Weight without brake $m$ [kg]	1.26				
Max. permissible output torque $M_{KN}$ [Nm]	1.93	2.7	3.37	5.06	6.74
Max. permissible peak torque $M_{Kmax}$ [Nm]	6.7	10.72	13.4	20.1	26.8
<b>Holding brake</b>					
Holding torque of brake $M_{Br}$ [Nm]	2.2				
Mass of brake [kg]	0.28				
Moment of inertia of brake $J_{Br}$ [kgcm <sup>2</sup> ]	0.12				
<b>Gearbox</b>					
Number of gear stages	1			2	
Gear ratio $i$	5	8	10	15	20
Nominal output torque $T_{2N}$ [Nm]	16	15		44	
Max. output torque $T_{2max}$ [Nm]	25	24		70	
Emergency switch-off torque $T_{2stop}$ [Nm]	32	30		88	
Max. average drive speed $n_{1N50\%}$ [rpm] at 50% $T_{2N}$ and S1	4200	4500			
Max. average drive speed $n_{1N100\%}$ [rpm] at 100% $T_{2N}$ and S1	3400	4500			
Max. backlash $J_s$ [arcmin]	10			12	
Torsional rigidity $C_{21}$ [Nm/arcmin]	4.5	3.7	3.3	3.9	4.2
Max. radial force $F_{rmax}$ [N] for 30,000 h	3200				
Max. radial force $F_{rmax}$ [N] for 20,000 h	3200				
Max. axial force $F_{amax}$ [N] for 30,000 h	3900				
Max. axial force $F_{amax}$ [N] for 20,000 h	4400				
Operating noise $L_{PA}$ [dB(A)]	58				
Efficiency at full load $\eta$ [%]	96			94	
Weight $m$ [kg]	0				
Moment of inertia $J_1$ [kgcm <sup>2</sup> ]	0.037	0.014	0.008	0.021	0.019

**Gear ratio 025 to 100**

Order number	8D1B22. elgEDMk00-1	8D1B22. elgEDNk00-1	8D1B22. elgEDQk00-1	8D1B22.elgEDTk00-1	8D1B22. elgEDWk00-1
<b>General information</b>					
Certifications					
CE	Yes				
<b>Motor</b>					
Nominal speed $n_N$ [rpm]	4500				
Number of pole pairs	5				
Nominal torque $M_n$ [Nm]	0.536				
Nominal power $P_N$ [W]	253				
Nominal current $I_N$ [A]	5.36				
Stall torque $M_0$ [Nm]	0.659				
Stall current $I_0$ [A]	6.59				
Maximum torque $M_{max}$ [Nm]	1.34				
Maximum current $I_{max}$ [A]	15.7				
Maximum speed $n_{max}$ [rpm]	6600				
Torque constant $K_T$ [Nm/A]	0.1				
Voltage constant $K_E$ [V/1000 rpm]	5.97				
Stator resistance $R_{2ph}$ [ $\Omega$ ]	0.4				
Stator inductance $L_{2ph}$ [mH]	0.37				
Electrical time constant $t_{el}$ [ms]	0.93				
Thermal time constant $t_{therm}$ [min]	35				
Moment of inertia $J$ [kgcm <sup>2</sup> ]	0.22				
Weight without brake $m$ [kg]	1.26				
Max. permissible output torque $M_{KN}$ [Nm]	8.43	10.78	13.48	21.57	33.7
Max. permissible peak torque $M_{Kmax}$ [Nm]	33.5	42.88	53.6	85.76	134
<b>Holding brake</b>					
Holding torque of brake $M_{Br}$ [Nm]	2.2				
Mass of brake [kg]	0.28				
Moment of inertia of brake $J_{Br}$ [kgcm <sup>2</sup> ]	0.12				
<b>Gearbox</b>					
Number of gear stages	2				
Gear ratio $i$	25	32	40	64	100
Nominal output torque $T_{2N}$ [Nm]	40	44	40	18	15
Max. output torque $T_{2max}$ [Nm]	64	70	64	30	24
Emergency switch-off torque $T_{2stop}$ [Nm]	80	88	80	36	30
Max. average drive speed $n_{1N50\%}$ [rpm] at 50% $T_{2N}$ and S1	4500				
Max. average drive speed $n_{1N100\%}$ [rpm] at 100% $T_{2N}$ and S1	4500				
Max. backlash $J_s$ [arcmin]	12				
Torsional rigidity $C_{t21}$ [Nm/arcmin]	4.2	4.1	4.2	3.5	2.9
Max. radial force $F_{rmax}$ [N] for 30,000 h	3200				
Max. radial force $F_{rmax}$ [N] for 20,000 h	3200				
Max. axial force $F_{amax}$ [N] for 30,000 h	3900				
Max. axial force $F_{amax}$ [N] for 20,000 h	4400				
Operating noise $L_{PA}$ [dB(A)]	58				
Efficiency at full load $\eta$ [%]	94				
Weight $m$ [kg]	0				
Moment of inertia $J_1$ [kgcm <sup>2</sup> ]	0.018	0.007		0.006	0.004

## 4.4.7.6 8D1B22.el - 4,500 rpm (8GG40, gearbox size 064) - Technical data

## Gear ratio 005 to 020

Order number	8D1B22. elgHEDk00-1	8D1B22.elgHEFk00-1	8D1B22. elgHEHk00-1	8D1B22.elgHEJk00-1	8D1B22.elgHELk00-1
<b>General information</b>					
Certifications					
CE	Yes				
<b>Motor</b>					
Nominal speed $n_N$ [rpm]	4500				
Number of pole pairs	5				
Nominal torque $M_N$ [Nm]	0.536				
Nominal power $P_N$ [W]	253				
Nominal current $I_N$ [A]	5.36				
Stall torque $M_0$ [Nm]	0.659				
Stall current $I_0$ [A]	6.59				
Maximum torque $M_{max}$ [Nm]	1.34				
Maximum current $I_{max}$ [A]	15.7				
Maximum speed $n_{max}$ [rpm]	6600				
Torque constant $K_T$ [Nm/A]	0.1				
Voltage constant $K_E$ [V/1000 rpm]	5.97				
Stator resistance $R_{zph}$ [ $\Omega$ ]	0.4				
Stator inductance $L_{zph}$ [mH]	0.37				
Electrical time constant $t_{el}$ [ms]	0.93				
Thermal time constant $t_{therm}$ [min]	35				
Moment of inertia $J$ [kgcm <sup>2</sup> ]	0.22				
Weight without brake $m$ [kg]	1.26				
Max. permissible output torque $M_{KN}$ [Nm]	1.8	2.7	3.37	5.06	6.74
Max. permissible peak torque $M_{Kmax}$ [Nm]	6.7	10.72	13.4	20.1	26.8
<b>Holding brake</b>					
Holding torque of brake $M_{Br}$ [Nm]	2.2				
Mass of brake [kg]	0.28				
Moment of inertia of brake $J_{Br}$ [kgcm <sup>2</sup> ]	0.12				
<b>Gearbox</b>					
Number of gear stages	1			2	
Gear ratio $i$	5	8	10	15	20
Nominal output torque $T_{2N}$ [Nm]	16	15		44	
Max. output torque $T_{2max}$ [Nm]	25	24		70	
Emergency switch-off torque $T_{2stop}$ [Nm]	32	30		88	
Max. average drive speed $n_{1N50\%}$ [rpm] at 50% $T_{2N}$ and S1	4500				
Max. average drive speed $n_{1N100\%}$ [rpm] at 100% $T_{2N}$ and S1	4000	4500			
Max. backlash $J_s$ [arcmin]	10			12	
Torsional rigidity $C_{21}$ [Nm/arcmin]	14.2	8.2	6.4	10.2	11.7
Max. radial force $F_{rmax}$ [N] for 30,000 h	500				
Max. radial force $F_{rmax}$ [N] for 20,000 h	550				
Max. axial force $F_{amax}$ [N] for 30,000 h	1200				
Max. axial force $F_{amax}$ [N] for 20,000 h	1200				
Operating noise $L_{PA}$ [dB(A)]	58				
Efficiency at full load $\eta$ [%]	96			94	
Weight $m$ [kg]	0.78		0.79	1	1.02
Moment of inertia $J_1$ [kgcm <sup>2</sup> ]	0.049	0.018	0.011	0.019	0.017

**Gear ratio 025 to 100**

Order number	8D1B22. elgHEMk00-1	8D1B22. elgHENk00-1	8D1B22. elgHEQk00-1	8D1B22.elgHETk00-1	8D1B22. elgHEWk00-1
<b>General information</b>					
Certifications					
CE	Yes				
<b>Motor</b>					
Nominal speed $n_N$ [rpm]	4500				
Number of pole pairs	5				
Nominal torque $M_n$ [Nm]	0.536				
Nominal power $P_N$ [W]	253				
Nominal current $I_N$ [A]	5.36				
Stall torque $M_0$ [Nm]	0.659				
Stall current $I_0$ [A]	6.59				
Maximum torque $M_{max}$ [Nm]	1.34				
Maximum current $I_{max}$ [A]	15.7				
Maximum speed $n_{max}$ [rpm]	6600				
Torque constant $K_T$ [Nm/A]	0.1				
Voltage constant $K_E$ [V/1000 rpm]	5.97				
Stator resistance $R_{2ph}$ [ $\Omega$ ]	0.4				
Stator inductance $L_{2ph}$ [mH]	0.37				
Electrical time constant $t_{el}$ [ms]	0.93				
Thermal time constant $t_{therm}$ [min]	35				
Moment of inertia $J$ [kgcm <sup>2</sup> ]	0.22				
Weight without brake $m$ [kg]	1.26				
Max. permissible output torque $M_{KN}$ [Nm]	8.43	10.78	13.48	21.57	33.7
Max. permissible peak torque $M_{Kmax}$ [Nm]	33.5	42.88	53.6	85.76	134
<b>Holding brake</b>					
Holding torque of brake $M_{Br}$ [Nm]	2.2				
Mass of brake [kg]	0.28				
Moment of inertia of brake $J_{Br}$ [kgcm <sup>2</sup> ]	0.12				
<b>Gearbox</b>					
Number of gear stages	2				
Gear ratio $i$	25	32	40	64	100
Nominal output torque $T_{2N}$ [Nm]	40	44	40	18	15
Max. output torque $T_{2max}$ [Nm]	64	70	64	30	24
Emergency switch-off torque $T_{2stop}$ [Nm]	80	88	80	36	30
Max. average drive speed $n_{1N50\%}$ [rpm] at 50% $T_{2N}$ and S1	4500				
Max. average drive speed $n_{1N100\%}$ [rpm] at 100% $T_{2N}$ and S1	4500				
Max. backlash $J_s$ [arcmin]	12				
Torsional rigidity $C_{t21}$ [Nm/arcmin]	12	11.4	11.8	7.5	5.1
Max. radial force $F_{rmax}$ [N] for 30,000 h	500				
Max. radial force $F_{rmax}$ [N] for 20,000 h	550				
Max. axial force $F_{amax}$ [N] for 30,000 h	1200				
Max. axial force $F_{amax}$ [N] for 20,000 h	1200				
Operating noise $L_{PA}$ [dB(A)]	58				
Efficiency at full load $\eta$ [%]	94				
Weight $m$ [kg]	1.02	1.03	1.04	1.03	1.09
Moment of inertia $J_1$ [kgcm <sup>2</sup> ]	0.015	0.006		0.005	0.003

## 4.4.7.7 8D1B23.eD - 2,000 rpm (8GM40, gearbox size 060) - Technical data

## Gear ratio 005 to 020

Order number	8D1B23. eDgBDDk00-1	8D1B23. eDgBDFk00-1	8D1B23. eDgBDHk00-1	8D1B23. eDgBDJk00-1	8D1B23. eDgBDLk00-1
<b>General information</b>					
Certifications					
CE	Yes				
<b>Motor</b>					
Nominal speed $n_N$ [rpm]	2000				
Number of pole pairs	5				
Nominal torque $M_N$ [Nm]	1.047				
Nominal power $P_N$ [W]	219				
Nominal current $I_N$ [A]	4.76				
Stall torque $M_0$ [Nm]	1.118				
Stall current $I_0$ [A]	5.08				
Maximum torque $M_{max}$ [Nm]	3.01				
Maximum current $I_{max}$ [A]	15.7				
Maximum speed $n_{max}$ [rpm]	6600				
Torque constant $K_T$ [Nm/A]	0.22				
Voltage constant $K_E$ [V/1000 rpm]	13.41				
Stator resistance $R_{zph}$ [ $\Omega$ ]	0.76				
Stator inductance $L_{zph}$ [mH]	0.93				
Electrical time constant $t_{el}$ [ms]	1.2				
Thermal time constant $t_{therm}$ [min]	38				
Moment of inertia $J$ [kgcm <sup>2</sup> ]	0.41				
Weight without brake $m$ [kg]	1.62				
Max. permissible output torque $M_{KN}$ [Nm]	1.69	2.7	3.37	5.06	6.74
Max. permissible peak torque $M_{Kmax}$ [Nm]	6.7	10.72	13.4	20.1	26.8
<b>Holding brake</b>					
Holding torque of brake $M_{Br}$ [Nm]	2.2				
Mass of brake [kg]	0.28				
Moment of inertia of brake $J_{Br}$ [kgcm <sup>2</sup> ]	0.12				
<b>Gearbox</b>					
Number of gear stages	1			2	
Gear ratio $i$	5	8	10	15	20
Nominal output torque $T_{2N}$ [Nm]	16	15		44	
Max. output torque $T_{2max}$ [Nm]	25	24		70	
Emergency switch-off torque $T_{2stop}$ [Nm]	32	30		88	
Max. average drive speed $n_{1N50\%}$ [rpm] at 50% $T_{2N}$ and S1	4500				
Max. average drive speed $n_{1N100\%}$ [rpm] at 100% $T_{2N}$ and S1	4500				
Max. backlash $J_s$ [arcmin]	10			12	
Torsional rigidity $C_{21}$ [Nm/arcmin]	2.6	2.3	2.2	2.4	2.5
Max. radial force $F_{rmax}$ [N] for 30,000 h	340				
Max. radial force $F_{rmax}$ [N] for 20,000 h	400				
Max. axial force $F_{amax}$ [N] for 30,000 h	450				
Max. axial force $F_{amax}$ [N] for 20,000 h	500				
Operating noise $L_{PA}$ [dB(A)]	58				
Efficiency at full load $\eta$ [%]	96			94	
Weight $m$ [kg]	0.57		0.58	0.75	0.76
Moment of inertia $J_1$ [kgcm <sup>2</sup> ]	0.019	0.007	0.004	0.016	0.015

## Gear ratio 025 to 100

Order number	8D1B23. eDgBDMk00-1	8D1B23. eDgBDNk00-1	8D1B23. eDgBDQk00-1	8D1B23. eDgBDTk00-1	8D1B23. eDgBDWk00-1
<b>General information</b>					
Certifications					
CE	Yes				
<b>Motor</b>					
Nominal speed $n_N$ [rpm]	2000				
Number of pole pairs	5				
Nominal torque $M_n$ [Nm]	1.047				
Nominal power $P_N$ [W]	219				
Nominal current $I_N$ [A]	4.76				
Stall torque $M_0$ [Nm]	1.118				
Stall current $I_0$ [A]	5.08				
Maximum torque $M_{max}$ [Nm]	3.01				
Maximum current $I_{max}$ [A]	15.7				
Maximum speed $n_{max}$ [rpm]	6600				
Torque constant $K_T$ [Nm/A]	0.22				
Voltage constant $K_E$ [V/1000 rpm]	13.41				
Stator resistance $R_{2ph}$ [ $\Omega$ ]	0.76				
Stator inductance $L_{2ph}$ [mH]	0.93				
Electrical time constant $t_{el}$ [ms]	1.2				
Thermal time constant $t_{therm}$ [min]	38				
Moment of inertia $J$ [kgcm <sup>2</sup> ]	0.41				
Weight without brake $m$ [kg]	1.62				
Max. permissible output torque $M_{KN}$ [Nm]	8.43	10.78	13.48	21.57	33.7
Max. permissible peak torque $M_{Kmax}$ [Nm]	33.5	42.88	53.6	85.76	134
<b>Holding brake</b>					
Holding torque of brake $M_{Br}$ [Nm]	2.2				
Mass of brake [kg]	0.28				
Moment of inertia of brake $J_{Br}$ [kgcm <sup>2</sup> ]	0.12				
<b>Gearbox</b>					
Number of gear stages	2				
Gear ratio $i$	25	32	40	64	100
Nominal output torque $T_{2N}$ [Nm]	40	44	40	18	15
Max. output torque $T_{2max}$ [Nm]	64	70	64	30	24
Emergency switch-off torque $T_{2stop}$ [Nm]	80	88	80	36	30
Max. average drive speed $n_{1N50\%}$ [rpm] at 50% $T_{2N}$ and S1	4500				
Max. average drive speed $n_{1N100\%}$ [rpm] at 100% $T_{2N}$ and S1	4500				
Max. backlash $J_s$ [arcmin]	12				
Torsional rigidity $C_{t21}$ [Nm/arcmin]	2.6	2.5		2.3	2
Max. radial force $F_{rmax}$ [N] for 30,000 h	340				
Max. radial force $F_{rmax}$ [N] for 20,000 h	400				
Max. axial force $F_{amax}$ [N] for 30,000 h	450				
Max. axial force $F_{amax}$ [N] for 20,000 h	500				
Operating noise $L_{PA}$ [dB(A)]	58				
Efficiency at full load $\eta$ [%]	94				
Weight $m$ [kg]	0.77		0.78		0.96
Moment of inertia $J_1$ [kgcm <sup>2</sup> ]	0.014	0.005		0.003	

## 4.4.7.8 8D1B23.eD - 2,000 rpm (8GM45, gearbox size 067) - Technical data

## Gear ratio 005 to 020

Order number	8D1B23. eDgCFDk00-1	8D1B23. eDgCFFk00-1	8D1B23. eDgCFHk00-1	8D1B23. eDgCFJk00-1	8D1B23. eDgCFLk00-1
<b>General information</b>					
Certifications					
CE	Yes				
<b>Motor</b>					
Nominal speed $n_N$ [rpm]	2000				
Number of pole pairs	5				
Nominal torque $M_N$ [Nm]	1.047				
Nominal power $P_N$ [W]	219				
Nominal current $I_N$ [A]	4.76				
Stall torque $M_0$ [Nm]	1.118				
Stall current $I_0$ [A]	5.08				
Maximum torque $M_{max}$ [Nm]	3.01				
Maximum current $I_{max}$ [A]	15.7				
Maximum speed $n_{max}$ [rpm]	6600				
Torque constant $K_T$ [Nm/A]	0.22				
Voltage constant $K_E$ [V/1000 rpm]	13.41				
Stator resistance $R_{zph}$ [ $\Omega$ ]	0.76				
Stator inductance $L_{zph}$ [mH]	0.93				
Electrical time constant $t_{el}$ [ms]	1.2				
Thermal time constant $t_{therm}$ [min]	38				
Moment of inertia $J$ [kgcm <sup>2</sup> ]	0.41				
Weight without brake $m$ [kg]	1.62				
Max. permissible output torque $M_{KN}$ [Nm]	1.69	2.7	3.37	5.06	6.74
Max. permissible peak torque $M_{Kmax}$ [Nm]	6.7	10.72	13.4	20.1	26.8
<b>Holding brake</b>					
Holding torque of brake $M_{Br}$ [Nm]	2.2				
Mass of brake [kg]	0.28				
Moment of inertia of brake $J_{Br}$ [kgcm <sup>2</sup> ]	0.12				
<b>Gearbox</b>					
Number of gear stages	1			2	
Gear ratio $i$	5	8	10	15	20
Nominal output torque $T_{2N}$ [Nm]	16	15		44	
Max. output torque $T_{2max}$ [Nm]	25	24		70	
Emergency switch-off torque $T_{2stop}$ [Nm]	32	30		88	
Max. average drive speed $n_{1N50\%}$ [rpm] at 50% $T_{2N}$ and S1	4500				
Max. average drive speed $n_{1N100\%}$ [rpm] at 100% $T_{2N}$ and S1	4500				
Max. backlash $J_s$ [arcmin]	10			12	
Torsional rigidity $C_{21}$ [Nm/arcmin]	4.1	3.4	3.1	3.6	3.8
Max. radial force $F_{rmax}$ [N] for 30,000 h	700				
Max. radial force $F_{rmax}$ [N] for 20,000 h	900				
Max. axial force $F_{amax}$ [N] for 30,000 h	800				
Max. axial force $F_{amax}$ [N] for 20,000 h	1000				
Operating noise $L_{PA}$ [dB(A)]	58				
Efficiency at full load $\eta$ [%]	96			94	
Weight $m$ [kg]	0.78		0.79	0.96	0.97
Moment of inertia $J_1$ [kgcm <sup>2</sup> ]	0.024	0.008	0.005	0.016	0.015

## Gear ratio 025 to 100

Order number	8D1B23. eDgCFMk00-1	8D1B23. eDgCFNk00-1	8D1B23. eDgCFQk00-1	8D1B23. eDgCFTk00-1	8D1B23. eDgCFWk00-1
<b>General information</b>					
Certifications					
CE	Yes				
<b>Motor</b>					
Nominal speed $n_N$ [rpm]	2000				
Number of pole pairs	5				
Nominal torque $M_n$ [Nm]	1.047				
Nominal power $P_N$ [W]	219				
Nominal current $I_N$ [A]	4.76				
Stall torque $M_0$ [Nm]	1.118				
Stall current $I_0$ [A]	5.08				
Maximum torque $M_{max}$ [Nm]	3.01				
Maximum current $I_{max}$ [A]	15.7				
Maximum speed $n_{max}$ [rpm]	6600				
Torque constant $K_T$ [Nm/A]	0.22				
Voltage constant $K_E$ [V/1000 rpm]	13.41				
Stator resistance $R_{2ph}$ [ $\Omega$ ]	0.76				
Stator inductance $L_{2ph}$ [mH]	0.93				
Electrical time constant $t_{el}$ [ms]	1.2				
Thermal time constant $t_{therm}$ [min]	38				
Moment of inertia $J$ [kgcm <sup>2</sup> ]	0.41				
Weight without brake $m$ [kg]	1.62				
Max. permissible output torque $M_{KN}$ [Nm]	8.43	10.78	13.48	21.57	33.7
Max. permissible peak torque $M_{Kmax}$ [Nm]	33.5	42.88	53.6	85.76	134
<b>Holding brake</b>					
Holding torque of brake $M_{Br}$ [Nm]	2.2				
Mass of brake [kg]	0.28				
Moment of inertia of brake $J_{Br}$ [kgcm <sup>2</sup> ]	0.12				
<b>Gearbox</b>					
Number of gear stages	2				
Gear ratio $i$	25	32	40	64	100
Nominal output torque $T_{2N}$ [Nm]	40	44	40	18	15
Max. output torque $T_{2max}$ [Nm]	64	70	64	30	24
Emergency switch-off torque $T_{2stop}$ [Nm]	80	88	80	36	30
Max. average drive speed $n_{1N50\%}$ [rpm] at 50% $T_{2N}$ and S1	4500				
Max. average drive speed $n_{1N100\%}$ [rpm] at 100% $T_{2N}$ and S1	4500				
Max. backlash $J_s$ [arcmin]	12				
Torsional rigidity $C_{t21}$ [Nm/arcmin]	3.9	3.8	3.9	3.3	2.7
Max. radial force $F_{rmax}$ [N] for 30,000 h	700				
Max. radial force $F_{rmax}$ [N] for 20,000 h	900				
Max. axial force $F_{amax}$ [N] for 30,000 h	800				
Max. axial force $F_{amax}$ [N] for 20,000 h	1000				
Operating noise $L_{PA}$ [dB(A)]	58				
Efficiency at full load $\eta$ [%]	94				
Weight $m$ [kg]	0.98		0.99		1.16
Moment of inertia $J_1$ [kgcm <sup>2</sup> ]	0.014	0.006	0.005		0.003

## 4.4.7.9 8D1B23.eD - 2,000 rpm (8GM50, gearbox size 070) - Technical data

## Gear ratio 005 to 020

Order number	8D1B23. eDgDGDk00-1	8D1B23. eDgDGFk00-1	8D1B23. eDgDGHk00-1	8D1B23. eDgDGJk00-1	8D1B23. eDgDGLk00-1
<b>General information</b>					
Certifications					
CE	Yes				
<b>Motor</b>					
Nominal speed $n_N$ [rpm]	2000				
Number of pole pairs	5				
Nominal torque $M_N$ [Nm]	1.047				
Nominal power $P_N$ [W]	219				
Nominal current $I_N$ [A]	4.76				
Stall torque $M_0$ [Nm]	1.118				
Stall current $I_0$ [A]	5.08				
Maximum torque $M_{max}$ [Nm]	3.01				
Maximum current $I_{max}$ [A]	15.7				
Maximum speed $n_{max}$ [rpm]	6600				
Torque constant $K_T$ [Nm/A]	0.22				
Voltage constant $K_E$ [V/1000 rpm]	13.41				
Stator resistance $R_{zph}$ [ $\Omega$ ]	0.76				
Stator inductance $L_{zph}$ [mH]	0.93				
Electrical time constant $t_{el}$ [ms]	1.2				
Thermal time constant $t_{therm}$ [min]	38				
Moment of inertia $J$ [kgcm <sup>2</sup> ]	0.41				
Weight without brake $m$ [kg]	1.62				
Max. permissible output torque $M_{KN}$ [Nm]	1.69	2.7	3.37	5.06	6.74
Max. permissible peak torque $M_{Kmax}$ [Nm]	6.7	10.72	13.4	20.1	26.8
<b>Holding brake</b>					
Holding torque of brake $M_{Br}$ [Nm]	2.2				
Mass of brake [kg]	0.28				
Moment of inertia of brake $J_{Br}$ [kgcm <sup>2</sup> ]	0.12				
<b>Gearbox</b>					
Number of gear stages	1			2	
Gear ratio $i$	5	8	10	15	20
Nominal output torque $T_{2N}$ [Nm]	16	15		33	
Max. output torque $T_{2max}$ [Nm]	26	24		53	
Emergency switch-off torque $T_{2stop}$ [Nm]	32	30		66	
Max. average drive speed $n_{1N50\%}$ [rpm] at 50% $T_{2N}$ and S1	4500				
Max. average drive speed $n_{1N100\%}$ [rpm] at 100% $T_{2N}$ and S1	4500				
Max. backlash $J_s$ [arcmin]	10			12	
Torsional rigidity $C_{21}$ [Nm/arcmin]	5.7	4.4	3.9	4.9	5.2
Max. radial force $F_{rmax}$ [N] for 30,000 h	900				
Max. radial force $F_{rmax}$ [N] for 20,000 h	1050				
Max. axial force $F_{amax}$ [N] for 30,000 h	1000				
Max. axial force $F_{amax}$ [N] for 20,000 h	1350				
Operating noise $L_{PA}$ [dB(A)]	58				
Efficiency at full load $\eta$ [%]	96			94	
Weight $m$ [kg]	1.1	1.12	1.13	1.39	1.4
Moment of inertia $J_1$ [kgcm <sup>2</sup> ]	0.035	0.013	0.008	0.018	0.016

## Gear ratio 025 to 100

Order number	8D1B23. eDgDGMk00-1	8D1B23. eDgDGNk00-1	8D1B23. eDgDGQk00-1	8D1B23. eDgDGTk00-1	8D1B23. eDgDGWk00-1
<b>General information</b>					
Certifications					
CE	Yes				
<b>Motor</b>					
Nominal speed $n_N$ [rpm]	2000				
Number of pole pairs	5				
Nominal torque $M_n$ [Nm]	1.047				
Nominal power $P_N$ [W]	219				
Nominal current $I_N$ [A]	4.76				
Stall torque $M_0$ [Nm]	1.118				
Stall current $I_0$ [A]	5.08				
Maximum torque $M_{max}$ [Nm]	3.01				
Maximum current $I_{max}$ [A]	15.7				
Maximum speed $n_{max}$ [rpm]	6600				
Torque constant $K_T$ [Nm/A]	0.22				
Voltage constant $K_E$ [V/1000 rpm]	13.41				
Stator resistance $R_{2ph}$ [ $\Omega$ ]	0.76				
Stator inductance $L_{2ph}$ [mH]	0.93				
Electrical time constant $t_{el}$ [ms]	1.2				
Thermal time constant $t_{therm}$ [min]	38				
Moment of inertia $J$ [kgcm <sup>2</sup> ]	0.41				
Weight without brake $m$ [kg]	1.62				
Max. permissible output torque $M_{KN}$ [Nm]	8.43	10.78	13.48	21.57	33.7
Max. permissible peak torque $M_{Kmax}$ [Nm]	33.5	42.88	53.6	85.76	134
<b>Holding brake</b>					
Holding torque of brake $M_{Br}$ [Nm]	2.2				
Mass of brake [kg]	0.28				
Moment of inertia of brake $J_{Br}$ [kgcm <sup>2</sup> ]	0.12				
<b>Gearbox</b>					
Number of gear stages	2				
Gear ratio $i$	25	32	40	64	100
Nominal output torque $T_{2N}$ [Nm]	30	33	30	18	15
Max. output torque $T_{2max}$ [Nm]	48	53	48	29	24
Emergency switch-off torque $T_{2stop}$ [Nm]	60	66	60	36	30
Max. average drive speed $n_{1N50\%}$ [rpm] at 50% $T_{2N}$ and S1	4500				
Max. average drive speed $n_{1N100\%}$ [rpm] at 100% $T_{2N}$ and S1	4500				
Max. backlash $J_s$ [arcmin]	12				
Torsional rigidity $C_{t21}$ [Nm/arcmin]	5.3	5.1	5.2	4.2	3.3
Max. radial force $F_{rmax}$ [N] for 30,000 h	900				
Max. radial force $F_{rmax}$ [N] for 20,000 h	1050				
Max. axial force $F_{amax}$ [N] for 30,000 h	1000				
Max. axial force $F_{amax}$ [N] for 20,000 h	1350				
Operating noise $L_{PA}$ [dB(A)]	58				
Efficiency at full load $\eta$ [%]	94				
Weight $m$ [kg]	1.4	1.41		1.42	1.57
Moment of inertia $J_1$ [kgcm <sup>2</sup> ]	0.015	0.006		0.005	0.003

## 4.4.7.10 8D1B23.eD - 2,000 rpm (8GM55, gearbox size 060) - Technical data

## Gear ratio 005 to 020

Order number	8D1B23. eDgEDDk00-1	8D1B23. eDgEDFk00-1	8D1B23. eDgEDHk00-1	8D1B23. eDgEDJk00-1	8D1B23. eDgEDLk00-1
<b>General information</b>					
Certifications					
CE	Yes				
<b>Motor</b>					
Nominal speed $n_N$ [rpm]	2000				
Number of pole pairs	5				
Nominal torque $M_N$ [Nm]	1.047				
Nominal power $P_N$ [W]	219				
Nominal current $I_N$ [A]	4.76				
Stall torque $M_0$ [Nm]	1.118				
Stall current $I_0$ [A]	5.08				
Maximum torque $M_{max}$ [Nm]	3.01				
Maximum current $I_{max}$ [A]	15.7				
Maximum speed $n_{max}$ [rpm]	6600				
Torque constant $K_T$ [Nm/A]	0.22				
Voltage constant $K_E$ [V/1000 rpm]	13.41				
Stator resistance $R_{zph}$ [ $\Omega$ ]	0.76				
Stator inductance $L_{zph}$ [mH]	0.93				
Electrical time constant $t_{el}$ [ms]	1.2				
Thermal time constant $t_{therm}$ [min]	38				
Moment of inertia $J$ [kgcm <sup>2</sup> ]	0.41				
Weight without brake $m$ [kg]	1.62				
Max. permissible output torque $M_{KN}$ [Nm]	1.93	2.7	3.37	5.06	6.74
Max. permissible peak torque $M_{Kmax}$ [Nm]	6.7	10.72	13.4	20.1	26.8
<b>Holding brake</b>					
Holding torque of brake $M_{Br}$ [Nm]	2.2				
Mass of brake [kg]	0.28				
Moment of inertia of brake $J_{Br}$ [kgcm <sup>2</sup> ]	0.12				
<b>Gearbox</b>					
Number of gear stages	1			2	
Gear ratio $i$	5	8	10	15	20
Nominal output torque $T_{2N}$ [Nm]	16	15		44	
Max. output torque $T_{2max}$ [Nm]	25	24		70	
Emergency switch-off torque $T_{2stop}$ [Nm]	32	30		88	
Max. average drive speed $n_{1N50\%}$ [rpm] at 50% $T_{2N}$ and S1	4200	4500			
Max. average drive speed $n_{1N100\%}$ [rpm] at 100% $T_{2N}$ and S1	3400	4500			
Max. backlash $J_s$ [arcmin]	10			12	
Torsional rigidity $C_{21}$ [Nm/arcmin]	4.5	3.7	3.3	3.9	4.2
Max. radial force $F_{rmax}$ [N] for 30,000 h	3200				
Max. radial force $F_{rmax}$ [N] for 20,000 h	3200				
Max. axial force $F_{amax}$ [N] for 30,000 h	3900				
Max. axial force $F_{amax}$ [N] for 20,000 h	4400				
Operating noise $L_{PA}$ [dB(A)]	58				
Efficiency at full load $\eta$ [%]	96			94	
Weight $m$ [kg]	0				
Moment of inertia $J_1$ [kgcm <sup>2</sup> ]	0.037	0.014	0.008	0.021	0.019

## Gear ratio 025 to 100

Order number	8D1B23. eDgEDMk00-1	8D1B23. eDgEDNk00-1	8D1B23. eDgEDQk00-1	8D1B23. eDgEDTk00-1	8D1B23. eDgEDWk00-1
<b>General information</b>					
Certifications					
CE	Yes				
<b>Motor</b>					
Nominal speed $n_N$ [rpm]	2000				
Number of pole pairs	5				
Nominal torque $M_n$ [Nm]	1.047				
Nominal power $P_N$ [W]	219				
Nominal current $I_N$ [A]	4.76				
Stall torque $M_0$ [Nm]	1.118				
Stall current $I_0$ [A]	5.08				
Maximum torque $M_{max}$ [Nm]	3.01				
Maximum current $I_{max}$ [A]	15.7				
Maximum speed $n_{max}$ [rpm]	6600				
Torque constant $K_T$ [Nm/A]	0.22				
Voltage constant $K_E$ [V/1000 rpm]	13.41				
Stator resistance $R_{2ph}$ [ $\Omega$ ]	0.76				
Stator inductance $L_{2ph}$ [mH]	0.93				
Electrical time constant $t_{el}$ [ms]	1.2				
Thermal time constant $t_{therm}$ [min]	38				
Moment of inertia $J$ [kgcm <sup>2</sup> ]	0.41				
Weight without brake $m$ [kg]	1.62				
Max. permissible output torque $M_{KN}$ [Nm]	8.43	10.78	13.48	21.57	33.7
Max. permissible peak torque $M_{Kmax}$ [Nm]	33.5	42.88	53.6	85.76	134
<b>Holding brake</b>					
Holding torque of brake $M_{Br}$ [Nm]	2.2				
Mass of brake [kg]	0.28				
Moment of inertia of brake $J_{Br}$ [kgcm <sup>2</sup> ]	0.12				
<b>Gearbox</b>					
Number of gear stages	2				
Gear ratio $i$	25	32	40	64	100
Nominal output torque $T_{2N}$ [Nm]	40	44	40	18	15
Max. output torque $T_{2max}$ [Nm]	64	70	64	30	24
Emergency switch-off torque $T_{2stop}$ [Nm]	80	88	80	36	30
Max. average drive speed $n_{1N50\%}$ [rpm] at 50% $T_{2N}$ and S1	4500				
Max. average drive speed $n_{1N100\%}$ [rpm] at 100% $T_{2N}$ and S1	4500				
Max. backlash $J_1$ [arcmin]	12				
Torsional rigidity $C_{121}$ [Nm/arcmin]	4.2	4.1	4.2	3.5	2.9
Max. radial force $F_{rmax}$ [N] for 30,000 h	3200				
Max. radial force $F_{rmax}$ [N] for 20,000 h	3200				
Max. axial force $F_{amax}$ [N] for 30,000 h	3900				
Max. axial force $F_{amax}$ [N] for 20,000 h	4400				
Operating noise $L_{PA}$ [dB(A)]	58				
Efficiency at full load $\eta$ [%]	94				
Weight $m$ [kg]	0				
Moment of inertia $J_1$ [kgcm <sup>2</sup> ]	0.018	0.007		0.006	0.004

## 4.4.7.11 8D1B23.eD - 2,000 rpm (8GG40, gearbox size 064) - Technical data

## Gear ratio 005 to 020

Order number	8D1B23. eDgHEDk00-1	8D1B23. eDgHEFk00-1	8D1B23. eDgHEHk00-1	8D1B23. eDgHEJk00-1	8D1B23. eDgHELk00-1
<b>General information</b>					
Certifications					
CE	Yes				
<b>Motor</b>					
Nominal speed $n_N$ [rpm]	2000				
Number of pole pairs	5				
Nominal torque $M_N$ [Nm]	1.047				
Nominal power $P_N$ [W]	219				
Nominal current $I_N$ [A]	4.76				
Stall torque $M_0$ [Nm]	1.118				
Stall current $I_0$ [A]	5.08				
Maximum torque $M_{max}$ [Nm]	3.01				
Maximum current $I_{max}$ [A]	15.7				
Maximum speed $n_{max}$ [rpm]	6600				
Torque constant $K_T$ [Nm/A]	0.22				
Voltage constant $K_E$ [V/1000 rpm]	13.41				
Stator resistance $R_{zph}$ [ $\Omega$ ]	0.76				
Stator inductance $L_{zph}$ [mH]	0.93				
Electrical time constant $t_{el}$ [ms]	1.2				
Thermal time constant $t_{therm}$ [min]	38				
Moment of inertia $J$ [kgcm <sup>2</sup> ]	0.41				
Weight without brake $m$ [kg]	1.62				
Max. permissible output torque $M_{KN}$ [Nm]	1.8	2.7	3.37	5.06	6.74
Max. permissible peak torque $M_{Kmax}$ [Nm]	6.7	10.72	13.4	20.1	26.8
<b>Holding brake</b>					
Holding torque of brake $M_{Br}$ [Nm]	2.2				
Mass of brake [kg]	0.28				
Moment of inertia of brake $J_{Br}$ [kgcm <sup>2</sup> ]	0.12				
<b>Gearbox</b>					
Number of gear stages	1			2	
Gear ratio $i$	5	8	10	15	20
Nominal output torque $T_{2N}$ [Nm]	16	15		44	
Max. output torque $T_{2max}$ [Nm]	25	24		70	
Emergency switch-off torque $T_{2stop}$ [Nm]	32	30		88	
Max. average drive speed $n_{1N50\%}$ [rpm] at 50% $T_{2N}$ and S1	4500				
Max. average drive speed $n_{1N100\%}$ [rpm] at 100% $T_{2N}$ and S1	4000	4500			
Max. backlash $J_s$ [arcmin]	10			12	
Torsional rigidity $C_{21}$ [Nm/arcmin]	14.2	8.2	6.4	10.2	11.7
Max. radial force $F_{rmax}$ [N] for 30,000 h	500				
Max. radial force $F_{rmax}$ [N] for 20,000 h	550				
Max. axial force $F_{amax}$ [N] for 30,000 h	1200				
Max. axial force $F_{amax}$ [N] for 20,000 h	1200				
Operating noise $L_{PA}$ [dB(A)]	58				
Efficiency at full load $\eta$ [%]	96			94	
Weight $m$ [kg]	0.78		0.79	1	1.02
Moment of inertia $J_1$ [kgcm <sup>2</sup> ]	0.049	0.018	0.011	0.019	0.017

**Gear ratio 025 to 100**

Order number	8D1B23. eDgHEMk00-1	8D1B23. eDgHENk00-1	8D1B23. eDgHEQk00-1	8D1B23. eDgHETk00-1	8D1B23. eDgHEWk00-1
<b>General information</b>					
Certifications					
CE	Yes				
<b>Motor</b>					
Nominal speed $n_N$ [rpm]	2000				
Number of pole pairs	5				
Nominal torque $M_n$ [Nm]	1.047				
Nominal power $P_N$ [W]	219				
Nominal current $I_N$ [A]	4.76				
Stall torque $M_0$ [Nm]	1.118				
Stall current $I_0$ [A]	5.08				
Maximum torque $M_{max}$ [Nm]	3.01				
Maximum current $I_{max}$ [A]	15.7				
Maximum speed $n_{max}$ [rpm]	6600				
Torque constant $K_T$ [Nm/A]	0.22				
Voltage constant $K_E$ [V/1000 rpm]	13.41				
Stator resistance $R_{2ph}$ [ $\Omega$ ]	0.76				
Stator inductance $L_{2ph}$ [mH]	0.93				
Electrical time constant $t_{el}$ [ms]	1.2				
Thermal time constant $t_{therm}$ [min]	38				
Moment of inertia $J$ [kgcm <sup>2</sup> ]	0.41				
Weight without brake $m$ [kg]	1.62				
Max. permissible output torque $M_{KN}$ [Nm]	8.43	10.78	13.48	21.57	33.7
Max. permissible peak torque $M_{Kmax}$ [Nm]	33.5	42.88	53.6	85.76	134
<b>Holding brake</b>					
Holding torque of brake $M_{Br}$ [Nm]	2.2				
Mass of brake [kg]	0.28				
Moment of inertia of brake $J_{Br}$ [kgcm <sup>2</sup> ]	0.12				
<b>Gearbox</b>					
Number of gear stages	2				
Gear ratio $i$	25	32	40	64	100
Nominal output torque $T_{2N}$ [Nm]	40	44	40	18	15
Max. output torque $T_{2max}$ [Nm]	64	70	64	30	24
Emergency switch-off torque $T_{2stop}$ [Nm]	80	88	80	36	30
Max. average drive speed $n_{1N50\%}$ [rpm] at 50% $T_{2N}$ and S1	4500				
Max. average drive speed $n_{1N100\%}$ [rpm] at 100% $T_{2N}$ and S1	4500				
Max. backlash $J_s$ [arcmin]	12				
Torsional rigidity $C_{121}$ [Nm/arcmin]	12	11.4	11.8	7.5	5.1
Max. radial force $F_{rmax}$ [N] for 30,000 h	500				
Max. radial force $F_{rmax}$ [N] for 20,000 h	550				
Max. axial force $F_{amax}$ [N] for 30,000 h	1200				
Max. axial force $F_{amax}$ [N] for 20,000 h	1200				
Operating noise $L_{PA}$ [dB(A)]	58				
Efficiency at full load $\eta$ [%]	94				
Weight $m$ [kg]	1.02	1.03	1.04	1.03	1.09
Moment of inertia $J_1$ [kgcm <sup>2</sup> ]	0.015	0.006		0.005	0.003

## 4.4.7.12 8D1B23.eH - 4,100 rpm (8GM40, gearbox size 060) - Technical data

## Gear ratio 005 to 020

Order number	8D1B23. eHgBDDk00-1	8D1B23. eHgBDFk00-1	8D1B23. eHgBDHk00-1	8D1B23. eHgBDJk00-1	8D1B23. eHgBDLk00-1
<b>General information</b>					
Certifications					
CE	Yes				
<b>Motor</b>					
Nominal speed $n_N$ [rpm]	4100				
Number of pole pairs	5				
Nominal torque $M_N$ [Nm]	0.792				
Nominal power $P_N$ [W]	340				
Nominal current $I_N$ [A]	7.2				
Stall torque $M_0$ [Nm]	0.88				
Stall current $I_0$ [A]	8				
Maximum torque $M_{max}$ [Nm]	1.56				
Maximum current $I_{max}$ [A]	15.7				
Maximum speed $n_{max}$ [rpm]	6600				
Torque constant $K_T$ [Nm/A]	0.11				
Voltage constant $K_E$ [V/1000 rpm]	6.6				
Stator resistance $R_{zph}$ [ $\Omega$ ]	0.2				
Stator inductance $L_{zph}$ [mH]	0.24				
Electrical time constant $t_{el}$ [ms]	1.2				
Thermal time constant $t_{therm}$ [min]	38				
Moment of inertia $J$ [kgcm <sup>2</sup> ]	0.41				
Weight without brake $m$ [kg]	1.62				
Max. permissible output torque $M_{KN}$ [Nm]	1.69	2.7	3.37	5.06	6.74
Max. permissible peak torque $M_{Kmax}$ [Nm]	6.7	10.72	13.4	20.1	26.8
<b>Holding brake</b>					
Holding torque of brake $M_{Br}$ [Nm]	2.2				
Mass of brake [kg]	0.28				
Moment of inertia of brake $J_{Br}$ [kgcm <sup>2</sup> ]	0.12				
<b>Gearbox</b>					
Number of gear stages	1			2	
Gear ratio $i$	5	8	10	15	20
Nominal output torque $T_{2N}$ [Nm]	16	15		44	
Max. output torque $T_{2max}$ [Nm]	25	24		70	
Emergency switch-off torque $T_{2stop}$ [Nm]	32	30		88	
Max. average drive speed $n_{1N50\%}$ [rpm] at 50% $T_{2N}$ and S1	4500				
Max. average drive speed $n_{1N100\%}$ [rpm] at 100% $T_{2N}$ and S1	4500				
Max. backlash $J_s$ [arcmin]	10			12	
Torsional rigidity $C_{21}$ [Nm/arcmin]	2.6	2.3	2.2	2.4	2.5
Max. radial force $F_{rmax}$ [N] for 30,000 h	340				
Max. radial force $F_{rmax}$ [N] for 20,000 h	400				
Max. axial force $F_{amax}$ [N] for 30,000 h	450				
Max. axial force $F_{amax}$ [N] for 20,000 h	500				
Operating noise $L_{PA}$ [dB(A)]	58				
Efficiency at full load $\eta$ [%]	96			94	
Weight $m$ [kg]	0.57		0.58	0.75	0.76
Moment of inertia $J_1$ [kgcm <sup>2</sup> ]	0.019	0.007	0.004	0.016	0.015

## Gear ratio 025 to 100

Order number	8D1B23. eHgBDMk00-1	8D1B23. eHgBDNk00-1	8D1B23. eHgBDQk00-1	8D1B23. eHgBDTk00-1	8D1B23. eHgBDWk00-1
<b>General information</b>					
Certifications					
CE	Yes				
<b>Motor</b>					
Nominal speed $n_N$ [rpm]	4100				
Number of pole pairs	5				
Nominal torque $M_n$ [Nm]	0.792				
Nominal power $P_N$ [W]	340				
Nominal current $I_N$ [A]	7.2				
Stall torque $M_0$ [Nm]	0.88				
Stall current $I_0$ [A]	8				
Maximum torque $M_{max}$ [Nm]	1.56				
Maximum current $I_{max}$ [A]	15.7				
Maximum speed $n_{max}$ [rpm]	6600				
Torque constant $K_T$ [Nm/A]	0.11				
Voltage constant $K_E$ [V/1000 rpm]	6.6				
Stator resistance $R_{2ph}$ [ $\Omega$ ]	0.2				
Stator inductance $L_{2ph}$ [mH]	0.24				
Electrical time constant $t_{el}$ [ms]	1.2				
Thermal time constant $t_{therm}$ [min]	38				
Moment of inertia $J$ [kgcm <sup>2</sup> ]	0.41				
Weight without brake $m$ [kg]	1.62				
Max. permissible output torque $M_{KN}$ [Nm]	8.43	10.78	13.48	21.57	33.7
Max. permissible peak torque $M_{Kmax}$ [Nm]	33.5	42.88	53.6	85.76	134
<b>Holding brake</b>					
Holding torque of brake $M_{Br}$ [Nm]	2.2				
Mass of brake [kg]	0.28				
Moment of inertia of brake $J_{Br}$ [kgcm <sup>2</sup> ]	0.12				
<b>Gearbox</b>					
Number of gear stages	2				
Gear ratio $i$	25	32	40	64	100
Nominal output torque $T_{2N}$ [Nm]	40	44	40	18	15
Max. output torque $T_{2max}$ [Nm]	64	70	64	30	24
Emergency switch-off torque $T_{2stop}$ [Nm]	80	88	80	36	30
Max. average drive speed $n_{1N50\%}$ [rpm] at 50% $T_{2N}$ and S1	4500				
Max. average drive speed $n_{1N100\%}$ [rpm] at 100% $T_{2N}$ and S1	4500				
Max. backlash $J_s$ [arcmin]	12				
Torsional rigidity $C_{t21}$ [Nm/arcmin]	2.6	2.5		2.3	2
Max. radial force $F_{rmax}$ [N] for 30,000 h	340				
Max. radial force $F_{rmax}$ [N] for 20,000 h	400				
Max. axial force $F_{amax}$ [N] for 30,000 h	450				
Max. axial force $F_{amax}$ [N] for 20,000 h	500				
Operating noise $L_{PA}$ [dB(A)]	58				
Efficiency at full load $\eta$ [%]	94				
Weight $m$ [kg]	0.77		0.78		0.96
Moment of inertia $J_1$ [kgcm <sup>2</sup> ]	0.014	0.005		0.003	

## 4.4.7.13 8D1B23.eH - 4,100 rpm (8GM45, gearbox size 067) - Technical data

## Gear ratio 005 to 020

Order number	8D1B23. eHgCFDk00-1	8D1B23. eHgCFFk00-1	8D1B23. eHgCFHk00-1	8D1B23. eHgCFJk00-1	8D1B23. eHgCFLk00-1
<b>General information</b>					
Certifications					
CE	Yes				
<b>Motor</b>					
Nominal speed $n_N$ [rpm]	4100				
Number of pole pairs	5				
Nominal torque $M_N$ [Nm]	0.792				
Nominal power $P_N$ [W]	340				
Nominal current $I_N$ [A]	7.2				
Stall torque $M_0$ [Nm]	0.88				
Stall current $I_0$ [A]	8				
Maximum torque $M_{max}$ [Nm]	1.56				
Maximum current $I_{max}$ [A]	15.7				
Maximum speed $n_{max}$ [rpm]	6600				
Torque constant $K_T$ [Nm/A]	0.11				
Voltage constant $K_E$ [V/1000 rpm]	6.6				
Stator resistance $R_{zph}$ [ $\Omega$ ]	0.2				
Stator inductance $L_{zph}$ [mH]	0.24				
Electrical time constant $t_{el}$ [ms]	1.2				
Thermal time constant $t_{therm}$ [min]	38				
Moment of inertia $J$ [kgcm <sup>2</sup> ]	0.41				
Weight without brake $m$ [kg]	1.62				
Max. permissible output torque $M_{KN}$ [Nm]	1.69	2.7	3.37	5.06	6.74
Max. permissible peak torque $M_{Kmax}$ [Nm]	6.7	10.72	13.4	20.1	26.8
<b>Holding brake</b>					
Holding torque of brake $M_{Br}$ [Nm]	2.2				
Mass of brake [kg]	0.28				
Moment of inertia of brake $J_{Br}$ [kgcm <sup>2</sup> ]	0.12				
<b>Gearbox</b>					
Number of gear stages	1			2	
Gear ratio $i$	5	8	10	15	20
Nominal output torque $T_{2N}$ [Nm]	16	15		44	
Max. output torque $T_{2max}$ [Nm]	25	24		70	
Emergency switch-off torque $T_{2stop}$ [Nm]	32	30		88	
Max. average drive speed $n_{1N50\%}$ [rpm] at 50% $T_{2N}$ and S1	4500				
Max. average drive speed $n_{1N100\%}$ [rpm] at 100% $T_{2N}$ and S1	4500				
Max. backlash $J_s$ [arcmin]	10			12	
Torsional rigidity $C_{21}$ [Nm/arcmin]	4.1	3.4	3.1	3.6	3.8
Max. radial force $F_{rmax}$ [N] for 30,000 h	700				
Max. radial force $F_{rmax}$ [N] for 20,000 h	900				
Max. axial force $F_{amax}$ [N] for 30,000 h	800				
Max. axial force $F_{amax}$ [N] for 20,000 h	1000				
Operating noise $L_{PA}$ [dB(A)]	58				
Efficiency at full load $\eta$ [%]	96			94	
Weight $m$ [kg]	0.78		0.79	0.96	0.97
Moment of inertia $J_1$ [kgcm <sup>2</sup> ]	0.024	0.008	0.005	0.016	0.015

## Gear ratio 025 to 100

Order number	8D1B23. eHgCFMk00-1	8D1B23. eHgCFNk00-1	8D1B23. eHgCFQk00-1	8D1B23. eHgCFTk00-1	8D1B23. eHgCFWk00-1
<b>General information</b>					
Certifications					
CE	Yes				
<b>Motor</b>					
Nominal speed $n_N$ [rpm]	4100				
Number of pole pairs	5				
Nominal torque $M_n$ [Nm]	0.792				
Nominal power $P_N$ [W]	340				
Nominal current $I_N$ [A]	7.2				
Stall torque $M_0$ [Nm]	0.88				
Stall current $I_0$ [A]	8				
Maximum torque $M_{max}$ [Nm]	1.56				
Maximum current $I_{max}$ [A]	15.7				
Maximum speed $n_{max}$ [rpm]	6600				
Torque constant $K_T$ [Nm/A]	0.11				
Voltage constant $K_E$ [V/1000 rpm]	6.6				
Stator resistance $R_{2ph}$ [ $\Omega$ ]	0.2				
Stator inductance $L_{2ph}$ [mH]	0.24				
Electrical time constant $t_{el}$ [ms]	1.2				
Thermal time constant $t_{therm}$ [min]	38				
Moment of inertia $J$ [kgcm <sup>2</sup> ]	0.41				
Weight without brake $m$ [kg]	1.62				
Max. permissible output torque $M_{KN}$ [Nm]	8.43	10.78	13.48	21.57	33.7
Max. permissible peak torque $M_{Kmax}$ [Nm]	33.5	42.88	53.6	85.76	134
<b>Holding brake</b>					
Holding torque of brake $M_{Br}$ [Nm]	2.2				
Mass of brake [kg]	0.28				
Moment of inertia of brake $J_{Br}$ [kgcm <sup>2</sup> ]	0.12				
<b>Gearbox</b>					
Number of gear stages	2				
Gear ratio $i$	25	32	40	64	100
Nominal output torque $T_{2N}$ [Nm]	40	44	40	18	15
Max. output torque $T_{2max}$ [Nm]	64	70	64	30	24
Emergency switch-off torque $T_{2stop}$ [Nm]	80	88	80	36	30
Max. average drive speed $n_{1N50\%}$ [rpm] at 50% $T_{2N}$ and S1	4500				
Max. average drive speed $n_{1N100\%}$ [rpm] at 100% $T_{2N}$ and S1	4500				
Max. backlash $J_s$ [arcmin]	12				
Torsional rigidity $C_{t21}$ [Nm/arcmin]	3.9	3.8	3.9	3.3	2.7
Max. radial force $F_{rmax}$ [N] for 30,000 h	700				
Max. radial force $F_{rmax}$ [N] for 20,000 h	900				
Max. axial force $F_{amax}$ [N] for 30,000 h	800				
Max. axial force $F_{amax}$ [N] for 20,000 h	1000				
Operating noise $L_{PA}$ [dB(A)]	58				
Efficiency at full load $\eta$ [%]	94				
Weight $m$ [kg]	0.98		0.99		1.16
Moment of inertia $J_1$ [kgcm <sup>2</sup> ]	0.014	0.006	0.005		0.003

## 4.4.7.14 8D1B23.eH - 4,100 rpm (8GM50, gearbox size 070) - Technical data

## Gear ratio 005 to 020

Order number	8D1B23. eHgDGDk00-1	8D1B23. eHgDGFk00-1	8D1B23. eHgDGHk00-1	8D1B23. eHgDGJk00-1	8D1B23. eHgDGLk00-1
<b>General information</b>					
Certifications					
CE	Yes				
<b>Motor</b>					
Nominal speed $n_N$ [rpm]	4100				
Number of pole pairs	5				
Nominal torque $M_N$ [Nm]	0.792				
Nominal power $P_N$ [W]	340				
Nominal current $I_N$ [A]	7.2				
Stall torque $M_0$ [Nm]	0.88				
Stall current $I_0$ [A]	8				
Maximum torque $M_{max}$ [Nm]	1.56				
Maximum current $I_{max}$ [A]	15.7				
Maximum speed $n_{max}$ [rpm]	6600				
Torque constant $K_T$ [Nm/A]	0.11				
Voltage constant $K_E$ [V/1000 rpm]	6.6				
Stator resistance $R_{zph}$ [ $\Omega$ ]	0.2				
Stator inductance $L_{zph}$ [mH]	0.24				
Electrical time constant $t_{el}$ [ms]	1.2				
Thermal time constant $t_{therm}$ [min]	38				
Moment of inertia $J$ [kgcm <sup>2</sup> ]	0.41				
Weight without brake $m$ [kg]	1.62				
Max. permissible output torque $M_{KN}$ [Nm]	1.69	2.7	3.37	5.06	6.74
Max. permissible peak torque $M_{Kmax}$ [Nm]	6.7	10.72	13.4	20.1	26.8
<b>Holding brake</b>					
Holding torque of brake $M_{Br}$ [Nm]	2.2				
Mass of brake [kg]	0.28				
Moment of inertia of brake $J_{Br}$ [kgcm <sup>2</sup> ]	0.12				
<b>Gearbox</b>					
Number of gear stages	1			2	
Gear ratio $i$	5	8	10	15	20
Nominal output torque $T_{2N}$ [Nm]	16	15		33	
Max. output torque $T_{2max}$ [Nm]	26	24		53	
Emergency switch-off torque $T_{2stop}$ [Nm]	32	30		66	
Max. average drive speed $n_{1N50\%}$ [rpm] at 50% $T_{2N}$ and S1	4500				
Max. average drive speed $n_{1N100\%}$ [rpm] at 100% $T_{2N}$ and S1	4500				
Max. backlash $J_s$ [arcmin]	10			12	
Torsional rigidity $C_{21}$ [Nm/arcmin]	5.7	4.4	3.9	4.9	5.2
Max. radial force $F_{rmax}$ [N] for 30,000 h	900				
Max. radial force $F_{rmax}$ [N] for 20,000 h	1050				
Max. axial force $F_{amax}$ [N] for 30,000 h	1000				
Max. axial force $F_{amax}$ [N] for 20,000 h	1350				
Operating noise $L_{PA}$ [dB(A)]	58				
Efficiency at full load $\eta$ [%]	96			94	
Weight $m$ [kg]	1.1	1.12	1.13	1.39	1.4
Moment of inertia $J_1$ [kgcm <sup>2</sup> ]	0.035	0.013	0.008	0.018	0.016

## Gear ratio 025 to 100

Order number	8D1B23. eHgDGMk00-1	8D1B23. eHgDGNk00-1	8D1B23. eHgDGQk00-1	8D1B23. eHgDGTk00-1	8D1B23. eHgDGWk00-1
<b>General information</b>					
Certifications					
CE	Yes				
<b>Motor</b>					
Nominal speed $n_N$ [rpm]	4100				
Number of pole pairs	5				
Nominal torque $M_n$ [Nm]	0.792				
Nominal power $P_N$ [W]	340				
Nominal current $I_N$ [A]	7.2				
Stall torque $M_0$ [Nm]	0.88				
Stall current $I_0$ [A]	8				
Maximum torque $M_{max}$ [Nm]	1.56				
Maximum current $I_{max}$ [A]	15.7				
Maximum speed $n_{max}$ [rpm]	6600				
Torque constant $K_T$ [Nm/A]	0.11				
Voltage constant $K_E$ [V/1000 rpm]	6.6				
Stator resistance $R_{2ph}$ [ $\Omega$ ]	0.2				
Stator inductance $L_{2ph}$ [mH]	0.24				
Electrical time constant $t_{el}$ [ms]	1.2				
Thermal time constant $t_{therm}$ [min]	38				
Moment of inertia $J$ [kgcm <sup>2</sup> ]	0.41				
Weight without brake $m$ [kg]	1.62				
Max. permissible output torque $M_{KN}$ [Nm]	8.43	10.78	13.48	21.57	33.7
Max. permissible peak torque $M_{Kmax}$ [Nm]	33.5	42.88	53.6	85.76	134
<b>Holding brake</b>					
Holding torque of brake $M_{Br}$ [Nm]	2.2				
Mass of brake [kg]	0.28				
Moment of inertia of brake $J_{Br}$ [kgcm <sup>2</sup> ]	0.12				
<b>Gearbox</b>					
Number of gear stages	2				
Gear ratio $i$	25	32	40	64	100
Nominal output torque $T_{2N}$ [Nm]	30	33	30	18	15
Max. output torque $T_{2max}$ [Nm]	48	53	48	29	24
Emergency switch-off torque $T_{2stop}$ [Nm]	60	66	60	36	30
Max. average drive speed $n_{1N50\%}$ [rpm] at 50% $T_{2N}$ and S1	4500				
Max. average drive speed $n_{1N100\%}$ [rpm] at 100% $T_{2N}$ and S1	4500				
Max. backlash $J_s$ [arcmin]	12				
Torsional rigidity $C_{t21}$ [Nm/arcmin]	5.3	5.1	5.2	4.2	3.3
Max. radial force $F_{rmax}$ [N] for 30,000 h	900				
Max. radial force $F_{rmax}$ [N] for 20,000 h	1050				
Max. axial force $F_{amax}$ [N] for 30,000 h	1000				
Max. axial force $F_{amax}$ [N] for 20,000 h	1350				
Operating noise $L_{PA}$ [dB(A)]	58				
Efficiency at full load $\eta$ [%]	94				
Weight $m$ [kg]	1.4	1.41	1.42	1.42	1.57
Moment of inertia $J_1$ [kgcm <sup>2</sup> ]	0.015	0.006	0.005	0.005	0.003

## 4.4.7.15 8D1B23.eH - 4,100 rpm (8GM55, gearbox size 060) - Technical data

## Gear ratio 005 to 020

Order number	8D1B23. eHgEDDk00-1	8D1B23. eHgEDFk00-1	8D1B23. eHgEDHk00-1	8D1B23. eHgEDJk00-1	8D1B23. eHgEDLk00-1
<b>General information</b>					
Certifications					
CE	Yes				
<b>Motor</b>					
Nominal speed $n_N$ [rpm]	4100				
Number of pole pairs	5				
Nominal torque $M_N$ [Nm]	0.792				
Nominal power $P_N$ [W]	340				
Nominal current $I_N$ [A]	7.2				
Stall torque $M_0$ [Nm]	0.88				
Stall current $I_0$ [A]	8				
Maximum torque $M_{max}$ [Nm]	1.56				
Maximum current $I_{max}$ [A]	15.7				
Maximum speed $n_{max}$ [rpm]	6600				
Torque constant $K_T$ [Nm/A]	0.11				
Voltage constant $K_E$ [V/1000 rpm]	6.6				
Stator resistance $R_{zph}$ [ $\Omega$ ]	0.2				
Stator inductance $L_{zph}$ [mH]	0.24				
Electrical time constant $t_{el}$ [ms]	1.2				
Thermal time constant $t_{therm}$ [min]	38				
Moment of inertia $J$ [kgcm <sup>2</sup> ]	0.41				
Weight without brake $m$ [kg]	1.62				
Max. permissible output torque $M_{KN}$ [Nm]	1.93	2.7	3.37	5.06	6.74
Max. permissible peak torque $M_{Kmax}$ [Nm]	6.7	10.72	13.4	20.1	26.8
<b>Holding brake</b>					
Holding torque of brake $M_{Br}$ [Nm]	2.2				
Mass of brake [kg]	0.28				
Moment of inertia of brake $J_{Br}$ [kgcm <sup>2</sup> ]	0.12				
<b>Gearbox</b>					
Number of gear stages	1			2	
Gear ratio $i$	5	8	10	15	20
Nominal output torque $T_{2N}$ [Nm]	16	15		44	
Max. output torque $T_{2max}$ [Nm]	25	24		70	
Emergency switch-off torque $T_{2stop}$ [Nm]	32	30		88	
Max. average drive speed $n_{1N50\%}$ [rpm] at 50% $T_{2N}$ and S1	4200	4500			
Max. average drive speed $n_{1N100\%}$ [rpm] at 100% $T_{2N}$ and S1	3400	4500			
Max. backlash $J_s$ [arcmin]	10			12	
Torsional rigidity $C_{21}$ [Nm/arcmin]	4.5	3.7	3.3	3.9	4.2
Max. radial force $F_{rmax}$ [N] for 30,000 h	3200				
Max. radial force $F_{rmax}$ [N] for 20,000 h	3200				
Max. axial force $F_{amax}$ [N] for 30,000 h	3900				
Max. axial force $F_{amax}$ [N] for 20,000 h	4400				
Operating noise $L_{PA}$ [dB(A)]	58				
Efficiency at full load $\eta$ [%]	96			94	
Weight $m$ [kg]	0				
Moment of inertia $J_1$ [kgcm <sup>2</sup> ]	0.037	0.014	0.008	0.021	0.019

**Gear ratio 025 to 100**

Order number	8D1B23. eHgEDMk00-1	8D1B23. eHgEDNk00-1	8D1B23. eHgEDQk00-1	8D1B23. eHgEDTk00-1	8D1B23. eHgEDWk00-1
<b>General information</b>					
Certifications					
CE	Yes				
<b>Motor</b>					
Nominal speed $n_N$ [rpm]	4100				
Number of pole pairs	5				
Nominal torque $M_n$ [Nm]	0.792				
Nominal power $P_N$ [W]	340				
Nominal current $I_N$ [A]	7.2				
Stall torque $M_0$ [Nm]	0.88				
Stall current $I_0$ [A]	8				
Maximum torque $M_{max}$ [Nm]	1.56				
Maximum current $I_{max}$ [A]	15.7				
Maximum speed $n_{max}$ [rpm]	6600				
Torque constant $K_T$ [Nm/A]	0.11				
Voltage constant $K_E$ [V/1000 rpm]	6.6				
Stator resistance $R_{2ph}$ [ $\Omega$ ]	0.2				
Stator inductance $L_{2ph}$ [mH]	0.24				
Electrical time constant $t_{el}$ [ms]	1.2				
Thermal time constant $t_{therm}$ [min]	38				
Moment of inertia $J$ [kgcm <sup>2</sup> ]	0.41				
Weight without brake $m$ [kg]	1.62				
Max. permissible output torque $M_{KN}$ [Nm]	8.43	10.78	13.48	21.57	33.7
Max. permissible peak torque $M_{Kmax}$ [Nm]	33.5	42.88	53.6	85.76	134
<b>Holding brake</b>					
Holding torque of brake $M_{Br}$ [Nm]	2.2				
Mass of brake [kg]	0.28				
Moment of inertia of brake $J_{Br}$ [kgcm <sup>2</sup> ]	0.12				
<b>Gearbox</b>					
Number of gear stages	2				
Gear ratio $i$	25	32	40	64	100
Nominal output torque $T_{2N}$ [Nm]	40	44	40	18	15
Max. output torque $T_{2max}$ [Nm]	64	70	64	30	24
Emergency switch-off torque $T_{2stop}$ [Nm]	80	88	80	36	30
Max. average drive speed $n_{1N50\%}$ [rpm] at 50% $T_{2N}$ and S1	4500				
Max. average drive speed $n_{1N100\%}$ [rpm] at 100% $T_{2N}$ and S1	4500				
Max. backlash $J_1$ [arcmin]	12				
Torsional rigidity $C_{121}$ [Nm/arcmin]	4.2	4.1	4.2	3.5	2.9
Max. radial force $F_{rmax}$ [N] for 30,000 h	3200				
Max. radial force $F_{rmax}$ [N] for 20,000 h	3200				
Max. axial force $F_{amax}$ [N] for 30,000 h	3900				
Max. axial force $F_{amax}$ [N] for 20,000 h	4400				
Operating noise $L_{PA}$ [dB(A)]	58				
Efficiency at full load $\eta$ [%]	94				
Weight $m$ [kg]	0				
Moment of inertia $J_1$ [kgcm <sup>2</sup> ]	0.018	0.007		0.006	0.004

## 4.4.7.16 8D1B23.eH - 4,100 rpm (8GG40, gearbox size 064) - Technical data

## Gear ratio 005 to 020

Order number	8D1B23. eHgHEDk00-1	8D1B23. eHgHEFk00-1	8D1B23. eHgHEHk00-1	8D1B23. eHgHEJk00-1	8D1B23. eHgHELk00-1
<b>General information</b>					
Certifications					
CE	Yes				
<b>Motor</b>					
Nominal speed $n_N$ [rpm]	4100				
Number of pole pairs	5				
Nominal torque $M_N$ [Nm]	0.792				
Nominal power $P_N$ [W]	340				
Nominal current $I_N$ [A]	7.2				
Stall torque $M_0$ [Nm]	0.88				
Stall current $I_0$ [A]	8				
Maximum torque $M_{max}$ [Nm]	1.56				
Maximum current $I_{max}$ [A]	15.7				
Maximum speed $n_{max}$ [rpm]	6600				
Torque constant $K_T$ [Nm/A]	0.11				
Voltage constant $K_E$ [V/1000 rpm]	6.6				
Stator resistance $R_{zph}$ [ $\Omega$ ]	0.2				
Stator inductance $L_{zph}$ [mH]	0.24				
Electrical time constant $t_{el}$ [ms]	1.2				
Thermal time constant $t_{therm}$ [min]	38				
Moment of inertia $J$ [kgcm <sup>2</sup> ]	0.41				
Weight without brake $m$ [kg]	1.62				
Max. permissible output torque $M_{KN}$ [Nm]	1.8	2.7	3.37	5.06	6.74
Max. permissible peak torque $M_{Kmax}$ [Nm]	6.7	10.72	13.4	20.1	26.8
<b>Holding brake</b>					
Holding torque of brake $M_{Br}$ [Nm]	2.2				
Mass of brake [kg]	0.28				
Moment of inertia of brake $J_{Br}$ [kgcm <sup>2</sup> ]	0.12				
<b>Gearbox</b>					
Number of gear stages	1			2	
Gear ratio $i$	5	8	10	15	20
Nominal output torque $T_{2N}$ [Nm]	16	15		44	
Max. output torque $T_{2max}$ [Nm]	25	24		70	
Emergency switch-off torque $T_{2stop}$ [Nm]	32	30		88	
Max. average drive speed $n_{1N50\%}$ [rpm] at 50% $T_{2N}$ and S1	4500				
Max. average drive speed $n_{1N100\%}$ [rpm] at 100% $T_{2N}$ and S1	4000	4500			
Max. backlash $J_s$ [arcmin]	10			12	
Torsional rigidity $C_{21}$ [Nm/arcmin]	14.2	8.2	6.4	10.2	11.7
Max. radial force $F_{rmax}$ [N] for 30,000 h	500				
Max. radial force $F_{rmax}$ [N] for 20,000 h	550				
Max. axial force $F_{amax}$ [N] for 30,000 h	1200				
Max. axial force $F_{amax}$ [N] for 20,000 h	1200				
Operating noise $L_{PA}$ [dB(A)]	58				
Efficiency at full load $\eta$ [%]	96			94	
Weight $m$ [kg]	0.78		0.79	1	1.02
Moment of inertia $J_1$ [kgcm <sup>2</sup> ]	0.049	0.018	0.011	0.019	0.017

**Gear ratio 025 to 100**

Order number	8D1B23. eHgHEMk00-1	8D1B23. eHgHENk00-1	8D1B23. eHgHEQk00-1	8D1B23. eHgHETk00-1	8D1B23. eHgHEWk00-1
<b>General information</b>					
Certifications					
CE	Yes				
<b>Motor</b>					
Nominal speed $n_N$ [rpm]	4100				
Number of pole pairs	5				
Nominal torque $M_n$ [Nm]	0.792				
Nominal power $P_N$ [W]	340				
Nominal current $I_N$ [A]	7.2				
Stall torque $M_0$ [Nm]	0.88				
Stall current $I_0$ [A]	8				
Maximum torque $M_{max}$ [Nm]	1.56				
Maximum current $I_{max}$ [A]	15.7				
Maximum speed $n_{max}$ [rpm]	6600				
Torque constant $K_T$ [Nm/A]	0.11				
Voltage constant $K_E$ [V/1000 rpm]	6.6				
Stator resistance $R_{2ph}$ [ $\Omega$ ]	0.2				
Stator inductance $L_{2ph}$ [mH]	0.24				
Electrical time constant $t_{el}$ [ms]	1.2				
Thermal time constant $t_{therm}$ [min]	38				
Moment of inertia $J$ [kgcm <sup>2</sup> ]	0.41				
Weight without brake $m$ [kg]	1.62				
Max. permissible output torque $M_{KN}$ [Nm]	8.43	10.78	13.48	21.57	33.7
Max. permissible peak torque $M_{Kmax}$ [Nm]	33.5	42.88	53.6	85.76	134
<b>Holding brake</b>					
Holding torque of brake $M_{Br}$ [Nm]	2.2				
Mass of brake [kg]	0.28				
Moment of inertia of brake $J_{Br}$ [kgcm <sup>2</sup> ]	0.12				
<b>Gearbox</b>					
Number of gear stages	2				
Gear ratio $i$	25	32	40	64	100
Nominal output torque $T_{2N}$ [Nm]	40	44	40	18	15
Max. output torque $T_{2max}$ [Nm]	64	70	64	30	24
Emergency switch-off torque $T_{2stop}$ [Nm]	80	88	80	36	30
Max. average drive speed $n_{1N50\%}$ [rpm] at 50% $T_{2N}$ and S1	4500				
Max. average drive speed $n_{1N100\%}$ [rpm] at 100% $T_{2N}$ and S1	4500				
Max. backlash $J_s$ [arcmin]	12				
Torsional rigidity $C_{t21}$ [Nm/arcmin]	12	11.4	11.8	7.5	5.1
Max. radial force $F_{rmax}$ [N] for 30,000 h	500				
Max. radial force $F_{rmax}$ [N] for 20,000 h	550				
Max. axial force $F_{amax}$ [N] for 30,000 h	1200				
Max. axial force $F_{amax}$ [N] for 20,000 h	1200				
Operating noise $L_{PA}$ [dB(A)]	58				
Efficiency at full load $\eta$ [%]	94				
Weight $m$ [kg]	1.02	1.03	1.04	1.03	1.09
Moment of inertia $J_1$ [kgcm <sup>2</sup> ]	0.015	0.006		0.005	0.003

#### 4.4.8 8D1C2 - Technical data

ACOPOSmotor Compact 8D1C modules consist of an **8D1A module** with flange-mounted **gearbox**. Due to the variety of combinations, the technical data for the motor and gearbox is listed separately.

##### Motor data (without gearbox)

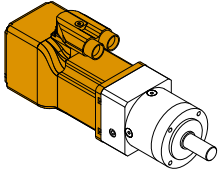

Product ID	8D1C22	8D1C23	8D1C23
<b>General information</b>			
Certifications			
CE		Yes	
UL		cURus E225616	
		Power conversion equipment	
<b>Motor</b>			
Nominal speed $n_N$ [rpm]	4500	2000	4100
Number of pole pairs		5	
Nominal torque $M_N$ [Nm]	0.536	1.047	0.792
Nominal power $P_N$ [W]	253	219	340
Nominal current $I_N$ [A]	5.36	4.76	7.2
Stall torque $M_0$ [Nm]	0.659	1.118	0.88
Stall current $I_0$ [A]	6.59	5.08	8
Maximum torque $M_{max}$ [Nm]	1.34	3.01	1.56
Maximum current $I_{max}$ [A]		15.7	
Maximum speed $n_{max}$ [rpm]		6600	
Torque constant $K_T$ [Nm/A]	0.1	0.22	0.11
Voltage constant $K_E$ [V/1000 rpm]	5.97	13.41	6.6
Stator resistance $R_{2ph}$ [ $\Omega$ ]	0.4	0.76	0.2
Stator inductance $L_{2ph}$ [mH]	0.37	0.93	0.24
Electrical time constant $t_{el}$ [ms]	0.93		1.2
Thermal time constant $t_{therm}$ [min]	35		38
Moment of inertia $J$ [kgcm <sup>2</sup> ]	0.22		0.41
Weight without brake $m$ [kg]	1.26		1.62
<b>Holding brake</b>			
Holding torque of brake $M_{Br}$ [Nm]		2.2	
Mass of brake [kg]		0.28	
Moment of inertia of brake $J_{Br}$ [kgcm <sup>2</sup> ]		0.12	

Table 126: 8D1C22, 8D1C23, 8D1C23 - Technical data

##### Flange-mounted 8GP - Gearbox data

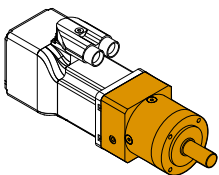

Gearbox	Technical data
8GP40, gearbox size 060	see "8GP40, gearbox size 060 - Technical data" on page 193
8GP40, gearbox size 080	see "8GP40, gearbox size 080 - Technical data" on page 194
8GP45, gearbox size 067	see "8GP45, gearbox size 067 - Technical data" on page 197
8GP45, gearbox size 089	see "8GP45, gearbox size 089 - Technical data" on page 198
8GP50, gearbox size 070	see "8GP50, gearbox size 070 - Technical data" on page 201
8GP50, gearbox size 090	see "8GP50, gearbox size 090 - Technical data" on page 202
8GP55, gearbox size 060	see "8GP55, gearbox size 060 - Technical data" on page 205
8GP55, gearbox size 080	see "8GP55, gearbox size 080 - Technical data" on page 206
8GP60, gearbox size 070	see "8GP60, gearbox size 070 - Technical data" on page 209
8GP70, gearbox size 070	see "8GP70, gearbox size 070 - Technical data" on page 212

### Flange-mounted 8GF - Gearbox data

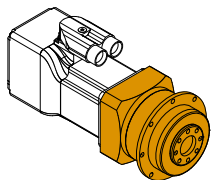

Gearbox	Technical data
8GF40, gearbox size 064	see "8GF40, gearbox size 064 - Technical data" on page 215
8GF60, gearbox size 064	see "8GF60, gearbox size 064 - Technical data" on page 216
8GF70, gearbox size 064	see "8GF70, gearbox size 064 - Technical data" on page 219

### Flange-mounted 8GA - Gearbox data

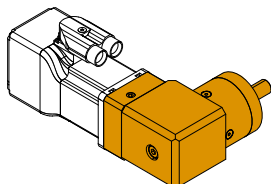

Gearbox	Technical data
8GA40, gearbox size 060	see "8GA40, gearbox size 060 - Technical data" on page 221
8GA40, gearbox size 080	see "8GA40, gearbox size 080 - Technical data" on page 224
8GA45, gearbox size 067	see "8GA45, gearbox size 067 - Technical data" on page 227
8GA45, gearbox size 089	see "8GA45, gearbox size 089 - Technical data" on page 230
8GA50, gearbox size 070	see "8GA50, gearbox size 070 - Technical data" on page 233
8GA50, gearbox size 090	see "8GA50, gearbox size 090 - Technical data" on page 236
8GA55, gearbox size 064	see "8GA55, gearbox size 064 - Technical data" on page 239
8GA60, gearbox size 070	see "8GA60, gearbox size 070 - Technical data" on page 242

## 4.4.8.1 8GP40, gearbox size 060 - Technical data

## Gear ratio 003 to 016

Order number	8GP40-060h-h003klmm	8GP40-060h-h004klmm	8GP40-060h-h007klmm	8GP40-060h-h009klmm	8GP40-060h-h012klmm	8GP40-060h-h016klmm
<b>Gearbox</b>						
Number of gear stages	1			2		
Gear ratio i	3	4	7	9	12	16
Nominal output torque $T_{2N}$ [Nm]	28	38	25	44		
Max. output torque $T_{2max}$ [Nm]	45	61	40	70		
Emergency switch-off torque $T_{2stop}$ [Nm]	66	88	80	88		
Idle torque [Nm] at 20°C and 3000 rpm	0.15	0.1				
Max. average drive speed $n_{1N50\%}$ [rpm] at 50% $T_{2N}$ and S1	4500					
Max. average drive speed $n_{1N100\%}$ [rpm] at 100% $T_{2N}$ and S1	4500					
Max. drive speed $n_{1max}$ [rpm]	13000					
Max. backlash $J_i$ [arcmin]	10			12		
Reduced backlash $J_i$ [arcmin] less than	0					
Torsional rigidity $C_{21}$ [Nm/arcmin]	2.3			2.5		
Tilting rigidity $C_{2K}$ [Nm/arcmin]	0					
Max. breakdown torque $M_{2Kmax}$ [Nm]	0					
Max. radial force $F_{rmax}$ [N] for 30,000 h	340					
Max. radial force $F_{rmax}$ [N] for 20,000 h	400					
Max. axial force $F_{amax}$ [N] for 30,000 h	450					
Max. axial force $F_{amax}$ [N] for 20,000 h	500					
Operating noise $L_{PA}$ [dB(A)]	58					
Efficiency at full load $\eta$ [%]	96			94		
Min. operating temperature $B_{Tempmin}$ [°C]	-25					
Max. operating temperature $B_{Tempmax}$ [°C]	90					
Mounting orientation	Any					
Degree of protection	IP54					
Weight m [kg]	0.9			1.1		
Moment of inertia $J_1$ [kgcm <sup>2</sup> ]	0.135	0.093	0.072	0.131	0.127	0.088

## 4.4.8.2 8GP40, gearbox size 080 - Technical data

## Gear ratio 003 to 010

Order number	8GP40-080h-h003klmm	8GP40-080h-h004klmm	8GP40-080h-h005klmm	8GP40-080h-h007klmm	8GP40-080h-h008klmm	8GP40-080h-h010klmm
<b>Gearbox</b>						
Number of gear stages	1					
Gear ratio i	3	4	5	7	8	10
Nominal output torque $T_{2N}$ [Nm]	85	115	110	65	50	38
Max. output torque $T_{2max}$ [Nm]	136	184	176	104	80	61
Emergency switch-off torque $T_{2stop}$ [Nm]	180	240	220	178	190	200
Idle torque [Nm] at 20°C and 3000 rpm	0.35		0.25	0.2		
Max. average drive speed $n_{1N50\%}$ [rpm] at 50% $T_{2N}$ and S1	4000	3900	4000			
Max. average drive speed $n_{1N100\%}$ [rpm] at 100% $T_{2N}$ and S1	2700	2500	3000	4000		
Max. drive speed $n_{1max}$ [rpm]	7000					
Max. backlash $J_1$ [arcmin]	7					
Reduced backlash $J_1$ [arcmin] less than	0					
Torsional rigidity $C_{21}$ [Nm/arcmin]	6					
Tilting rigidity $C_{2K}$ [Nm/arcmin]	0					
Max. breakdown torque $M_{2Kmax}$ [Nm]	0					
Max. radial force $F_{rmax}$ [N] for 30,000 h	650					
Max. radial force $F_{rmax}$ [N] for 20,000 h	750					
Max. axial force $F_{amax}$ [N] for 30,000 h	900					
Max. axial force $F_{amax}$ [N] for 20,000 h	1000					
Operating noise $L_{PA}$ [dB(A)]	60					
Efficiency at full load $\eta$ [%]	96					
Min. operating temperature $B_{Tempmin}$ [°C]	-25					
Max. operating temperature $B_{Tempmax}$ [°C]	90					
Mounting orientation	Any					
Degree of protection	IP54					
Weight m [kg]	2.1					
Moment of inertia $J_1$ [kgcm <sup>2</sup> ]	0.77	0.52	0.45	0.42	0.39	

## Gear ratio 009 to 025

Order number	8GP40-080h- h009klmm	8GP40-080h- h012klmm	8GP40-080h- h015klmm	8GP40-080h- h016klmm	8GP40-080h- h020klmm	8GP40-080h- h025klmm
<b>Gearbox</b>						
Number of gear stages	2					
Gear ratio i	9	12	15	16	20	25
Nominal output torque $T_{2N}$ [Nm]	130	120	110	120		110
Max. output torque $T_{2max}$ [Nm]	208	192	176	192		176
Emergency switch-off torque $T_{2stop}$ [Nm]	260	240	220	240		220
Idle torque [Nm] at 20°C and 3000 rpm	0.25				0.2	
Max. average drive speed $n_{1N50\%}$ [rpm] at 50% $T_{2N}$ and S1	4000					
Max. average drive speed $n_{1N100\%}$ [rpm] at 100% $T_{2N}$ and S1	3050	3750	4000			
Max. drive speed $n_{1max}$ [rpm]	7000					
Max. backlash $J_t$ [arcmin]	9					
Reduced backlash $J_t$ [arcmin] less than	0					
Torsional rigidity $C_{t21}$ [Nm/arcmin]	6.5					
Tilting rigidity $C_{2K}$ [Nm/arcmin]	0					
Max. breakdown torque $M_{2Kmax}$ [Nm]	0					
Max. radial force $F_{rmax}$ [N] for 30,000 h	650					
Max. radial force $F_{rmax}$ [N] for 20,000 h	750					
Max. axial force $F_{amax}$ [N] for 30,000 h	900					
Max. axial force $F_{amax}$ [N] for 20,000 h	1000					
Operating noise $L_{PA}$ [dB(A)]	60					
Efficiency at full load $\eta$ [%]	94					
Min. operating temperature $B_{Tempmin}$ [°C]	-25					
Max. operating temperature $B_{Tempmax}$ [°C]	90					
Mounting orientation	Any					
Degree of protection	IP54					
Weight m [kg]	2.6					
Moment of inertia $J_1$ [kgcm <sup>2</sup> ]	0.74	0.72	0.71	0.5	0.44	

## Gear ratio 032 to 080

Order number	8GP40-080h- h032klmm	8GP40-080h- h040klmm	8GP40-080h- h064klmm	8GP40-080h- h100klmm	8GP40-080h- h060klmm	8GP40-080h- h080klmm
<b>Gearbox</b>						
Number of gear stages	2				3	
Gear ratio i	32	40	64	100	60	80
Nominal output torque $T_{2N}$ [Nm]	120	110	50	38	110	120
Max. output torque $T_{2max}$ [Nm]	192	176	80	61	176	192
Emergency switch-off torque $T_{2stop}$ [Nm]	240	220	190	200	220	240
Idle torque [Nm] at 20°C and 3000 rpm	0.2	0.15			0.2	
Max. average drive speed $n_{1N50\%}$ [rpm] at 50% $T_{2N}$ and S1	4000					
Max. average drive speed $n_{1N100\%}$ [rpm] at 100% $T_{2N}$ and S1	4000					
Max. drive speed $n_{1max}$ [rpm]	7000					
Max. backlash $J_t$ [arcmin]	9				11	
Reduced backlash $J_t$ [arcmin] less than	0					
Torsional rigidity $C_{t21}$ [Nm/arcmin]	6.5				6.3	
Tilting rigidity $C_{2K}$ [Nm/arcmin]	0					
Max. breakdown torque $M_{2Kmax}$ [Nm]	0					
Max. radial force $F_{rmax}$ [N] for 30,000 h	650					
Max. radial force $F_{rmax}$ [N] for 20,000 h	750					
Max. axial force $F_{amax}$ [N] for 30,000 h	900					
Max. axial force $F_{amax}$ [N] for 20,000 h	1000					
Operating noise $L_{PA}$ [dB(A)]	60					
Efficiency at full load $\eta$ [%]	94				90	
Min. operating temperature $B_{Tempmin}$ [°C]	-25					
Max. operating temperature $B_{Tempmax}$ [°C]	90					
Mounting orientation	Any					
Degree of protection	IP54					
Weight m [kg]	2.6				3.1	
Moment of inertia $J_1$ [kgcm <sup>2</sup> ]	0.39				0.51	0.5

## 4.4.8.3 8GP45, gearbox size 067 - Technical data

## Gear ratio 003 to 016

Order number	8GP45-067h- h003klmm	8GP45-067h- h004klmm	8GP45-067h- h007klmm	8GP45-067h- h009klmm	8GP45-067h- h012klmm	8GP45-067h- h016klmm
<b>Gearbox</b>						
Number of gear stages	1			2		
Gear ratio i	3	4	7	9	12	16
Nominal output torque $T_{2N}$ [Nm]	28	38	25	44		
Max. output torque $T_{2max}$ [Nm]	45	61	40	70		
Emergency switch-off torque $T_{2stop}$ [Nm]	66	88	80	88		
Idle torque [Nm] at 20°C and 3000 rpm	0.2	0.15	0.1	0.15	0.1	
Max. average drive speed $n_{1N50\%}$ [rpm] at 50% $T_{2N}$ and S1	4500					
Max. average drive speed $n_{1N100\%}$ [rpm] at 100% $T_{2N}$ and S1	4200	4300	4500			
Max. drive speed $n_{1max}$ [rpm]	13000					
Max. backlash $J_i$ [arcmin]	10			12		
Reduced backlash $J_i$ [arcmin] less than	0					
Torsional rigidity $C_{21}$ [Nm/arcmin]	2.3			2.5		
Tilting rigidity $C_{2K}$ [Nm/arcmin]	0					
Max. breakdown torque $M_{2Kmax}$ [Nm]	0					
Max. radial force $F_{rmax}$ [N] for 30,000 h	700					
Max. radial force $F_{rmax}$ [N] for 20,000 h	900					
Max. axial force $F_{amax}$ [N] for 30,000 h	800					
Max. axial force $F_{amax}$ [N] for 20,000 h	1000					
Operating noise $L_{PA}$ [dB(A)]	58					
Efficiency at full load $\eta$ [%]	96			94		
Min. operating temperature $B_{Tempmin}$ [°C]	-25					
Max. operating temperature $B_{Tempmax}$ [°C]	90					
Mounting orientation	Any					
Degree of protection	IP54					
Weight m [kg]	1.1			1.3		
Moment of inertia $J_1$ [kgcm <sup>2</sup> ]	0.135	0.093	0.072	0.131	0.127	0.088

## 4.4.8.4 8GP45, gearbox size 089 - Technical data

## Gear ratio 003 to 010

Order number	8GP45-089h-h003klmm	8GP45-089h-h004klmm	8GP45-089h-h005klmm	8GP45-089h-h007klmm	8GP45-089h-h008klmm	8GP45-089h-h010klmm
<b>Gearbox</b>						
Number of gear stages	1					
Gear ratio i	3	4	5	7	8	10
Nominal output torque $T_{2N}$ [Nm]	85	115	110	65	50	38
Max. output torque $T_{2max}$ [Nm]	136	184	176	104	80	61
Emergency switch-off torque $T_{2stop}$ [Nm]	180	240	220	178	190	200
Idle torque [Nm] at 20°C and 3000 rpm	0.55	0.5	0.4	0.3	0.25	
Max. average drive speed $n_{1N50\%}$ [rpm] at 50% $T_{2N}$ and S1	3400	3450	4000			
Max. average drive speed $n_{1N100\%}$ [rpm] at 100% $T_{2N}$ and S1	2400	2350	2800	4000		
Max. drive speed $n_{1max}$ [rpm]	7000					
Max. backlash $J_1$ [arcmin]	7					
Reduced backlash $J_1$ [arcmin] less than	0					
Torsional rigidity $C_{21}$ [Nm/arcmin]	6					
Tilting rigidity $C_{2K}$ [Nm/arcmin]	0					
Max. breakdown torque $M_{2Kmax}$ [Nm]	0					
Max. radial force $F_{rmax}$ [N] for 30,000 h	1700					
Max. radial force $F_{rmax}$ [N] for 20,000 h	2050					
Max. axial force $F_{amax}$ [N] for 30,000 h	2000					
Max. axial force $F_{amax}$ [N] for 20,000 h	2500					
Operating noise $L_{PA}$ [dB(A)]	60					
Efficiency at full load $\eta$ [%]	96					
Min. operating temperature $B_{Tempmin}$ [°C]	-25					
Max. operating temperature $B_{Tempmax}$ [°C]	90					
Mounting orientation	Any					
Degree of protection	IP54					
Weight m [kg]	3.2					
Moment of inertia $J_1$ [kgcm <sup>2</sup> ]	0.77	0.52	0.45	0.42	0.39	

## Gear ratio 009 to 025

Order number	8GP45-089h- h009klmm	8GP45-089h- h012klmm	8GP45-089h- h015klmm	8GP45-089h- h016klmm	8GP45-089h- h020klmm	8GP45-089h- h025klmm
<b>Gearbox</b>						
Number of gear stages	2					
Gear ratio i	9	12	15	16	20	25
Nominal output torque $T_{2N}$ [Nm]	130	120	110	120		110
Max. output torque $T_{2max}$ [Nm]	208	192	176	192		176
Emergency switch-off torque $T_{2stop}$ [Nm]	260	240	220	240		220
Idle torque [Nm] at 20°C and 3000 rpm	0.3	0.25		0.3	0.25	
Max. average drive speed $n_{1N50\%}$ [rpm] at 50% $T_{2N}$ and S1	4000					
Max. average drive speed $n_{1N100\%}$ [rpm] at 100% $T_{2N}$ and S1	2950	3650	4000			
Max. drive speed $n_{1max}$ [rpm]	7000					
Max. backlash $J_t$ [arcmin]	9					
Reduced backlash $J_t$ [arcmin] less than	0					
Torsional rigidity $C_{t21}$ [Nm/arcmin]	6.5					
Tilting rigidity $C_{zK}$ [Nm/arcmin]	0					
Max. breakdown torque $M_{2Kmax}$ [Nm]	0					
Max. radial force $F_{rmax}$ [N] for 30,000 h	1700					
Max. radial force $F_{rmax}$ [N] for 20,000 h	2050					
Max. axial force $F_{amax}$ [N] for 30,000 h	2000					
Max. axial force $F_{amax}$ [N] for 20,000 h	2500					
Operating noise $L_{pA}$ [dB(A)]	60					
Efficiency at full load $\eta$ [%]	94					
Min. operating temperature $B_{Tempmin}$ [°C]	-25					
Max. operating temperature $B_{Tempmax}$ [°C]	90					
Mounting orientation	Any					
Degree of protection	IP54					
Weight m [kg]	3.7					
Moment of inertia $J_1$ [kgcm <sup>2</sup> ]	0.74	0.72	0.71	0.5	0.44	

**Gear ratio 032 to 100**

Order number	8GP45-089h- h032klmm	8GP45-089h- h040klmm	8GP45-089h- h060klmm	8GP45-089h- h064klmm	8GP45-089h- h080klmm	8GP45-089h- h100klmm
<b>Gearbox</b>						
Number of gear stages	2		3	2	3	2
Gear ratio i	32	40	60	64	80	100
Nominal output torque $T_{2N}$ [Nm]	120	110		50	120	38
Max. output torque $T_{2max}$ [Nm]	192	176		80	192	61
Emergency switch-off torque $T_{2stop}$ [Nm]	240	220		190	240	200
Idle torque [Nm] at 20°C and 3000 rpm	0.2					0.15
Max. average drive speed $n_{1N50\%}$ [rpm] at 50% $T_{2N}$ and S1	4000					
Max. average drive speed $n_{1N100\%}$ [rpm] at 100% $T_{2N}$ and S1	4000					
Max. drive speed $n_{1max}$ [rpm]	7000					
Max. backlash $J_i$ [arcmin]	9	11		9	11	9
Reduced backlash $J_i$ [arcmin] less than	0					
Torsional rigidity $C_{t21}$ [Nm/arcmin]	6.5	6.3		6.5	6.3	6.5
Tilting rigidity $C_{2K}$ [Nm/arcmin]	0					
Max. breakdown torque $M_{2Kmax}$ [Nm]	0					
Max. radial force $F_{rmax}$ [N] for 30,000 h	1700					
Max. radial force $F_{rmax}$ [N] for 20,000 h	2050					
Max. axial force $F_{amax}$ [N] for 30,000 h	2000					
Max. axial force $F_{amax}$ [N] for 20,000 h	2500					
Operating noise $L_{PA}$ [dB(A)]	60					
Efficiency at full load $\eta$ [%]	94	90		94	90	94
Min. operating temperature $B_{Tempmin}$ [°C]	-25					
Max. operating temperature $B_{Tempmax}$ [°C]	90					
Mounting orientation	Any					
Degree of protection	IP54					
Weight m [kg]	3.7	4.2		3.7	4.2	3.7
Moment of inertia $J_1$ [kgcm <sup>2</sup> ]	0.39	0.51		0.39	0.5	0.39

## 4.4.8.5 8GP50, gearbox size 070 - Technical data

## Gear ratio 003 to 016

Order number	8GP50-070h- h003klmm	8GP50-070h- h004klmm	8GP50-070h- h007klmm	8GP50-070h- h009klmm	8GP50-070h- h012klmm	8GP50-070h- h016klmm
<b>Gearbox</b>						
Number of gear stages	1		-	2		
Gear ratio i	3	4	7	9	12	16
Nominal output torque $T_{2N}$ [Nm]	28	33	25.0	33		
Max. output torque $T_{2max}$ [Nm]	45	53	40.0	53		
Emergency switch-off torque $T_{2stop}$ [Nm]	66	88	80	88		
Idle torque [Nm] at 20°C and 3000 rpm	0.4	0.25	0.15		0.1	
Max. average drive speed $n_{1N50\%}$ [rpm] at 50% $T_{2N}$ and S1	4500					
Max. average drive speed $n_{1N100\%}$ [rpm] at 100% $T_{2N}$ and S1	3650	4100	4500			
Max. drive speed $n_{1max}$ [rpm]	13000					
Max. backlash $J_1$ [arcmin]	10			12		
Reduced backlash $J_1$ [arcmin] less than	0		0	0		
Torsional rigidity $C_{21}$ [Nm/arcmin]	2.3			2.5		
Tilting rigidity $C_{2K}$ [Nm/arcmin]	0		0.0	0		
Max. breakdown torque $M_{2Kmax}$ [Nm]	0		0.0	0		
Max. radial force $F_{rmax}$ [N] for 30,000 h	900					
Max. radial force $F_{rmax}$ [N] for 20,000 h	1050					
Max. axial force $F_{amax}$ [N] for 30,000 h	1000					
Max. axial force $F_{amax}$ [N] for 20,000 h	1350					
Operating noise $L_{PA}$ [dB(A)]	58					
Efficiency at full load $\eta$ [%]	96			94		
Min. operating temperature $B_{Tempmin}$ [°C]	-25					
Max. operating temperature $B_{Tempmax}$ [°C]	90					
Mounting orientation	Any		-	Any		
Degree of protection	IP54		-	IP54		
Weight m [kg]	1.5		1.50	1.8		
Moment of inertia $J_1$ [kgcm <sup>2</sup> ]	0.157	0.106	0.078	0.133	0.128	0.089

## 4.4.8.6 8GP50, gearbox size 090 - Technical data

## Gear ratio 003 to 010

Order number	8GP50-090h-h003klmm	8GP50-090h-h004klmm	8GP50-090h-h005klmm	8GP50-090h-h007klmm	8GP50-090h-h008klmm	8GP50-090h-h010klmm
<b>Gearbox</b>						
Number of gear stages	1					
Gear ratio i	3	4	5	7	8	10
Nominal output torque $T_{2N}$ [Nm]	85	90	82	65	50	38
Max. output torque $T_{2max}$ [Nm]	136	144	131	104	80	61
Emergency switch-off torque $T_{2stop}$ [Nm]	180	240	220	178	190	200
Idle torque [Nm] at 20°C and 3000 rpm	0.75	0.55	0.45	0.3		0.25
Max. average drive speed $n_{1N50\%}$ [rpm] at 50% $T_{2N}$ and S1	3250	3750	4000			
Max. average drive speed $n_{1N100\%}$ [rpm] at 100% $T_{2N}$ and S1	2300	2650	3200	4000		
Max. drive speed $n_{1max}$ [rpm]	7000			0	7000	
Max. backlash $J_i$ [arcmin]	7					
Reduced backlash $J_i$ [arcmin] less than	0					
Torsional rigidity $C_{21}$ [Nm/arcmin]	6					
Tilting rigidity $C_{2K}$ [Nm/arcmin]	0					
Max. breakdown torque $M_{2Kmax}$ [Nm]	0					
Max. radial force $F_{rmax}$ [N] for 30,000 h	1700					
Max. radial force $F_{rmax}$ [N] for 20,000 h	1900					
Max. axial force $F_{amax}$ [N] for 30,000 h	1500					
Max. axial force $F_{amax}$ [N] for 20,000 h	2000					
Operating noise $L_{PA}$ [dB(A)]	60					
Efficiency at full load $\eta$ [%]	96					
Min. operating temperature $B_{Tempmin}$ [°C]	-25					
Max. operating temperature $B_{Tempmax}$ [°C]	90					
Mounting orientation	Any					
Degree of protection	IP54					
Weight m [kg]	3					
Moment of inertia $J_1$ [kgcm <sup>2</sup> ]	0.82	0.57	0.48	0.45	0.4	

## Gear ratio 009 to 025

Order number	8GP50-090h- h009klmm	8GP50-090h- h012klmm	8GP50-090h- h015klmm	8GP50-090h- h016klmm	8GP50-090h- h020klmm	8GP50-090h- h025klmm
<b>Gearbox</b>						
Number of gear stages	2					
Gear ratio i	9	12	15	16	20	25
Nominal output torque $T_{2N}$ [Nm]	97	90	82	90		82
Max. output torque $T_{2max}$ [Nm]	155	144	131	144		131
Emergency switch-off torque $T_{2stop}$ [Nm]	260	240	220	240		220
Idle torque [Nm] at 20°C and 3000 rpm	0.3		0.25			0.2
Max. average drive speed $n_{1N50\%}$ [rpm] at 50% $T_{2N}$ and S1	4000					
Max. average drive speed $n_{1N100\%}$ [rpm] at 100% $T_{2N}$ and S1	3450	4000				
Max. drive speed $n_{1max}$ [rpm]	7000					
Max. backlash $J_t$ [arcmin]	9					
Reduced backlash $J_t$ [arcmin] less than	0					
Torsional rigidity $C_{t21}$ [Nm/arcmin]	6.5					
Tilting rigidity $C_{2K}$ [Nm/arcmin]	0					
Max. breakdown torque $M_{2Kmax}$ [Nm]	0					
Max. radial force $F_{rmax}$ [N] for 30,000 h	1700					
Max. radial force $F_{rmax}$ [N] for 20,000 h	1900					
Max. axial force $F_{amax}$ [N] for 30,000 h	1500					
Max. axial force $F_{amax}$ [N] for 20,000 h	2000					
Operating noise $L_{pA}$ [dB(A)]	60					
Efficiency at full load $\eta$ [%]	94					
Min. operating temperature $B_{Tempmin}$ [°C]	-25					
Max. operating temperature $B_{Tempmax}$ [°C]	90					
Mounting orientation	Any					
Degree of protection	IP54					
Weight m [kg]	3.7					
Moment of inertia $J_1$ [kgcm <sup>2</sup> ]	0.75	0.73	0.71	0.5	0.44	

**Gear ratio 032 to 100**

Order number	8GP50-090hh032klmm	8GP50-090hh040klmm	8GP50-090hh064klmm	8GP50-090hh100klmm
<b>Gearbox</b>				
Number of gear stages	2			
Gear ratio $i$	32	40	64	100
Nominal output torque $T_{2N}$ [Nm]	90	82	50	38
Max. output torque $T_{2max}$ [Nm]	144	131	80	61
Emergency switch-off torque $T_{2stop}$ [Nm]	240	220	190	200
Idle torque [Nm] at 20°C and 3000 rpm	0.2			0.15
Max. average drive speed $n_{1N50\%}$ [rpm] at 50% $T_{2N}$ and S1	4000			
Max. average drive speed $n_{1N100\%}$ [rpm] at 100% $T_{2N}$ and S1	4000			
Max. drive speed $n_{1max}$ [rpm]	7000			
Max. backlash $J_i$ [arcmin]	9			
Reduced backlash $J_i$ [arcmin] less than	0			
Torsional rigidity $C_{t21}$ [Nm/arcmin]	6.5			
Tilting rigidity $C_{2K}$ [Nm/arcmin]	0			
Max. breakdown torque $M_{2Kmax}$ [Nm]	0			
Max. radial force $F_{rmax}$ [N] for 30,000 h	1700			
Max. radial force $F_{rmax}$ [N] for 20,000 h	1900			
Max. axial force $F_{amax}$ [N] for 30,000 h	1500			
Max. axial force $F_{amax}$ [N] for 20,000 h	2000			
Operating noise $L_{pA}$ [dB(A)]	60			
Efficiency at full load $\eta$ [%]	94			
Min. operating temperature $B_{Tempmin}$ [°C]	-25			
Max. operating temperature $B_{Tempmax}$ [°C]	90			
Mounting orientation	Any			
Degree of protection	IP54			
Weight $m$ [kg]	3.7			
Moment of inertia $J_1$ [kgcm <sup>2</sup> ]	0.39			

## 4.4.8.7 8GP55, gearbox size 060 - Technical data

## Gear ratio 003 to 016

Order number	8GP55-060h- h003klmm	8GP55-060h- h004klmm	8GP55-060h- h007klmm	8GP55-060h- h009klmm	8GP55-060h- h012klmm	8GP55-060h- h016klmm
<b>Gearbox</b>						
Number of gear stages	1			2		
Gear ratio i	3	4	7	9	12	16
Nominal output torque $T_{2N}$ [Nm]	28	38	25	44		
Max. output torque $T_{2max}$ [Nm]	45	61	40	70		
Emergency switch-off torque $T_{2stop}$ [Nm]	66	88	80	88		
Idle torque [Nm] at 20°C and 3000 rpm	0.5	0.35	0.2		0.15	
Max. average drive speed $n_{1N50\%}$ [rpm] at 50% $T_{2N}$ and S1	2950	3500	4500			
Max. average drive speed $n_{1N100\%}$ [rpm] at 100% $T_{2N}$ and S1	2500	2900	4500	4200	4500	
Max. drive speed $n_{1max}$ [rpm]	13000					
Max. backlash $J_i$ [arcmin]	10			12		
Reduced backlash $J_i$ [arcmin] less than	0					
Torsional rigidity $C_{21}$ [Nm/arcmin]	2.3			2.5		
Tilting rigidity $C_{2K}$ [Nm/arcmin]	0					
Max. breakdown torque $M_{2Kmax}$ [Nm]	0					
Max. radial force $F_{rmax}$ [N] for 30,000 h				3200		
Max. radial force $F_{rmax}$ [N] for 20,000 h				3200		
Max. axial force $F_{amax}$ [N] for 30,000 h				3900		
Max. axial force $F_{amax}$ [N] for 20,000 h				4400		
Operating noise $L_{PA}$ [dB(A)]	58					
Efficiency at full load $\eta$ [%]	96			94		
Min. operating temperature $B_{Tempmin}$ [°C]				-25		
Max. operating temperature $B_{Tempmax}$ [°C]				90		
Mounting orientation	Any					
Degree of protection	IP 65					
Weight m [kg]	1.4			1.6		
Moment of inertia $J_1$ [kgcm <sup>2</sup> ]	0.15	0.102	0.075	0.133	0.128	0.089

## 4.4.8.8 8GP55, gearbox size 080 - Technical data

## Gear ratio 003 to 010

Order number	8GP55-080h-h003klmm	8GP55-080h-h004klmm	8GP55-080h-h005klmm	8GP55-080h-h007klmm	8GP55-080h-h008klmm	8GP55-080h-h010klmm
<b>Gearbox</b>						
Number of gear stages	1					
Gear ratio i	3	4	5	7	8	10
Nominal output torque $T_{2N}$ [Nm]	85	115	110	65	50	38
Max. output torque $T_{2max}$ [Nm]	136	184	176	104	80	61
Emergency switch-off torque $T_{2stop}$ [Nm]	180	240	220	178	190	200
Idle torque [Nm] at 20°C and 3000 rpm	0.9	0.7	0.55	0.4	0.35	0.3
Max. average drive speed $n_{1N50\%}$ [rpm] at 50% $T_{2N}$ and S1	2450	2700	3250	4000		
Max. average drive speed $n_{1N100\%}$ [rpm] at 100% $T_{2N}$ and S1	1900	2000	2400	4000		
Max. drive speed $n_{1max}$ [rpm]	7000					
Max. backlash $J_1$ [arcmin]	7					
Reduced backlash $J_1$ [arcmin] less than	0					
Torsional rigidity $C_{21}$ [Nm/arcmin]	6					
Tilting rigidity $C_{2K}$ [Nm/arcmin]	0					
Max. breakdown torque $M_{2Kmax}$ [Nm]	0					
Max. radial force $F_{rmax}$ [N] for 30,000 h	4800					
Max. radial force $F_{rmax}$ [N] for 20,000 h	5500					
Max. axial force $F_{amax}$ [N] for 30,000 h	5700					
Max. axial force $F_{amax}$ [N] for 20,000 h	6400					
Operating noise $L_{PA}$ [dB(A)]	60					
Efficiency at full load $\eta$ [%]	96					
Min. operating temperature $B_{Tempmin}$ [°C]	-25					
Max. operating temperature $B_{Tempmax}$ [°C]	90					
Mounting orientation	Any					
Degree of protection	IP 65					
Weight m [kg]	2.7					
Moment of inertia $J_1$ [kgcm <sup>2</sup> ]	0.803	0.538	0.462	0.428	0.395	0.393

## Gear ratio 009 to 025

Order number	8GP55-080h- h009klmm	8GP55-080h- h012klmm	8GP55-080h- h015klmm	8GP55-080h- h016klmm	8GP55-080h- h020klmm	8GP55-080h- h025klmm
<b>Gearbox</b>						
Number of gear stages	2					
Gear ratio i	9	12	15	16	20	25
Nominal output torque $T_{2N}$ [Nm]	130	120	110	120		110
Max. output torque $T_{2max}$ [Nm]	208	192	176	192		176
Emergency switch-off torque $T_{2stop}$ [Nm]	260	240	220	240		220
Idle torque [Nm] at 20°C and 3000 rpm	0.4	0.35	0.3	0.35	0.25	
Max. average drive speed $n_{1N50\%}$ [rpm] at 50% $T_{2N}$ and S1	4000					
Max. average drive speed $n_{1N100\%}$ [rpm] at 100% $T_{2N}$ and S1	2850	3550	4000			
Max. drive speed $n_{1max}$ [rpm]	7000					
Max. backlash $J_t$ [arcmin]	9					
Reduced backlash $J_t$ [arcmin] less than	0					
Torsional rigidity $C_{t21}$ [Nm/arcmin]	6.5					
Tilting rigidity $C_{2K}$ [Nm/arcmin]	0					
Max. breakdown torque $M_{2Kmax}$ [Nm]	0					
Max. radial force $F_{rmax}$ [N] for 30,000 h	4800					
Max. radial force $F_{rmax}$ [N] for 20,000 h	5500					
Max. axial force $F_{amax}$ [N] for 30,000 h	5700					
Max. axial force $F_{amax}$ [N] for 20,000 h	6400					
Operating noise $L_{PA}$ [dB(A)]	60					
Efficiency at full load $\eta$ [%]	94					
Min. operating temperature $B_{Tempmin}$ [°C]	-25					
Max. operating temperature $B_{Tempmax}$ [°C]	90					
Mounting orientation	Any					
Degree of protection	IP 65					
Weight m [kg]	3.4					
Moment of inertia $J_1$ [kgcm <sup>2</sup> ]	0.744	0.722	0.71	0.5	0.44	

**Gear ratio 032 to 100**

Order number	8GP55-080hh032klmm	8GP55-080hh040klmm	8GP55-080hh064klmm	8GP55-080hh100klmm
<b>Gearbox</b>				
Number of gear stages	2			
Gear ratio $i$	32	40	64	100
Nominal output torque $T_{2N}$ [Nm]	120	110	50	38
Max. output torque $T_{2max}$ [Nm]	192	176	80	61
Emergency switch-off torque $T_{2stop}$ [Nm]	240	220	190	200
Idle torque [Nm] at 20°C and 3000 rpm	0.2			0.15
Max. average drive speed $n_{1N50\%}$ [rpm] at 50% $T_{2N}$ and S1	4000			
Max. average drive speed $n_{1N100\%}$ [rpm] at 100% $T_{2N}$ and S1	4000			
Max. drive speed $n_{1max}$ [rpm]	7000			
Max. backlash $J_i$ [arcmin]	9			
Reduced backlash $J_i$ [arcmin] less than	0			
Torsional rigidity $C_{t21}$ [Nm/arcmin]	6.5			
Tilting rigidity $C_{2K}$ [Nm/arcmin]	0			
Max. breakdown torque $M_{2Kmax}$ [Nm]	0			
Max. radial force $F_{rmax}$ [N] for 30,000 h	4800			
Max. radial force $F_{rmax}$ [N] for 20,000 h	5500			
Max. axial force $F_{amax}$ [N] for 30,000 h	5700			
Max. axial force $F_{amax}$ [N] for 20,000 h	6400			
Operating noise $L_{PA}$ [dB(A)]	60			
Efficiency at full load $\eta$ [%]	94			
Min. operating temperature $B_{Tempmin}$ [°C]	-25			
Max. operating temperature $B_{Tempmax}$ [°C]	90			
Mounting orientation	Any			
Degree of protection	IP 65			
Weight $m$ [kg]	3.4			
Moment of inertia $J_1$ [kgcm <sup>2</sup> ]	0.39			

## 4.4.8.9 8GP60, gearbox size 070 - Technical data

## Gear ratio 003 to 010

Order number	8GP60-070h-h003klmm	8GP60-070h-h004klmm	8GP60-070h-h005klmm	8GP60-070h-h007klmm	8GP60-070h-h008klmm	8GP60-070h-h010klmm
<b>Gearbox</b>						
Number of gear stages	1					
Gear ratio i	3	4	5	7	8	10
Nominal output torque $T_{2N}$ [Nm]	45	60	65	45	40	27
Max. output torque $T_{2max}$ [Nm]	72	96	104	72	64	43
Emergency switch-off torque $T_{2stop}$ [Nm]	90	120	130	80	90	
Idle torque [Nm] at 20°C and 3000 rpm	0.7	0.5	0.4	0.35	0.3	0.25
Max. average drive speed $n_{1N50\%}$ [rpm] at 50% $T_{2N}$ and S1	2050	2300	2650	3450	3800	4400
Max. average drive speed $n_{1N100\%}$ [rpm] at 100% $T_{2N}$ and S1	1700	1900	2100	2950	3300	4000
Max. drive speed $n_{1max}$ [rpm]	14000					
Max. backlash $J_1$ [arcmin]	3					
Reduced backlash $J_1$ [arcmin] less than	2					
Torsional rigidity $C_{21}$ [Nm/arcmin]	6					
Tilting rigidity $C_{2K}$ [Nm/arcmin]	0					
Max. breakdown torque $M_{2Kmax}$ [Nm]	0					
Max. radial force $F_{rmax}$ [N] for 30,000 h	3200					
Max. radial force $F_{rmax}$ [N] for 20,000 h	3200					
Max. axial force $F_{amax}$ [N] for 30,000 h	3900					
Max. axial force $F_{amax}$ [N] for 20,000 h	4400					
Operating noise $L_{PA}$ [dB(A)]	58					
Efficiency at full load $\eta$ [%]	98					
Min. operating temperature $B_{Tempmin}$ [°C]	-25					
Max. operating temperature $B_{Tempmax}$ [°C]	90					
Mounting orientation	Any					
Degree of protection	IP 65					
Weight m [kg]	1.9					
Moment of inertia $J_1$ [kgcm <sup>2</sup> ]	0.4	0.32	0.28	0.26	0.25	

## Gear ratio 012 to 032

Order number	8GP60-070h- h012klmm	8GP60-070h- h015klmm	8GP60-070h- h016klmm	8GP60-070h- h020klmm	8GP60-070h- h025klmm	8GP60-070h- h032klmm
<b>Gearbox</b>						
Number of gear stages	2					
Gear ratio i	12	15	16	20	25	32
Nominal output torque $T_{2N}$ [Nm]	68		77		65	77
Max. output torque $T_{2max}$ [Nm]	109		123		104	123
Emergency switch-off torque $T_{2stop}$ [Nm]	135		150			
Idle torque [Nm] at 20°C and 3000 rpm	0.35	0.3		0.25		0.2
Max. average drive speed $n_{1N50\%}$ [rpm] at 50% $T_{2N}$ and S1	3550	4000	3800	4300	4500	
Max. average drive speed $n_{1N100\%}$ [rpm] at 100% $T_{2N}$ and S1	2900	3300	3150	3600	4100	4500
Max. drive speed $n_{1max}$ [rpm]	14000					
Max. backlash $J_i$ [arcmin]	5					
Reduced backlash $J_i$ [arcmin] less than	2					
Torsional rigidity $C_{t21}$ [Nm/arcmin]	7					
Tilting rigidity $C_{2K}$ [Nm/arcmin]	0					
Max. breakdown torque $M_{2Kmax}$ [Nm]	0					
Max. radial force $F_{rmax}$ [N] for 30,000 h	3200					
Max. radial force $F_{rmax}$ [N] for 20,000 h	3200					
Max. axial force $F_{amax}$ [N] for 30,000 h	3900					
Max. axial force $F_{amax}$ [N] for 20,000 h	4400					
Operating noise $L_{PA}$ [dB(A)]	58					
Efficiency at full load $\eta$ [%]	95					
Min. operating temperature $B_{Tempmin}$ [°C]	-25					
Max. operating temperature $B_{Tempmax}$ [°C]	90					
Mounting orientation	Any					
Degree of protection	IP 65					
Weight m [kg]	2.4					
Moment of inertia $J_1$ [kgcm <sup>2</sup> ]	0.4	0.38	0.35	0.33	0.3	0.32

## Gear ratio 040 to 100

Order number	8GP60-070hh040klmm	8GP60-070hh064klmm	8GP60-070hh100klmm
<b>Gearbox</b>			
Number of gear stages	2		
Gear ratio i	40	64	100
Nominal output torque $T_{2N}$ [Nm]	65	40	27
Max. output torque $T_{2max}$ [Nm]	104	64	43
Emergency switch-off torque $T_{2stop}$ [Nm]	150	80	
Idle torque [Nm] at 20°C and 3000 rpm	0.2		
Max. average drive speed $n_{1N50\%}$ [rpm] at 50% $T_{2N}$ and S1	4500		
Max. average drive speed $n_{1N100\%}$ [rpm] at 100% $T_{2N}$ and S1	4500		
Max. drive speed $n_{1max}$ [rpm]	14000		
Max. backlash $J_t$ [arcmin]	5		
Reduced backlash $J_t$ [arcmin] less than	2		
Torsional rigidity $C_{t21}$ [Nm/arcmin]	7		
Tilting rigidity $C_{2K}$ [Nm/arcmin]	0		
Max. breakdown torque $M_{2Kmax}$ [Nm]	0		
Max. radial force $F_{rmax}$ [N] for 30,000 h	3200		
Max. radial force $F_{rmax}$ [N] for 20,000 h	3200		
Max. axial force $F_{amax}$ [N] for 30,000 h	3900		
Max. axial force $F_{amax}$ [N] for 20,000 h	4400		
Operating noise $L_{pA}$ [dB(A)]	58		
Efficiency at full load $\eta$ [%]	95		
Min. operating temperature $B_{Tempmin}$ [°C]	-25		
Max. operating temperature $B_{Tempmax}$ [°C]	90		
Mounting orientation	Any		
Degree of protection	IP 65		
Weight m [kg]	2.4		
Moment of inertia $J_1$ [kgcm <sup>2</sup> ]	0.29	0.26	0.25

## 4.4.8.10 8GP70, gearbox size 070 - Technical data

## Gear ratio 003 to 012

Order number	8GP70-070h-h003klmm	8GP70-070h-h004klmm	8GP70-070h-h005klmm	8GP70-070h-h007klmm	8GP70-070h-h010klmm	8GP70-070h-h012klmm
<b>Gearbox</b>						
Number of gear stages	1					2
Gear ratio i	3	4	5	7	10	12
Nominal output torque $T_{2N}$ [Nm]	29	39	40	37	28	29
Max. output torque $T_{2max}$ [Nm]	46	62	64	59	45	46
Emergency switch-off torque $T_{2stop}$ [Nm]	90	120	130	80	90	135
Idle torque [Nm] at 20°C and 3000 rpm	0.65	0.45	0.35	0.25	0.2	0.45
Max. average drive speed $n_{1N50\%}$ [rpm] at 50% $T_{2N}$ and S1	3000	3700	4400	4500		
Max. average drive speed $n_{1N100\%}$ [rpm] at 100% $T_{2N}$ and S1	2850	3400	4050	4500		
Max. drive speed $n_{1max}$ [rpm]	14000					
Max. backlash $J_1$ [arcmin]	3					5
Reduced backlash $J_1$ [arcmin] less than	2					
Torsional rigidity $C_{21}$ [Nm/arcmin]	5					
Tilting rigidity $C_{2K}$ [Nm/arcmin]	0					
Max. breakdown torque $M_{2Kmax}$ [Nm]	0					
Max. radial force $F_{rmax}$ [N] for 30,000 h	3200					
Max. radial force $F_{rmax}$ [N] for 20,000 h	3200					
Max. axial force $F_{amax}$ [N] for 30,000 h	3900					
Max. axial force $F_{amax}$ [N] for 20,000 h	4400					
Operating noise $L_{PA}$ [dB(A)]	63	57				
Efficiency at full load $\eta$ [%]	98					95
Min. operating temperature $B_{Tempmin}$ [°C]	-25					
Max. operating temperature $B_{Tempmax}$ [°C]	90					
Mounting orientation	Any					
Degree of protection	IP 65					
Weight m [kg]	1.9					2.7
Moment of inertia $J_1$ [kgcm <sup>2</sup> ]	0.273	0.191	0.163	0.137	0.125	0.18

## Gear ratio 015 to 040

Order number	8GP70-070h- h015klmm	8GP70-070h- h016klmm	8GP70-070h- h020klmm	8GP70-070h- h025klmm	8GP70-070h- h035klmm	8GP70-070h- h040klmm
<b>Gearbox</b>						
Number of gear stages	2					
Gear ratio i	15	16	20	25	35	40
Nominal output torque $T_{2N}$ [Nm]	29	39		40		39
Max. output torque $T_{2max}$ [Nm]	46	62		64		62
Emergency switch-off torque $T_{2stop}$ [Nm]	135	150				
Idle torque [Nm] at 20°C and 3000 rpm	0.3	0.4	0.3		0.2	0.15
Max. average drive speed $n_{1N50\%}$ [rpm] at 50% $T_{2N}$ and S1	4500					
Max. average drive speed $n_{1N100\%}$ [rpm] at 100% $T_{2N}$ and S1	4500					
Max. drive speed $n_{1max}$ [rpm]	14000					
Max. backlash $J_t$ [arcmin]	5					
Reduced backlash $J_t$ [arcmin] less than	2					
Torsional rigidity $C_{t21}$ [Nm/arcmin]	5					
Tilting rigidity $C_{2K}$ [Nm/arcmin]	0					
Max. breakdown torque $M_{2Kmax}$ [Nm]	0					
Max. radial force $F_{rmax}$ [N] for 30,000 h	3200					
Max. radial force $F_{rmax}$ [N] for 20,000 h	3200					
Max. axial force $F_{amax}$ [N] for 30,000 h	3900					
Max. axial force $F_{amax}$ [N] for 20,000 h	4400					
Operating noise $L_{PA}$ [dB(A)]	57					
Efficiency at full load $\eta$ [%]	95					
Min. operating temperature $B_{Tempmin}$ [°C]	-25					
Max. operating temperature $B_{Tempmax}$ [°C]	90					
Mounting orientation	Any					
Degree of protection	IP 65					
Weight m [kg]	2.7					
Moment of inertia $J_1$ [kgcm <sup>2</sup> ]	0.156	0.175	0.152	0.151	0.131	0.123

**Gear ratio 050 to 100**

Order number	8GP70-070hh050klmm	8GP70-070hh070klmm	8GP70-070hh100klmm
<b>Gearbox</b>			
Number of gear stages	2		
Gear ratio i	50	70	100
Nominal output torque $T_{2N}$ [Nm]	40	37	28
Max. output torque $T_{2max}$ [Nm]	64	59	45
Emergency switch-off torque $T_{2stop}$ [Nm]	150	80	
Idle torque [Nm] at 20°C and 3000 rpm	0.15		
Max. average drive speed $n_{1N50\%}$ [rpm] at 50% $T_{2N}$ and S1	4500		
Max. average drive speed $n_{1N100\%}$ [rpm] at 100% $T_{2N}$ and S1	4500		
Max. drive speed $n_{1max}$ [rpm]	14000		
Max. backlash $J_t$ [arcmin]	5		
Reduced backlash $J_t$ [arcmin] less than	2		
Torsional rigidity $C_{t21}$ [Nm/arcmin]	5		
Tilting rigidity $C_{2K}$ [Nm/arcmin]	0		
Max. breakdown torque $M_{2Kmax}$ [Nm]	0		
Max. radial force $F_{rmax}$ [N] for 30,000 h	3200		
Max. radial force $F_{rmax}$ [N] for 20,000 h	3200		
Max. axial force $F_{amax}$ [N] for 30,000 h	3900		
Max. axial force $F_{amax}$ [N] for 20,000 h	4400		
Operating noise $L_{PA}$ [dB(A)]	57		
Efficiency at full load $\eta$ [%]	95		
Min. operating temperature $B_{Tempmin}$ [°C]	-25		
Max. operating temperature $B_{Tempmax}$ [°C]	90		
Mounting orientation	Any		
Degree of protection	IP 65		
Weight m [kg]	2.7		
Moment of inertia $J_1$ [kgcm <sup>2</sup> ]	0.122		

## 4.4.8.11 8GF40, gearbox size 064 - Technical data

## Gear ratio 003 to 016

Order number	8GF40-064h- h003klmm	8GF40-064h- h004klmm	8GF40-064h- h007klmm	8GF40-064h- h009klmm	8GF40-064h- h012klmm	8GF40-064h- h016klmm
<b>Gearbox</b>						
Number of gear stages	1		-		2	
Gear ratio i	3	4	7	9	12	16
Nominal output torque $T_{2N}$ [Nm]	28	38	25.0	44		
Max. output torque $T_{2max}$ [Nm]	45	61	40.0	70		
Emergency switch-off torque $T_{2stop}$ [Nm]	66	88	80	88		
Idle torque [Nm] at 20°C and 3000 rpm	0.3	0.2	0.15			0.1
Max. average drive speed $n_{1N50\%}$ [rpm] at 50% $T_{2N}$ and S1	3950	4500				
Max. average drive speed $n_{1N100\%}$ [rpm] at 100% $T_{2N}$ and S1	3200	3450	4500	4400	4500	
Max. drive speed $n_{1max}$ [rpm]	13000					
Max. backlash $J_1$ [arcmin]	10			12		
Reduced backlash $J_1$ [arcmin] less than	0		0	0		
Torsional rigidity $C_{21}$ [Nm/arcmin]	18		18.0	12		
Tilting rigidity $C_{2K}$ [Nm/arcmin]	0		0.0	0		
Max. breakdown torque $M_{2Kmax}$ [Nm]	0		0.0	0		
Max. radial force $F_{rmax}$ [N] for 30,000 h	500					
Max. radial force $F_{rmax}$ [N] for 20,000 h	550					
Max. axial force $F_{amax}$ [N] for 30,000 h	1200					
Max. axial force $F_{amax}$ [N] for 20,000 h	1200					
Operating noise $L_{PA}$ [dB(A)]	58					
Efficiency at full load $\eta$ [%]	96			94		
Min. operating temperature $B_{Tempmin}$ [°C]	-25					
Max. operating temperature $B_{Tempmax}$ [°C]	90					
Mounting orientation	Any		-		Any	
Degree of protection	IP54		-		IP54	
Weight m [kg]	1.1		1.10	1.5		
Moment of inertia $J_1$ [kgcm <sup>2</sup> ]	0.183	0.123	0.084	0.145	0.134	0.101

## 4.4.8.12 8GF60, gearbox size 064 - Technical data

## Gear ratio 004 to 016

Order number	8GF60-064h-h004klmm	8GF60-064h-h005klmm	8GF60-064h-h007klmm	8GF60-064h-h008klmm	8GF60-064h-h010klmm	8GF60-064h-h016klmm
<b>Gearbox</b>						
Number of gear stages	1		-	1		2
Gear ratio i	4	5	7	8	10	16
Nominal output torque $T_{2N}$ [Nm]	60	65	45.0	40	27	77
Max. output torque $T_{2max}$ [Nm]	96	104	72.0	64	43	123
Emergency switch-off torque $T_{2stop}$ [Nm]	120	130	90			150
Idle torque [Nm] at 20°C and 3000 rpm	0.7	0.55	0.40	0.35	0.3	0.35
Max. average drive speed $n_{1N50\%}$ [rpm] at 50% $T_{2N}$ and S1	2100	2450	3200	3550	4100	3700
Max. average drive speed $n_{1N100\%}$ [rpm] at 100% $T_{2N}$ and S1	1750	2000	2800	3100	3800	3050
Max. drive speed $n_{1max}$ [rpm]	14000					
Max. backlash $J_i$ [arcmin]	3		3	3		5
Reduced backlash $J_i$ [arcmin] less than	2					
Torsional rigidity $C_{t21}$ [Nm/arcmin]	16		16.0	16		14
Tilting rigidity $C_{2K}$ [Nm/arcmin]	117		117.0	117		
Max. breakdown torque $M_{2Kmax}$ [Nm]	148		148.0	148		
Max. radial force $F_{rmax}$ [N] for 30,000 h	2100					
Max. radial force $F_{rmax}$ [N] for 20,000 h	2400					
Max. axial force $F_{amax}$ [N] for 30,000 h	3800					
Max. axial force $F_{amax}$ [N] for 20,000 h	4300					
Operating noise $L_{PA}$ [dB(A)]	65					
Efficiency at full load $\eta$ [%]	98					95
Min. operating temperature $B_{Tempmin}$ [°C]	-25					
Max. operating temperature $B_{Tempmax}$ [°C]	90					
Mounting orientation	Any		-	Any		
Degree of protection	IP 65		-	IP 65		
Weight m [kg]	1.5		1.50	1.5		2.2
Moment of inertia $J_1$ [kgcm <sup>2</sup> ]	0.29	0.26	0.240	0.22	0.21	0.32

## Gear ratio 020 to 064

Order number	8GF60-064h- h020klmm	8GF60-064h- h025klmm	8GF60-064h- h032klmm	8GF60-064h- h040klmm	8GF60-064h- h050klmm	8GF60-064h- h064klmm
<b>Gearbox</b>						
Number of gear stages	2					
Gear ratio i	20	25	32	40	50	64
Nominal output torque $T_{2N}$ [Nm]	77	65	77	65		40
Max. output torque $T_{2max}$ [Nm]	123	104	123	104		64
Emergency switch-off torque $T_{2stop}$ [Nm]	150					80
Idle torque [Nm] at 20°C and 3000 rpm	0.3	0.25		0.2		
Max. average drive speed $n_{1N50\%}$ [rpm] at 50% $T_{2N}$ and S1	4200	4500				
Max. average drive speed $n_{1N100\%}$ [rpm] at 100% $T_{2N}$ and S1	3500	4000	4400	4500		
Max. drive speed $n_{1max}$ [rpm]	14000					
Max. backlash $J_t$ [arcmin]	5					
Reduced backlash $J_t$ [arcmin] less than	2					
Torsional rigidity $C_{t21}$ [Nm/arcmin]	14					
Tilting rigidity $C_{2K}$ [Nm/arcmin]	117					
Max. breakdown torque $M_{2Kmax}$ [Nm]	148					
Max. radial force $F_{rmax}$ [N] for 30,000 h	2100					
Max. radial force $F_{rmax}$ [N] for 20,000 h	2400					
Max. axial force $F_{amax}$ [N] for 30,000 h	3800					
Max. axial force $F_{amax}$ [N] for 20,000 h	4300					
Operating noise $L_{PA}$ [dB(A)]	65					
Efficiency at full load $\eta$ [%]	95					
Min. operating temperature $B_{Tempmin}$ [°C]	-25					
Max. operating temperature $B_{Tempmax}$ [°C]	90					
Mounting orientation	Any					
Degree of protection	IP 65					
Weight m [kg]	2.2					
Moment of inertia $J_1$ [kgcm <sup>2</sup> ]	0.3	0.27	0.29	0.26	0.22	0.23

### Gear ratio 100

Order number	8GF60-064hh100klmm
<b>Gearbox</b>	
Number of gear stages	2
Gear ratio $i$	100
Nominal output torque $T_{2N}$ [Nm]	27
Max. output torque $T_{2max}$ [Nm]	43
Emergency switch-off torque $T_{2stop}$ [Nm]	80
Idle torque [Nm] at 20°C and 3000 rpm	0.2
Max. average drive speed $n_{1N50\%}$ [rpm] at 50% $T_{2N}$ and S1	4500
Max. average drive speed $n_{1N100\%}$ [rpm] at 100% $T_{2N}$ and S1	4500
Max. drive speed $n_{1max}$ [rpm]	14000
Max. backlash $J_t$ [arcmin]	5
Reduced backlash $J_t$ [arcmin] less than	2
Torsional rigidity $C_{t21}$ [Nm/arcmin]	14
Tilting rigidity $C_{2K}$ [Nm/arcmin]	117
Max. breakdown torque $M_{2Kmax}$ [Nm]	148
Max. radial force $F_{rmax}$ [N] for 30,000 h	2100
Max. radial force $F_{rmax}$ [N] for 20,000 h	2400
Max. axial force $F_{amax}$ [N] for 30,000 h	3800
Max. axial force $F_{amax}$ [N] for 20,000 h	4300
Operating noise $L_{pA}$ [dB(A)]	65
Efficiency at full load $\eta$ [%]	95
Min. operating temperature $B_{Tempmin}$ [°C]	-25
Max. operating temperature $B_{Tempmax}$ [°C]	90
Mounting orientation	Any
Degree of protection	IP 65
Weight $m$ [kg]	2.2
Moment of inertia $J_1$ [kgcm <sup>2</sup> ]	0.22

## 4.4.8.13 8GF70, gearbox size 064 - Technical data

## Gear ratio 004 to 020

Order number	8GF70-064h-h004klmm	8GF70-064h-h005klmm	8GF70-064h-h007klmm	8GF70-064h-h010klmm	8GF70-064h-h016klmm	8GF70-064h-h020klmm
<b>Gearbox</b>						
Number of gear stages	1			2		
Gear ratio i	4	5	7	10	16	20
Nominal output torque $T_{2N}$ [Nm]	39	40	37	28	39	
Max. output torque $T_{2max}$ [Nm]	62	64	59	45	62	
Emergency switch-off torque $T_{2stop}$ [Nm]	120	130	80	90	150	
Idle torque [Nm] at 20°C and 3000 rpm	0.65	0.5	0.35	0.25	0.45	0.3
Max. average drive speed $n_{1N50\%}$ [rpm] at 50% $T_{2N}$ and S1	3200	3800	4500			
Max. average drive speed $n_{1N100\%}$ [rpm] at 100% $T_{2N}$ and S1	3000	3600	4500			
Max. drive speed $n_{1max}$ [rpm]	14000					
Max. backlash $J_1$ [arcmin]	3				5	
Reduced backlash $J_1$ [arcmin] less than	2					
Torsional rigidity $C_{21}$ [Nm/arcmin]	16				14	
Tilting rigidity $C_{2K}$ [Nm/arcmin]	117					
Max. breakdown torque $M_{2Kmax}$ [Nm]	148					
Max. radial force $F_{rmax}$ [N] for 30,000 h	2100					
Max. radial force $F_{rmax}$ [N] for 20,000 h	2400					
Max. axial force $F_{amax}$ [N] for 30,000 h	3800					
Max. axial force $F_{amax}$ [N] for 20,000 h	4300					
Operating noise $L_{PA}$ [dB(A)]	57					
Efficiency at full load $\eta$ [%]	98				95	
Min. operating temperature $B_{Tempmin}$ [°C]	-25					
Max. operating temperature $B_{Tempmax}$ [°C]	90					
Mounting orientation	Any					
Degree of protection	IP 65					
Weight m [kg]	1.5				2.2	
Moment of inertia $J_1$ [kgcm <sup>2</sup> ]	0.192	0.163	0.138	0.125	0.175	0.152

**Gear ratio 025 to 100**

Order number	8GF70-064h- h025klmm	8GF70-064h- h035klmm	8GF70-064h- h040klmm	8GF70-064h- h050klmm	8GF70-064h- h070klmm	8GF70-064h- h100klmm
<b>Gearbox</b>						
Number of gear stages	2					
Gear ratio i	25	35	40	50	70	100
Nominal output torque $T_{2N}$ [Nm]	40		39	40	37	28
Max. output torque $T_{2max}$ [Nm]	64		62	64	59	45
Emergency switch-off torque $T_{2stop}$ [Nm]	150				80	90
Idle torque [Nm] at 20°C and 3000 rpm	0.3	0.2	0.15			
Max. average drive speed $n_{1N50\%}$ [rpm] at 50% $T_{2N}$ and S1	4500					
Max. average drive speed $n_{1N100\%}$ [rpm] at 100% $T_{2N}$ and S1	4500					
Max. drive speed $n_{1max}$ [rpm]	14000					
Max. backlash $J_t$ [arcmin]	5					
Reduced backlash $J_t$ [arcmin] less than	2					
Torsional rigidity $C_{t21}$ [Nm/arcmin]	14					
Tilting rigidity $C_{2K}$ [Nm/arcmin]	117					
Max. breakdown torque $M_{2Kmax}$ [Nm]	148					
Max. radial force $F_{rmax}$ [N] for 30,000 h	2100					
Max. radial force $F_{rmax}$ [N] for 20,000 h	2400					
Max. axial force $F_{amax}$ [N] for 30,000 h	3800					
Max. axial force $F_{amax}$ [N] for 20,000 h	4300					
Operating noise $L_{PA}$ [dB(A)]	57					
Efficiency at full load $\eta$ [%]	95					
Min. operating temperature $B_{Tempmin}$ [°C]	-25					
Max. operating temperature $B_{Tempmax}$ [°C]	90					
Mounting orientation	Any					
Degree of protection	IP 65					
Weight m [kg]	2.2					
Moment of inertia $J_1$ [kgcm <sup>2</sup> ]	0.151	0.131	0.123	0.122		

## 4.4.8.14 8GA40, gearbox size 060 - Technical data

## Gear ratio 003 to 009

Order number	8GA40-060h-h003klmm	8GA40-060h-h004klmm	8GA40-060h-h005klmm	8GA40-060h-h007klmm	8GA40-060h-h008klmm	8GA40-060h-h009klmm
<b>Gearbox</b>						
Number of gear stages	1			-	1	2
Gear ratio i	3	4	5	7	8	9
Nominal output torque $T_{2N}$ [Nm]	14	19	24	25.0	18	44
Max. output torque $T_{2max}$ [Nm]	22	30	38	40.0	29	70
Emergency switch-off torque $T_{2stop}$ [Nm]	66	86	80			88
Idle torque [Nm] at 20°C and 3000 rpm	0.25		0.2	0.20	0.2	0.25
Max. average drive speed $n_{1N50\%}$ [rpm] at 50% $T_{2N}$ and S1	4500					
Max. average drive speed $n_{1N100\%}$ [rpm] at 100% $T_{2N}$ and S1	3900	3950	4000	4500		3550
Max. drive speed $n_{1max}$ [rpm]	13000					
Max. backlash $J_i$ [arcmin]	16					18
Reduced backlash $J_i$ [arcmin] less than	0			0	0	
Torsional rigidity $C_{t21}$ [Nm/arcmin]	1.5					2.5
Tilting rigidity $C_{2K}$ [Nm/arcmin]	0			0.0	0	
Max. breakdown torque $M_{2Kmax}$ [Nm]	0			0.0	0	
Max. radial force $F_{rmax}$ [N] for 30,000 h	340					
Max. radial force $F_{rmax}$ [N] for 20,000 h	400					
Max. axial force $F_{amax}$ [N] for 30,000 h	450					
Max. axial force $F_{amax}$ [N] for 20,000 h	500					
Operating noise $L_{PA}$ [dB(A)]	70					
Efficiency at full load $\eta$ [%]	94					92
Min. operating temperature $B_{Tempmin}$ [°C]	-25					
Max. operating temperature $B_{Tempmax}$ [°C]	90					
Mounting orientation	Any			-	Any	
Degree of protection	IP54			-	IP54	
Weight m [kg]	1.7		1.70	1.7	1.9	
Moment of inertia $J_1$ [kgcm <sup>2</sup> ]	0.246	0.204	0.189	0.183	0.176	0.242

**Gear ratio 010 to 025**

Order number	8GA40-060h-h010klmm	8GA40-060h-h012klmm	8GA40-060h-h015klmm	8GA40-060h-h016klmm	8GA40-060h-h020klmm	8GA40-060h-h025klmm
<b>Gearbox</b>						
Number of gear stages	1		2			
Gear ratio i	10	12	15	16	20	25
Nominal output torque $T_{2N}$ [Nm]	15	44				40
Max. output torque $T_{2max}$ [Nm]	24	70				64
Emergency switch-off torque $T_{2stop}$ [Nm]	70	88				80
Idle torque [Nm] at 20°C and 3000 rpm	0.2	0.25	0.2			
Max. average drive speed $n_{1N50\%}$ [rpm] at 50% $T_{2N}$ and S1	4500					
Max. average drive speed $n_{1N100\%}$ [rpm] at 100% $T_{2N}$ and S1	4500	4150	4500			
Max. drive speed $n_{1max}$ [rpm]	13000					
Max. backlash $J_t$ [arcmin]	16	18				
Reduced backlash $J_t$ [arcmin] less than	0					
Torsional rigidity $C_{t21}$ [Nm/arcmin]	1.5	2.5				
Tilting rigidity $C_{2K}$ [Nm/arcmin]	0					
Max. breakdown torque $M_{2Kmax}$ [Nm]	0					
Max. radial force $F_{rmax}$ [N] for 30,000 h	340					
Max. radial force $F_{rmax}$ [N] for 20,000 h	400					
Max. axial force $F_{amax}$ [N] for 30,000 h	450					
Max. axial force $F_{amax}$ [N] for 20,000 h	500					
Operating noise $L_{PA}$ [dB(A)]	70					
Efficiency at full load $\eta$ [%]	94	92				
Min. operating temperature $B_{Tempmin}$ [°C]	-25					
Max. operating temperature $B_{Tempmax}$ [°C]	90					
Mounting orientation	Any					
Degree of protection	IP54					
Weight m [kg]	1.7	1.9				
Moment of inertia $J_1$ [kgcm <sup>2</sup> ]	0.175	0.238	0.188	0.199	0.186	

## Gear ratio 032 to 100

Order number	8GA40-060h- h032klmm	8GA40-060h- h040klmm	8GA40-060h- h060klmm	8GA40-060h- h064klmm	8GA40-060h- h080klmm	8GA40-060h- h100klmm
<b>Gearbox</b>						
Number of gear stages	2		3	2	3	2
Gear ratio i	32	40	60	64	80	100
Nominal output torque $T_{2N}$ [Nm]	44	40	44	18	44	15
Max. output torque $T_{2max}$ [Nm]	70	64	70	29	70	24
Emergency switch-off torque $T_{2stop}$ [Nm]	88	80	88	80	88	80
Idle torque [Nm] at 20°C and 3000 rpm	0.2					
Max. average drive speed $n_{1N50\%}$ [rpm] at 50% $T_{2N}$ and S1	4500					
Max. average drive speed $n_{1N100\%}$ [rpm] at 100% $T_{2N}$ and S1	4500					
Max. drive speed $n_{1max}$ [rpm]	13000					
Max. backlash $J_i$ [arcmin]	18		21	18	21	18
Reduced backlash $J_i$ [arcmin] less than	0					
Torsional rigidity $C_{t21}$ [Nm/arcmin]	2.5					
Tilting rigidity $C_{2K}$ [Nm/arcmin]	0					
Max. breakdown torque $M_{2Kmax}$ [Nm]	0					
Max. radial force $F_{rmax}$ [N] for 30,000 h	340					
Max. radial force $F_{rmax}$ [N] for 20,000 h	400					
Max. axial force $F_{amax}$ [N] for 30,000 h	450					
Max. axial force $F_{amax}$ [N] for 20,000 h	500					
Operating noise $L_{PA}$ [dB(A)]	70					
Efficiency at full load $\eta$ [%]	92		88	92	88	92
Min. operating temperature $B_{Tempmin}$ [°C]	-25					
Max. operating temperature $B_{Tempmax}$ [°C]	90					
Mounting orientation	Any					
Degree of protection	IP54					
Weight m [kg]	1.9		2.1	1.9	2.1	1.9
Moment of inertia $J_1$ [kgcm <sup>2</sup> ]	0.175		0.187	0.175	0.186	0.175

## 4.4.8.15 8GA40, gearbox size 080 - Technical data

## Gear ratio 003 to 009

Order number	8GA40-080h-h003klmm	8GA40-080h-h004klmm	8GA40-080h-h005klmm	8GA40-080h-h007klmm	8GA40-080h-h008klmm	8GA40-080h-h009klmm
<b>Gearbox</b>						
Number of gear stages	1			-	1	2
Gear ratio i	3	4	5	7	8	9
Nominal output torque $T_{2N}$ [Nm]	40	53	67	65.0	50	130
Max. output torque $T_{2max}$ [Nm]	64	85	107	104.0	80	208
Emergency switch-off torque $T_{2stop}$ [Nm]	180	240	220	178	190	260
Idle torque [Nm] at 20°C and 3000 rpm	0.6		0.55	0.50	0.5	0.55
Max. average drive speed $n_{1N50\%}$ [rpm] at 50% $T_{2N}$ and S1	3500	3550	3600	4000		3250
Max. average drive speed $n_{1N100\%}$ [rpm] at 100% $T_{2N}$ and S1	2500	2450		3100	3800	2100
Max. drive speed $n_{1max}$ [rpm]	7000					
Max. backlash $J_i$ [arcmin]	13					15
Reduced backlash $J_i$ [arcmin] less than	0			0	0	
Torsional rigidity $C_{t21}$ [Nm/arcmin]	4.5					6.5
Tilting rigidity $C_{2K}$ [Nm/arcmin]	0			0.0	0	
Max. breakdown torque $M_{2Kmax}$ [Nm]	0			0.0	0	
Max. radial force $F_{rmax}$ [N] for 30,000 h	650					
Max. radial force $F_{rmax}$ [N] for 20,000 h	750					
Max. axial force $F_{amax}$ [N] for 30,000 h	900					
Max. axial force $F_{amax}$ [N] for 20,000 h	1000					
Operating noise $L_{PA}$ [dB(A)]	73					
Efficiency at full load $\eta$ [%]	94					92
Min. operating temperature $B_{Tempmin}$ [°C]	-25					
Max. operating temperature $B_{Tempmax}$ [°C]	90					
Mounting orientation	Any			-	Any	
Degree of protection	IP54			-	IP54	
Weight m [kg]	4.4			4.40	4.4	5
Moment of inertia $J_1$ [kgcm <sup>2</sup> ]	1.189	0.939	0.869	0.839	0.809	1.159

## Gear ratio 010 to 025

Order number	8GA40-080h-h010klmm	8GA40-080h-h012klmm	8GA40-080h-h015klmm	8GA40-080h-h016klmm	8GA40-080h-h020klmm	8GA40-080h-h025klmm	
<b>Gearbox</b>							
Number of gear stages	1	2					
Gear ratio i	10	12	15	16	20	25	
Nominal output torque $T_{2N}$ [Nm]	38	120	110	120		110	
Max. output torque $T_{2max}$ [Nm]	61	192	176	192		176	
Emergency switch-off torque $T_{2stop}$ [Nm]	170	240	220	240		220	
Idle torque [Nm] at 20°C and 3000 rpm	0.5	0.55	0.5	0.55	0.5		
Max. average drive speed $n_{1N50\%}$ [rpm] at 50% $T_{2N}$ and S1	4000	3850	4000				
Max. average drive speed $n_{1N100\%}$ [rpm] at 100% $T_{2N}$ and S1	4000	2650	3150	3100	3550	4000	
Max. drive speed $n_{1max}$ [rpm]	7000						
Max. backlash $J_t$ [arcmin]	13	15					
Reduced backlash $J_t$ [arcmin] less than	0						
Torsional rigidity $C_{t21}$ [Nm/arcmin]	4.5	6.5					
Tilting rigidity $C_{2K}$ [Nm/arcmin]	0						
Max. breakdown torque $M_{2Kmax}$ [Nm]	0						
Max. radial force $F_{rmax}$ [N] for 30,000 h				650			
Max. radial force $F_{rmax}$ [N] for 20,000 h				750			
Max. axial force $F_{amax}$ [N] for 30,000 h				900			
Max. axial force $F_{amax}$ [N] for 20,000 h				1000			
Operating noise $L_{PA}$ [dB(A)]				73			
Efficiency at full load $\eta$ [%]	94	92					
Min. operating temperature $B_{Tempmin}$ [°C]				-25			
Max. operating temperature $B_{Tempmax}$ [°C]				90			
Mounting orientation				Any			
Degree of protection	IP54						
Weight m [kg]	4.4	5					
Moment of inertia $J_1$ [kgcm <sup>2</sup> ]	0.809	1.139	1.129	0.919	0.859		

## Gear ratio 032 to 100

Order number	8GA40-080h- h032klmm	8GA40-080h- h040klmm	8GA40-080h- h064klmm	8GA40-080h- h060klmm	8GA40-080h- h080klmm	8GA40-080h- h100klmm
<b>Gearbox</b>						
Number of gear stages	2			3		2
Gear ratio i	32	40	64	60	80	100
Nominal output torque $T_{2N}$ [Nm]	120	110	50	110	120	38
Max. output torque $T_{2max}$ [Nm]	192	176	80	176	192	61
Emergency switch-off torque $T_{2stop}$ [Nm]	240	220	190	220	240	170
Idle torque [Nm] at 20°C and 3000 rpm	0.45			0.5		0.45
Max. average drive speed $n_{1N50\%}$ [rpm] at 50% $T_{2N}$ and S1	4000					
Max. average drive speed $n_{1N100\%}$ [rpm] at 100% $T_{2N}$ and S1	4000					
Max. drive speed $n_{1max}$ [rpm]	7000					
Max. backlash $J_t$ [arcmin]	15			17		15
Reduced backlash $J_t$ [arcmin] less than	0					
Torsional rigidity $C_{t21}$ [Nm/arcmin]	6.5			6.3		6.5
Tilting rigidity $C_{2K}$ [Nm/arcmin]	0					
Max. breakdown torque $M_{2Kmax}$ [Nm]	0					
Max. radial force $F_{rmax}$ [N] for 30,000 h	650					
Max. radial force $F_{rmax}$ [N] for 20,000 h	750					
Max. axial force $F_{amax}$ [N] for 30,000 h	900					
Max. axial force $F_{amax}$ [N] for 20,000 h	1000					
Operating noise $L_{PA}$ [dB(A)]	73					
Efficiency at full load $\eta$ [%]	92			88		92
Min. operating temperature $B_{Tempmin}$ [°C]	-25					
Max. operating temperature $B_{Tempmax}$ [°C]	90					
Mounting orientation	Any					
Degree of protection	IP54					
Weight m [kg]	5			5.5		5
Moment of inertia $J_1$ [kgcm <sup>2</sup> ]	0.809			0.929	0.919	0.809

## 4.4.8.16 8GA45, gearbox size 067 - Technical data

## Gear ratio 003 to 009

Order number	8GA45-067h-h003klmm	8GA45-067h-h004klmm	8GA45-067h-h005klmm	8GA45-067h-h007klmm	8GA45-067h-h008klmm	8GA45-067h-h009klmm
<b>Gearbox</b>						
Number of gear stages	1					2
Gear ratio i	3	4	5	7	8	9
Nominal output torque $T_{2N}$ [Nm]	14	19	24	25	18	44
Max. output torque $T_{2max}$ [Nm]	22	30	38	40	29	70
Emergency switch-off torque $T_{2stop}$ [Nm]	66	86	80			88
Idle torque [Nm] at 20°C and 3000 rpm	0.3	0.25			0.2	0.25
Max. average drive speed $n_{1N50\%}$ [rpm] at 50% $T_{2N}$ and S1	4500					
Max. average drive speed $n_{1N100\%}$ [rpm] at 100% $T_{2N}$ and S1	3700	3800	3850	4500		3500
Max. drive speed $n_{1max}$ [rpm]	13000					
Max. backlash $J_1$ [arcmin]	16					18
Reduced backlash $J_1$ [arcmin] less than	0					
Torsional rigidity $C_{21}$ [Nm/arcmin]	1.5					2.5
Tilting rigidity $C_{2K}$ [Nm/arcmin]	0					
Max. breakdown torque $M_{2Kmax}$ [Nm]	0					
Max. radial force $F_{rmax}$ [N] for 30,000 h	700					
Max. radial force $F_{rmax}$ [N] for 20,000 h	900					
Max. axial force $F_{amax}$ [N] for 30,000 h	800					
Max. axial force $F_{amax}$ [N] for 20,000 h	1000					
Operating noise $L_{PA}$ [dB(A)]	70					
Efficiency at full load $\eta$ [%]	94					92
Min. operating temperature $B_{Tempmin}$ [°C]	-25					
Max. operating temperature $B_{Tempmax}$ [°C]	90					
Mounting orientation	Any					
Degree of protection	IP54					
Weight m [kg]	1.9					2.1
Moment of inertia $J_1$ [kgcm <sup>2</sup> ]	0.246	0.204	0.189	0.183	0.176	0.242

## Gear ratio 010 to 025

Order number	8GA45-067h-h010klmm	8GA45-067h-h012klmm	8GA45-067h-h015klmm	8GA45-067h-h016klmm	8GA45-067h-h020klmm	8GA45-067h-h025klmm
<b>Gearbox</b>						
Number of gear stages	1	2				
Gear ratio i	10	12	15	16	20	25
Nominal output torque $T_{2N}$ [Nm]	15	44				40
Max. output torque $T_{2max}$ [Nm]	24	70				64
Emergency switch-off torque $T_{2stop}$ [Nm]	70	88				80
Idle torque [Nm] at 20°C and 3000 rpm	0.2	0.25	0.2			
Max. average drive speed $n_{1N50\%}$ [rpm] at 50% $T_{2N}$ and S1	4500					
Max. average drive speed $n_{1N100\%}$ [rpm] at 100% $T_{2N}$ and S1	4500	4100	4500			
Max. drive speed $n_{1max}$ [rpm]	13000					
Max. backlash $J_t$ [arcmin]	16	18				
Reduced backlash $J_t$ [arcmin] less than	0					
Torsional rigidity $C_{t21}$ [Nm/arcmin]	1.5	2.5				
Tilting rigidity $C_{2K}$ [Nm/arcmin]	0					
Max. breakdown torque $M_{2Kmax}$ [Nm]	0					
Max. radial force $F_{rmax}$ [N] for 30,000 h	700					
Max. radial force $F_{rmax}$ [N] for 20,000 h	900					
Max. axial force $F_{amax}$ [N] for 30,000 h	800					
Max. axial force $F_{amax}$ [N] for 20,000 h	1000					
Operating noise $L_{PA}$ [dB(A)]	70					
Efficiency at full load $\eta$ [%]	94	92				
Min. operating temperature $B_{Tempmin}$ [°C]	-25					
Max. operating temperature $B_{Tempmax}$ [°C]	90					
Mounting orientation	Any					
Degree of protection	IP54					
Weight m [kg]	1.9	2.1				
Moment of inertia $J_1$ [kgcm <sup>2</sup> ]	0.175	0.238	0.188	0.199	0.186	

## Gear ratio 032 to 100

Order number	8GA45-067h-h032klmm	8GA45-067h-h040klmm	8GA45-067h-h060klmm	8GA45-067h-h064klmm	8GA45-067h-h080klmm	8GA45-067h-h100klmm
<b>Gearbox</b>						
Number of gear stages	2		3	2	3	2
Gear ratio i	32	40	60	64	80	100
Nominal output torque $T_{2N}$ [Nm]	44	40	44	18	44	15
Max. output torque $T_{2max}$ [Nm]	70	64	70	29	70	24
Emergency switch-off torque $T_{2stop}$ [Nm]	88	80	88	80	88	80
Idle torque [Nm] at 20°C and 3000 rpm	0.2					
Max. average drive speed $n_{1N50\%}$ [rpm] at 50% $T_{2N}$ and S1	4500					
Max. average drive speed $n_{1N100\%}$ [rpm] at 100% $T_{2N}$ and S1	4500					
Max. drive speed $n_{1max}$ [rpm]	13000					
Max. backlash $J_i$ [arcmin]	18		21	18	21	18
Reduced backlash $J_i$ [arcmin] less than	0					
Torsional rigidity $C_{t21}$ [Nm/arcmin]	2.5					
Tilting rigidity $C_{2K}$ [Nm/arcmin]	0					
Max. breakdown torque $M_{2Kmax}$ [Nm]	0					
Max. radial force $F_{rmax}$ [N] for 30,000 h	700					
Max. radial force $F_{rmax}$ [N] for 20,000 h	900					
Max. axial force $F_{amax}$ [N] for 30,000 h	800					
Max. axial force $F_{amax}$ [N] for 20,000 h	1000					
Operating noise $L_{PA}$ [dB(A)]	70					
Efficiency at full load $\eta$ [%]	92		88	92	88	92
Min. operating temperature $B_{Tempmin}$ [°C]	-25					
Max. operating temperature $B_{Tempmax}$ [°C]	90					
Mounting orientation	Any					
Degree of protection	IP54					
Weight m [kg]	2.1		2.3	2.1	2.3	2.1
Moment of inertia $J_1$ [kgcm <sup>2</sup> ]	0.175		0.187	0.175	0.186	0.175

## 4.4.8.17 8GA45, gearbox size 089 - Technical data

## Gear ratio 003 to 009

Order number	8GA45-089h-h003klmm	8GA45-089h-h004klmm	8GA45-089h-h005klmm	8GA45-089h-h007klmm	8GA45-089h-h008klmm	8GA45-089h-h009klmm
<b>Gearbox</b>						
Number of gear stages	1			-	1	2
Gear ratio i	3	4	5	7	8	9
Nominal output torque $T_{2N}$ [Nm]	40	53	67	65.0	50	130
Max. output torque $T_{2max}$ [Nm]	64	85	107	104.0	80	208
Emergency switch-off torque $T_{2stop}$ [Nm]	180	240	220	178	190	260
Idle torque [Nm] at 20°C and 3000 rpm	0.85	0.75	0.65	0.55		0.6
Max. average drive speed $n_{1N50\%}$ [rpm] at 50% $T_{2N}$ and S1	3100	3250	3350	4000		3150
Max. average drive speed $n_{1N100\%}$ [rpm] at 100% $T_{2N}$ and S1	2300		2350	3000	3650	2050
Max. drive speed $n_{1max}$ [rpm]	7000					
Max. backlash $J_i$ [arcmin]	13					15
Reduced backlash $J_i$ [arcmin] less than	0			0	0	
Torsional rigidity $C_{t21}$ [Nm/arcmin]	4.5					6.5
Tilting rigidity $C_{2K}$ [Nm/arcmin]	0			0.0	0	
Max. breakdown torque $M_{2Kmax}$ [Nm]	0			0.0	0	
Max. radial force $F_{rmax}$ [N] for 30,000 h	1700					
Max. radial force $F_{rmax}$ [N] for 20,000 h	2050					
Max. axial force $F_{amax}$ [N] for 30,000 h	2000					
Max. axial force $F_{amax}$ [N] for 20,000 h	2500					
Operating noise $L_{PA}$ [dB(A)]	73					
Efficiency at full load $\eta$ [%]	94					92
Min. operating temperature $B_{Tempmin}$ [°C]	-25					
Max. operating temperature $B_{Tempmax}$ [°C]	90					
Mounting orientation	Any			-	Any	
Degree of protection	IP54			-	IP54	
Weight m [kg]	5.5			5.50	5.5	6.1
Moment of inertia $J_1$ [kgcm <sup>2</sup> ]	1.189	0.939	0.869	0.839	0.809	1.159

## Gear ratio 010 to 025

Order number	8GA45-089h-h010klmm	8GA45-089h-h012klmm	8GA45-089h-h015klmm	8GA45-089h-h016klmm	8GA45-089h-h020klmm	8GA45-089h-h025klmm	
<b>Gearbox</b>							
Number of gear stages	1	2					
Gear ratio i	10	12	15	16	20	25	
Nominal output torque $T_{2N}$ [Nm]	38	120	110	120		110	
Max. output torque $T_{2max}$ [Nm]	61	192	176	192		176	
Emergency switch-off torque $T_{2stop}$ [Nm]	170	240	220	240		220	
Idle torque [Nm] at 20°C and 3000 rpm	0.5	0.55			0.5		
Max. average drive speed $n_{1N50\%}$ [rpm] at 50% $T_{2N}$ and S1	4000	3750	4000				
Max. average drive speed $n_{1N100\%}$ [rpm] at 100% $T_{2N}$ and S1	4000	2600	3100	3050	3500	4000	
Max. drive speed $n_{1max}$ [rpm]	7000						
Max. backlash $J_t$ [arcmin]	13	15					
Reduced backlash $J_t$ [arcmin] less than	0						
Torsional rigidity $C_{t21}$ [Nm/arcmin]	4.5	6.5					
Tilting rigidity $C_{2K}$ [Nm/arcmin]	0						
Max. breakdown torque $M_{2Kmax}$ [Nm]	0						
Max. radial force $F_{rmax}$ [N] for 30,000 h				1700			
Max. radial force $F_{rmax}$ [N] for 20,000 h				2050			
Max. axial force $F_{amax}$ [N] for 30,000 h				2000			
Max. axial force $F_{amax}$ [N] for 20,000 h				2500			
Operating noise $L_{pA}$ [dB(A)]				73			
Efficiency at full load $\eta$ [%]	94	92					
Min. operating temperature $B_{Tempmin}$ [°C]				-25			
Max. operating temperature $B_{Tempmax}$ [°C]				90			
Mounting orientation				Any			
Degree of protection	IP54						
Weight m [kg]	5.5	6.1					
Moment of inertia $J_1$ [kgcm <sup>2</sup> ]	0.809	1.139	1.129	0.919	0.859		

## Gear ratio 032 to 100

Order number	8GA45-089h- h032klmm	8GA45-089h- h040klmm	8GA45-089h- h060klmm	8GA45-089h- h064klmm	8GA45-089h- h080klmm	8GA45-089h- h100klmm
<b>Gearbox</b>						
Number of gear stages	2		3	2	3	2
Gear ratio i	32	40	60	64	80	100
Nominal output torque $T_{2N}$ [Nm]	120	110		50	120	38
Max. output torque $T_{2max}$ [Nm]	192	176		80	192	61
Emergency switch-off torque $T_{2stop}$ [Nm]	240	220		190	240	170
Idle torque [Nm] at 20°C and 3000 rpm	0.45		0.5	0.45	0.5	0.45
Max. average drive speed $n_{1N50\%}$ [rpm] at 50% $T_{2N}$ and S1	4000					
Max. average drive speed $n_{1N100\%}$ [rpm] at 100% $T_{2N}$ and S1	4000					
Max. drive speed $n_{1max}$ [rpm]	7000					
Max. backlash $J_i$ [arcmin]	15		17	15	17	15
Reduced backlash $J_i$ [arcmin] less than	0					
Torsional rigidity $C_{t21}$ [Nm/arcmin]	6.5		6.3	6.5	6.3	6.5
Tilting rigidity $C_{2K}$ [Nm/arcmin]	0					
Max. breakdown torque $M_{2Kmax}$ [Nm]	0					
Max. radial force $F_{rmax}$ [N] for 30,000 h	1700					
Max. radial force $F_{rmax}$ [N] for 20,000 h	2050					
Max. axial force $F_{amax}$ [N] for 30,000 h	2000					
Max. axial force $F_{amax}$ [N] for 20,000 h	2500					
Operating noise $L_{PA}$ [dB(A)]	73					
Efficiency at full load $\eta$ [%]	92		88	92	88	92
Min. operating temperature $B_{Tempmin}$ [°C]	-25					
Max. operating temperature $B_{Tempmax}$ [°C]	90					
Mounting orientation	Any					
Degree of protection	IP54					
Weight m [kg]	6.1		6.6	6.1	6.6	6.1
Moment of inertia $J_1$ [kgcm <sup>2</sup> ]	0.809		0.929	0.809	0.919	0.809

## 4.4.8.18 8GA50, gearbox size 070 - Technical data

## Gear ratio 003 to 009

Order number	8GA50-070h-h003klmm	8GA50-070h-h004klmm	8GA50-070h-h005klmm	8GA50-070h-h007klmm	8GA50-070h-h008klmm	8GA50-070h-h009klmm
<b>Gearbox</b>						
Number of gear stages	1			-	1	2
Gear ratio i	3	4	5	7	8	9
Nominal output torque $T_{2N}$ [Nm]	14	19	24	25.0	18	33
Max. output torque $T_{2max}$ [Nm]	22	30	38	40.0	29	53
Emergency switch-off torque $T_{2stop}$ [Nm]	66	86	80		88	
Idle torque [Nm] at 20°C and 3000 rpm	0.5	0.4	0.35	0.30	0.25	
Max. average drive speed $n_{1N50\%}$ [rpm] at 50% $T_{2N}$ and S1	4200	4500				
Max. average drive speed $n_{1N100\%}$ [rpm] at 100% $T_{2N}$ and S1	3300	3500	3600	4300	4500	4000
Max. drive speed $n_{1max}$ [rpm]	13000					
Max. backlash $J_i$ [arcmin]	16					18
Reduced backlash $J_i$ [arcmin] less than	0			0	0	
Torsional rigidity $C_{t21}$ [Nm/arcmin]	1.5					2.5
Tilting rigidity $C_{2K}$ [Nm/arcmin]	0			0.0	0	
Max. breakdown torque $M_{2Kmax}$ [Nm]	0			0.0	0	
Max. radial force $F_{rmax}$ [N] for 30,000 h	900					
Max. radial force $F_{rmax}$ [N] for 20,000 h	1050					
Max. axial force $F_{amax}$ [N] for 30,000 h	1000					
Max. axial force $F_{amax}$ [N] for 20,000 h	1350					
Operating noise $L_{PA}$ [dB(A)]	70					
Efficiency at full load $\eta$ [%]	94					92
Min. operating temperature $B_{Tempmin}$ [°C]	-25					
Max. operating temperature $B_{Tempmax}$ [°C]	90					
Mounting orientation	Any			-	Any	
Degree of protection	IP54			-	IP54	
Weight m [kg]	2.3		2.30		2.3	2.6
Moment of inertia $J_1$ [kgcm <sup>2</sup> ]	0.157	0.106	0.086	0.077	0.068	0.133

## Gear ratio 010 to 025

Order number	8GA50-070h-h010klmm	8GA50-070h-h012klmm	8GA50-070h-h015klmm	8GA50-070h-h016klmm	8GA50-070h-h020klmm	8GA50-070h-h025klmm
<b>Gearbox</b>						
Number of gear stages	1	2				
Gear ratio i	10	12	15	16	20	25
Nominal output torque $T_{2N}$ [Nm]	15	33				30
Max. output torque $T_{2max}$ [Nm]	24	53				48
Emergency switch-off torque $T_{2stop}$ [Nm]	70	88				80
Idle torque [Nm] at 20°C and 3000 rpm	0.25				0.2	
Max. average drive speed $n_{1N50\%}$ [rpm] at 50% $T_{2N}$ and S1	4500					
Max. average drive speed $n_{1N100\%}$ [rpm] at 100% $T_{2N}$ and S1	4500					
Max. drive speed $n_{1max}$ [rpm]	13000					
Max. backlash $J_t$ [arcmin]	16	18				
Reduced backlash $J_t$ [arcmin] less than	0					
Torsional rigidity $C_{t21}$ [Nm/arcmin]	1.5	2.5				
Tilting rigidity $C_{2K}$ [Nm/arcmin]	0					
Max. breakdown torque $M_{2Kmax}$ [Nm]	0					
Max. radial force $F_{rmax}$ [N] for 30,000 h	900					
Max. radial force $F_{rmax}$ [N] for 20,000 h	1050					
Max. axial force $F_{amax}$ [N] for 30,000 h	1000					
Max. axial force $F_{amax}$ [N] for 20,000 h	1350					
Operating noise $L_{PA}$ [dB(A)]	70					
Efficiency at full load $\eta$ [%]	94	92				
Min. operating temperature $B_{Tempmin}$ [°C]	-25					
Max. operating temperature $B_{Tempmax}$ [°C]	90					
Mounting orientation	Any					
Degree of protection	IP54					
Weight m [kg]	2.3	2.6				
Moment of inertia $J_1$ [kgcm <sup>2</sup> ]	0.066	0.128	0.078	0.089	0.076	0.075

**Gear ratio 032 to 100**

Order number	8GA50-070hh032klmm	8GA50-070hh040klmm	8GA50-070hh064klmm	8GA50-070hh100klmm
<b>Gearbox</b>				
Number of gear stages	2			
Gear ratio $i$	32	40	64	100
Nominal output torque $T_{2N}$ [Nm]	33	30	18	15
Max. output torque $T_{2max}$ [Nm]	53	48	29	24
Emergency switch-off torque $T_{2stop}$ [Nm]	88	80		
Idle torque [Nm] at 20°C and 3000 rpm	0.2			
Max. average drive speed $n_{1N50\%}$ [rpm] at 50% $T_{2N}$ and S1	4500			
Max. average drive speed $n_{1N100\%}$ [rpm] at 100% $T_{2N}$ and S1	4500			
Max. drive speed $n_{1max}$ [rpm]	13000			
Max. backlash $J_i$ [arcmin]	18			
Reduced backlash $J_i$ [arcmin] less than	0			
Torsional rigidity $C_{t21}$ [Nm/arcmin]	2.5			
Tilting rigidity $C_{2K}$ [Nm/arcmin]	0			
Max. breakdown torque $M_{2Kmax}$ [Nm]	0			
Max. radial force $F_{rmax}$ [N] for 30,000 h	900			
Max. radial force $F_{rmax}$ [N] for 20,000 h	1050			
Max. axial force $F_{amax}$ [N] for 30,000 h	1000			
Max. axial force $F_{amax}$ [N] for 20,000 h	1350			
Operating noise $L_{pA}$ [dB(A)]	70			
Efficiency at full load $\eta$ [%]	92			
Min. operating temperature $B_{Tempmin}$ [°C]	-25			
Max. operating temperature $B_{Tempmax}$ [°C]	90			
Mounting orientation	Any			
Degree of protection	IP54			
Weight $m$ [kg]	2.6			
Moment of inertia $J_1$ [kgcm <sup>2</sup> ]	0.064			

## 4.4.8.19 8GA50, gearbox size 090 - Technical data

## Gear ratio 003 to 009

Order number	8GA50-090h-h003klmm	8GA50-090h-h004klmm	8GA50-090h-h005klmm	8GA50-090h-h007klmm	8GA50-090h-h008klmm	8GA50-090h-h009klmm
<b>Gearbox</b>						
Number of gear stages	1			-	1	2
Gear ratio i	3	4	5	7	8	9
Nominal output torque $T_{2N}$ [Nm]	40	53	67	65.0	50	97
Max. output torque $T_{2max}$ [Nm]	64	85	107	104.0	80	155
Emergency switch-off torque $T_{2stop}$ [Nm]	180	240	220	178	190	260
Idle torque [Nm] at 20°C and 3000 rpm	1.05	0.85	0.75	0.60	0.6	
Max. average drive speed $n_{1N50\%}$ [rpm] at 50% $T_{2N}$ and S1	3000	3150	3250	3950	4000	3500
Max. average drive speed $n_{1N100\%}$ [rpm] at 100% $T_{2N}$ and S1	2200	2250	2300	2900	3550	2450
Max. drive speed $n_{1max}$ [rpm]	7000					
Max. backlash $J_i$ [arcmin]	13					15
Reduced backlash $J_i$ [arcmin] less than	0			0	0	
Torsional rigidity $C_{t21}$ [Nm/arcmin]	4.5					6.5
Tilting rigidity $C_{2K}$ [Nm/arcmin]	0			0.0	0	
Max. breakdown torque $M_{2Kmax}$ [Nm]	0			0.0	0	
Max. radial force $F_{rmax}$ [N] for 30,000 h	1700					
Max. radial force $F_{rmax}$ [N] for 20,000 h	1900					
Max. axial force $F_{amax}$ [N] for 30,000 h	1500					
Max. axial force $F_{amax}$ [N] for 20,000 h	2000					
Operating noise $L_{PA}$ [dB(A)]	73					
Efficiency at full load $\eta$ [%]	94					92
Min. operating temperature $B_{Tempmin}$ [°C]	-25					
Max. operating temperature $B_{Tempmax}$ [°C]	90					
Mounting orientation	Any			-	Any	
Degree of protection	IP54			-	IP54	
Weight m [kg]	5.3			5.30	5.3	6.1
Moment of inertia $J_1$ [kgcm <sup>2</sup> ]	0.82	0.57	0.48	0.440	0.4	0.75

## Gear ratio 010 to 025

Order number	8GA50-090h-h010klmm	8GA50-090h-h012klmm	8GA50-090h-h015klmm	8GA50-090h-h016klmm	8GA50-090h-h020klmm	8GA50-090h-h025klmm
<b>Gearbox</b>						
Number of gear stages	1		2			
Gear ratio i	10	12	15	16	20	25
Nominal output torque $T_{2N}$ [Nm]	38	90	82	90		82
Max. output torque $T_{2max}$ [Nm]	61	144	131	144		131
Emergency switch-off torque $T_{2stop}$ [Nm]	170	240	220	240		220
Idle torque [Nm] at 20°C and 3000 rpm	0.55			0.5		
Max. average drive speed $n_{1N50\%}$ [rpm] at 50% $T_{2N}$ and S1	4000					
Max. average drive speed $n_{1N100\%}$ [rpm] at 100% $T_{2N}$ and S1	4000	3000	3500	3450	3900	4000
Max. drive speed $n_{1max}$ [rpm]	7000					
Max. backlash $J_t$ [arcmin]	13	15				
Reduced backlash $J_t$ [arcmin] less than	0					
Torsional rigidity $C_{t21}$ [Nm/arcmin]	4.5	6.5				
Tilting rigidity $C_{2K}$ [Nm/arcmin]	0					
Max. breakdown torque $M_{2Kmax}$ [Nm]	0					
Max. radial force $F_{rmax}$ [N] for 30,000 h				1700		
Max. radial force $F_{rmax}$ [N] for 20,000 h				1900		
Max. axial force $F_{amax}$ [N] for 30,000 h				1500		
Max. axial force $F_{amax}$ [N] for 20,000 h				2000		
Operating noise $L_{PA}$ [dB(A)]				73		
Efficiency at full load $\eta$ [%]	94	92				
Min. operating temperature $B_{Tempmin}$ [°C]	-25					
Max. operating temperature $B_{Tempmax}$ [°C]	90					
Mounting orientation	Any					
Degree of protection	IP54					
Weight m [kg]	5.3	6.1				
Moment of inertia $J_1$ [kgcm <sup>2</sup> ]	0.4	0.73	0.71	0.5	0.44	

**Gear ratio 032 to 100**

Order number	8GA50-090hh032klmm	8GA50-090hh040klmm	8GA50-090hh064klmm	8GA50-090hh100klmm
<b>Gearbox</b>				
Number of gear stages	2			
Gear ratio $i$	32	40	64	100
Nominal output torque $T_{2N}$ [Nm]	90	82	50	38
Max. output torque $T_{2max}$ [Nm]	144	131	80	61
Emergency switch-off torque $T_{2stop}$ [Nm]	240	220	190	170
Idle torque [Nm] at 20°C and 3000 rpm	0.5	0.45		
Max. average drive speed $n_{1N50\%}$ [rpm] at 50% $T_{2N}$ and S1	4000			
Max. average drive speed $n_{1N100\%}$ [rpm] at 100% $T_{2N}$ and S1	4000			
Max. drive speed $n_{1max}$ [rpm]	7000			
Max. backlash $J_i$ [arcmin]	15			
Reduced backlash $J_i$ [arcmin] less than	0			
Torsional rigidity $C_{i21}$ [Nm/arcmin]	6.5			
Tilting rigidity $C_{2K}$ [Nm/arcmin]	0			
Max. breakdown torque $M_{2Kmax}$ [Nm]	0			
Max. radial force $F_{rmax}$ [N] for 30,000 h	1700			
Max. radial force $F_{rmax}$ [N] for 20,000 h	1900			
Max. axial force $F_{amax}$ [N] for 30,000 h	1500			
Max. axial force $F_{amax}$ [N] for 20,000 h	2000			
Operating noise $L_{pA}$ [dB(A)]	73			
Efficiency at full load $\eta$ [%]	92			
Min. operating temperature $B_{Tempmin}$ [°C]	-25			
Max. operating temperature $B_{Tempmax}$ [°C]	90			
Mounting orientation	Any			
Degree of protection	IP54			
Weight $m$ [kg]	6.1			
Moment of inertia $J_1$ [kgcm <sup>2</sup> ]	0.39			

## 4.4.8.20 8GA55, gearbox size 064 - Technical data

## Gear ratio 003 to 009

Order number	8GA55-064h-h003klmm	8GA55-064h-h004klmm	8GA55-064h-h005klmm	8GA55-064h-h007klmm	8GA55-064h-h008klmm	8GA55-064h-h009klmm
<b>Gearbox</b>						
Number of gear stages	1					2
Gear ratio $i$	3	4	5	7	8	9
Nominal output torque $T_{2N}$ [Nm]	14	19	24	25	18	44
Max. output torque $T_{2max}$ [Nm]	22	30	38	40	29	70
Emergency switch-off torque $T_{2stop}$ [Nm]	66	86	80			88
Idle torque [Nm] at 20°C and 3000 rpm	0.3	0.25	0.15	0.1	0.4	0.15
Max. average drive speed $n_{1N50\%}$ [rpm] at 50% $T_{2N}$ and S1	4000	4400	4500			4300
Max. average drive speed $n_{1N100\%}$ [rpm] at 100% $T_{2N}$ and S1	3300	3500	3700	4400	4500	3200
Max. drive speed $n_{1max}$ [rpm]	13000					
Max. backlash $J_1$ [arcmin]	16					18
Torsional rigidity $C_{t21}$ [Nm/arcmin]	11.6	11.9	11.3	10.7	9.8	11.6
Max. radial force $F_{rmax}$ [N] for 30,000 h	500					
Max. radial force $F_{rmax}$ [N] for 20,000 h	550					
Max. axial force $F_{amax}$ [N] for 30,000 h	1200					
Max. axial force $F_{amax}$ [N] for 20,000 h	1200					
Operating noise $L_{PA}$ [dB(A)]	70					
Efficiency at full load $\eta$ [%]	93		92		91	92
Min. operating temperature $B_{Tempmin}$ [°C]	-25					
Max. operating temperature $B_{Tempmax}$ [°C]	90					
Mounting orientation	Any					
Degree of protection	IP54					
Weight $m$ [kg]	1.4					2.3
Moment of inertia $J_1$ [kgcm <sup>2</sup> ]	0.439	0.294	0.265	0.24	0.235	0.359

**Gear ratio 010 to 025**

Order number	8GA55-064h-h010klmm	8GA55-064h-h012klmm	8GA55-064h-h015klmm	8GA55-064h-h016klmm	8GA55-064h-h020klmm	8GA55-064h-h025klmm
<b>Gearbox</b>						
Number of gear stages	1	2				
Gear ratio i	10	12	15	16	20	25
Nominal output torque $T_{2N}$ [Nm]	15	44				40
Max. output torque $T_{2max}$ [Nm]	24	70				64
Emergency switch-off torque $T_{2stop}$ [Nm]	70	88				80
Idle torque [Nm] at 20°C and 3000 rpm	0.15	0.2	0.4	0.2	0.1	0.35
Max. average drive speed $n_{1N50\%}$ [rpm] at 50% $T_{2N}$ and S1	4500					
Max. average drive speed $n_{1N100\%}$ [rpm] at 100% $T_{2N}$ and S1	4500	3700	4300	4400	4500	
Max. drive speed $n_{1max}$ [rpm]	13000					
Max. backlash $J_i$ [arcmin]	16	18				
Torsional rigidity $C_{t21}$ [Nm/arcmin]	8.9	11.6	11.9			11.3
Max. radial force $F_{rmax}$ [N] for 30,000 h	500					
Max. radial force $F_{rmax}$ [N] for 20,000 h	550					
Max. axial force $F_{amax}$ [N] for 30,000 h	1200					
Max. axial force $F_{amax}$ [N] for 20,000 h	1200					
Operating noise $L_{PA}$ [dB(A)]	70					
Efficiency at full load $\eta$ [%]	90	92	91		90	89
Min. operating temperature $B_{Tempmin}$ [°C]	-25					
Max. operating temperature $B_{Tempmax}$ [°C]	90					
Mounting orientation	Any					
Degree of protection	IP54					
Weight m [kg]	1.4	2.3				
Moment of inertia $J_1$ [kgcm <sup>2</sup> ]	0.228	0.352	0.235	0.244	0.233	0.232

**Gear ratio 032 to 100**

Order number	8GA55-064hh032klmm	8GA55-064hh040klmm	8GA55-064hh064klmm	8GA55-064hh100klmm
<b>Gearbox</b>				
Number of gear stages	2			
Gear ratio $i$	32	40	64	100
Nominal output torque $T_{2N}$ [Nm]	44	40	18	15
Max. output torque $T_{2max}$ [Nm]	70	64	29	24
Emergency switch-off torque $T_{2stop}$ [Nm]	88	80		
Idle torque [Nm] at 20°C and 3000 rpm	0.1	0.35		
Max. average drive speed $n_{1N50\%}$ [rpm] at 50% $T_{2N}$ and S1	4500			
Max. average drive speed $n_{1N100\%}$ [rpm] at 100% $T_{2N}$ and S1	4500			
Max. drive speed $n_{1max}$ [rpm]	13000			
Max. backlash $J$ , [arcmin]	18			
Torsional rigidity $C_{i21}$ [Nm/arcmin]	10.5	10.1	9.6	9.1
Max. radial force $F_{rmax}$ [N] for 30,000 h	500			
Max. radial force $F_{rmax}$ [N] for 20,000 h	550			
Max. axial force $F_{amax}$ [N] for 30,000 h	1200			
Max. axial force $F_{amax}$ [N] for 20,000 h	1200			
Operating noise $L_{PA}$ [dB(A)]	70			
Efficiency at full load $\eta$ [%]	89	87	75	64
Min. operating temperature $B_{Tempmin}$ [°C]	-25			
Max. operating temperature $B_{Tempmax}$ [°C]	90			
Mounting orientation	Any			
Degree of protection	IP54			
Weight $m$ [kg]	2.3			
Moment of inertia $J_1$ [kgcm <sup>2</sup> ]	0.223	0.222		0.22

## 4.4.8.21 8GA60, gearbox size 070 - Technical data

## Gear ratio 004 to 020

Order number	8GA60-070h-h004klmm	8GA60-070h-h005klmm	8GA60-070h-h008klmm	8GA60-070h-h010klmm	8GA60-070h-h016klmm	8GA60-070h-h020klmm
<b>Gearbox</b>						
Number of gear stages	1			2		
Gear ratio i	4	5	8	10	16	20
Nominal output torque $T_{2N}$ [Nm]	45	42	27	22	77	
Max. output torque $T_{2max}$ [Nm]	72	67	43	35	123	
Emergency switch-off torque $T_{2stop}$ [Nm]	100		75		150	
Idle torque [Nm] at 20°C and 3000 rpm	1.5	1.35	1.25	1.2	1	0.9
Max. average drive speed $n_{1N50\%}$ [rpm] at 50% $T_{2N}$ and S1	1800	2000	2350	2500	1850	2000
Max. average drive speed $n_{1N100\%}$ [rpm] at 100% $T_{2N}$ and S1	1450	1650	2100	2300	1550	1700
Max. drive speed $n_{1max}$ [rpm]	16000					
Max. backlash $J_1$ [arcmin]	5				7	
Reduced backlash $J_1$ [arcmin] less than	0					
Torsional rigidity $C_{21}$ [Nm/arcmin]	2.4					
Tilting rigidity $C_{2K}$ [Nm/arcmin]	0					
Max. breakdown torque $M_{2Kmax}$ [Nm]	0					
Max. radial force $F_{rmax}$ [N] for 30,000 h	3200					
Max. radial force $F_{rmax}$ [N] for 20,000 h	3200					
Max. axial force $F_{amax}$ [N] for 30,000 h	3700			3900		
Max. axial force $F_{amax}$ [N] for 20,000 h	4300			4400		
Operating noise $L_{PA}$ [dB(A)]	66			94		
Efficiency at full load $\eta$ [%]	96			94		
Min. operating temperature $B_{Tempmin}$ [°C]	-25					
Max. operating temperature $B_{Tempmax}$ [°C]	90					
Mounting orientation	Any					
Degree of protection	IP 65					
Weight m [kg]	3			3.9		
Moment of inertia $J_1$ [kgcm <sup>2</sup> ]	0.654	0.6	0.532	0.516	0.639	0.591

## Gear ratio 025 to 100

Order number	8GA60-070h- h025klmm	8GA60-070h- h032klmm	8GA60-070h- h040klmm	8GA60-070h- h050klmm	8GA60-070h- h064klmm	8GA60-070h- h100klmm
<b>Gearbox</b>						
Number of gear stages	2					
Gear ratio i	25	32	40	50	64	100
Nominal output torque $T_{2N}$ [Nm]	65	77	65		40	27
Max. output torque $T_{2max}$ [Nm]	104	123	104		64	43
Emergency switch-off torque $T_{2stop}$ [Nm]	150				80	
Idle torque [Nm] at 20°C and 3000 rpm	0.9	0.8		0.75	0.8	0.75
Max. average drive speed $n_{1N50\%}$ [rpm] at 50% $T_{2N}$ and S1	2150	2300	2400	2500	2600	2700
Max. average drive speed $n_{1N100\%}$ [rpm] at 100% $T_{2N}$ and S1	1900	2000	2200	2300	2500	2650
Max. drive speed $n_{1max}$ [rpm]	16000					
Max. backlash $J_t$ [arcmin]	7					
Reduced backlash $J_t$ [arcmin] less than	0					
Torsional rigidity $C_{t21}$ [Nm/arcmin]	2.4					
Tilting rigidity $C_{2K}$ [Nm/arcmin]	0					
Max. breakdown torque $M_{2Kmax}$ [Nm]	0					
Max. radial force $F_{rmax}$ [N] for 30,000 h	3200					
Max. radial force $F_{rmax}$ [N] for 20,000 h	3200					
Max. axial force $F_{amax}$ [N] for 30,000 h	3900					
Max. axial force $F_{amax}$ [N] for 20,000 h	4400					
Operating noise $L_{pA}$ [dB(A)]	66					
Efficiency at full load $\eta$ [%]	94					
Min. operating temperature $B_{Tempmin}$ [°C]	-25					
Max. operating temperature $B_{Tempmax}$ [°C]	90					
Mounting orientation	Any					
Degree of protection	IP 65					
Weight m [kg]	3.9					
Moment of inertia $J_1$ [kgcm <sup>2</sup> ]	0.59	0.528			0.514	

## 4.4.9 Dimension diagrams and installation dimensions

### 4.4.9.1 Overview

Motor construction type	Order code	Gearbox	Dimension diagrams <sup>1)</sup>
8D1A2x	8D1A2x.xxx00	Without gearbox	see "8D1A2x" on page 245
8D1B2x	8D1B2x.xxxBD	8GM40 (gearbox size 060)	see "8D1B2x.xxxBD - 8GM40 gearbox (gearbox size 060)" on page 246
	8D1B2x.xxxCF	8GM45 (gearbox size 067)	see "8D1B2x.xxxCF - 8GM45 gearbox (gearbox size 067)" on page 247
	8D1B2x.xxxDG	8GM50 (gearbox size 070)	see "8D1B2x.xxxDG - 8GM50 gearbox (gearbox size 070)" on page 248
	8D1B2x.xxxED	8GM55 (gearbox size 060)	see "8D1B2x.xxxED - 8GM55 gearbox (gearbox size 060)" on page 249
	8D1B2x.xxxHE	8GG40 (gearbox size 064)	see "8D1B2x.xxxHE - 8GG40 gearbox (gearbox size 064)" on page 250
8D1C2x	8D1C2x.xxxxx	With gearbox	Dimension diagrams can only be retrieved in the CAD configurator at <a href="http://cad.br-automation.com">cad.br-automation.com</a> .

1) Dimension diagrams can also be retrieved in the CAD configurator at [cad.br-automation.com](http://cad.br-automation.com).

4.4.9.2 8D1A2x

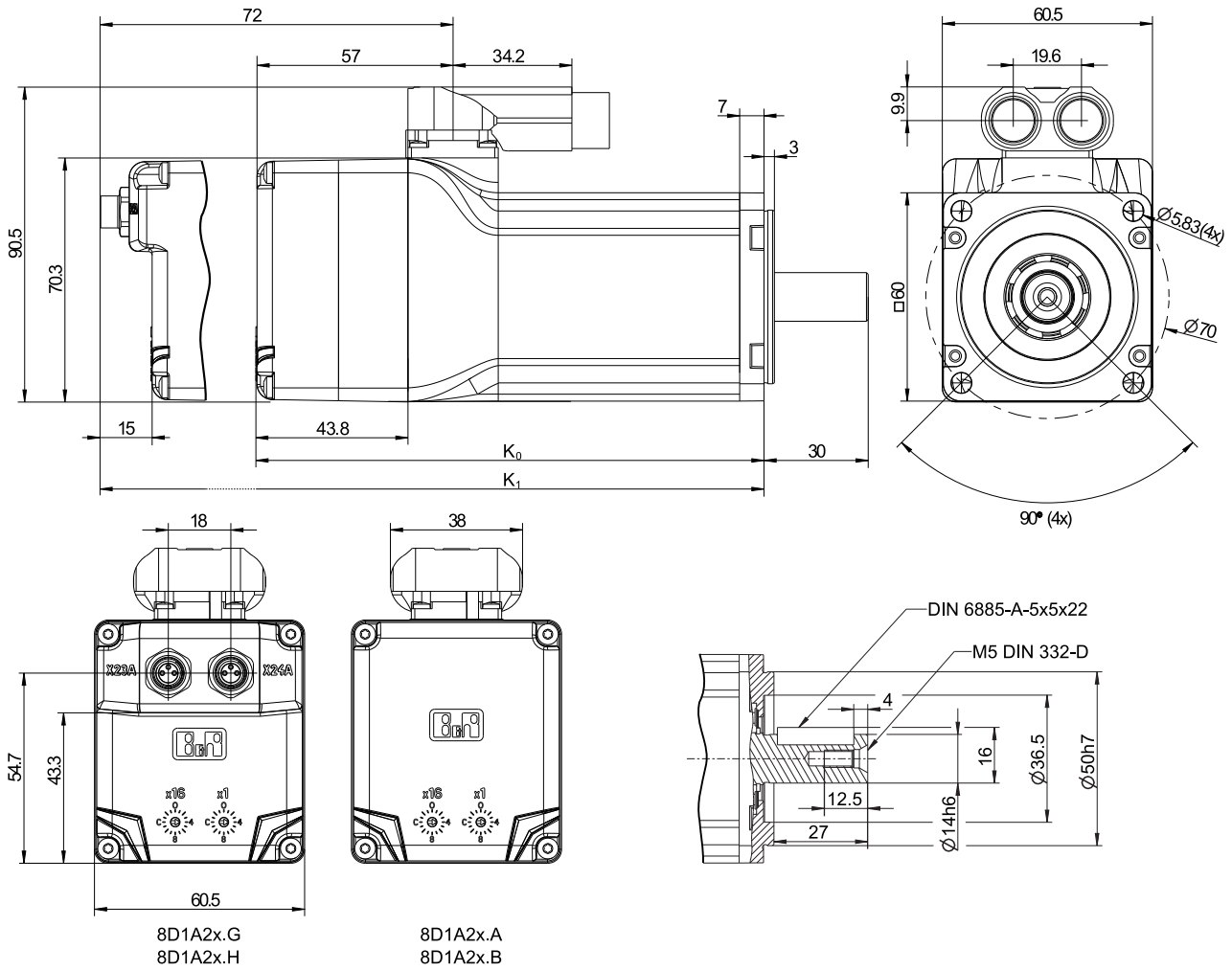

Without electronics option (8D1A2x.A, 8D1A2x.B)

	$K_0$ [mm]	
	Without holding brake	With holding brake
8D1A22	126	159.5
8D1A23	146.5	180

With electronics option (8D1A2x.G, 8D1A2x.H)

	$K_1$ [mm]	
	Without holding brake	With holding brake
8D1A22	141	174.5
8D1A23	161.5	195

4.4.9.3 8D1B2x.xxxBD - 8GM40 gearbox (gearbox size 060)

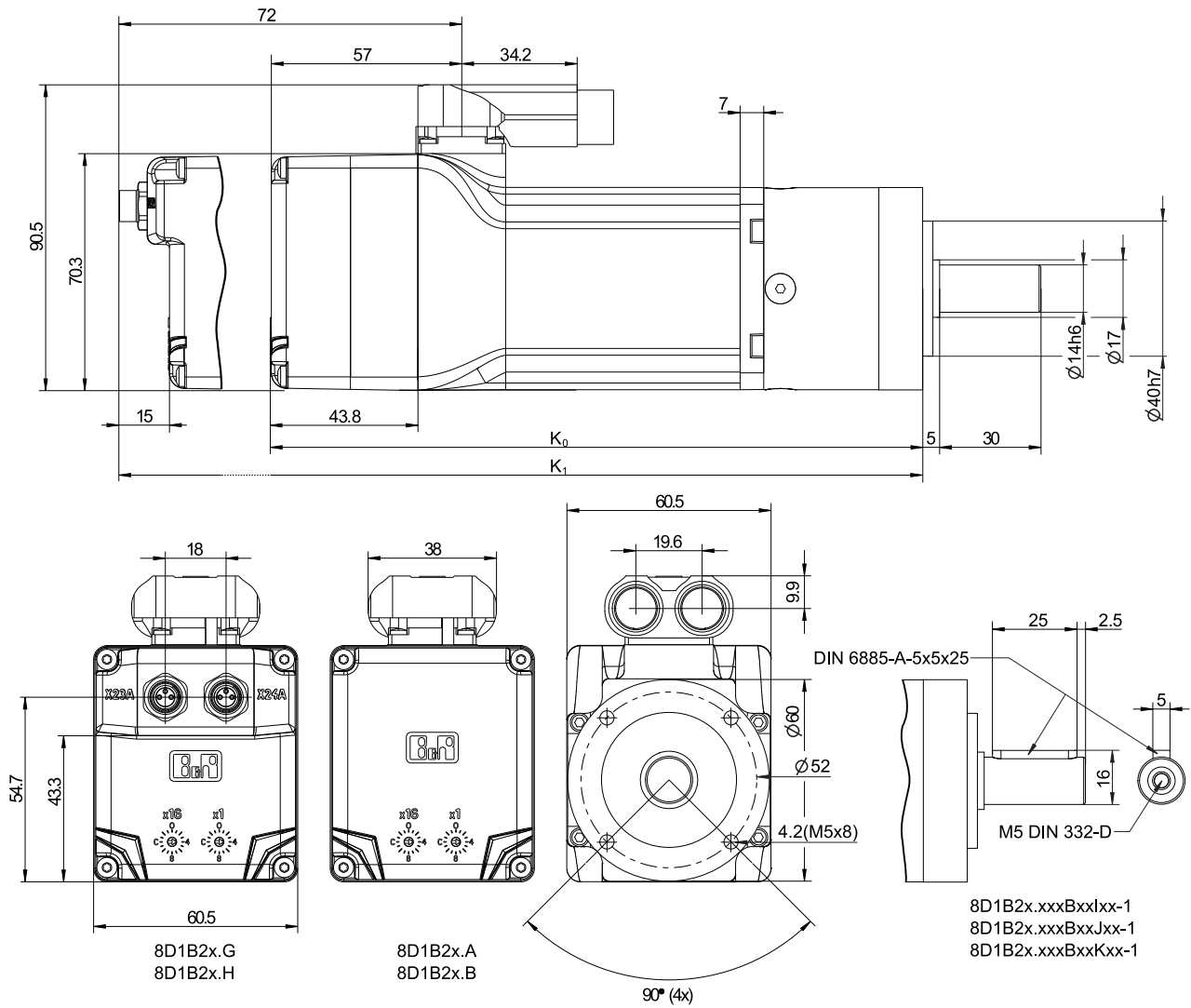

Without electronics option (8D1B2x.A, 8D1B2x.B)

Gearbox motor	$K_0$ [mm]	
	Without holding brake	With holding brake
8D1B22 with 8GM40 1-stage	173	206.5
8D1B22 with 8GM40 2-stage	185.5	219
8D1B23 with 8GM40 1-stage	193.5	227
8D1B23 with 8GM40 2-stage	206	239.5

With electronics option (8D1B2x.G, 8D1B2x.H)

Gearbox motor	$K_1$ [mm]	
	Without holding brake	With holding brake
8D1B22 with 8GM40 1-stage	188	221.5
8D1B22 with 8GM40 2-stage	200.5	234
8D1B23 with 8GM40 1-stage	208.5	242
8D1B23 with 8GM40 2-stage	221	254.5

4.4.9.4 8D1B2x.xxxCF - 8GM45 gearbox (gearbox size 067)

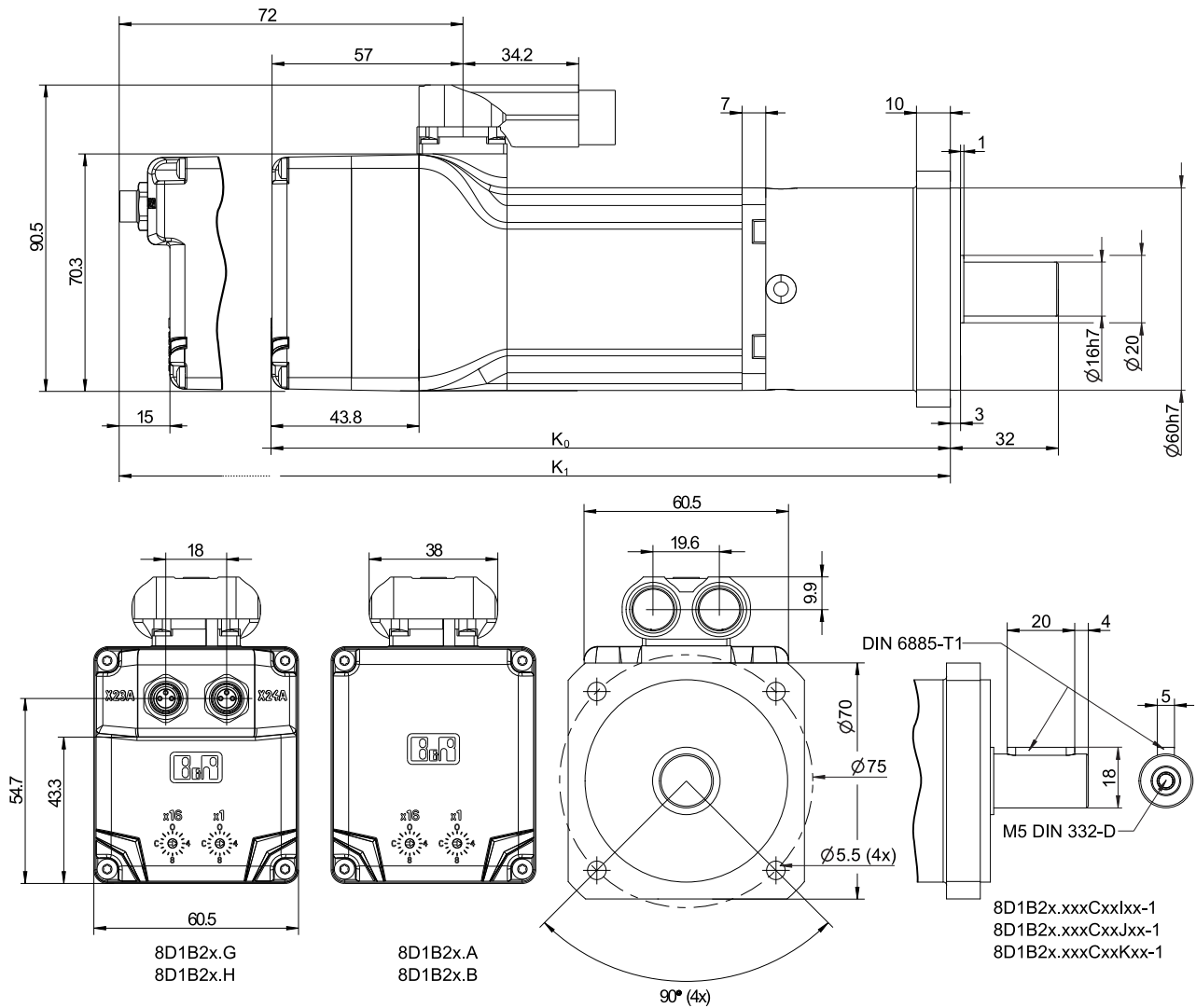

Without electronics option (8D1B2x.A, 8D1B2x.B)

Gearbox motor	$K_0$ [mm]	
	Without holding brake	With holding brake
8D1B22 with 8GM45 1-stage	181	214.5
8D1B22 with 8GM45 2-stage	193.5	227
8D1B23 with 8GM45 1-stage	201.5	235
8D1B23 with 8GM45 2-stage	214	247.5

With electronics option (8D1B2x.G, 8D1B2x.H)

Gearbox motor	$K_1$ [mm]	
	Without holding brake	With holding brake
8D1B22 with 8GM45 1-stage	196	229.5
8D1B22 with 8GM45 2-stage	208.5	242
8D1B23 with 8GM45 1-stage	216.5	250
8D1B23 with 8GM45 2-stage	229	262.5

4.4.9.5 8D1B2x.xxxDG - 8GM50 gearbox (gearbox size 070)

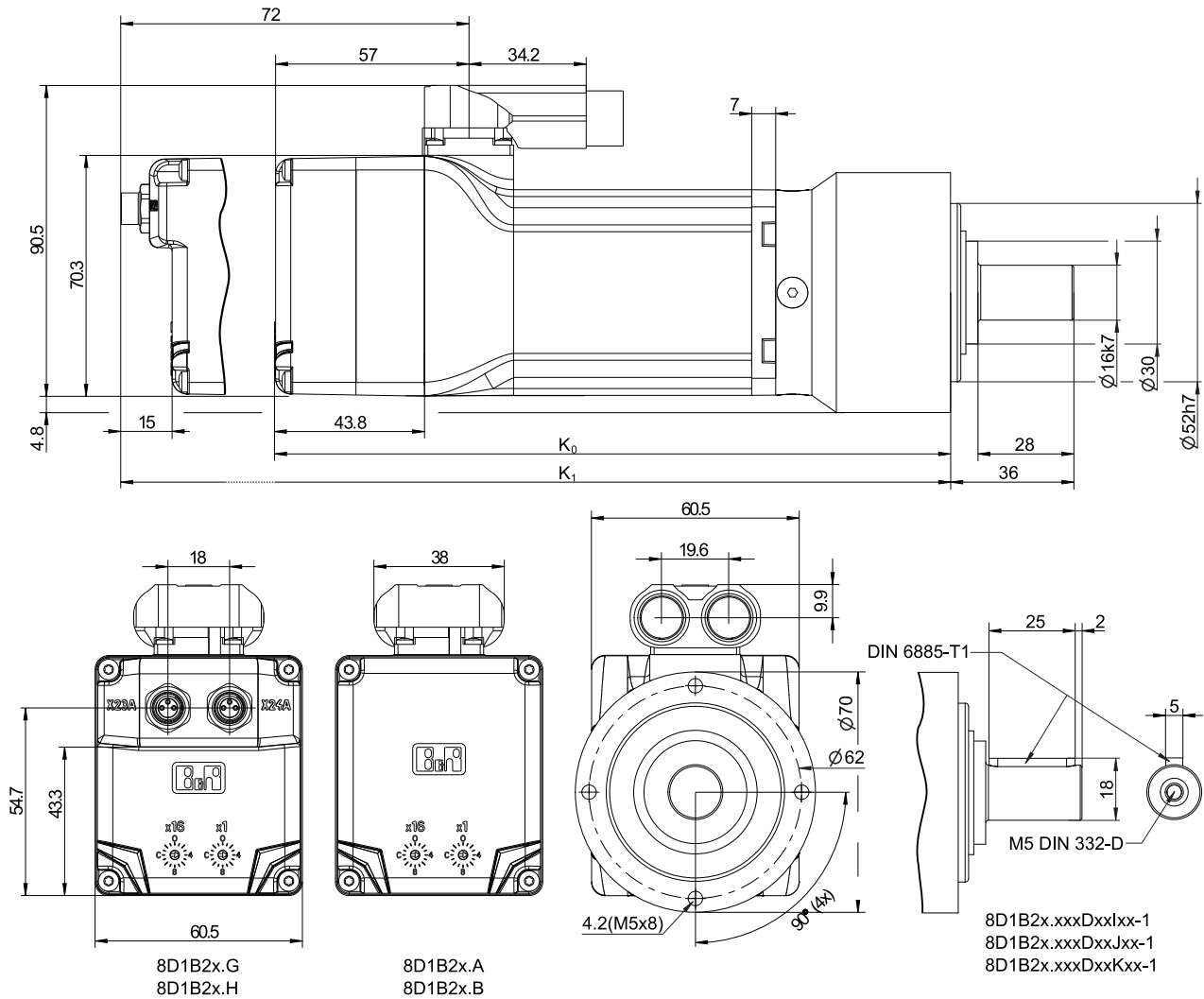

Without electronics option (8D1B2x.A, 8D1B2x.B)

Gearbox motor	K <sub>0</sub> [mm]	
	Without holding brake	With holding brake
8D1B22 with 8GM50 1-stage	177	210.5
8D1B22 with 8GM50 2-stage	190	223.5
8D1B23 with 8GM50 1-stage	197.5	231
8D1B23 with 8GM50 2-stage	210.5	244

With electronics option (8D1B2x.G, 8D1B2x.H)

Gearbox motor	K <sub>1</sub> [mm]	
	Without holding brake	With holding brake
8D1B22 with 8GM50 1-stage	192	225.5
8D1B22 with 8GM50 2-stage	205	238.5
8D1B23 with 8GM50 1-stage	212.5	246
8D1B23 with 8GM50 2-stage	225.5	259

4.4.9.6 8D1B2x.xxxED - 8GM55 gearbox (gearbox size 060)

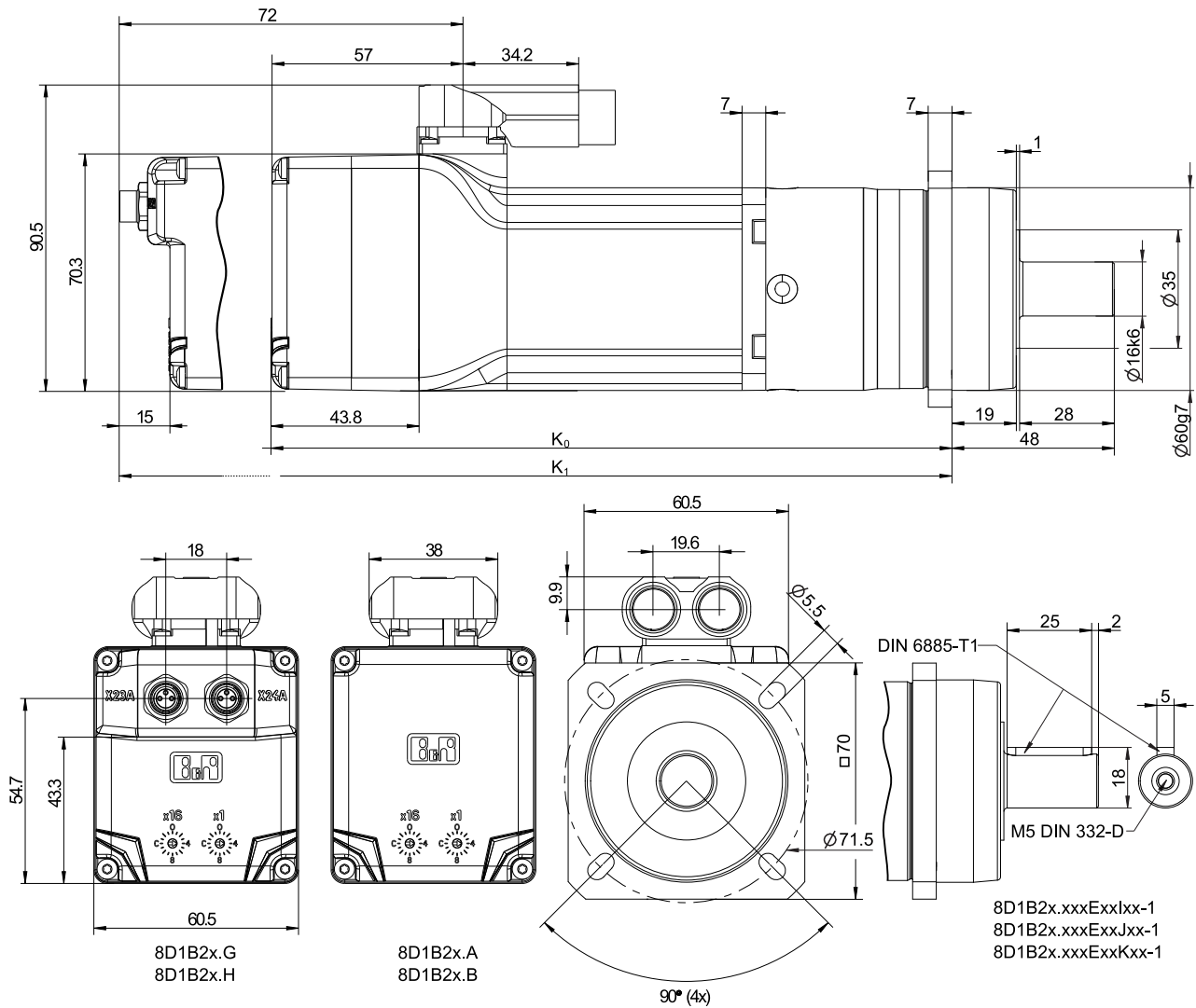

Without electronics option (8D1B2x.A, 8D1B2x.B)

Gearbox motor	$K_0$ [mm]	
	Without holding brake	With holding brake
8D1B22 with 8GM55 1-stage	181	214.5
8D1B22 with 8GM55 2-stage	193.5	227
8D1B23 with 8GM55 1-stage	201.5	235
8D1B23 with 8GM55 2-stage	214	247.5

With electronics option (8D1B2x.G, 8D1B2x.H)

Gearbox motor	$K_1$ [mm]	
	Without holding brake	With holding brake
8D1B22 with 8GM55 1-stage	196	229.5
8D1B22 with 8GM55 2-stage	208.5	242
8D1B23 with 8GM55 1-stage	216.5	250
8D1B23 with 8GM55 2-stage	229	262.5

4.4.9.7 8D1B2x.xxxHE - 8GG40 gearbox (gearbox size 064)

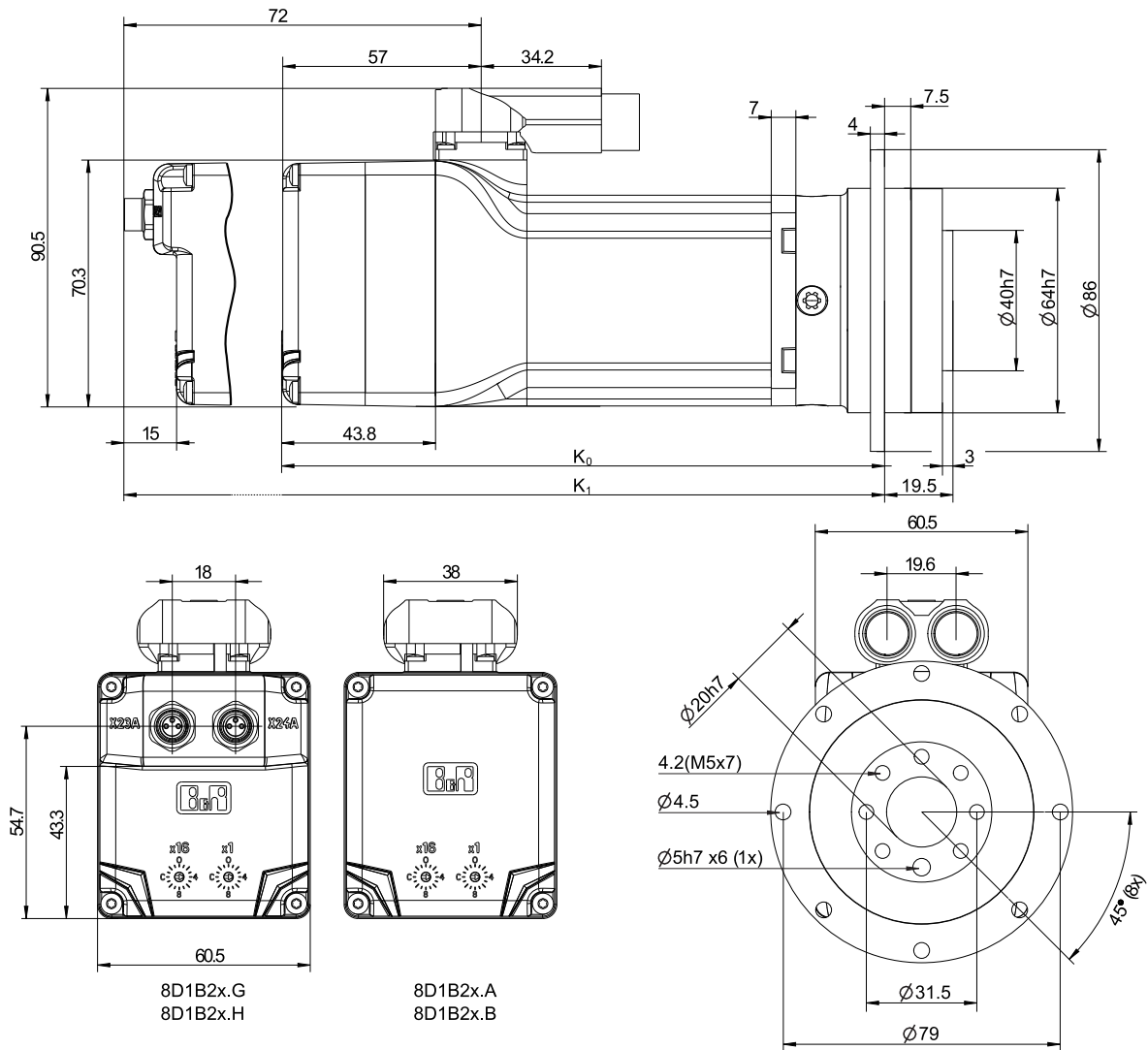

Without electronics option (8D1B2x.A, 8D1B2x.B)

Gearbox motor	K <sub>0</sub> [mm]	
	Without holding brake	With holding brake
8D1B22 with 8GG40 1-stage	151.5	185
8D1B22 with 8GG40 2-stage	164	197.5
8D1B23 with 8GG40 1-stage	172	205.5
8D1B23 with 8GG40 2-stage	184.5	218

With electronics option (8D1B2x.G, 8D1B2x.H)

Gearbox motor	K <sub>1</sub> [mm]	
	Without holding brake	With holding brake
8D1B22 with 8GG40 1-stage	166.5	200
8D1B22 with 8GG40 2-stage	179	212.5
8D1B23 with 8GG40 1-stage	187	220.5
8D1B23 with 8GG40 2-stage	199.5	233

### 4.4.10 Pinouts

#### Danger!

Before performing service work, disconnect the power supply and wait 5 minutes to ensure that the DC bus of the drive system has discharged. Observe regulations!

#### Warning!

Drive systems can carry high levels of electrical voltage. Never connect or disconnect the connector when voltage is present!

#### Information:

ACOPOSmotor Compact modules are only permitted to be wired using the cables provided by B&R for this purpose. see "Cables" on page 379

#### 4.4.10.1 Hybrid cable - Pinout

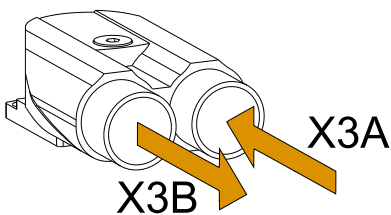

ACOPOSmotor Compact modules are equipped with two connections for hybrid cables; as a result, only one cable to the control cabinet is needed. The hybrid cable transmits both the power supply and POWERLINK communication. Additional ACOPOSmotor Compact modules are easily added on via daisy-chain cabling.

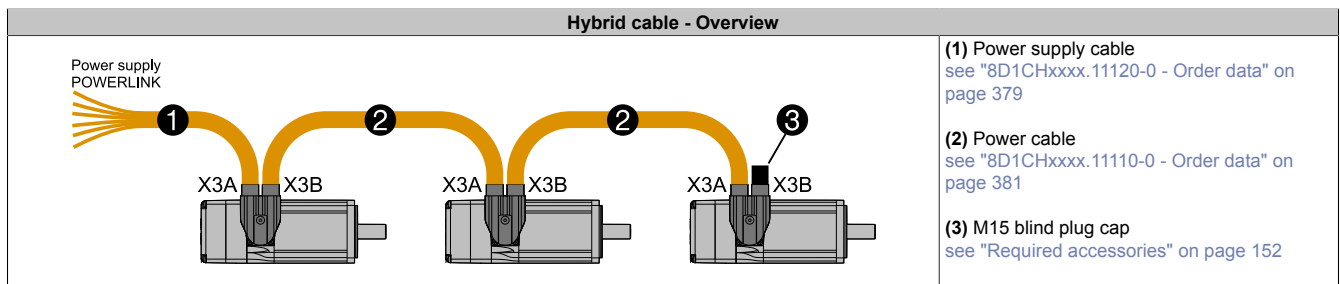

#### (1) Power supply cable (X3A / control cabinet)

915 connector 2+3+Bus female	Pin	Function	Color	Pin	RJ45 connector
	1	DC bus +	Red	---	
	2	DC bus -	Black	---	
	B	Receive signal inverted	---	6	
	C	Receive signal	---	3	
	D	Transmit signal	---	1	
	E	Transmit signal inverted	---	2	
	F	Enable signal -	Brown	---	
	G	Enable signal +	Violet	---	

### 4.4.10.2 Electronics option - Pinout

8D1bcd.G..., 8D1bcd.H..., 8D1bcd.I...	
	<p><b>X23A</b> 24 VOut + trigger see "X67CA0D40.0... and X67CA0D50.0" on page 383 - Cables</p> <p><b>X24A</b> 24 VOut + trigger see "X67CA0D40.0... and X67CA0D50.0" on page 383 - Cables</p>

#### X23A, X24A (trigger)

Figure	Pin	Description	Function
	1	+24 V	Sensor/actuator power supply 24 VDC <sup>1)</sup>
	3	GND	GND
	4	Trigger	Trigger input

Table 178: X23A, X24A connector - Pinout

1) An external sensor/actuator power supply is not permitted.

### 4.4.11 POWERLINK node number setting

The POWERLINK node number can be set using the two hexadecimal coded rotary switches located on the back of the module:

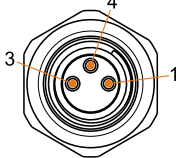
Figure	Coded rotary switches	POWERLINK node number
	1	16s position (high)
	2	1s position (low)
<p>A change to the POWERLINK node number only takes effect the next time the drive system is switched on.</p> <p><b>Information:</b></p> <p>In principle, node numbers between \$01 and \$FD are permitted. However, node numbers between \$F0 and \$FD are intended for future system expansions. To ensure compatibility, these node numbers should be avoided.</p> <p>Node numbers \$00, \$FE and \$FF are reserved and are therefore not permitted to be set.</p>		

Table 179: POWERLINK node number setting

## 5 Dimensioning

### 5.1 ACOPOSremote

#### 5.1.1 Power supply

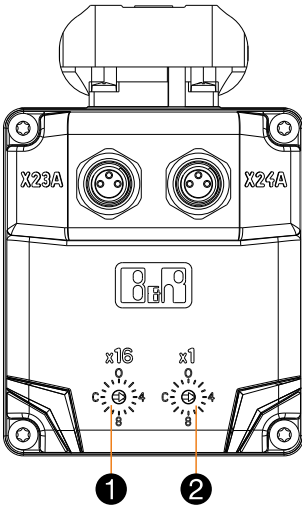
Power is supplied to ACOPOSremote 8CVI modules via the X3A connection.

#### Caution!

The power supply for ACOPOSremote 8CVI modules is only permitted to be provided via an ACOPOS-multi drive system (8BVE expansion module), the DC bus of an ACOPOS P3 8EI servo drive or a decentralized 8CVE connection box!

#### Warning!

ACOPOSremote drive systems are suitable for networks that can supply a maximum short-circuit current (SCCR) of  $65 \text{ kA}_{\text{eff}}$  at  $480 \text{ V}_{\text{eff}}$  and are protected with class J fuses<sup>3)</sup>.

#### Warning!

ACOPOSremote drive systems provide integral solid state short circuit protection. Integral solid state short circuit protection does not provide branch circuit protection. Branch circuit protection must be provided in accordance with the National Electrical Code and any additional local codes.

#### Warning!

The opening of the branch-circuit protective device may be an indication that a fault current has been interrupted. To reduce the risk of fire or electric shock, current-carrying parts and other components of the controller should be examined and replaced if damaged. If burnout of the current element of an overload relay occurs, the complete overload relay must be replaced.

#### 5.1.2 Protective ground connection

The following information concerning the protective ground connection corresponds to IEC 61800-5-1; see figure 15: Connection elements for the protective ground conductor - this must be observed.

A protective ground conductor must be connected to the 8CVI inverter module.

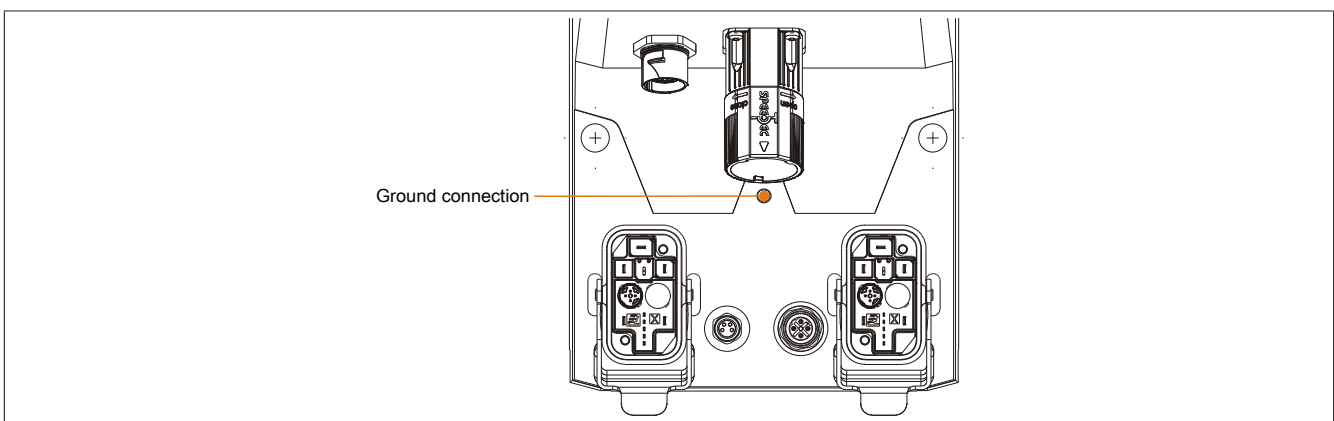

Figure 59: Connection elements for the protective ground conductor

#### Line cross section

The line cross section of the protective ground conductor is oriented to the line conductors and must be selected according to the following table:

<sup>3)</sup> ACOPOSmulti65 8CVI045x1HCS0.00-1 inverter modules are also protected with class CC or RK5 fuses

Line cross section for line conductor A [mm <sup>2</sup> ]	Minimum wire cross section for the protective ground connection A <sub>PE</sub> [mm <sup>2</sup> ] <sup>1)</sup>
$A \leq 16$	$A_{PE} = A$
$16 < A \leq 35$	$A_{PE} = 16$
$35 < A$	$A_{PE} = A / 2$

Table 180: Selecting the cross section of the protective ground conductor

- 1) Any protective ground conductor that is not part of a cable must have a minimum wire cross section of 4 mm<sup>2</sup>.

### 5.1.3 Motor connection

On B&R motors, the power connections, connections for the holding brake and connections for the motor temperature sensor are all made using the same motor connector.

The motor connection is made via the ACOPOSremote inverter module on the ACOPOSremote drive system. The motor connection must be shielded appropriately.

The following figure illustrates how the motor connection is designed:

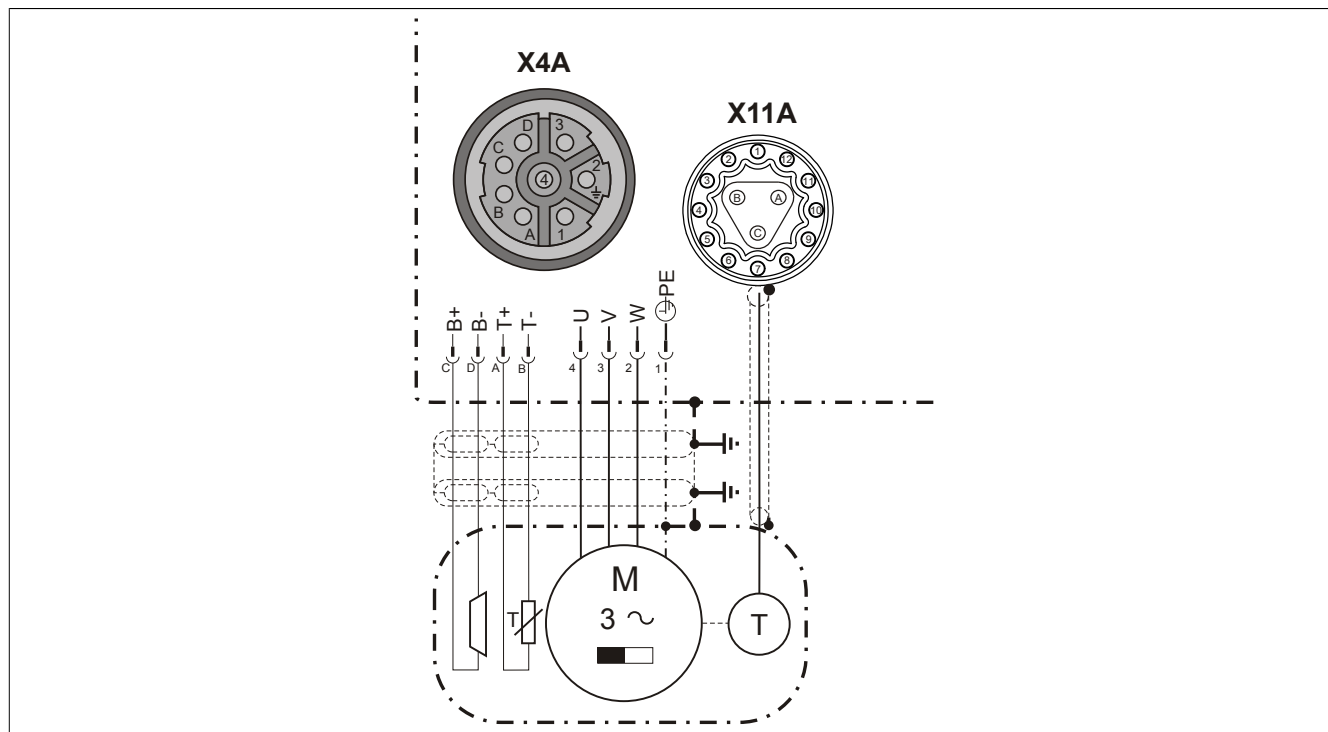

Figure 60: ACOPOSremote inverter modules, motor connection - Circuit diagram

The cross section of the motor cable must be dimensioned for the thermal equivalent RMS value of the motor current.

If information about load torques, inertias and friction is available, the thermal equivalent RMS value of the motor current for the motor being used can be calculated as follows:

$$I_q[A] = \sqrt{\frac{1}{T_{cycl}[s]} \cdot \sum_i I_i[A]^2 \cdot t_i[s]}$$

The cross section of the motor cable is selected for B&R motor cables according to the following table so that the permissible current-carrying capacity of the selected cable cross section is greater than or equal to the thermal equivalent RMS value of the motor current:

$$I_B \geq I_Z$$

#### Motor cables - For use in cable drag chains

The following table shows the current-carrying capacity of specially insulated three-phase cables per DIN VDE 0298-4 at an ambient temperature of 40°C<sup>4)</sup> and maximum cable temperature of 90°C:

Wire cross section [mm <sup>2</sup> ]	Maximum current load on the wire I <sub>Z</sub> [A] depending on type of installation		
	Installation in electrical installation pipes	Installation on a wall	Installation in the air
	B2	C	E
0.75	11.5	13	13.5
1.5	17.8	20	20.9
2.5	23.7	27.3	29.1

Table 181: Maximum current load for specially insulated three-phase cables

<sup>4)</sup> Current-carrying capacity is specified in DIN VDE 0298-4 for an ambient temperature of 30°C. The values listed in the "Current-carrying capacity of PVC-insulated three-phase cables or single conductors" table are converted for use at an ambient temperature of 40°C using the factor  $k_{Temp} = 0.91$  specified in the standard.

The specified current-carrying capacity does not take into account a reduction factor for groups of cables and single conductors. If necessary, this must be taken from the corresponding standards and included in the calculation.

Wire cross section [mm <sup>2</sup> ]	Maximum current load on the wire I <sub>z</sub> [A] depending on type of installation		
	Installation in electrical installation pipes	Installation on a wall	Installation in the air
	B2	C	E
4	31.9 <sup>1)</sup>	36.4 <sup>1)</sup>	38.2 <sup>1)</sup>
6	40	47.3	49.1
10	54.6	64.6	68.3
16	72.8	87.4	91
25	95.6	108.3	115.6
35	116.5	133.8	143.8
50	140.1	162.9	174.7

Table 181: Maximum current load for specially insulated three-phase cables

1) Pre-assembled 8BCMxxxxx.1312A-0 motor cables from B&R are only permitted to be loaded with max. 30 A.

### Motor cables - Not for use in cable drag chains

The following table shows the current-carrying capacity of PVC-insulated three-phase cables per DIN VDE 0298-4 at an ambient temperature of 40°C<sup>5)</sup> and maximum cable temperature of 70°C:

Wire cross section [mm <sup>2</sup> ]	Maximum current load on the wire I <sub>z</sub> [A] depending on type of installation		
	Installation in electrical installation pipes	Installation on a wall	Installation in the air
	B2	C	E
0.75	8.5	9.8	10.4
1.5	13.1	15.2	16.1
2.5	17.4	20.9	21.8
4	23.5	27.9	29.6
6	29.6	35.7	37.4
10	40	51.7	52.2

Table 182: Maximum current load for PVC-insulated three-phase cables

### Information:

**Observe the minimum permissible supply voltage of the motor holding brake!**

**This value is listed in the data sheet for the motor being used.**

<sup>5)</sup> Current-carrying capacity is specified in DIN VDE 0298-4 for an ambient temperature of 30°C. The values listed in the "Current-carrying capacity of PVC-insulated three-phase cables or single conductors" table are converted for use at an ambient temperature of 40°C using the factor  $k_{Temp} = 0.91$  specified in the standard.

The specified current-carrying capacity does not take into account a reduction factor for groups of cables and single conductors. If necessary, this must be taken from the corresponding standards and included in the calculation.

## 5.1.4 Connecting ACOPOSremote 8CVI inverter modules to the ACOPOSmulti drive system

### **Warning!**

The DC power supply fuse protection of the ACOPOSremote 8CVI inverter modules is only permitted to be fused in the 8BVE expansion module using fuses 50 201 06.50 or 50 11806.20 from SIBA.

### 5.1.4.1 Procedure

### **Note:**

The electrical installation must comply with national regulations and laws.

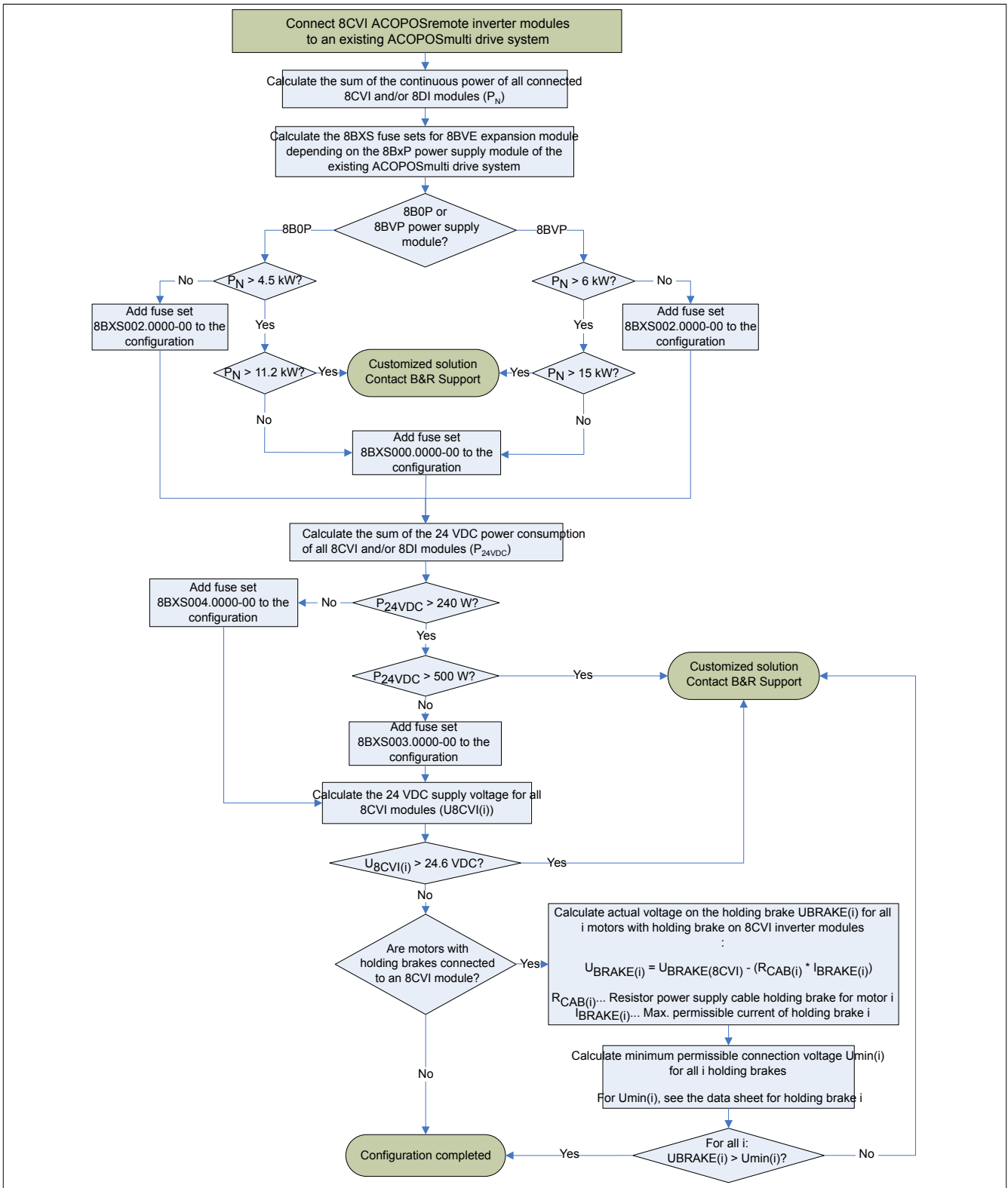

Figure 61: Procedure for connecting ACOPOSremote 8CVI inverter modules to an ACOPOSmulti drive system

### 5.1.4.2 Example

The following ACOPOSremote 8CVI inverter modules should be connected to an ACOPOSmulti drive system:

- 2 x 8CVI045E1HCS0.00-1
- 2 x 8CVI045E1HCS0.00-1, with connected motor with motor holding brake
- 1 x 8CVI045E1HCS0.00-1, with connected motor with motor holding brake and 24 VDC consumer (2 x X67DM9321.L12: 24 VDC power consumption, 75 W each)

Holding brakes BRAKE1...3: Minimum permissible connection voltage:  $U_{\min}$  22 V, maximum 24 VDC power consumption: 20 W ( $P_{\text{HoldingBrake}}$ )

For cable lengths, see Fig. 62 "8CVI wiring with an ACOPOSmulti drive system":

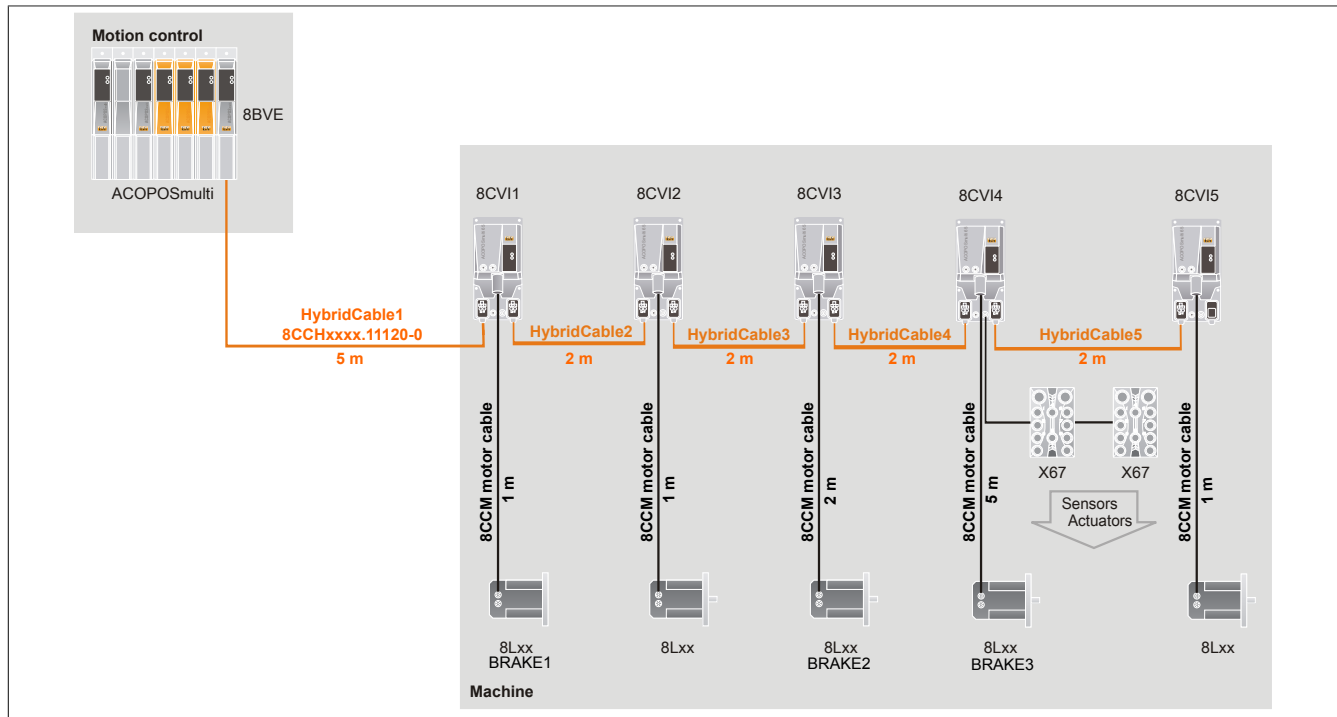

Figure 62: 8CVI wiring with an ACOPOSmulti drive system

#### 5.1.4.2.1 Calculation

##### Step 1) determine total continuous consumption of all connected 8CVI modules ( $P_N$ )

The continuous power is 1.5 kW for each 8CVI module.

$$P_N = 5 \times 1.5 \text{ kW} = 7.5 \text{ kW}$$

- ⇒ The sum of the continuous power of all 8CVI modules ( $P_N$ ) is lower than the upper limit of 11.2 kW or 15 kW (depending on the selected fuse in the 8BVE expansion module). These 8CVI modules can be connected to the ACOPOSmulti drive system.
- ⇒ Select the fuse set for the 8BVE expansion module based on the continuous power of all modules and the selected power supply module (8B0P or 8BVP) according to "Procedure for connecting ACOPOSremote 8CVI inverter modules to an ACOPOSmulti drive system" on page 258. Fuse set 8BXS001.0000-00 must be chosen in this example.

**Step 2) Determine the total 24 VDC power consumption of all 8CVI modules ( $P_{24VDC}$ )**

ACOPOSremote modules		Quantity	Calculation of the 24 VDC power consumption
8CVI2	8CVI045E1HCS0.00-1	1	$10\text{ W} + P_{24\text{ V out}} + P_{\text{Holding brake}} + P_{\text{Trigger}}$ $= 10\text{ W} + 0\text{ W} + 0\text{ W} + 0\text{ W}$ $= 10\text{ W}$
8CVI5	8CVI045E1HCS0.00-1	1	$10\text{ W} + P_{24\text{ V out}} + P_{\text{Holding brake}} + P_{\text{Trigger}}$ $= 10\text{ W} + 0\text{ W} + 0\text{ W} + 0\text{ W}$ $= 10\text{ W}$
8CVI11	8CVI045E1HCS0.00-1, incl. connected motor with holding brake	1	$10\text{ W} + P_{24\text{ V out}} + P_{\text{Holding brake}} + P_{\text{Trigger}}$ $= 10\text{ W} + 0\text{ W} + 20\text{ W} + 0\text{ W}$ $= 30\text{ W}$
8CVI13	8CVI045E1HCS0.00-1, incl. connected motor with holding brake	1	$10\text{ W} + P_{24\text{ V out}} + P_{\text{Holding brake}} + P_{\text{Trigger}}$ $= 10\text{ W} + 0\text{ W} + 20\text{ W} + 0\text{ W}$ $= 30\text{ W}$
8CVI14	8CVI045E1HCS0.00-1, incl. connected motor with holding brake and 24 VDC consumer	1	$10\text{ W} + P_{24\text{ V out}} + P_{\text{Holding brake}} + P_{\text{Trigger}}$ $= 10\text{ W} + (2 \times 75\text{ W}) + 20\text{ W} + 0\text{ W}$ $= 180\text{ W}$
<b>Sum of 24 VDC power consumption <math>P_{24VDC}</math></b>			<b>= 260 W</b>

⇒ The sum of the 24 VDC power consumption of all 8CVI modules ( $P_{24VDC}$ ) is less than the upper limit of 500 W. These 8CVI modules can be connected to the ACOPOSmulti drive system.

**Step 3) Calculation of the 24 VDC internal supply voltage at the 8BVE expansion module ( $U_{24VDC1calc}$ )**

To ensure the functionality of the 8CVI modules of the drive system, the last 8CVI module of the drive system must be supplied with at least 18 VDC. For an estimation, voltage of at least 18 V is assumed on the last 8CVI module for the calculation. By calculating using the known power consumption and cable resistances, it is possible to calculate back to a supply voltage of  $U_{24VDC1calc}$ . This calculated voltage must then be compared with the minimum permissible voltage (according to the technical data in the respective user's manual):

$U_{24VDC1calc} < 24.6\text{ V}$  (25 V - 1.6%) ... Dimensioning OK

$U_{24VDC1calc} > 24.6\text{ V}$  (25 V - 1.6%) ... Voltage drop in drive system is too high

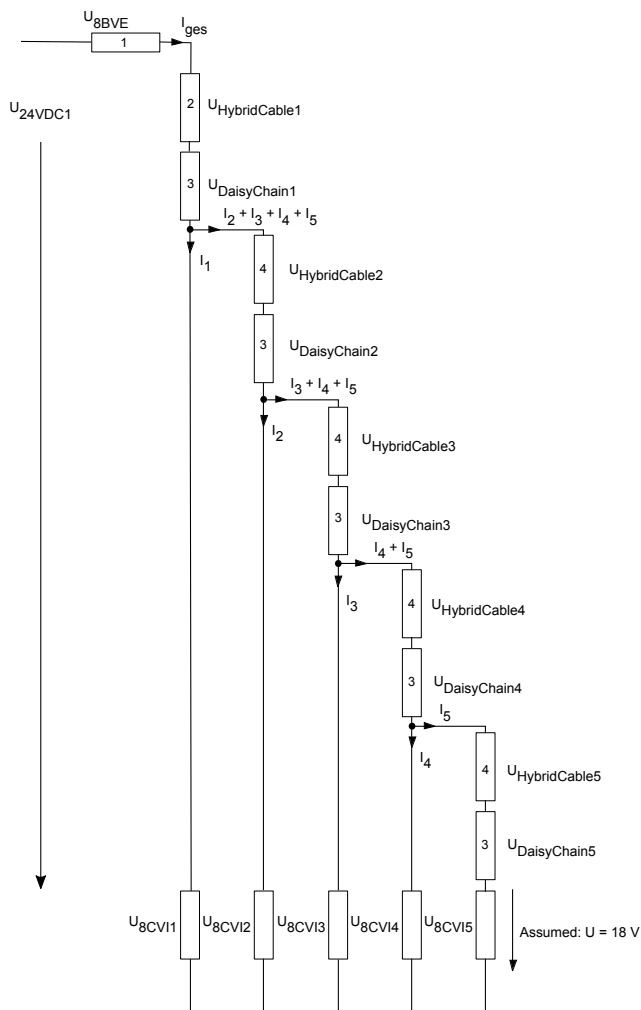

Figure 63: ACOPOSremote drive system - Equivalent circuit diagram

$$I_5 = \frac{P_5}{U} = \frac{10W}{18V} = 0.5A$$

$$U_{DaisyChain5} = 0.007\Omega * I_5 = 0.007\Omega * 0.5A = 0.004V$$

$$U_{HybridCable5} = 0.031\Omega * I_5 = 0.031\Omega * 0.5A = 0.016V$$

$$U_{8CVI5} = 18V + U_{DaisyChain5} + U_{HybridCable5} = 18V + 0.004V + 0.016V = 18.02V$$

$$I_4 = \frac{P_4}{U_{8CVI5}} = \frac{180W}{18.02V} = 9.99A$$

$$U_{DaisyChain4} = 0.007\Omega * (I_4 + I_5) = 0.007\Omega * (9.99A + 0.5A) = 0.07V$$

$$U_{HybridCable4} = 0.031\Omega * (I_4 + I_5) = 0.031\Omega * (9.99A + 0.5A) = 0.33V$$

$$U_{8CVI4} = 18.02V + U_{DaisyChain4} + U_{HybridCable4} = 18.02V + 0.07V + 0.33V = 18.42V$$

$$I_3 = \frac{P_3}{U_{8CVI4}} = \frac{30W}{18.42V} = 1.63A$$

$$U_{DaisyChain3} = 0.007\Omega * (I_3 + I_4 + I_5) = 0.007\Omega * (1.63A + 9.99A + 0.5A) = 0.08V$$

$$U_{HybridCable3} = 0.031\Omega * (I_3 + I_4 + I_5) = 0.031\Omega * (1.63A + 9.99A + 0.5A) = 0.38V$$

$$U_{8CVI3} = 18.42V + U_{DaisyChain3} + U_{HybridCable3} = 18.42V + 0.08V + 0.38V = 18.88V$$

$$I_2 = \frac{P_2}{U_{8CVI3}} = \frac{10W}{18.88V} = 0.53A$$

$$U_{DaisyChain2} = 0.007\Omega * (I_2 + I_3 + I_4 + I_5) = 0.007\Omega * (0.53A + 1.63A + 9.99A + 0.5A) = 0.09V$$

$$U_{HybridCable2} = 0.031\Omega * (I_2 + I_3 + I_4 + I_5) = 0.031\Omega * (0.53A + 1.63A + 9.99A + 0.5A) = 0.39V$$

$$U_{8CVI2} = 18.88V + U_{DaisyChain2} + U_{HybridCable2} = 18.88V + 0.09V + 0.39V = 19.35V$$

$$I_1 = \frac{P_1}{U_{8CVI2}} = \frac{30W}{19.35V} = 1.55A$$

$$U_{DaisyChain1} = 0.007\Omega * (I_1 + I_2 + I_3 + I_4 + I_5) = 0.007\Omega * (1.55A + 0.53A + 1.63A + 9.99A + 0.5A) = 0.1V$$

$$U_{HybridCable1} = 0.078\Omega * (I_1 + I_2 + I_3 + I_4 + I_5) = 0.078\Omega * (1.55A + 0.53A + 1.63A + 9.99A + 0.5A) = 1.1V$$

$$U_{8BVE} = 0.029\Omega * (I_1 + I_2 + I_3 + I_4 + I_5) = 0.029\Omega * (1.55A + 0.53A + 1.63A + 9.99A + 0.5A) = 0.4V$$

$$U_{24VDC1} = 19.35V + U_{DaisyChain1} + U_{HybridCable1} + U_{8BVE} = 19.35V + 0.1V + 1.1V + 0.4V = 20.95V$$

- (3)  $R_{DaisyChain} \dots 0.007 \Omega$   
 (1)  $R_{8BVE} \dots 0.029 \Omega$   
 (2)  $R_{HybridCable1} \dots 0.078 \Omega$   
 (4)  $R_{HybridCable2-5} \dots 0.031 \Omega$

⇒ Result:  $U_{24VDC1calc} < 24.6 V$  (25 V - 1.6%)

These 8BVI modules can be connected to the ACOPOSmulti drive system.

#### Step 4) Determine the actual voltage on the holding brake1...3

$$U_{BRAKE(i)} = U_{BRAKE(8CV(i))} - (R_{CAB(i)} * I_{BRAKE(i)})$$

$$U_{BRAKE1} = U_{BRAKE(8CV1)} - (R_{CAB1} * I_{BRAKE1}) = 24V - (0.03\Omega * 0.91A) = 23.97V$$

$$U_{BRAKE2} = U_{BRAKE(8CV3)} - (R_{CAB2} * I_{BRAKE2}) = 24V - (0.06\Omega * 0.91A) = 23.94V$$

$$U_{BRAKE3} = U_{BRAKE(8CV4)} - (R_{CAB3} * I_{BRAKE3}) = 24V - (0.15\Omega * 0.91A) = 23.86V$$

For  $R_{CAB(i)}$ , see the technical data for the respective cables. If this value is not found, it can be calculated as follows:

$$R_{CAB(i)} = \rho * l/A \quad 6)$$

⇒ The voltage is more than 22 V for all holding brakes.

6)  $\rho$  ... Specific resistance  
 $l$  ... 2x line length (outward and return line)  
 $A$  ... Wire cross section

## Symbols used

Symbol	Name
$P_{24VDC}$	Total power
$P_N$	Sum of the continuous power of all 8CVI modules
$P_{1...5}$	24 VDC power consumption of the 8CVI inverter module
$U_{24VDC}$	+24 VDC internal system power supply of the ACOPOSmulti drive system
$U_{24VDC1calc}$	Calculated +24 VDC internal system voltage supply at the 8BVE expansion module
$U_{8CVI2...5}$	+24 VDC voltage in the 8CVI inverter module
$U_{8BVE}$	Internal 24 VDC voltage drop in the 8BVE expansion module
$U_{Hybrid\ cable1...5}$	Internal 24 VDC voltage drop in the 8CCH cable
$U_{Daisychain(i)}$	Internal 24 VDC voltage in the 8CVI inverter module
$U_{BRAKE(i)}$	Actual voltage on the holding brake
$U_{BRAKE(8CVI)}$	Minimum voltage at the motor holding brake output of an 8CVI module
$R_{CAB(i)}$	Resistance of brake line in motor cable for Motor i
$I_{BRAKE(i)}$	Max. permitted current for holding brake i
$R_{DaisyChain}$	Resistance in the 8CVI inverter module
$R_{8BVE}$	Resistance in the 8BVE expansion module
$R_{HybridCable}$	Conductor resistance of power conductors in the 8CCH cable

## 5.1.5 Connecting ACOPOSremote 8CVI inverter modules to the ACOPOS P3 drive system

### 5.1.5.1 Procedure

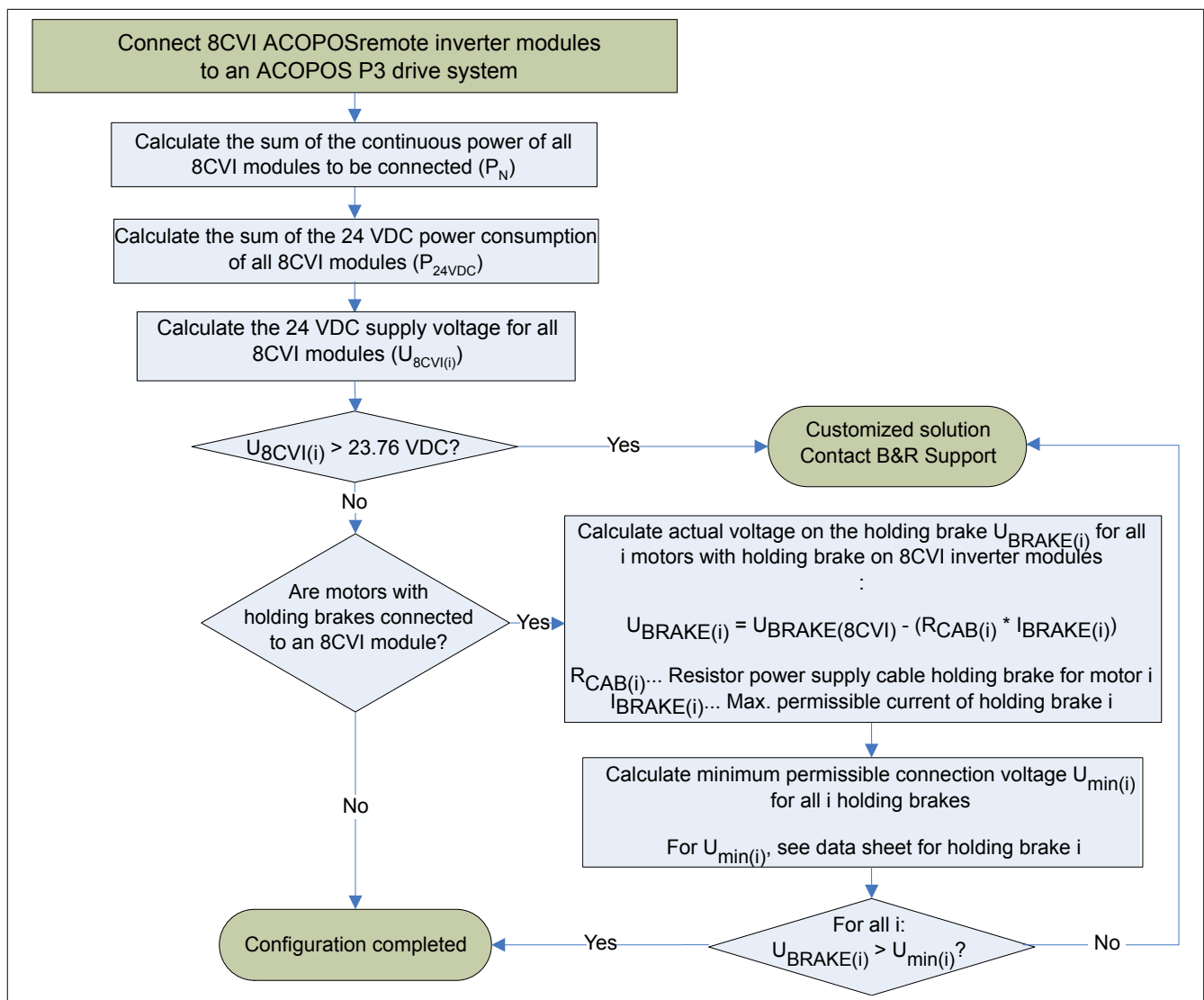

Figure 64: Procedure for connecting ACOPOSremote 8CVI inverter modules to an ACOPOS P3 drive system

### 5.1.5.2 Example

The following ACOPOSremote 8CVI inverter modules should be connected to an ACOPOS P3 drive system:

- 2 x 8CVI045E1HCS0.00-1
- 2 x 8CVI045E1HCS0.00-1, with connected motor with motor holding brake
- 1 x 8CVI045E1HCS0.00-1, with connected motor with motor holding brake and 24 VDC consumer (2 x X67DM9321.L12: 24 VDC power consumption, 75 W each)
- Power supply unit 24 VDC 0PS3200.1, max. output power 480 W
- 1 x 8EI2X2HWT10.XXXX-1, self-consumption 24 VDC

Holding brakes BRAKE1...3: Minimum permissible connection voltage:  $U_{\min}$  22 V, maximum 24 VDC power consumption: 20 W ( $P_{\text{holding brake}}$ )

For cable lengths, see Fig. 65 "8CVI wiring with an ACOPOS P3 drive system":

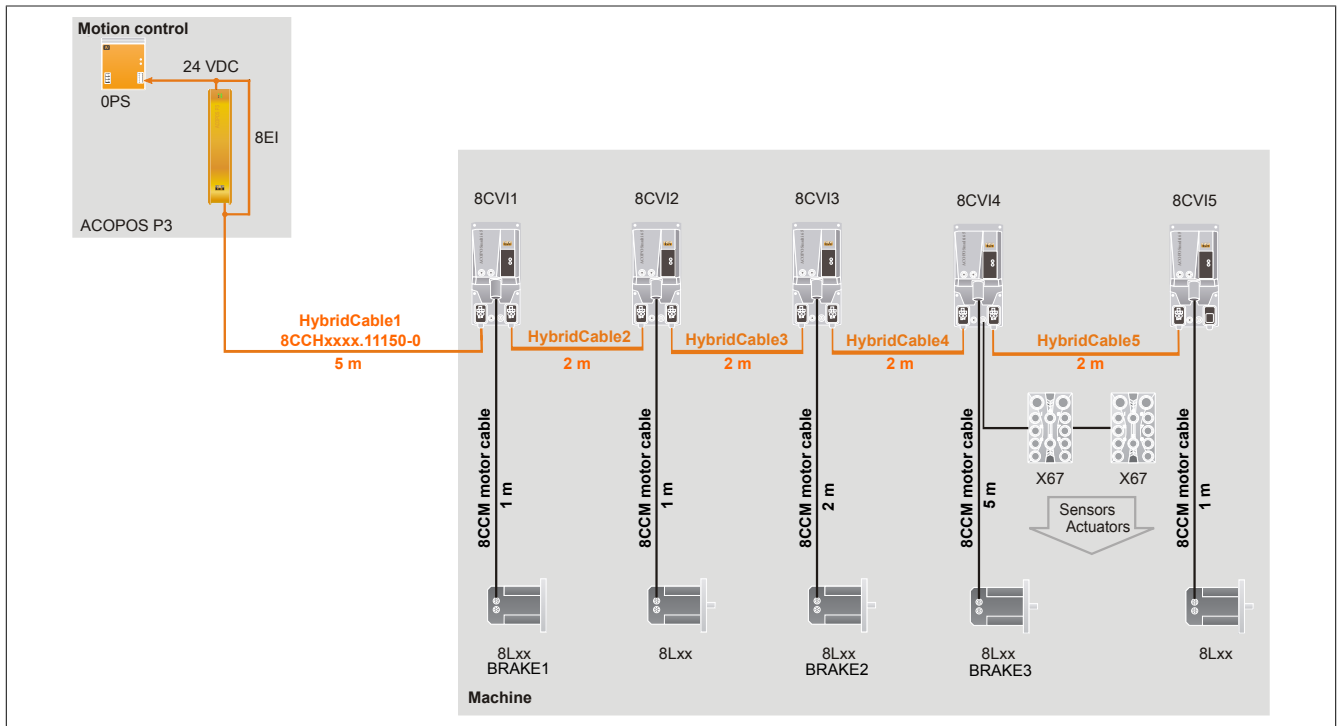

Figure 65: 8CVI wiring with an ACOPOS P3 drive system

#### 5.1.5.2.1 Calculation

**Step 1) Calculate the sum of the continuous power consumption of all connected 8CVI modules ( $P_N$ )**

The continuous power is 1.5 kW for each 8CVI module.

$$P_N = 5 \times 1.5 \text{ kW} = 7.5 \text{ kW}$$

**Step 2) Calculate the sum of the 24 VDC power consumption of all 8CVI modules ( $P_{24VDC}$ )**

ACOPOSremote modules	Quantity	Calculation of the 24 VDC power consumption
8CVI045E1HCS0.00-1	1	$10 \text{ W} + P_{24 \text{ V out}} + P_{\text{Holding brake}} + P_{\text{Trigger}}$ $= 10 \text{ W} + 0 \text{ W} + 0 \text{ W} + 0 \text{ W}$ $= 10 \text{ W}$
8CVI045E1HCS0.00-1	1	$10 \text{ W} + P_{24 \text{ V out}} + P_{\text{Holding brake}} + P_{\text{Trigger}}$ $= 10 \text{ W} + 0 \text{ W} + 0 \text{ W} + 0 \text{ W}$ $= 10 \text{ W}$
8CVI045E1HCS0.00-1, including connected motor with motor holding brake	1	$10 \text{ W} + P_{24 \text{ V out}} + P_{\text{Holding brake}} + P_{\text{Trigger}}$ $= 10 \text{ W} + 0 \text{ W} + 20 \text{ W} + 0 \text{ W}$ $= 30 \text{ W}$
8CVI045E1HCS0.00-1, including connected motor with motor holding brake	1	$10 \text{ W} + P_{24 \text{ V out}} + P_{\text{Holding brake}} + P_{\text{Trigger}}$ $= 10 \text{ W} + 0 \text{ W} + 20 \text{ W} + 0 \text{ W}$ $= 30 \text{ W}$
8CVI045E1HCS0.00-1, including connected motor with motor holding brake and 24 VDC consumer	1	$10 \text{ W} + P_{24 \text{ V out}} + P_{\text{Holding brake}} + P_{\text{Trigger}}$ $= 10 \text{ W} + (2 \times 75 \text{ W}) + 20 \text{ W} + 0 \text{ W}$ $= 180 \text{ W}$
<b>ACOPOS P3 modules</b>		
8EI2X2HWT10.XXXX-1	1	$P_{\text{HoldingBrake}} + P_{24 \text{ VDC}, 8EI}$ $= 0 \text{ W} + 1.2 \text{ A} \cdot 24 \text{ VDC}$ $= 28.8 \text{ W}$
<b>Sum of 24 VDC power consumption <math>P_{24VDC}</math></b>		<b>= 288.8 W</b>

⇒ The sum of the 24 VDC power consumption of all modules ( $P_{24VDC}$ ) is less than the upper limit of 840 W.

**Step 3) Calculate the 24 VDC internal supply voltage ( $U_{24VDC1calc}$ )**

The minimum voltage of 18 V must be maintained on the last module of the drive system to ensure that the drive system functions properly. For an estimation, voltage of at least 18 V is assumed on the last module for the calculation. By calculating using the existing power consumption and cable resistances, it is possible to calculate back to a supply voltage of  $U_{24VDC1calc}$ . This calculated voltage must then be compared with the minimum permissible voltage (according to the technical data in the respective manual):

$U_{24VDC1calc} < 23.76 \text{ V}$  (24 V - 1%) ... Dimensioning OK

$U_{24VDC1calc} > 23.76 \text{ V}$  (24 V - 1%) ... Voltage drop in the drive system too high

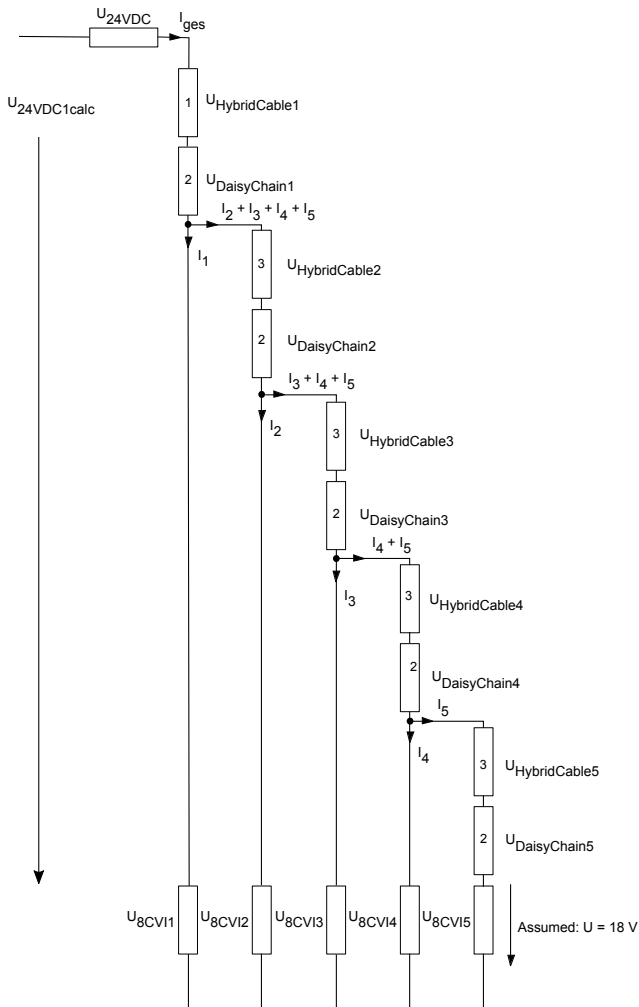

$$I_5 = \frac{P_5}{U} = \frac{10W}{18V} = 0.55A$$

$$U_{Daisychain5} = 0.007\Omega \cdot I_5 = 0.007\Omega \cdot 0.55A = 0.004V$$

$$U_{Hybridkabel5} = 0.031\Omega \cdot I_5 = 0.031\Omega \cdot 0.55A = 0.017V$$

$$U_{8CVI5} = 18V + U_{Daisychain5} + U_{Hybridkabel5} = 18V + 0.004V + 0.017V = 18.02V$$

$$I_4 = \frac{P_4}{U_{8CVI4}} = \frac{10W}{18.02V} = 9.99A$$

$$U_{Daisychain4} = 0.007\Omega \cdot (I_4 + I_5) = 0.007\Omega \cdot (9.99A + 0.55A) = 0.07V$$

$$U_{Hybridkabel4} = 0.031\Omega \cdot (I_4 + I_5) = 0.031\Omega \cdot (9.99A + 0.55A) = 0.33V$$

$$U_{8CVI4} = 18.02V + U_{Daisychain4} + U_{Hybridkabel4} = 18.02V + 0.07V + 0.33V = 18.42V$$

$$I_3 = \frac{P_3}{U_{8CVI3}} = \frac{10W}{18.42V} = 1.63A$$

$$U_{Daisychain3} = 0.007\Omega \cdot (I_3 + I_4 + I_5) = 0.007\Omega \cdot (1.63A + 9.99A + 0.55A) = 0.08V$$

$$U_{Hybridkabel3} = 0.031\Omega \cdot (I_3 + I_4 + I_5) = 0.031\Omega \cdot (1.63A + 9.99A + 0.55A) = 0.38V$$

$$U_{8CVI3} = 18.42V + U_{Daisychain3} + U_{Hybridkabel3} = 18.42V + 0.08V + 0.38V = 18.88V$$

$$I_2 = \frac{P_2}{U_{8CVI2}} = \frac{10W}{18.88V} = 0.53A$$

$$U_{Daisychain2} = 0.007\Omega \cdot (I_2 + I_3 + I_4 + I_5) = 0.007\Omega \cdot (0.53A + 1.63A + 9.99A + 0.55A) = 0.09V$$

$$U_{Hybridkabel2} = 0.031\Omega \cdot (I_2 + I_3 + I_4 + I_5) = 0.031\Omega \cdot (0.53A + 1.63A + 9.99A + 0.55A) = 0.39V$$

$$U_{8CVI2} = 18.88V + U_{Daisychain2} + U_{Hybridkabel2} = 18.88V + 0.08V + 0.39V = 19.35V$$

$$I_1 = \frac{P_1}{U_{8CVI1}} = \frac{10W}{19.35V} = 1.55A$$

$$U_{Daisychain1} = 0.007\Omega \cdot (I_1 + I_2 + I_3 + I_4 + I_5) = 0.007\Omega \cdot (1.55A + 0.53A + 1.63A + 9.99A + 0.55A) = 0.1V$$

$$U_{Hybridkabel1} = 0.078\Omega \cdot (I_1 + I_2 + I_3 + I_4 + I_5) = 0.078\Omega \cdot (1.55A + 0.53A + 1.63A + 9.99A + 0.55A) = 1.1V$$

$$U_{24VDC1calc} = 19.35V + U_{Daisychain1} + U_{Hybridkabel1} = 19.35V + 0.1V + 1.1V + 0.4V = 20.95V$$

Figure 66: ACOPOSremote drive system - Equivalent circuit diagram

- (2)  $R_{DaisyChain1-5} \dots 0.007 \Omega$
- (1)  $R_{HybridCable1} \dots 0.078 \Omega$
- (3)  $R_{HybridCable2-5} \dots 0.031 \Omega$

⇒ Result:  $U_{24VDC1calc} < 23.76 V$  (24 V - 1%)

**Step 4) Calculate the actual voltage on holding brakes BRAKE1...3**

$$U_{BRAKE(i)} = U_{BRAKE(8CV(i))} - (R_{CAB(i)} * I_{BRAKE(i)})$$

$$U_{BRAKE1} = U_{BRAKE(8CV1)} - (R_{CAB1} * I_{BRAKE1}) = 24V - (0.03\Omega * 0.91A) = 23.97V$$

$$U_{BRAKE2} = U_{BRAKE(8CV3)} - (R_{CAB2} * I_{BRAKE2}) = 24V - (0.06\Omega * 0.91A) = 23.94V$$

$$U_{BRAKE3} = U_{BRAKE(8CV4)} - (R_{CAB3} * I_{BRAKE3}) = 24V - (0.15\Omega * 0.91A) = 23.86V$$

For  $R_{CAB(i)}$ , see the technical data for the respective cables. If this value is not found, it can be calculated as follows:  
 $R_{CAB(i)} = \rho * l/A^7$ .

⇒ The voltage is more than 22 V for all holding brakes.

**Formula symbols**

Symbol	Name
$P_{24VDC}$	Total power
$P_N$	Sum of the continuous power of all 8CVI modules
$P_{1...5}$	24 VDC power consumption of the 8CVI inverter module
$U_{24VDC}$	Minimum output voltage of the +24 VDC power supply of the ACOPOS P3 drive system
$U_{24VDC1calc}$	Calculated minimum required voltage on the +24 VDC connector of the ACOPOS P3 drive system
$U_{8CVI2...5}$	+24 VDC voltage in the 8CVI inverter module
$U_{HybridCable1...5}$	Internal 24 VDC voltage drop in the 8CCH cable
$U_{DaisyChain(i)}$	Internal 24 VDC voltage drop in the 8CVI inverter module
$U_{BRAKE(i)}$	Actual voltage on the holding brake
$U_{BRAKE(8CVI)}$	Minimum voltage at the motor holding brake output of an 8CVI module
$R_{CAB(i)}$	Resistance brake supply line in motor cable for motor i
$I_{BRAKE(i)}$	Max. permissible current of holding brake i
$R_{DaisyChain}$	Resistance in the ACOPOSremote 8CVI
$R_{HybridCable}$	Resistance in the 8CCH cable

**5.2 8CVE connection box****5.2.1 Power supply**

Power is supplied to the 8CVE remote connection box via the X1 and X2 connections.

**Caution!**

Power for the 8CVE remote connection box must be supplied by an ACOPOSmulti drive system (8BVE expansion module)!

**Warning!**

ACOPOSremote drive systems are suitable for power mains that can provide a short circuit current (SCCR) of 65 kA<sub>eff</sub> at a maximum of 480 V<sub>eff</sub> and that are protected with class J fuses.

**Warning!**

ACOPOSremote drive systems provide integral solid state short circuit protection. Integral solid state short circuit protection does not provide branch circuit protection. Branch circuit protection must be provided in accordance with the National Electrical Code and any additional local codes.

**Warning!**

The opening of the branch-circuit protective device may be an indication that a fault current has been interrupted. To reduce the risk of fire or electric shock, current-carrying parts and other components of the controller should be examined and replaced if damaged. If burnout of the current element of an overload relay occurs, the complete overload relay must be replaced.

**5.2.2 Protective ground connection**

The following information concerning the protective ground connection corresponds to section "Connection elements for the protective ground conductor" in IEC 61800-5-1 and must be observed. A protective ground conductor must be connected to the CVE connection box.

<sup>7)</sup>  $\rho$  ... Specific resistance  
 $l$  ... 2x line length (outward and return line)  
 $A$  ... Wire cross section

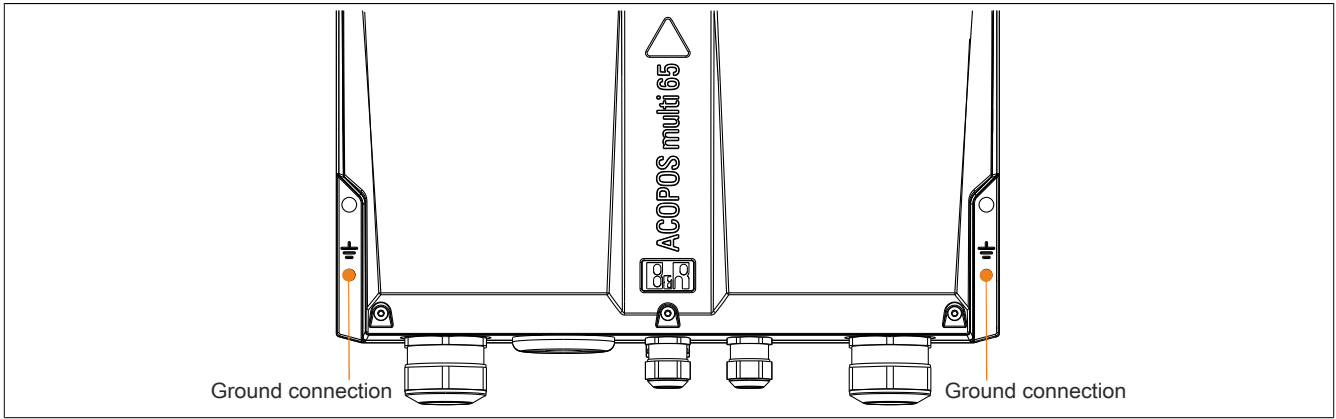

Figure 67: Protective ground connection

### Line cross section

The line cross section of the protective ground conductor is oriented to the line conductors and must be selected according to the following table:

Line cross section for line conductor A [mm <sup>2</sup> ]	Minimum wire cross section for the protective ground connection A <sub>PE</sub> [mm <sup>2</sup> ] <sup>1)</sup>
A ≤ 16	A <sub>PE</sub> = A
16 < A ≤ 35	A <sub>PE</sub> = 16
35 < A	A <sub>PE</sub> = A / 2

Table 183: Selecting the cross section of the protective ground conductor

1) Any protective ground conductor that is not part of a cable must have a minimum wire cross section of 4 mm<sup>2</sup>.

## 5.2.3 Procedure for connecting an ACOPOSremote inverter module to an existing ACOPOSmulti drive system

### 5.2.3.1 Procedure

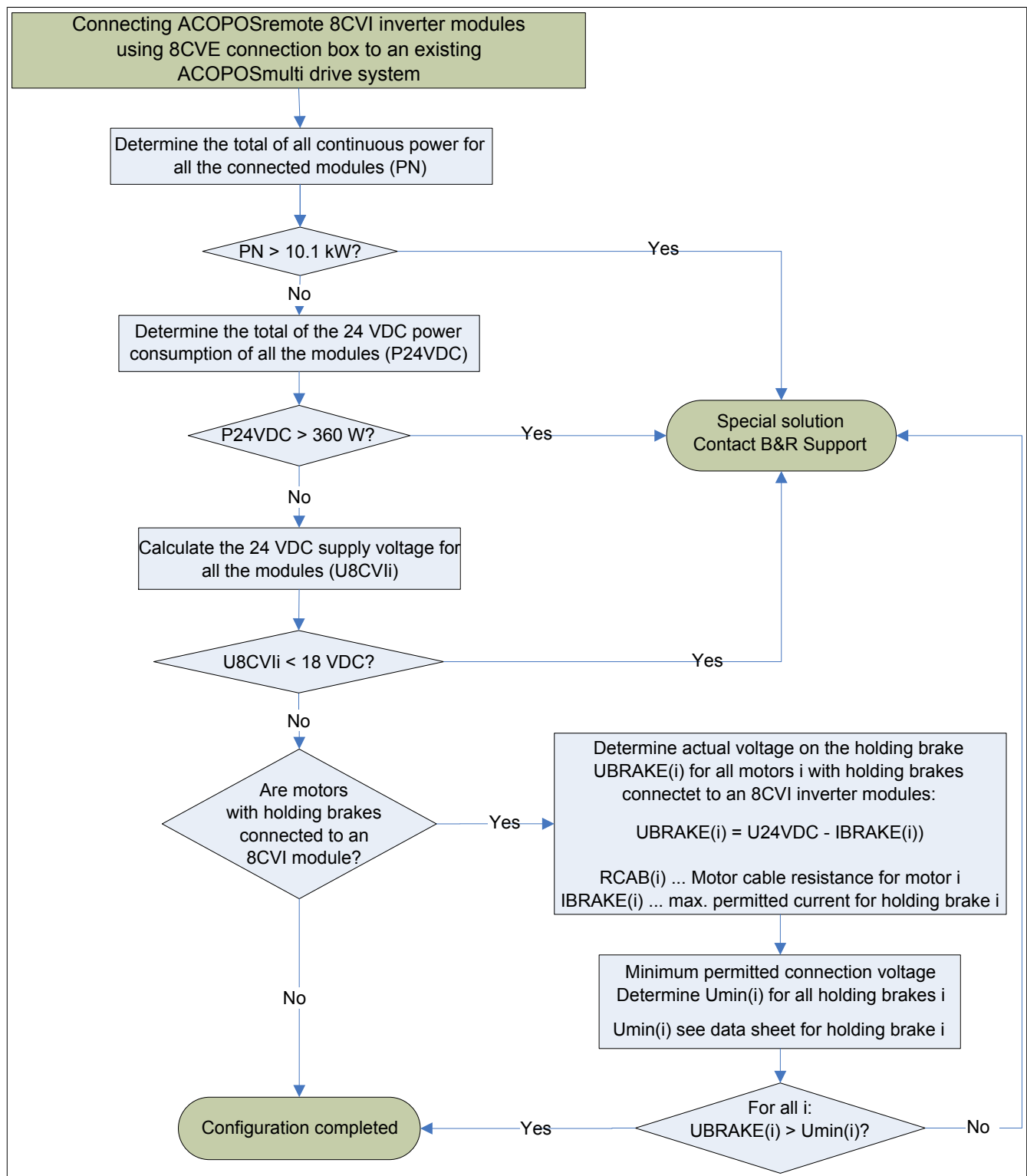
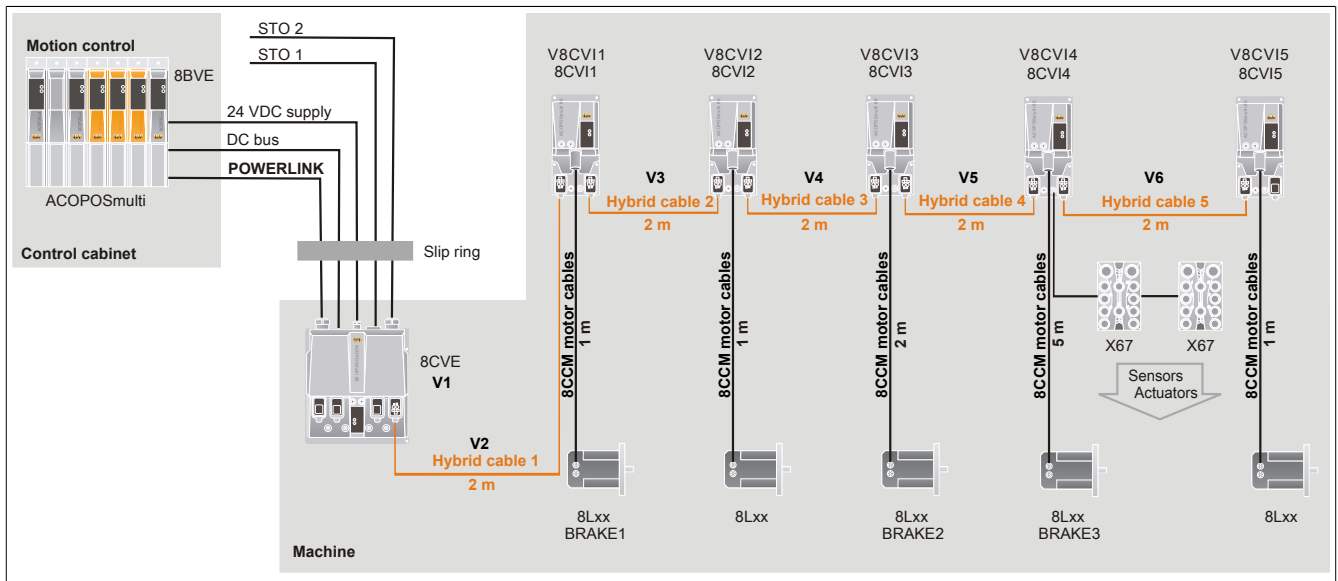

Figure 68: Procedure for connecting an ACOPOSremote inverter module to an existing ACOPOSmulti drive system

### 5.2.3.2 Example



#### 5.2.3.2.1 Calculation

The following ACOPOSremote modules should be connected to an existing ACOPOSmulti drive system:

- 1x ACOPOSremote connection box 8CVE28000HC00.00-1
- 2x ACOPOSremote inverter module 8CVI045E1HCS0.00-1
- 2x ACOPOSremote inverter module 8CVI045E1HCS0.00-1, with connected motor and motor brake
- 2x ACOPOSremote inverter module 8CVI045E1HCS0.00-1, with connected motor and motor brake with 24 VDC consumer (2x X67DM9321.L12: 24 VDC power consumption each 75 W)

BRAKE1...3: minimum permitted connection voltage:  $U_{min}$  22 V, max. 24VDC Input: 20 W ( $P_{Brake}$ )

#### Step 1) determine total continuous consumption of all connected 8CVI modules ( $P_N$ )

The continuous power per ACOPOSremote inverter module is 1.5 kW.

$$P_N = 5 \times 1.5 \text{ kW} = 7.5 \text{ kW}$$

⇒ The total of the continuous power of all the modules ( $P_N$ ) is lower than the upper limit of 10.1 kW. These modules can therefore be connected to an existing ACOPOSmulti drive system.

#### Step 2) Determine the total 24 VDC power consumption of all 8CVI modules ( $P_{24VDC}$ )

ACOPOSremote modules	Quantity	Calculation of the 24VDC power consumption
8CVI045E1HCS0.00-1	1	$10 \text{ W} + P_{24 \text{ V out}} + P_{\text{Holding brake}} + P_{\text{Trigger}}$ $= 10 \text{ W} + 0 \text{ W} + 0 \text{ W} + 0 \text{ W}$ $= 10 \text{ W}$
8CVI045E1HCS0.00-1	1	$10 \text{ W} + P_{24 \text{ V out}} + P_{\text{Holding brake}} + P_{\text{Trigger}}$ $= 10 \text{ W} + 0 \text{ W} + 0 \text{ W} + 0 \text{ W}$ $= 10 \text{ W}$
8CVI045E1HCS0.00-1, incl. connected motor with holding brake	1	$10 \text{ W} + P_{24 \text{ V out}} + P_{\text{Holding brake}} + P_{\text{Trigger}}$ $= 10 \text{ W} + 0 \text{ W} + 20 \text{ W} + 0 \text{ W}$ $= 30 \text{ W}$
8CVI045E1HCS0.00-1, incl. connected motor with holding brake	1	$10 \text{ W} + P_{24 \text{ V out}} + P_{\text{Holding brake}} + P_{\text{Trigger}}$ $= 10 \text{ W} + 0 \text{ W} + 20 \text{ W} + 0 \text{ W}$ $= 30 \text{ W}$
8CVI045E1HCS0.00-1, incl. connected motor with holding brake and 24 VDC consumer	1	$10 \text{ W} + P_{24 \text{ V out}} + P_{\text{Holding brake}} + P_{\text{Trigger}}$ $= 10 \text{ W} + (2 \times 75 \text{ W}) + 20 \text{ W} + 0 \text{ W}$ $= 180 \text{ W}$
<b>Total of the 24VDC power consumption <math>P_{24VDC}</math></b>		<b>= 260 W</b>

⇒ The total of the 24 VDC power consumption of all the modules ( $P_{24VDC}$ ) is lower than the upper limit of 360 W. These modules can therefore be connected to an existing ACOPOSmulti drive system.

#### Step 3) Calculate 24 VDC supply voltage for all 8CVI modules ( $U_{8CVI(i)}$ )

$$U_{total} = 18 \text{ V} + \sum V_{\text{Hybrid.cable } 1...5} + \sum V_{\text{Daisychain } 1...5} + V_{8CVE}$$

$$R_{\text{DaisyChain}} \dots 0.007 \Omega$$

$$R_{\text{8CVE}} \dots 0.016 \Omega$$

$$R_{\text{HybridCable}} \dots 0.031 \Omega$$

$$I_5 = \frac{P_5}{U} = \frac{10W}{18V} = 0.5A$$

$$V_{\text{DaisyChain5}} = 0.007\Omega * I_5 = 0.007\Omega * 0.5A = 0.0035V$$

$$V_{\text{HybridCable5}} = 0.031\Omega * I_5 = 0.031\Omega * 0.5A = 0.0155V$$

$$U_{\text{8CVI5}} = 18V + V_{\text{DaisyChain5}} + V_{\text{HybridCable5}} = 18V + 0.004V + 0.016V = 18.02V$$

$$I_4 = \frac{P_4}{U_{\text{8CVI5}}} = \frac{190W}{18.02V} = 10.54A$$

$$V_{\text{DaisyChain4}} = 0.007\Omega * I_4 = 0.007\Omega * 10.54A = 0.07V$$

$$V_{\text{HybridCable4}} = 0.031\Omega * I_4 = 0.031\Omega * 10.54A = 0.33V$$

$$U_{\text{8CVI4}} = 18.02V + V_{\text{DaisyChain4}} + V_{\text{HybridCable4}} = 18.02V + 0.07V + 0.33V = 18.42V$$

$$I_3 = \frac{P_3}{U_{\text{8CVI4}}} = \frac{220W}{18.42V} = 11.94A$$

$$V_{\text{DaisyChain3}} = 0.007\Omega * I_3 = 0.007\Omega * 11.94A = 0.08V$$

$$V_{\text{HybridCable3}} = 0.031\Omega * I_3 = 0.031\Omega * 11.94A = 0.37V$$

$$U_{\text{8CVI3}} = 18.42V + V_{\text{DaisyChain3}} + V_{\text{HybridCable3}} = 18.42V + 0.08V + 0.37V = 18.87V$$

$$I_2 = \frac{P_2}{U_{\text{8CVI3}}} = \frac{230W}{18.87V} = 12.18A$$

$$V_{\text{DaisyChain2}} = 0.007\Omega * I_2 = 0.007\Omega * 12.18A = 0.08V$$

$$V_{\text{HybridCable2}} = 0.031\Omega * I_2 = 0.031\Omega * 12.18A = 0.38V$$

$$U_{\text{8CVI2}} = 18.87V + V_{\text{DaisyChain2}} + V_{\text{HybridCable2}} = 18.87V + 0.08V + 0.38V = 19.38V$$

$$I_1 = \frac{P_1}{U_{\text{8CVI2}}} = \frac{260W}{19.38V} = 13.41A$$

$$V_{\text{DaisyChain1}} = 0.007\Omega * I_1 = 0.007\Omega * 13.41A = 0.09V$$

$$V_{\text{HybridCable1}} = 0.031\Omega * I_1 = 0.031\Omega * 13.41A = 0.42V$$

$$V_{\text{8CVE}} = 0.016\Omega * I_1 = 0.016\Omega * 13.41A = 0.21V$$

$$U_{\text{8CVI1}} = 19.38V + V_{\text{DaisyChain1}} + V_{\text{HybridCable1}} + V_{\text{8CVE}} = 19.38V + 0.09V + 0.42V + 0.21V = 20.1V$$

⇒ The 24 VDC supply voltage ( $U_{\text{8CVI}(i)}$ ) is less than 24.6 V (25 V - 1.6%) for all the 8CVI inverter modules and the 8CVE connection box. These modules can therefore be connected to an existing ACOPOSmulti drive system.

#### Step 4) Determine the actual voltage on the holding brake1...3

$$U_{\text{BRAKE}(i)} = U_{\text{BRAKE}(8CVI(i))} - (R_{\text{CAB}(i)} * I_{\text{BRAKE}(i)})$$

$$U_{\text{BRAKE1}} = U_{\text{BRAKE}(8CVI1)} - (R_{\text{CAB1}} * I_{\text{BRAKE1}}) = 24V - (0.03\Omega * 0.91A) = 23.97V$$

$$U_{\text{BRAKE2}} = U_{\text{BRAKE}(8CVI3)} - (R_{\text{CAB2}} * I_{\text{BRAKE2}}) = 24V - (0.06\Omega * 0.91A) = 23.94V$$

$$U_{\text{BRAKE3}} = U_{\text{BRAKE}(8CVI4)} - (R_{\text{CAB3}} * I_{\text{BRAKE3}}) = 24V - (0.15\Omega * 0.91A) = 23.86V$$

$R_{\text{CAB}(i)}$  can be found in the technical data for the relevant cable. If this value is not available, it can be calculated as follows:  $R_{\text{CAB}(i)} = \rho * l/A$  <sup>8)</sup>

⇒ The voltage for all holding brakes is greater than 22 V. These modules can therefore be connected to the existing ACOPOSmulti drive system.

<sup>8)</sup>  $\rho$  ... Specific resistance  
 $l$  ... 2x cable length (outward and return line)  
 $A$  ... Cable diameter

## Formula symbols used

Symbol	Name
$P_{24VDC}$	Total power
$P_N$	Total of all continuous power consumption of all the 8CVI modules
$P_{1...5}$	24 VDC power consumption of the 8CVI inverter module
$U_{24VDC}$	+24 VDC internal system voltage supply of the ACOPOSremote drive system
$U_{8CVI1...5}$	+24 VDC voltage in 8CVI module
$V_{8CVE}$	Internal 24 VDC voltage drop in the 8CVE connection box
$V_{Hybrid\ Cable1...5}$	Internal 24 VDC voltage drop in the 8CCH cable
$V_{Daisychain1...5}$	Internal 24 VDC voltage in the 8CVI inverter module
$U_{BRAKE(i)}$	Actual voltage on the holding brake
$U_{BRAKE(8CVI)}$	Minimum voltage on the motor holding brake output of an 8CVI module
$R_{CAB(i)}$	Motor cable resistance for motor
$I_{BRAKE(i)}$	max. permitted current for holding brake i
$R_{DaisyChain}$	Resistance in the ACOPOSmotor 8DI
$R_{8CVE}$	Resistance in the 8CVE connection box
$R_{HybridCable}$	Resistance in the 8CCH cable

## 5.3 ACOPOSmotor

### 5.3.1 Power supply

Power is supplied to ACOPOSmotor 8DI modules via the X3A connection.

#### Caution!

The power supply for ACOPOSmotor 8DI modules is only permitted to be provided via an ACOPOSmulti drive system (8BVE expansion module), the DC bus of an ACOPOS P3 8EI servo drive or a decentralized 8CVE connection box!

#### Warning!

ACOPOSmotor drive systems are suitable for power systems that can provide a maximum short-circuit current (SCCR) of  $65 \text{ kA}_{\text{RMS}}$  at  $480 \text{ V}_{\text{RMS}}$  and that are protected with class RK5, J and CC fuses.

#### Warning!

ACOPOSmulti drive systems are equipped with integrated semiconductor short circuit protection. This semiconductor short circuit protection does not provide protection for branch circuits. Short circuit protection for branch circuits must be implemented in accordance with national directives or other local regulations.

#### Warning!

The opening of the branch-circuit protective device may be an indication that a fault current has been interrupted. To reduce the risk of fire or electric shock, current-carrying parts and other components of the controller should be examined and replaced if damaged. If burnout of the current element of an overload relay occurs, the complete overload relay must be replaced.

### 5.3.2 Protective ground connection

The following information concerning the protective ground connection corresponds to section "Connection elements for the protective ground conductor" in IEC 61800-5-1 and must be observed.

A protective ground conductor must be connected to the 8DI ACOPOSmotor module.

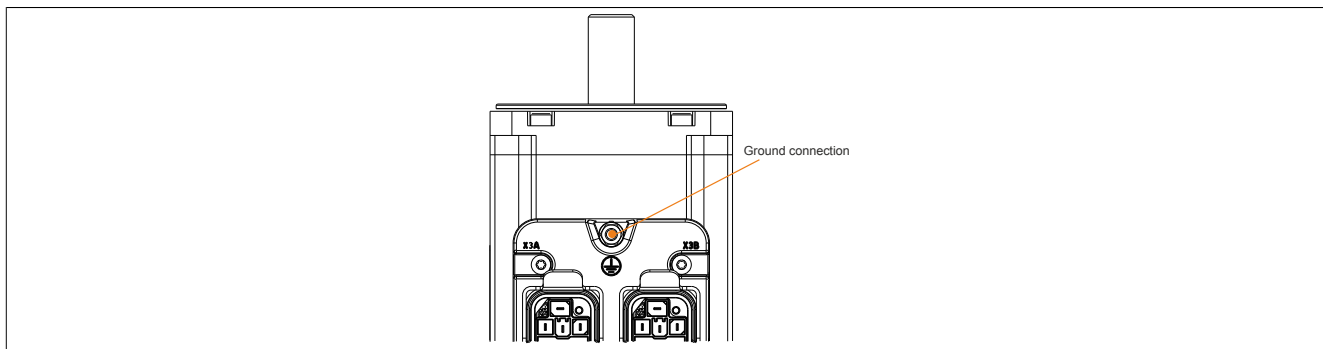

Figure 69: Protective ground connection

#### Line cross section

The line cross section of the protective ground conductor is oriented to the line conductors and must be selected according to the following table:

Line cross section for line conductor A [mm <sup>2</sup> ]	Minimum wire cross section for the protective ground connection A <sub>PE</sub> [mm <sup>2</sup> ] <sup>1)</sup>
A ≤ 16	A <sub>PE</sub> = A
16 < A ≤ 35	A <sub>PE</sub> = 16
35 < A	A <sub>PE</sub> = A / 2

Table 184: Selecting the cross section of the protective ground conductor

1) Any protective ground conductor that is not part of a cable must have a minimum wire cross section of 4 mm<sup>2</sup>.

### 5.3.3 Connecting ACOPOSmotor 8DI modules to an ACOPOSmulti drive system

#### Warning!

The DC power supply fuse protection of the ACOPOSmotor modules is only permitted to be fused in the 8BVE expansion module using fuses 50 201 06.50 or 50 11806.20 from SIBA.

#### 5.3.3.1 Procedure

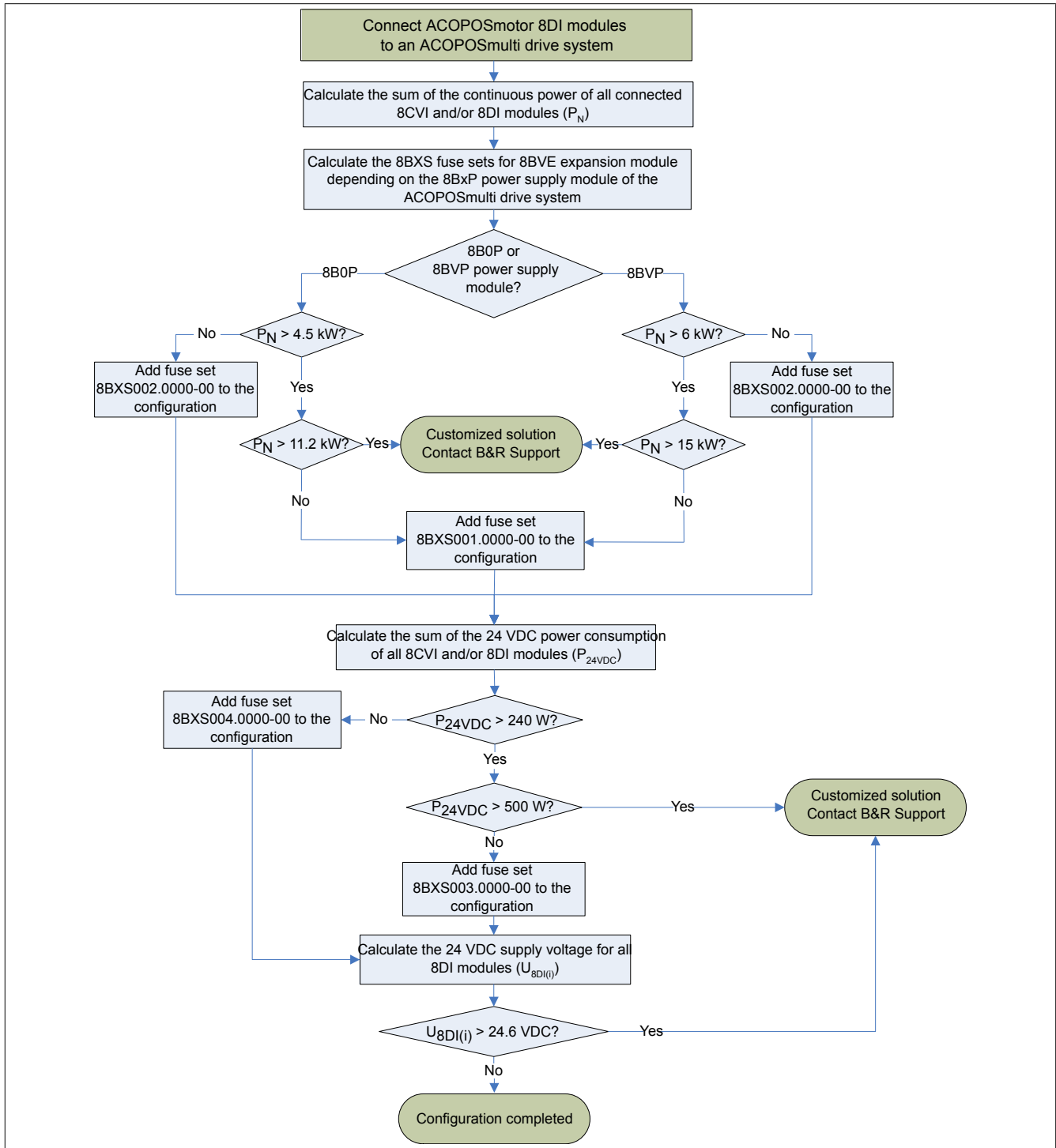
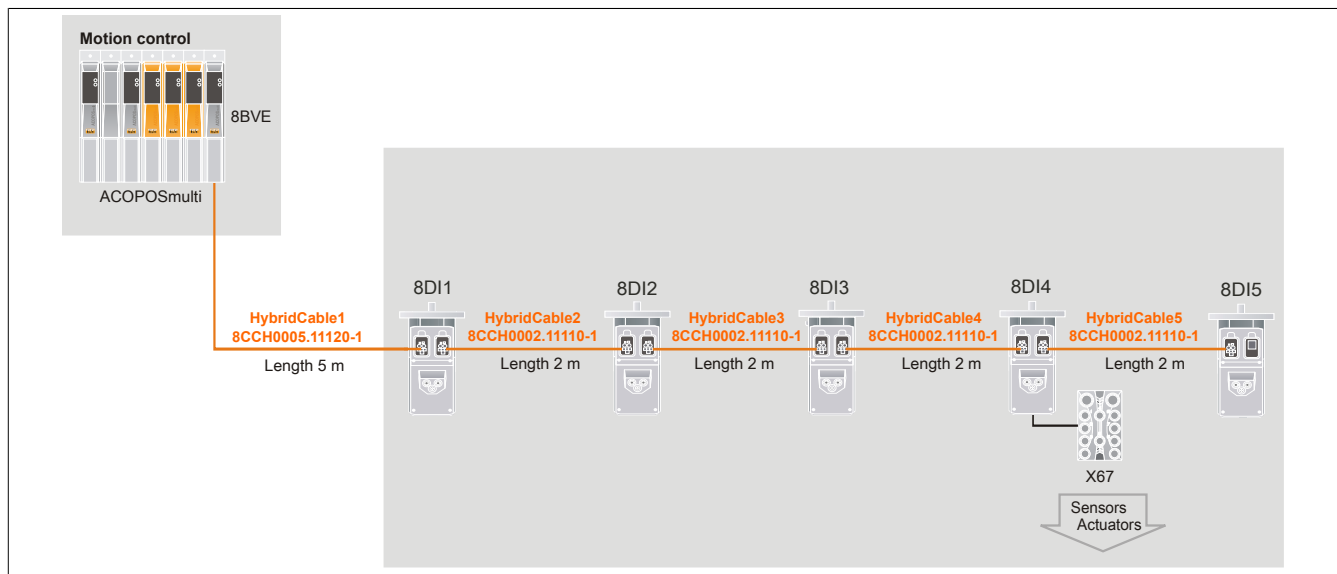

Figure 70: Procedure for connecting ACOPOSmotor 8DI modules to an ACOPOSmulti drive system

### 5.3.3.2 Example

The following ACOPOSmotor 8DI modules should be connected to an ACOPOSmulti drive system:

- 4 x 8DI330.D90457300-1
- 1 x 8DI330.D90457300-1 with connected 24 VDC consumer (1x X67DM9321.L12: 24 VDC power consumption 12 W)



#### 5.3.3.2.1 Calculation

##### Step 1) Determine total continuous consumption of all connected 8DI modules ( $P_N$ )

The continuous power per module is 1.5 kW.

$$P_N = 5 \times 1.5 \text{ kW} = 7.5 \text{ kW}$$

- ⇒ The sum of the continuous power of all modules ( $P_N$ ) is lower than the upper limit of 11.2 kW or 15 kW (depending on the selected power supply module). These modules can be connected to the ACOPOSmulti drive system.
- ⇒ Select the fuse set for the 8BVE expansion module based on the continuous power of all modules and the selected power supply module (8B0P or 8BVP) according to "[Procedure for connecting ACOPOSmotor 8DI modules to an ACOPOSmulti drive system](#)" on page 274. Fuse set 8BXS001.0000-00 must be chosen in this example.

**Step 2) Determine the total 24 VDC power consumption of all 8DI modules ( $P_{24VDC}$ )**

ACOPOSmotor modules		Quantity	Calculation of the 24 VDC power consumption
8DI1	8DI330.D90457300-1	1	$10 \text{ W} + P_{\text{holding brake}} + P_{24 \text{ VDC Out } 1} [0 \dots 96 \text{ W}] + P_{24 \text{ VDC Out } 2} [0 \dots 12 \text{ W}]$ $= 10 \text{ W} + 0 \text{ W} + 0 \text{ W} + 0 \text{ W}$ $= 10 \text{ W}$
8DI2	8DI330.D90457300-1	1	$10 \text{ W} + P_{\text{holding brake}} + P_{24 \text{ VDC Out } 1} [0 \dots 96 \text{ W}] + P_{24 \text{ VDC Out } 2} [0 \dots 12 \text{ W}]$ $= 10 \text{ W} + 0 \text{ W} + 0 \text{ W} + 0 \text{ W}$ $= 10 \text{ W}$
8DI3	8DI330.D90457300-1	1	$10 \text{ W} + P_{\text{holding brake}} + P_{24 \text{ VDC Out } 1} [0 \dots 96 \text{ W}] + P_{24 \text{ VDC Out } 2} [0 \dots 12 \text{ W}]$ $= 10 \text{ W} + 0 \text{ W} + 0 \text{ W} + 0 \text{ W}$ $= 10 \text{ W}$
8DI4	8DI330.D90457300-1 incl. 24 VDC consumer	1	$10 \text{ W} + P_{\text{holding brake}} + P_{24 \text{ VDC Out } 1} [0 \dots 96 \text{ W}] + P_{24 \text{ VDC Out } 2} [0 \dots 12 \text{ W}]$ $= 10 \text{ W} + 0 \text{ W} + 75 \text{ W} + 0 \text{ W}$ $= 85 \text{ W}$
8DI5	8DI330.D90457300-1	1	$10 \text{ W} + P_{\text{holding brake}} + P_{24 \text{ VDC Out } 1} [0 \dots 96 \text{ W}] + P_{24 \text{ VDC Out } 2} [0 \dots 12 \text{ W}]$ $= 10 \text{ W} + 0 \text{ W} + 0 \text{ W} + 0 \text{ W}$ $= 10 \text{ W}$
<b>Total of the 24 VDC power consumption <math>P_{24VDC}</math></b>			<b>= 125 W</b>

- ⇒ The sum of the 24 VDC power consumption of all modules ( $P_{24VDC}$ ) is less than the upper limit of 500 W. These modules can therefore be connected to the ACOPOSmulti drive system.
- ⇒ Select the fuse set for the 8BVE expansion module depending on the sum of the 24 VDC power consumptions of all modules according to the "[Procedure for connecting ACOPOSmotor 8DI modules to an ACOPOSmulti drive system](#)" on page 274. In this example, the sum of the 24 VDC power consumptions of all modules is <240 W, therefore the 8BXS004.0000-00 fuse set must be selected.

**Step 3) Calculation of the 24 VDC internal supply voltage at the 8BVE expansion module ( $U_{24VDC1calc}$ )**

To ensure functioning of the drive system, make sure that the minimum voltage of 18 V is maintained on the last module of the drive system. As an estimate, a voltage of at least 18 V is assumed in the calculation for the last module. By using the available power consumption values and the cable resistances in the calculation, it is possible to calculate back to a supply voltage of  $U_{24VDC1calc}$ . This calculated voltage must then be compared to the minimum permitted voltage of 24.6 V (25 V - 1.6%):

$U_{24VDC1calc} < 24.6 \text{ V (25 V - 1.6\%)} \dots$  Dimensioning in order

$U_{24VDC1calc} > 24.6 \text{ V (25 V - 1.6\%)} \dots$  Voltage drop in drive system is too high

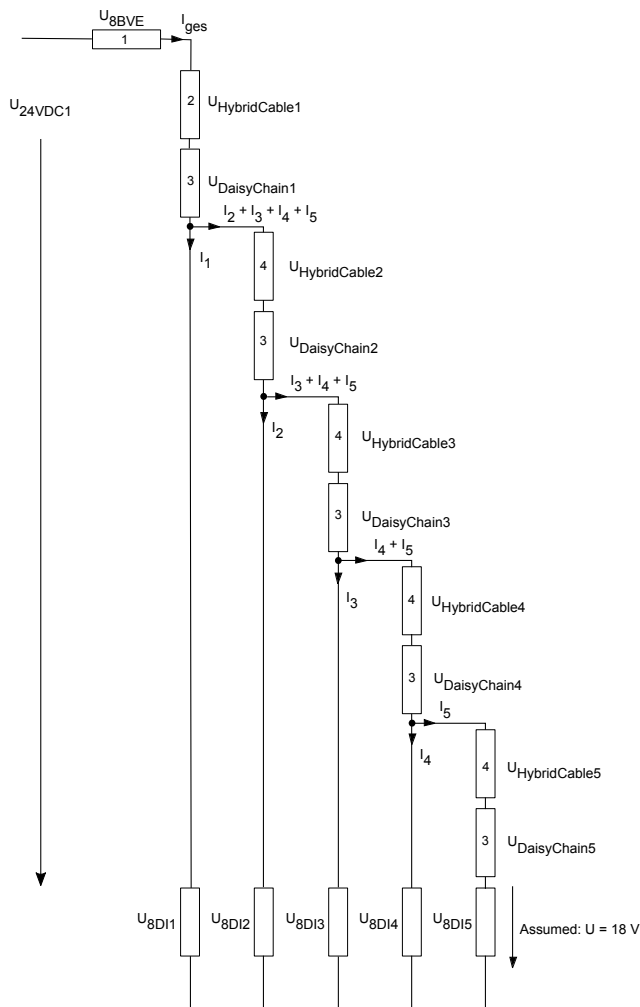

$$I_5 = \frac{P_5}{U} = \frac{10W}{18V} = 0.555A$$

$$U_{Daisychain5} = 0.007\Omega \cdot I_5 = 0.007\Omega \cdot 0.555A = 0.004V$$

$$U_{Hybridcable5} = 0.031\Omega \cdot I_5 = 0.031\Omega \cdot 0.555A = 0.017V$$

$$U_{8DI5} = 18V + U_{Daisychain5} + U_{Hybridcable5} = 18V + 0.004V + 0.017V = 18.02V$$

$$I_4 = \frac{P_4}{U_{8DI5}} = \frac{85W}{18.02V} = 4.717A$$

$$U_{Daisychain4} = 0.007\Omega \cdot (I_4 + I_5) = 0.007\Omega \cdot (4.717A + 0.555A) = 0.037V$$

$$U_{Hybridcable4} = 0.031\Omega \cdot (I_4 + I_5) = 0.031\Omega \cdot (4.717A + 0.555A) = 0.163V$$

$$U_{8DI4} = 18.02V + U_{Daisychain4} + U_{Hybridcable4} = 18.02V + 0.037V + 0.163V = 18.22V$$

$$I_3 = \frac{P_3}{U_{8DI4}} = \frac{30W}{18.22V} = 0.549A$$

$$U_{Daisychain3} = 0.007\Omega \cdot (I_3 + I_4 + I_5) = 0.007\Omega \cdot (0.549A + 4.717A + 0.555A) = 0.041V$$

$$U_{Hybridcable3} = 0.031\Omega \cdot (I_3 + I_4 + I_5) = 0.031\Omega \cdot (0.549A + 4.717A + 0.555A) = 0.18V$$

$$U_{8DI3} = 18.22V + U_{Daisychain3} + U_{Hybridcable3} = 18.22V + 0.041V + 0.18V = 18.44V$$

$$I_2 = \frac{P_2}{U_{8DI3}} = \frac{10W}{18.44V} = 0.542A$$

$$U_{Daisychain2} = 0.007\Omega \cdot (I_2 + I_3 + I_4 + I_5) = 0.007\Omega \cdot (0.542A + 0.549A + 4.717A + 0.555A) = 0.045V$$

$$U_{Hybridcable2} = 0.031\Omega \cdot (I_2 + I_3 + I_4 + I_5) = 0.031\Omega \cdot (0.542A + 0.549A + 4.717A + 0.555A) = 0.197V$$

$$U_{8DI2} = 18.44V + U_{Daisychain2} + U_{Hybridcable2} = 18.44V + 0.045V + 0.197V = 18.683V$$

$$I_1 = \frac{P_1}{U_{8DI2}} = \frac{10W}{18.683V} = 0.535A$$

$$U_{Daisychain1} = 0.007\Omega \cdot (I_1 + I_2 + I_3 + I_4 + I_5) = 0.007\Omega \cdot (0.535A + 0.542A + 0.549A + 4.717A + 0.555A) = 0.048V$$

$$U_{Hybridcable1} = 0.078\Omega \cdot (I_1 + I_2 + I_3 + I_4 + I_5) = 0.078\Omega \cdot (0.535A + 0.542A + 0.549A + 4.717A + 0.555A) = 0.538V$$

$$U_{8BVE} = 0.029\Omega \cdot (I_1 + I_2 + I_3 + I_4 + I_5) = 0.029\Omega \cdot (0.535A + 0.542A + 0.549A + 4.717A + 0.555A) = 0.20V$$

$$U_{24VDC1calc} = 19.35V + U_{Daisychain1} + U_{Hybridcable1} + U_{8BVE} = 18.683V + 0.048V + 0.538V + 0.20V = 19.469V$$

Figure 71: ACOPOS motor drive system - Equivalent circuit diagram

- (3)  $R_{DaisyChain} \dots 0.007 \Omega$
- (1)  $R_{8BVE} \dots 0.029 \Omega$
- (2)  $R_{HybridCable1} \dots 0.078 \Omega$
- (4)  $R_{HybridCable2-5} \dots 0.02 \Omega$

⇒ Result:  $U_{24VDC1calc} < 24.6 V$  (25 V - 1.6%)

These 8DI modules can therefore be connected to the ACOPOS multi drive system.

Formula symbols used

Symbol	Name
$P_{24VDC}$	Total power
$P_N$	Total of all continuous power consumption of all the 8DI modules
$P_{1...5}$	24 VDC power consumption of the ACOPOS motor 8DI
$U_{24VDC}$	+24 VDC internal system voltage supply of the ACOPOS motor drive system
$U_{24VDC1min}$	minimum permitted system voltage of 24.6 V (25 V - 1.6%)
$U_{24VDC1calc}$	Calculated +24 VDC internal system voltage supply at the 8BVE expansion module
$U_{8DI1...5}$	+24 VDC voltage in the ACOPOS motor 8DI
$U_{8BVE}$	Internal 24 VDC voltage drop in the 8BVE expansion module
$U_{Hybrid cable1...5}$	Internal 24 VDC voltage drop in the 8CCH cable
$U_{Daisychain(i)}$	Internal 24 VDC voltage in the ACOPOS motor 8DI
$R_{DaisyChain}$	Resistance in the ACOPOS motor 8DI
$R_{8BVE}$	Resistance in the 8BVE expansion module
$R_{HybridCable}$	Conductor resistance of power conductors in the 8CCH cable

### 5.3.4 Connecting ACOPOSmotor 8DI to an ACOPOS P3 drive system

#### 5.3.4.1 Procedure

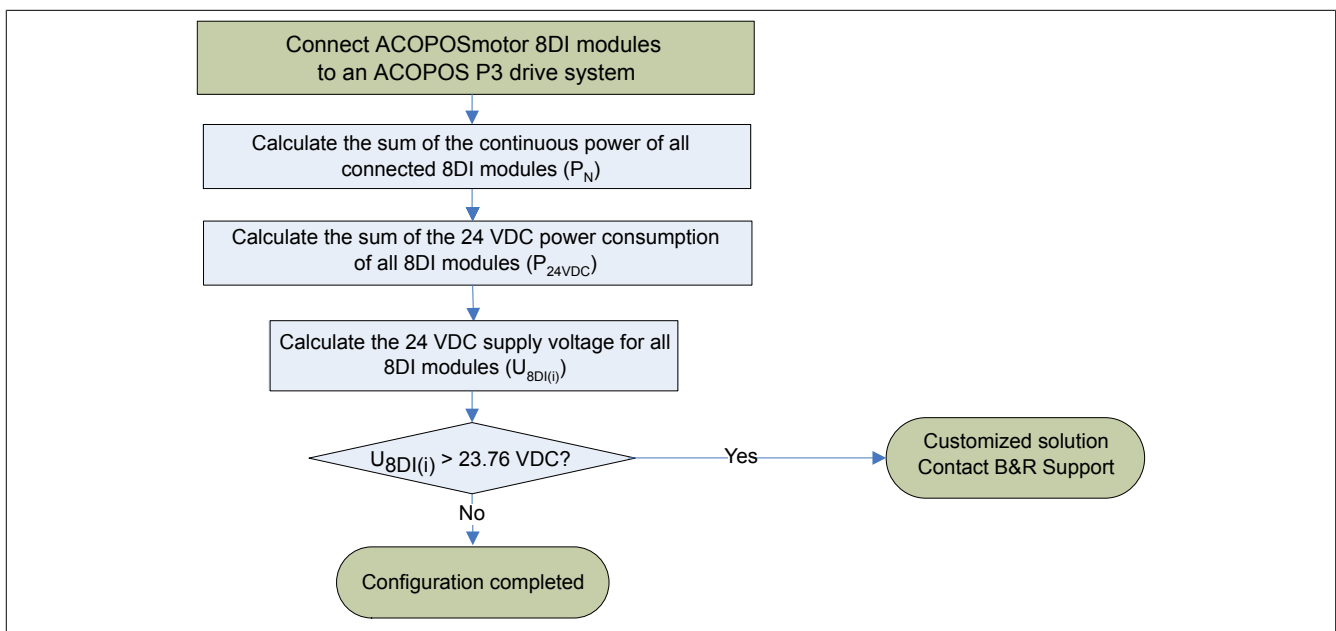
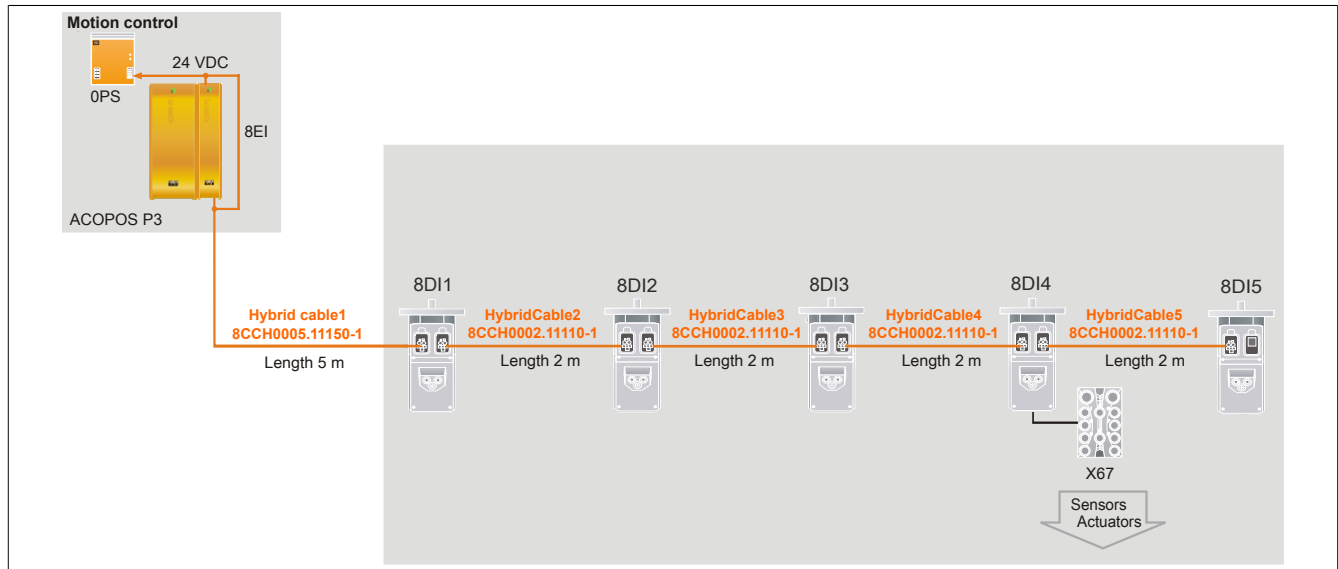

Figure 72: Procedure for connecting ACOPOSmotor 8DI modules to an ACOPOS P3 drive system

### 5.3.4.2 Example

The following ACOPOSmotor 8DI modules should be connected to an ACOPOS P3 drive system:

- 4 x 8DI330.D90457300-1
- 1 x 8DI330.D90457300-1 with connected 24 VDC consumer (1x X67DM9321.L12: 24 VDC power consumption 75 W)
- Power supply unit 24 VDC 0PS3200.1, max. output power 480 W
- 1 x 8EI2X2HWT10.XXXX-1, self-consumption 24 VDC



#### 5.3.4.2.1 Calculation

**Step 1) Calculate the sum of the continuous power consumption of all connected 8DI / 8EI modules ( $P_N$ )**

The continuous power is 0.59 kW for each 8DI module.

$$P_N = 5 \times 0.59 \text{ kW} = \mathbf{2.95 \text{ kW}}$$

**Step 2) Calculate the sum of the 24 VDC power consumption of all 8DI modules ( $P_{24VDC}$ )**

ACOPOSmotor modules		Quantity	Calculation of the 24 VDC power consumption
8DI1	8DI330.D90457300-1	1	$10 \text{ W} + P_{\text{HoldingBrake}} + P_{24 \text{ VDC Out 1}} [0 \dots 96 \text{ W}] + P_{24 \text{ VDC Out 2}} [0 \dots 12 \text{ W}]$ $= 10 \text{ W} + 0 \text{ W} + 0 \text{ W} + 0 \text{ W}$ $= 10 \text{ W}$
8DI2	8DI330.D90457300-1	1	$10 \text{ W} + P_{\text{HoldingBrake}} + P_{24 \text{ VDC Out 1}} [0 \dots 96 \text{ W}] + P_{24 \text{ VDC Out 2}} [0 \dots 12 \text{ W}]$ $= 10 \text{ W} + 0 \text{ W} + 0 \text{ W} + 0 \text{ W}$ $= 10 \text{ W}$
8DI3	8DI330.D90457300-1	1	$10 \text{ W} + P_{\text{HoldingBrake}} + P_{24 \text{ VDC Out 1}} [0 \dots 96 \text{ W}] + P_{24 \text{ VDC Out 2}} [0 \dots 12 \text{ W}]$ $= 10 \text{ W} + 0 \text{ W} + 0 \text{ W} + 0 \text{ W}$ $= 10 \text{ W}$
8DI4	8DI330.D90457300-1 including 24 VDC consumer	1	$10 \text{ W} + P_{\text{HoldingBrake}} + P_{24 \text{ VDC Out 1}} [0 \dots 96 \text{ W}] + P_{24 \text{ VDC Out 2}} [0 \dots 12 \text{ W}]$ $= 10 \text{ W} + 0 \text{ W} + 75 \text{ W} + 0 \text{ W}$ $= 85 \text{ W}$
8DI5	8DI330.D90457300-1	1	$10 \text{ W} + P_{\text{HoldingBrake}} + P_{24 \text{ VDC Out 1}} [0 \dots 96 \text{ W}] + P_{24 \text{ VDC Out 2}} [0 \dots 12 \text{ W}]$ $= 10 \text{ W} + 0 \text{ W} + 0 \text{ W} + 0 \text{ W}$ $= 10 \text{ W}$
ACOPOS P3 modules			
8EI	8EI2X2HWT10.XXXX-1	1	$P_{\text{HoldingBrake}} + P_{24 \text{ VDC,8EI}}$ $= 0 \text{ W} + 1.2 \text{ A} \cdot 24 \text{ VDC}$ $= 28.8 \text{ W}$
<b>Sum of the 24 VDC power consumption <math>P_{24VDC}</math></b>			<b>= 153.8 W</b>

⇒ The sum of the 24 VDC power consumption of all modules ( $P_{24VDC}$ ) is less than the upper limit of 480 W.

**Step 3) Calculate the 24 VDC internal supply voltage  $U_{24VDC1calc}$**

The minimum voltage of 18 V must be maintained on the last module of the drive system to ensure that the drive system functions properly. For an estimation, voltage of 18 V is assumed on the last module for the calculation. By calculating using the existing power consumption and cable resistances, it is possible to calculate back to a supply voltage of  $U_{24VDC1calc}$ . This calculated voltage must then be compared with the minimum required output voltage of power supply unit OPS3200 23.76 V (24 V - 1%):

$U_{24VDC1calc} < 23.76 \text{ V (24 V - 1\%)} \dots$  Dimensioning OK

$U_{24VDC1calc} > 23.76 \text{ V (24 V - 1\%)} \dots$  Voltage drop in the drive system too high

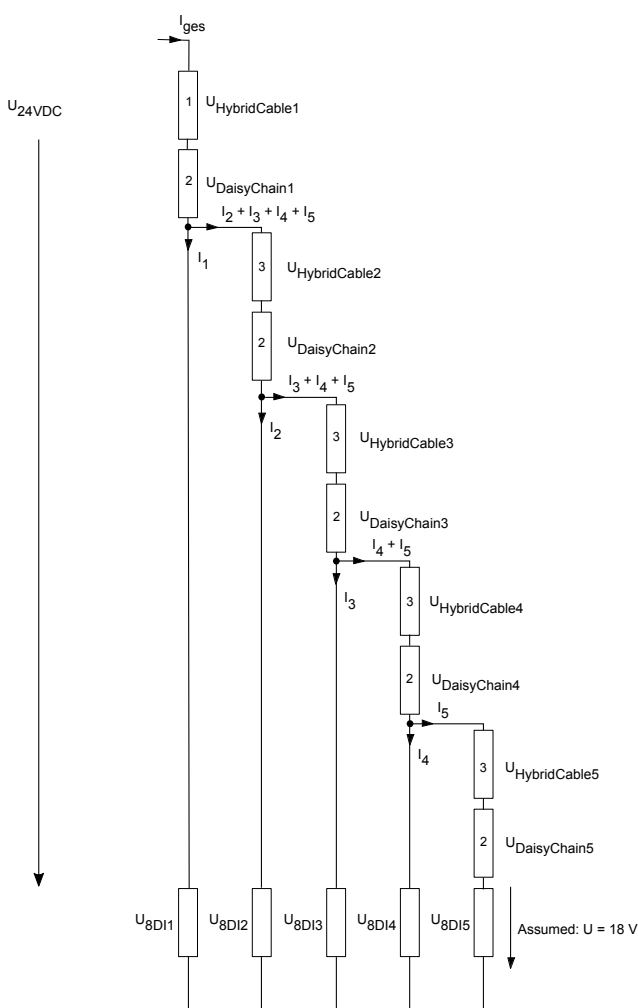

$$I_5 = \frac{P_5}{U} = \frac{10W}{18V} = 0.555A$$

$$U_{DaisyChain5} = 0.007\Omega \cdot I_5 = 0.007\Omega \cdot 0.555A = 0.004V$$

$$U_{HybridKabel5} = 0.031\Omega \cdot I_5 = 0.031\Omega \cdot 0.555A = 0.017V$$

$$U_{8DI5} = 18V + U_{DaisyChain5} + U_{HybridKabel5} = 18V + 0.004V + 0.017V = 18.02V$$

$$I_4 = \frac{P_4}{U_{8DI5}} = \frac{85W}{18.02V} = 4.717A$$

$$U_{DaisyChain4} = 0.007\Omega \cdot (I_4 + I_5) = 0.007\Omega \cdot (4.717A + 0.555A) = 0.037V$$

$$U_{HybridKabel4} = 0.031\Omega \cdot (I_4 + I_5) = 0.031\Omega \cdot (4.717A + 0.555A) = 0.163V$$

$$U_{8DI4} = 18.02V + U_{DaisyChain4} + U_{HybridKabel4} = 18.02V + 0.037V + 0.163V = 18.22V$$

$$I_3 = \frac{P_3}{U_{8DI4}} = \frac{10W}{18.42V} = 0.549A$$

$$U_{DaisyChain3} = 0.007\Omega \cdot (I_3 + I_4 + I_5) = 0.007\Omega \cdot (0.549A + 4.717A + 0.555A) = 0.041V$$

$$U_{HybridKabel3} = 0.031\Omega \cdot (I_3 + I_4 + I_5) = 0.031\Omega \cdot (0.549A + 4.717A + 0.555A) = 0.18V$$

$$U_{8DI3} = 18.22V + U_{DaisyChain3} + U_{HybridKabel3} = 18.22V + 0.041V + 0.18V = 18.441V$$

$$I_2 = \frac{P_2}{U_{8DI3}} = \frac{10W}{18.441V} = 0.542A$$

$$U_{DaisyChain2} = 0.007\Omega \cdot (I_2 + I_3 + I_4 + I_5) = 0.007\Omega \cdot (0.542A + 0.549A + 4.717A + 0.555A) = 0.045V$$

$$U_{HybridKabel2} = 0.031\Omega \cdot (I_2 + I_3 + I_4 + I_5) = 0.031\Omega \cdot (0.542A + 0.549A + 4.717A + 0.555A) = 0.197V$$

$$U_{8DI2} = 18.44V + U_{DaisyChain2} + U_{HybridKabel2} = 18.441V + 0.045V + 0.197V = 18.683V$$

$$I_1 = \frac{P_1}{U_{8DI2}} = \frac{10W}{18.683V} = 0.535A$$

$$U_{DaisyChain1} = 0.007\Omega \cdot (I_1 + I_2 + I_3 + I_4 + I_5) = 0.007\Omega \cdot (0.535A + 0.542A + 0.549A + 4.717A + 0.555A) = 0.048V$$

$$U_{HybridKabel1} = 0.078\Omega \cdot (I_1 + I_2 + I_3 + I_4 + I_5) = 0.078\Omega \cdot (0.535A + 0.542A + 0.549A + 4.717A + 0.555A) = 0.538V$$

$$U_{24VDC1calc} = 18.683V + U_{DaisyChain1} + U_{HybridKabel1} = 18.683V + 0.048V + 0.538V + 0.20V = 19.469V$$

Figure 73: ACOPOSmotor drive system - Equivalent circuit diagram

- (2)  $R_{DaisyChain} \dots 0.007 \Omega$
- (1)  $R_{HybridCable1} \dots 0.078 \Omega$
- (3)  $R_{HybridCable2-5} \dots 0.031 \Omega$

⇒ Result:  $U_{24VDC1calc} < 23.76 \text{ V (24 V - 1\%)}$

These 8DI modules can therefore be connected to the ACOPOS P3 drive system.

**Formula symbols used**

Symbol	Name
$P_{24VDC}$	Total power
$P_N$	Sum of the continuous power of all 8DI modules
$P_{1...5}$	24 VDC power consumption of the ACOPOSmotor 8DI
$U_{24VDC}$	+24 VDC internal system power supply of the ACOPOSmotor drive system
$U_{24VDC1calc}$	Calculated minimum required voltage on the +24 VDC connector of the ACOPOS P3
$U_{8DI1...5}$	+24 VDC voltage in the ACOPOSmotor 8DI
$U_{HybridCable1...5}$	Internal 24 VDC voltage drop in the 8CCH cable
$U_{DaisyChain(i)}$	Internal 24 VDC voltage drop in the ACOPOSmotor 8DI
$R_{DaisyChain}$	Resistance in the ACOPOSmotor 8DI
$R_{HybridCable}$	Conductor resistance of power conductors in the 8CCH cable

## 5.4 ACOPOSmotor Compact

### 5.4.1 Power supply

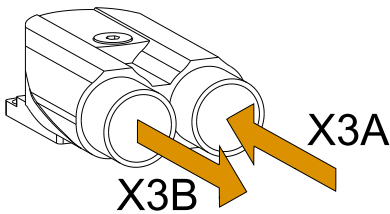

The power supply of ACOPOSmotor Compact modules (8D1) is provided via the X3A connection.

#### Information:

The permissible supply voltage for ACOPOSmotor Compact 8D1 modules is 24 to 58 VDC.

#### Warning!

The maximum current-carrying capacity of the power contacts of the 9-pin hybrid connector (connection X3A) is 20 A at 40°C.

#### Warning!

Fuse protection of the ACOPOSmotor Compact power supply cable must take place in accordance with the national regulations for the installation location.

#### 5.4.1.1 Power supply unit

The power supply unit must be certified and meet the following requirements:

- Galvanic isolation between input and output
- Max. permissible output voltage: 24 to 58 VDC
- Overvoltage protection max. 60 VDC (also against internal overvoltages)
- Max. permissible output current: 60 A
- Fuse protection output: DC fuse or circuit breaker with max. 35 A
- Output protective measures: No-load proof, overload-proof, continuous short circuit protection and feedback protection
- The power supply unit must have UL certification for the USA.

#### Information:

ACOPOSmulti auxiliary supply module 8B0C0320Hx00.B00-1 meets these requirements. Output fuse protection is not necessary since 8B0C0320Hx00.B00-1 has module-internal current limitation.

### 5.4.2 Fuse protection of the power supply cable

Due to the daisy-chain connection, there is a risk that upstream devices may be damaged in the event of a fault at the end of the connection (e.g. short circuit, defective wiring). For the power connection (DC+ and DC-), this is prevented by an overload and short-circuit shutdown of the supplying module.

#### Information:

It is recommended that the STO circuit be protected accordingly.

- A max. operating current of 6 mA is expected per connected device.
- The maximum permissible current in the STO line is not permitted to permanently exceed 500 mA.
- The fuse component used must be suitable for DC and have a breaking capacity corresponding to the voltage source.

### 5.4.3 Procedure for sizing the DC bus

The dimensioning examples presented in this section are intended to provide a rough estimate of the application sizing based on the power balance of the individual modules for a static operating point. This does not allow a detailed sizing of dynamic operating cycles since this depends on other factors such as the cable lengths used between modules.

The power consumption on the DC bus of an ACOPOSmotor Compact module can be calculated as follows depending on the order option and the static operating point ( $n > 0$ ):

$$P = P_{\text{mech}} / 0.85 + P_{\text{On}} \text{ (optional)} + P_{24\text{VDC,Out}} \text{ (optional)} + 10 \text{ W}$$

$$P_{\text{mech}} = \omega \cdot M = 2\pi \cdot n \text{ [rpm]} / 60 \text{ s} \cdot M$$

**Maximum permissible power on the DC bus** at 40°C ambient temperature and supply voltage of 58 V:

$$P_{\text{DC bus}} = U_{\text{DC bus}} \cdot I_{\text{DC bus,max}} = 58 \text{ VDC} \cdot 20 \text{ A} = \mathbf{1.16 \text{ kW}}$$

At lower supply voltages, the power on the DC bus is also reduced accordingly.

#### Formula symbols used

Symbol	Name
$P_x$	Power requirements [W] of the ACOPOSmotor Compact module
$P_{\text{mech}}$	Mechanical power [W] on the motor shaft
$P_{\text{On}}$	Connection power [W] of the holding brake
$P_{24\text{VDC,Out}}$	Maximum power consumption [W] of the 24 VDC output
$\omega$	Angular velocity
$M$	Torque [Nm]
$n$	Speed [rpm]
$P_{\text{DC bus}}$	Permissible power [W] on the DC bus
$U_{\text{DC bus}}$	DC bus voltage [V]
$I_{\text{DC bus,max}}$	Maximum permissible DC bus current [A]
$P_{\text{sum}}$	Total power [W] of the ACOPOSmotor Compact modules on a daisy-chain segment

### 5.4.3.1 Dimensioning example 1

This dimensioning example assumes simultaneous daisy-chain operation of three ACOPOSmotor Compact modules ( $U_{DC\ bus} = 54\ V$ ).

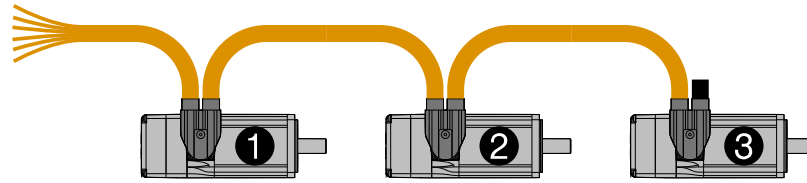

ACOPOSmotor Compact			
	Module 1	Module 2	Module 3
Order code	8D1A22.HI2000000-1	8D1A23.AD0000000-1	8D1A23.HH2000000-1
Size	2		
Gearbox	No		
Electronics option	Yes	No	Yes
Holding brake	Yes	No	Yes
Speed [rpm]	2,500	1,750	3,200
Torque [Nm]	0.49	0.95	0.35

#### Calculation of power consumption ( $P_x$ ):

**Module 1**

$$P_{mech1} = 2\pi \cdot 2500 / 60\ s \cdot 0.49\ Nm = 128\ W$$

$$P_1 = 128\ W / 0.85 + 8.4\ W + 7\ W + 10\ W = \mathbf{176\ W}$$

**Module 2**

$$P_{mech2} = 2\pi \cdot 1750 / 60\ s \cdot 0.95\ Nm = 174\ W$$

$$P_2 = 174\ W / 0.85 + 10\ W = \mathbf{215\ W}$$

**Module 3**

$$P_{mech3} = 2\pi \cdot 1200 / 60\ s \cdot 0.95\ Nm = 117\ W$$

$$P_3 = 117\ W / 0.85 + 8.4\ W + 7\ W + 10\ W = \mathbf{163\ W}$$

The total power ( $P_{sum}$ ) of the three modules is therefore as follows:

$$P_{sum} = P_1 + P_2 + P_3 = 176\ W + 215\ W + 163\ W = \mathbf{554\ W} < 54\ V \cdot 20\ A = 1.08\ kW$$

Since the total power ( $P_{sum}$ ) of the three modules does not exceed the maximum DC bus voltage ( $P_{DC\ bus}$ ) at the considered operating point, static operation is possible in principle in this configuration.

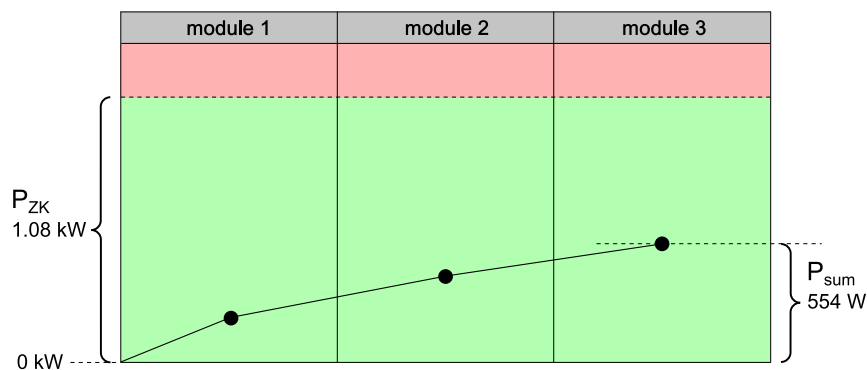
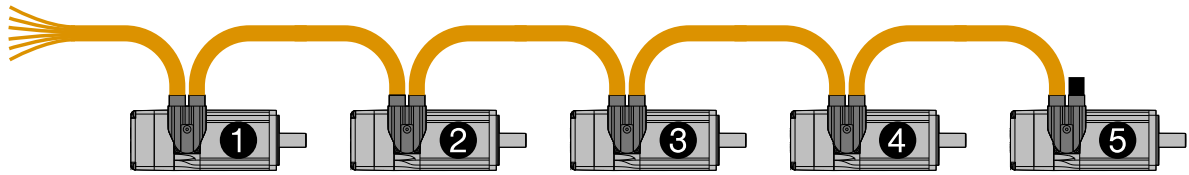

Figure 74: Performance diagram for dimensioning example 1

### 5.4.3.2 Dimensioning example 2

This dimensioning example assumes simultaneous daisy-chain operation of five ACOPOSmotor Compact modules ( $U_{DC\ bus} = 58\ V$ ).



ACOPOSmotor Compact						
	Module 1	Module 2	Module 3	Module 4	Module 5	
Order code	8D1A23.HH0000000-1	8D1A23.BH2000000-1	8D1A22.BI0000000-1	8D1A23.HD0000000-1	8D1A23.HB2000000-1	
Size	2					
Gearbox	No					
Electronics option	Yes	No			Yes	
Holding brake	No	Yes	No		Yes	
Speed [rpm]	3,950	2,700	3,750	1,650	1,200	
Torque [Nm]	0.65	0.75	0.45	1.00	0.85	

#### Calculation of power consumption ( $P_x$ ):

**Module 1**  $P_{mech1} = 2\pi \cdot 3950 / 60\ s \cdot 0.65\ Nm = 269\ W$

$P_1 = 269\ W / 0.85 + 7\ W + 10\ W = \mathbf{333\ W}$

**Module 2**  $P_{mech2} = 2\pi \cdot 2700 / 60\ s \cdot 0.75\ Nm = 212\ W$

$P_2 = 212\ W / 0.85 + 8.4\ W + 10\ W = \mathbf{268\ W}$

**Module 3**  $P_{mech3} = 2\pi \cdot 3750 / 60\ s \cdot 0.45\ Nm = 177\ W$

$P_3 = 177\ W / 0.85 + 10\ W = \mathbf{218\ W}$

**Module 4**  $P_{mech4} = 2\pi \cdot 1650 / 60\ s \cdot 1.00\ Nm = 173\ W$

$P_4 = 173\ W / 0.85 + 7\ W + 10\ W = \mathbf{221\ W}$

**Module 5**  $P_{mech5} = 2\pi \cdot 1200 / 60\ s \cdot 0.85\ Nm = 107\ W$

$P_5 = 107\ W / 0.85 + 8.4\ W + 7\ W + 10\ W = \mathbf{151\ W}$

#### The total power ( $P_{sum}$ ) of the five modules is therefore as follows:

$$P_{sum} = P_1 + P_2 + P_3 + P_4 + P_5 = 333\ W + 268\ W + 218\ W + 221\ W + 151\ W = \mathbf{1.19\ kW} > \mathbf{1.16\ kW}$$

Since the total power ( $P_{sum}$ ) of the five modules exceeds the maximum DC bus voltage ( $P_{DC\ bus}$ ) at the considered operating point, continuous operation is not possible in this configuration.

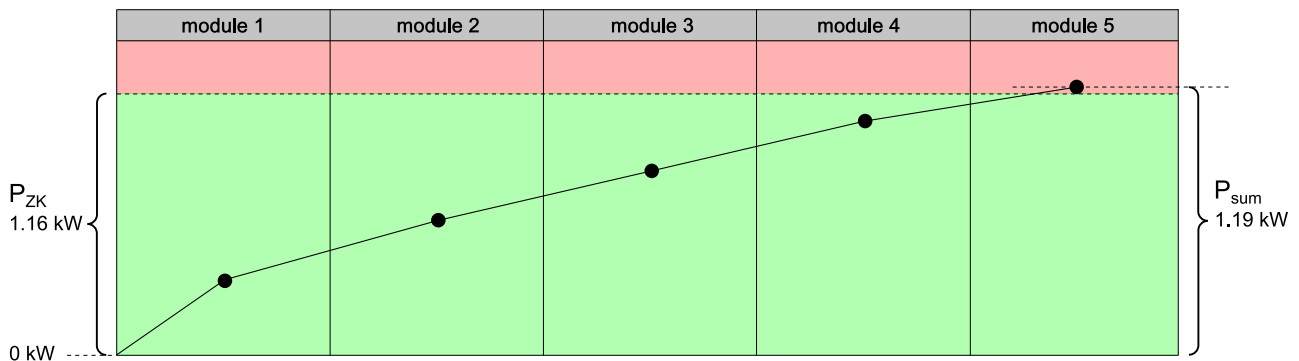

Figure 75: Performance diagram for dimensioning example 2

### 5.4.4 Procedure for sizing the STO power supply cable

The number of possible daisy-chain connections is limited by the STO power supply cable, for example.

#### Two factors play a role in this:

- The maximum current-carrying capacity of 500 mA is not permitted to be exceeded.
- The voltage drop is not permitted to cause the voltage at the last enable input to fall below 15 V.

#### Factor 1 - Maximum current-carrying capacity

The max. current-carrying capacity<sup>9)</sup> (**500 mA**) and max. enable input currents (5.5 or 6.0 mA) result in the following **limit of modules connected via daisy chain**:

**24 V enable input voltage** - Max. enable input current: 5.5 mA

$$n = 500 \text{ mA} / 5.5 \text{ mA} = 90$$

The maximum number of modules connected via daisy chain is 90.

**30 V enable input voltage** - Max. enable input current: 6.0 mA

$$n = 500 \text{ mA} / 6.0 \text{ mA} = 83$$

The maximum number of modules connected via daisy chain is 83.

#### Factor 2 - Voltage drop

The voltage drop factor must be calculated separately for each application. This can be done using the following equivalent circuit diagram and analogously to the following dimensioning examples.

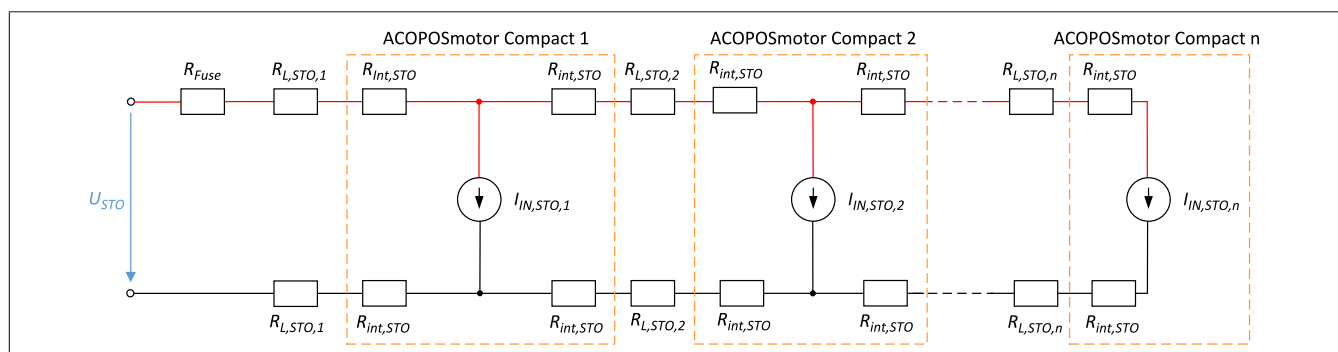

Figure 76: Equivalent circuit diagram

The calculation formulas are listed in the dimensioning examples.

#### The following data is available for complying with these conditions:

- Resistance of the STO line in the hybrid cable:  $R_L(T_{amb}) = R_L(T_0) \cdot (1 + \alpha \cdot (T_{amb} - T_0))$

$$\text{Where: } R_L(T_0) = \frac{\rho \cdot l}{A}$$

$$T_0 = 20^\circ \text{C}$$

$$\rho = 0.01786 \frac{\Omega \cdot \text{mm}^2}{\text{m}}$$

$$\alpha = 3.93 \cdot 10^{-3} \cdot 1 / ^\circ \text{C}$$

- The cross-sectional area of the enable stranded wires of offered hybrid cables is 0.34 mm<sup>2</sup>.
- Device-internal resistance in the STO path:  $R_{int} = 83.3 \text{ m}\Omega$

#### Formula symbols used

Symbol	Name
A	Cross-sectional area [mm <sup>2</sup> ]
$\alpha$	Temperature coefficient
$I_{FUSE}$	Fuse protection [mA] of the STO power supply cable
$I_{IN}$	Max. enable input current [A] at specific voltage
$I_{IN,STO,x}$	Current consumption [A] of the ACOPOSmotor Compact module
l	Line length [m]
n	Limit of modules connected via daisy chain
$\rho$	Specific resistance

<sup>9)</sup> If a fuse with  $I_{FUSE} < 500 \text{ mA}$  is used, this must be taken into account when calculating the limit on modules connected via daisy chain.

## Dimensioning

Symbol	Name
$R_{\text{FUSE}}$	Resistance [ $\Omega$ ] of the fuse being used
$R_{\text{int,STO}}$	Device-internal resistance [ $\Omega$ ] in the STO path
$R_{\text{L}}(T)$	Resistance [ $\Omega$ ] of the STO line in the hybrid cable depending on the ambient temperature
$R_{\text{L,STO,1m}}$	Max. cable resistance [ $\Omega$ ] per meter
$T_{\text{amb}}$	Ambient temperature [ $^{\circ}\text{C}$ ]
$T_0$	Reference temperature [ $^{\circ}\text{C}$ ]
$U_{\text{STO}}$	Voltage at the source [V]

### 5.4.4.1 Dimensioning example 1

This dimensioning example assumes simultaneous daisy-chain operation of three ACOPOSmotor Compact modules.

#### Assumptions:

- Fuse used:  $R_{Fuse} = 15 \Omega$
- Voltage at the source:  $U_{STO} = 24 \text{ V}$
- Current consumption:  $I_{IN,STO,1} = I_{IN,STO,2} = I_{IN,STO,3} = I_{IN} = 5.5 \text{ mA}$  (simplifying assumption)
- Ambient temperature:  $T_{amb} = 40^\circ\text{C}$

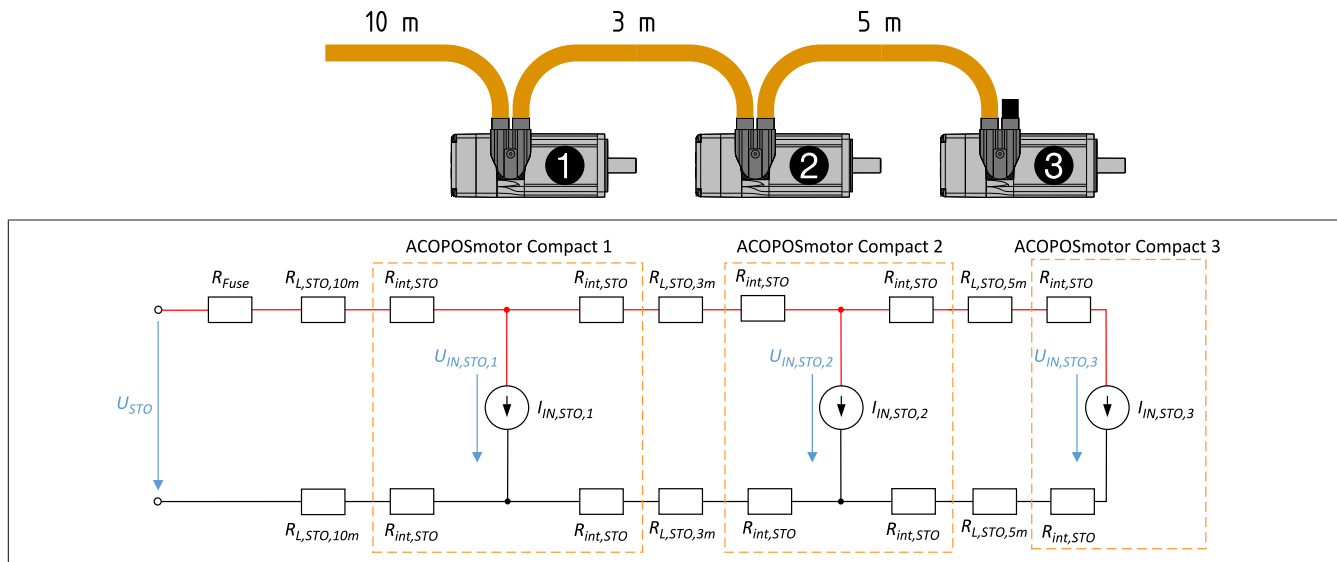

Figure 77: Equivalent circuit diagram for dimensioning example 1

#### Cable resistance calculation:

Maximum cable resistance per meter:

$$R_{L,STO,1m} = \frac{\rho \cdot l}{A} \cdot (1 + \alpha \cdot (T_{amb} - T_0)) = \frac{0.01786 \frac{\Omega \cdot \text{mm}^2}{\text{m}} \cdot 1\text{m}}{0.34\text{mm}^2} \cdot \left(1 + 3.93 \cdot 10^{-3} \cdot \frac{1}{\text{K}} \cdot (40 - 20)\text{K}\right) = 56.7 \text{ m}\Omega$$

#### Calculation of the voltages applied to the enable inputs:

##### 10 m cable

$$U_{IN,STO,1} = U_{STO} - 3 \cdot I_{IN} \cdot (R_{Fuse} + 2 \cdot R_{L,STO,10m} + 2 \cdot R_{int,STO}) = 24\text{V} - 3 \cdot 5.5\text{mA} \cdot (15\Omega + 20 \cdot 56.7\text{m}\Omega + 2 \cdot 83.3\text{m}\Omega) = 23.731 \text{ V}$$

##### 3 m cable

$$U_{IN,STO,2} = U_{IN,STO,1} - 2 \cdot I_{IN} \cdot (2 \cdot R_{L,STO,3m} + 4 \cdot R_{int,STO}) = 23.731\text{V} - 2 \cdot 5.5\text{mA} \cdot (2 \cdot 3 \cdot 56.7\text{m}\Omega + 4 \cdot 83.3\text{m}\Omega) = 23.724 \text{ V}$$

##### 5 m cable

$$U_{IN,STO,3} = U_{IN,STO,2} - I_{IN} \cdot (2 \cdot R_{L,STO,5m} + 4 \cdot R_{int,STO}) = 23.724\text{V} - 5.5\text{mA} \cdot (2 \cdot 5 \cdot 56.7\text{m}\Omega + 4 \cdot 83.3\text{m}\Omega) = 23.719 \text{ V}$$

Operation in this configuration is possible from the point of view of the enable signal because  $23.719 \text{ V} > 15 \text{ V}$ .

## 5.4.4.2 Dimensioning example 2

This dimensioning example assumes simultaneous daisy-chain operation of five ACOPOSmotor Compact modules.

**Assumptions:**

- Fuse used: None
- Voltage at the source:  $U_{STO} = 30\text{ V}$
- Current consumption:  $I_{IN,STO,1} = I_{IN,STO,2} = I_{IN,STO,3} = I_{IN,STO,4} = I_{IN,STO,5} = I_{IN} = 6.0\text{ mA}$  (simplifying assumption)
- Ambient temperature:  $T_{amb} = 20^\circ\text{C}$

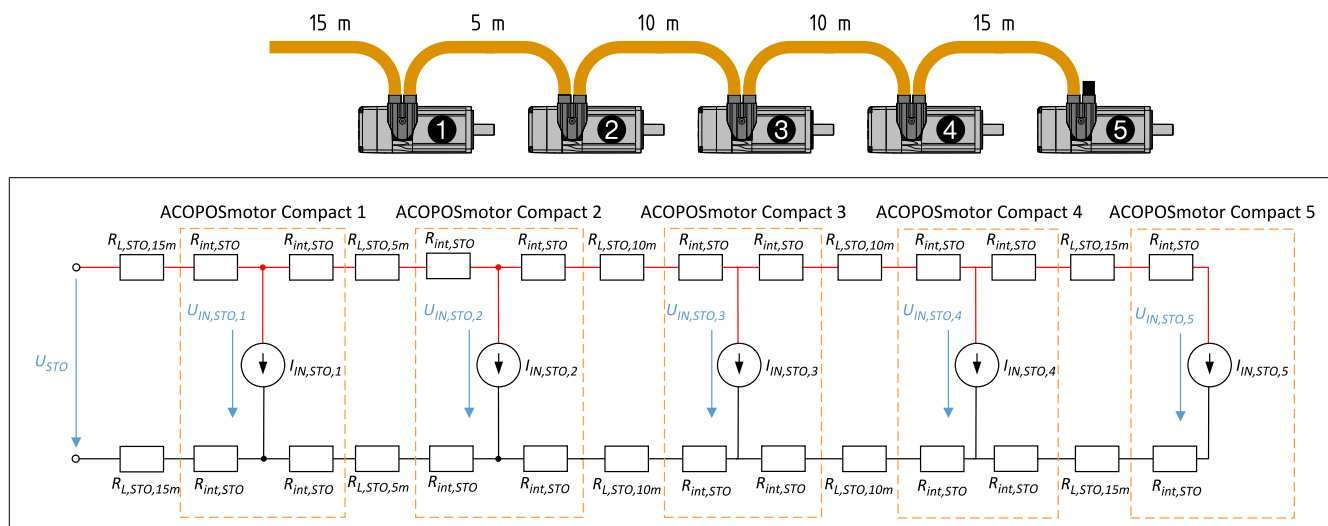

Figure 78: Equivalent circuit diagram for dimensioning example 2

**Cable resistance calculation:**

Maximum cable resistance per meter:

$$R_{L,STO,1m} = \frac{\rho \cdot l}{A} \cdot (1 + \alpha \cdot (T_{amb} - T_0)) = \frac{0.01786 \frac{\Omega \cdot \text{mm}^2}{\text{m}} \cdot 1\text{m}}{0.34\text{mm}^2} \cdot \left(1 + 3.93 \cdot 10^{-3} \cdot \frac{1}{\text{K}} \cdot (20 - 20)\text{K}\right) = 525\text{ m}\Omega$$

**Calculation of the voltages applied to the enable inputs:****15 m cable**

$$U_{IN,STO,1} = U_{STO} - 5 \cdot I_{IN} \cdot (2 \cdot R_{L,STO,15m} + 2 \cdot R_{int,STO}) = 30\text{V} - 5 \cdot 6\text{mA} \cdot (2 \cdot 15 \cdot 525\text{m}\Omega + 2 \cdot 83.3\text{m}\Omega) = 29.948\text{ V}$$

**5 m cable**

$$U_{IN,STO,2} = U_{IN,STO,1} - 4 \cdot I_{IN} \cdot (2 \cdot R_{L,STO,5m} + 4 \cdot R_{int,STO}) = 29.948\text{V} - 4 \cdot 6\text{mA} \cdot (2 \cdot 5 \cdot 525\text{m}\Omega + 4 \cdot 83.3\text{m}\Omega) = 29.927\text{ V}$$

**10 m cable**

$$U_{IN,STO,3} = U_{IN,STO,2} - 3 \cdot I_{IN} \cdot (2 \cdot R_{L,STO,10m} + 4 \cdot R_{int,STO}) = 29.927\text{V} - 3 \cdot 6\text{mA} \cdot (2 \cdot 10 \cdot 525\text{m}\Omega + 4 \cdot 83.3\text{m}\Omega) = 29.902\text{ V}$$

**10 m cable**

$$U_{IN,STO,4} = U_{IN,STO,3} - 2 \cdot I_{IN} \cdot (2 \cdot R_{L,STO,10m} + 4 \cdot R_{int,STO}) = 29.902\text{V} - 2 \cdot 6\text{mA} \cdot (2 \cdot 10 \cdot 525\text{m}\Omega + 4 \cdot 83.3\text{m}\Omega) = 29.885\text{ V}$$

**15 m cable**

$$U_{IN,STO,5} = U_{IN,STO,4} - 1 \cdot I_{IN} \cdot (2 \cdot R_{L,STO,15m} + 4 \cdot R_{int,STO}) = 29.885\text{V} - 1 \cdot 6\text{mA} \cdot (2 \cdot 15 \cdot 525\text{m}\Omega + 4 \cdot 83.3\text{m}\Omega) = 29.874\text{ V}$$

Operation in this configuration is possible from the point of view of the enable signal because  $29.874\text{ V} > 15\text{ V}$ .

## 6 Installation and wiring

### 6.1 ACOPOSremote

#### 6.1.1 Installation

##### 6.1.1.1 General information

##### Quality of the mounting surface

The mounting surface for ACOPOSremote modules must provide sufficient stability for the modules in addition to being non-flammable, level and free of contaminants.

#### Warning!

The information listed in [2.7 "Handling and installation" on page 12](#) must be observed!

#### Caution!

The evenness of the mounting surface is particularly important since ACOPOSremote modules rest on the entire surface. The mounting surface must meet the criterion "evenness of 1 mm over the entire mounting surface". When mounting on uneven mounting surfaces, the heat dissipation from ACOPOSremote modules to the mounting plate may be impaired!

#### Caution!

The temperature of the mounting surface may not exceed 60°C.

#### Mounting the modules

Install the module into the system:

- Required tools: Hex key, size 5
- Create fixing holes in the mounting surface as shown in Section [Fig. 80 "Dimension diagram and installation dimensions" on page 290](#).
- Fix the module to the mounting surface using 4 x M6x80 fixing screws (accessory set 8CXM000.000x-00).

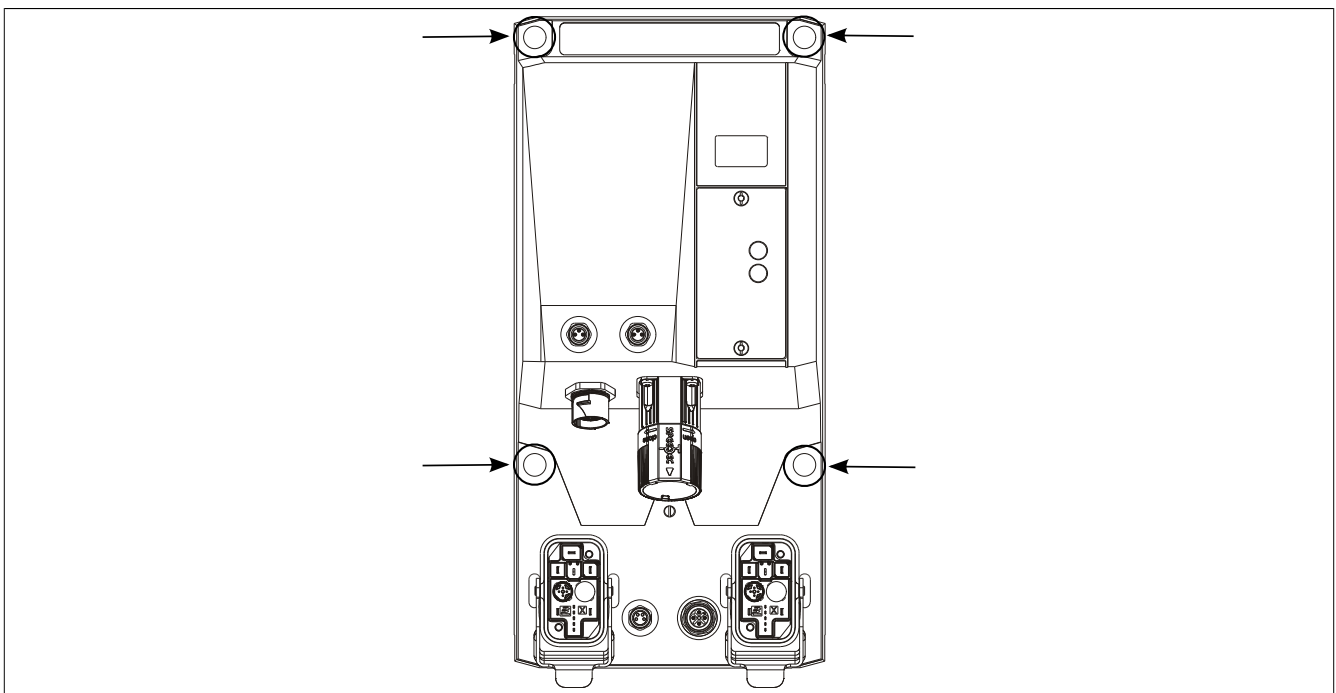

Figure 79: 8CVI inverter modules - Position of mounting screws

### 6.1.1.2 Dimension diagrams and installation dimensions

#### 6.1.1.2.1 8CVI power inverter modules

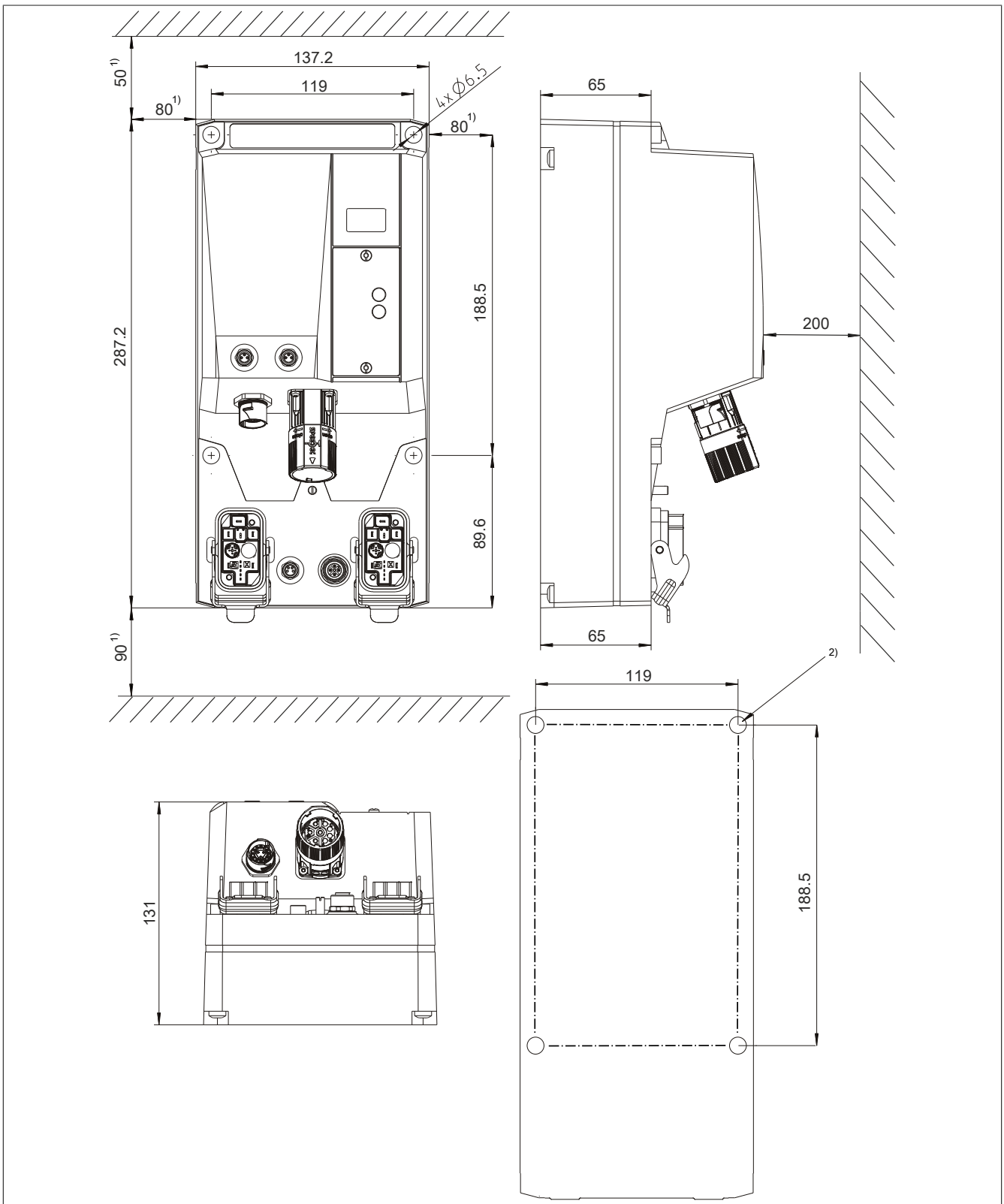

Figure 80: Dimension diagram and installation dimensions

- 1) To ensure adequate air circulation, make sure that the specified clearance is maintained.
- 2) 4x M6, depth min. 20 mm

## 6.2 8CVE connection box

## 6.2.1 Installation

### 6.2.1.1 General information

#### Quality of the mounting surface

The mounting surface for ACOPOSremote modules must provide sufficient stability for the modules in addition to being non-flammable, level and free of contaminants.

#### **Warning!**

The information listed in [2.7 "Handling and installation"](#) on page 12 must be observed!

#### **Caution!**

It is especially important that the mounting surface is level since the entire surface of the ACOPOSremote modules rests against it. The mounting surface must meet the criteria "Smoothness of 1 mm over the entire mounting surface". Mounting on uneven surfaces can lead to reduced heat dissipation from the ACOPOSremote modules to the mounting plate!

#### **Caution!**

The temperature of the mounting surface may not exceed 60°C.

### 6.2.1.2 Dimension diagrams and installation dimensions

#### 6.2.1.2.1 8CVE connection box

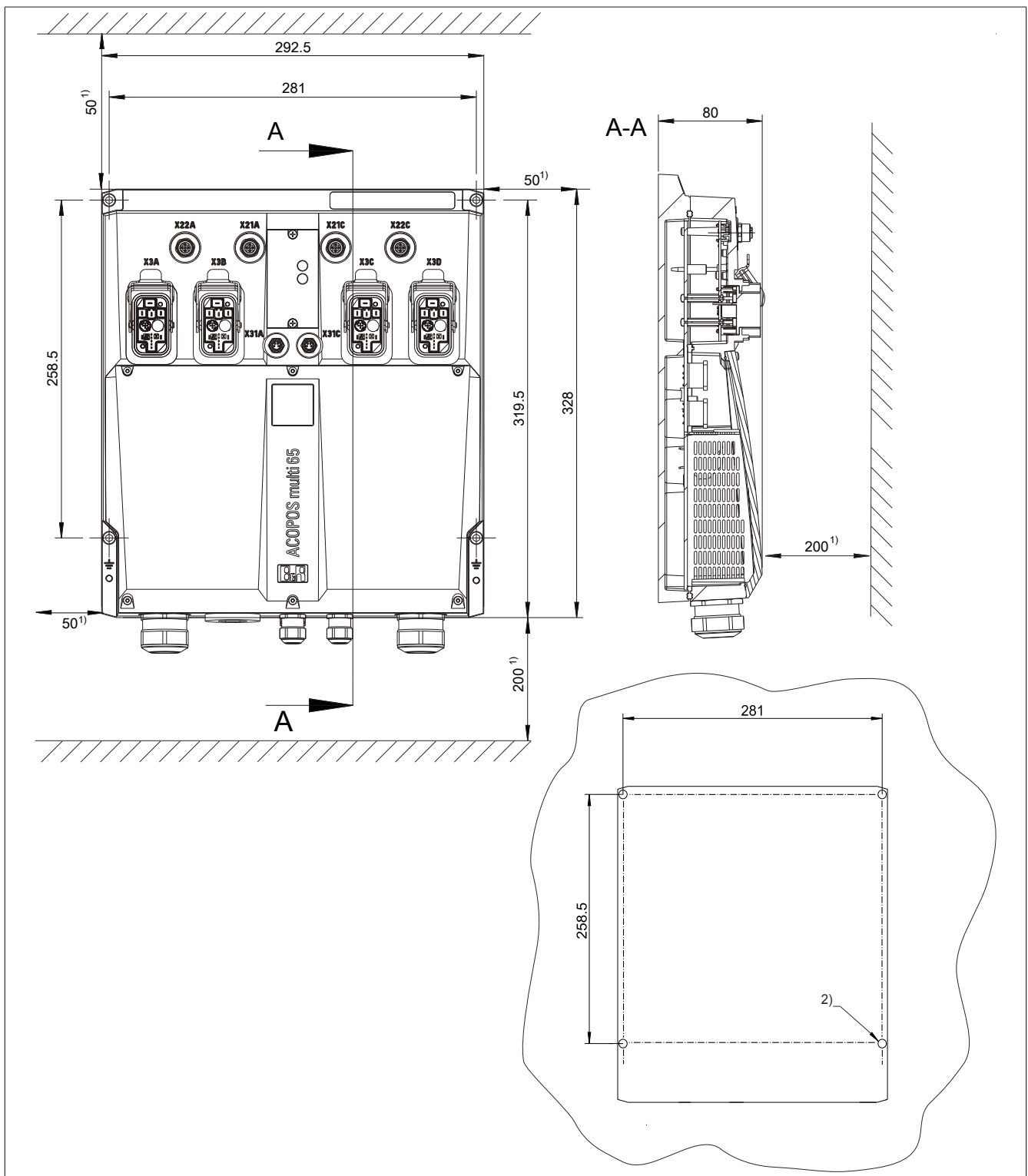

Figure 81: Dimension diagram and installation dimensions

- 1) The specified clearance is necessary to avoid problems when cabling the module.
- 2) 4x M6, depth min. 20 mm

### 6.2.1.3 Configuration of the 8CVE connection box

Before commissioning the module, device fuses must be used in the 8CVE connection box in accordance with the application requirements. The slots for the fuses are located under the front cover of the connection box.

#### Note:

**B&R recommends that the 8CVE connection box be configured before it is installed in the system.**

1. Remove front cover:

- Required tools: Size 10 Torx screwdriver
- Remove the 6 fixing screws indicated (M3x8 Torx screws)
- Remove the front cover from the module

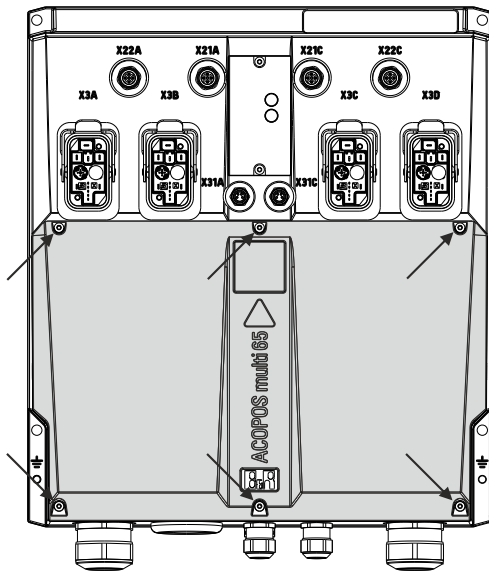

With front cover

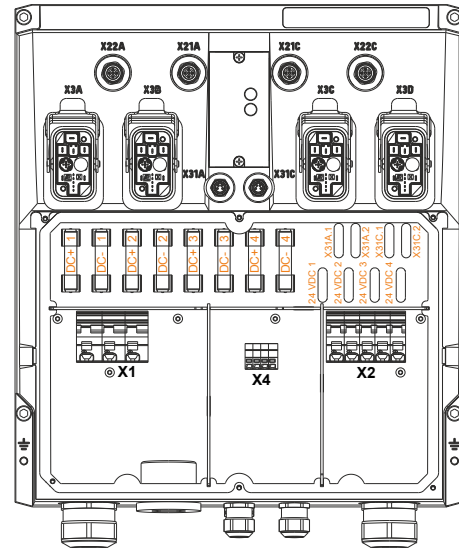

Without front cover

2. Insert fuses for connections X3 (hybrid cables) and X31 (24 VDC routing):

Depending on the connections used, use the relevant fuses as specified in the table.

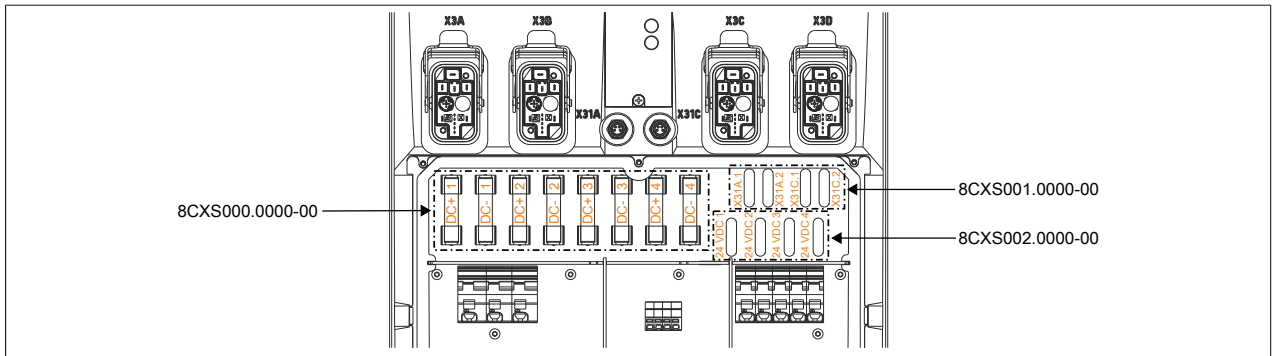

Fuse set	Fuse	Hybrid cable outlets				24 VDC routing	
		X3A	X3B	X3C	X3D	X31A	X31C
8CXS000.0000-00	DC+1	x					
	DC-1	x					
	DC+2		x				
	DC-2		x				
	DC+3			x			
	DC-3			x			
	DC+4				x		
8CXS002.0000-00	24VDC1	x					
	24VDC2		x				
	24VDC3			x			
	24VDC4				x		
8CXS001.0000-00	X31A.1					x	
	X31A.2					x	
	X31C.1						x
	X31C.2						x

3. Fit front cover:

- Required tools: Size 10 Torx screwdriver
- Place the front cover on the module
- Attach the front cover using the 6 fastening screws indicated (M3x8 Torx screws)

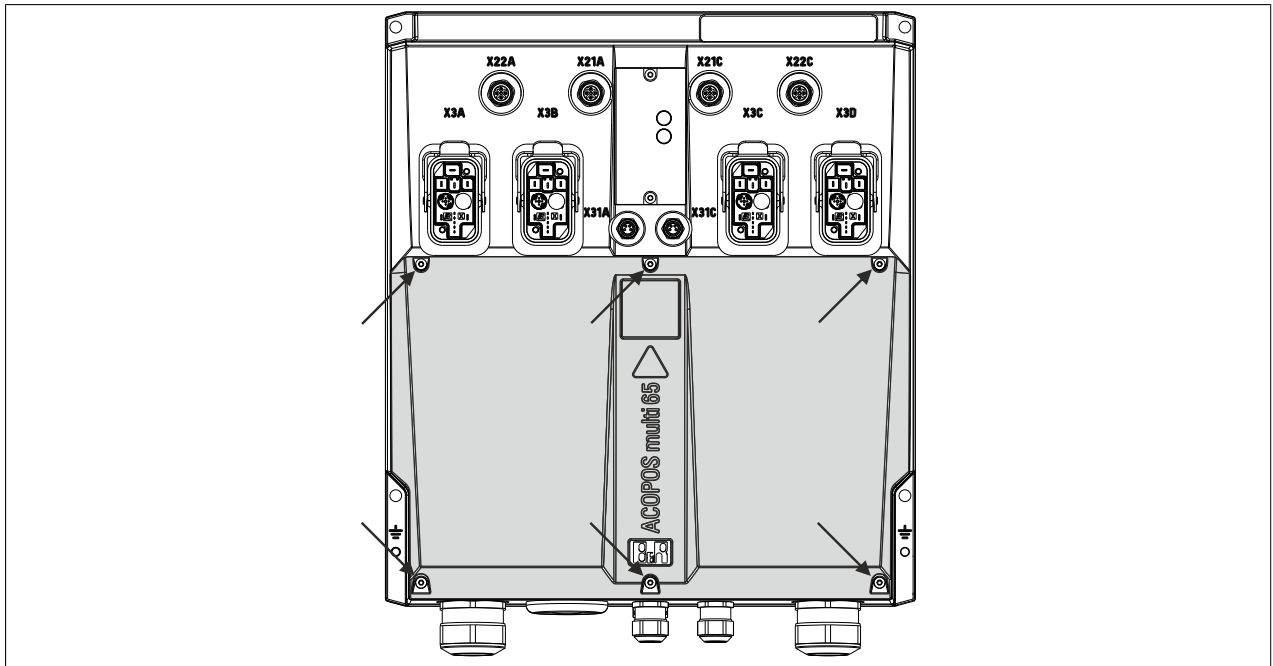

### 6.2.1.3.1 Replacing device fuses

The device fuses for the 8CVE connection box are located under a cover on the front of the module.

## Danger!

**Before performing service work, disconnect the power supply and wait 5 minutes to ensure that the DC bus of the drive system has discharged. Observe regulations!**

1. Remove front cover:

- Required tools: Size 10 Torx screwdriver
- Remove the 6 fixing screws indicated (M3x8 Torx screws)
- Remove the front cover from the module

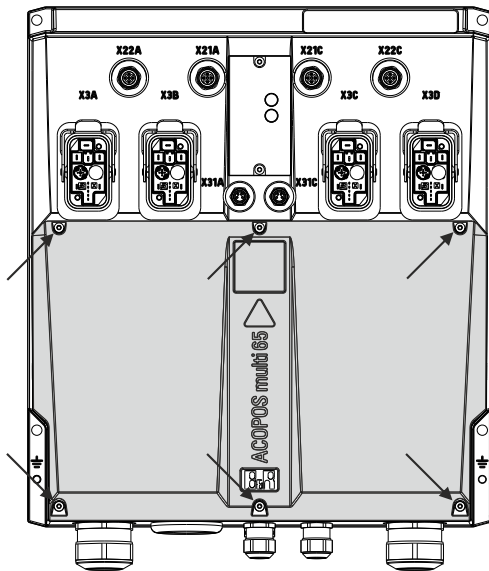

With front cover

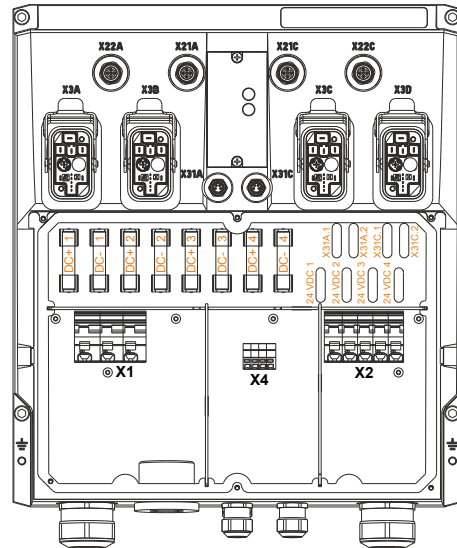

Without front cover

2. Remove fuse(s) for X3 (hybrid cable outlets) and/or X31 (24 VDC forwarding) connectors and replace with new fuse(s):

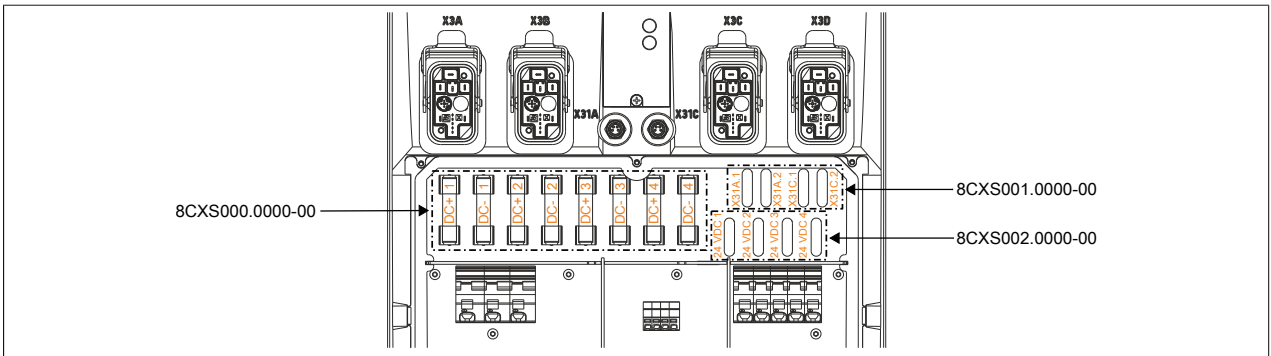

Fuse set	Fuse	Hybrid cable outlets				24 VDC routing	
		X3A	X3B	X3C	X3D	X31A	X31C
8CXS000.0000-00	DC+1	x					
	DC-1	x					
	DC+2		x				
	DC-2		x				
	DC+3			x			
	DC-3			x			
	DC+4				x		
	DC-4				x		
8CXS002.0000-00	24VDC1	x					
	24VDC2		x				
	24VDC3			x			
	24VDC4				x		
8CXS001.0000-00	X31A.1					x	
	X31A.2					x	
	X31C.1						x
	X31C.2						x

3. Fit front cover:

- Required tools: Size 10 Torx screwdriver
- Place the front cover on the module
- Attach the front cover using the 6 fastening screws indicated (M3x8 Torx screws)

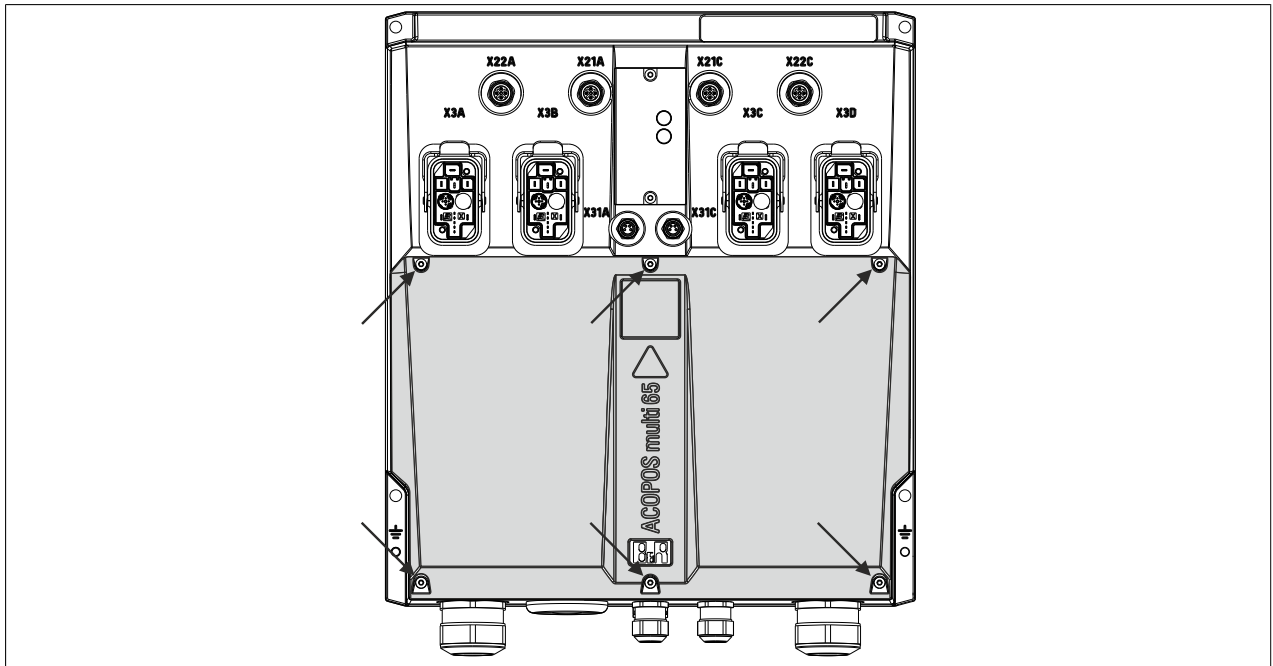

### 6.2.1.4 Install the 8CVE connection box

1. Install the connection box in the system:

- Required tools: Hex key, size 5
- Create fixing holes in the mounting surface as shown in Section Fig. 81 "Dimension diagram and installation dimensions" on page 293.
- Fix the 8CVE module to the mounting surface using 4 x M6x25 fixing screws (accessory set 8CXM001.0000-00).

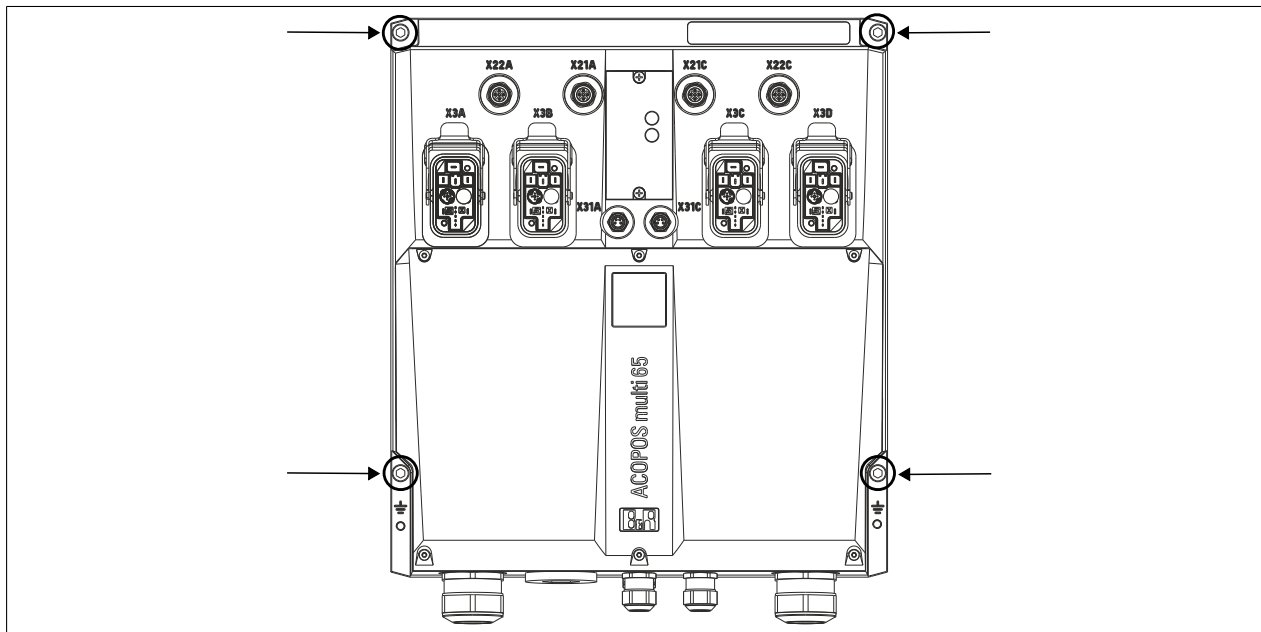

Figure 82: Installing the 8CVE connection box

#### Note:

8CVE modules only comply with IP65 as set out in EN 60529 if all the unallocated connections are covered with blind covers. Suitable caps and covers are available as optional accessories (X67AC0M08, X67AC0M12, 8CXC000.0000-00). The module is rated at IP20 when delivered.

### 6.2.1.5 Cabling for the 8CVE connection box

The connections for the voltage supply as well as the STO inputs are located under the front cover on the 8CVE connection box.

1. Remove front cover:

- Required tools: Size 10 Torx screwdriver
- Remove the 6 fixing screws indicated (M3x8 Torx screws)
- Remove the front cover from the module

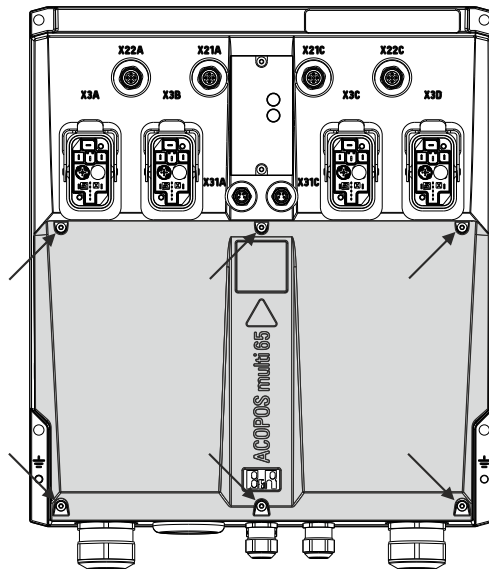

With front cover

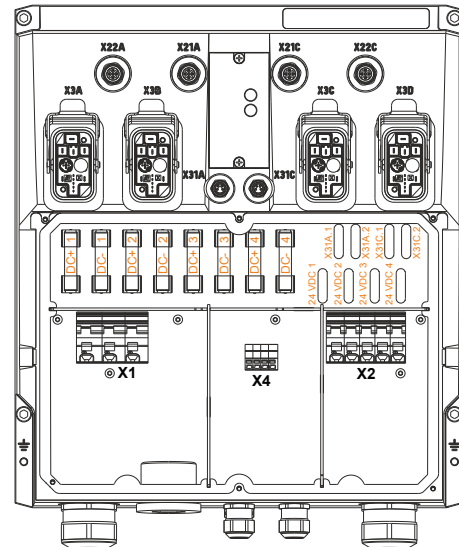

Without front cover

2. Create connections for voltage supply and STO in accordance with the diagram and Section 4.2.2.1.4.1 "Overview" on page 89

#### Note:

The voltage supply for the 8CVE connection box may only be provided via an ACOPOSmulti drive system (expansion module 8BVE).

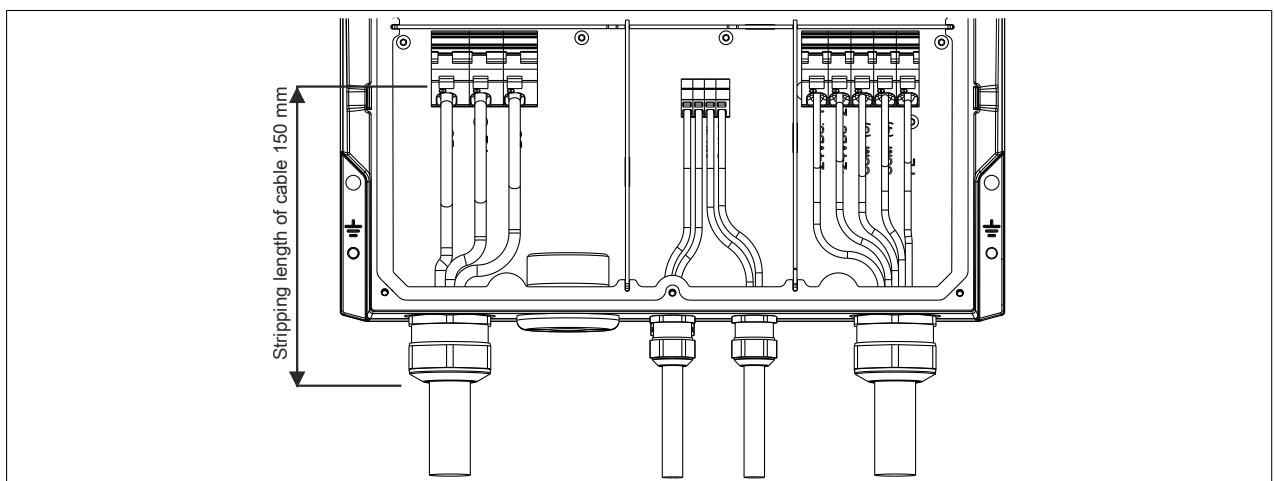

3. Fit front cover:

- Required tools: Size 10 Torx screwdriver
- Place the front cover on the module
- Attach the front cover using the 6 fastening screws indicated (M3x8 Torx screws)

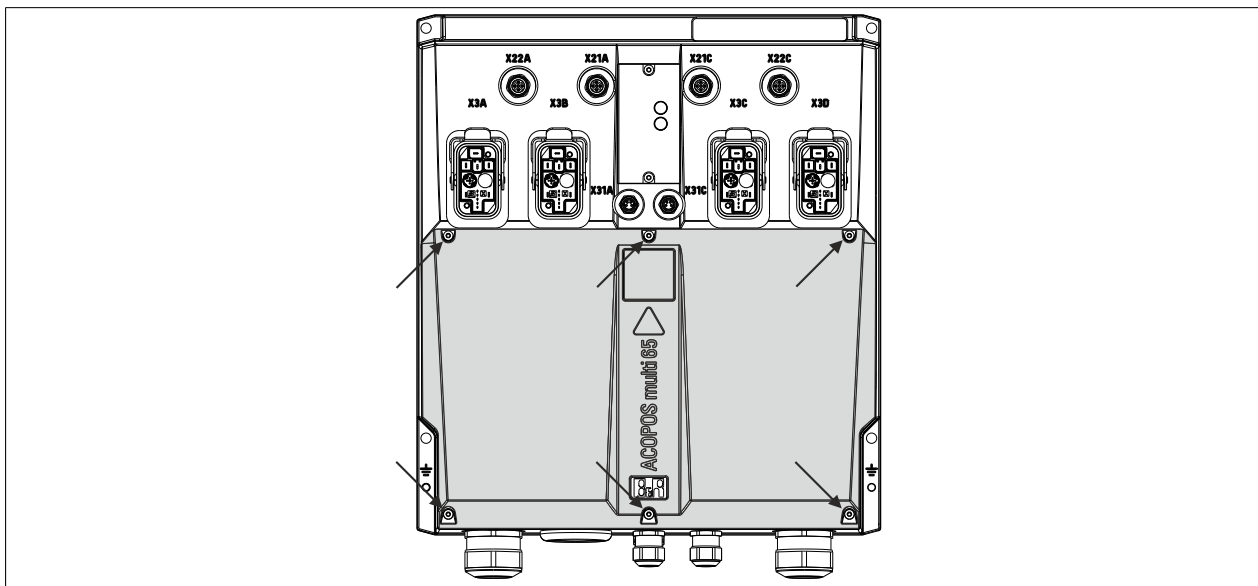

**Note:**

8CVE modules only comply with IP65 as set out in EN 60529 if all the unallocated connections are covered with blind covers. Suitable caps and covers are available as optional accessories (X67AC0M08, X67AC0M12, 8CXC000.0000-00). The module is rated at IP20 when delivered.

## 6.3 ACOPOSmotor / ACOPOSmotor Compact

### 6.3.1 Installation and connection

#### 6.3.1.1 Before installation

Read this user's manual completely before performing any work activities.

In addition, take into account the technical documentation for all other machine components as well as the finished machine.

#### 6.3.1.2 Safety

Work on and wiring of ACOPOSmotor (8DI) and ACOPOSmotor Compact (8D1) modules is only permitted to be carried out when they are in a voltage-free state and only by qualified personnel<sup>2)</sup>. The control cabinet must first be disconnected from the power supply and secured against being switched on again.

Only use appropriate equipment and tools. Protect yourself with safety equipment.

### **Warning!**

**Personal injury and damage to property due to unauthorized modifications!**

**As a result of unauthorized modifications to the product, the performance and limit values can be negatively affected and dangers can arise. Due to this, severe damage to property and injuries cannot be excluded.**

**Unauthorized modifications are therefore prohibited!**

- **Do not carry out any unauthorized modifications or alterations to the product.**
- **If necessary, contact B&R.**

#### 6.3.1.2.1 General sources of danger

##### **Tampering of protection or safety devices**

Protective and/or safety devices protect you and other persons from dangerous voltage, rotating or moving elements and hot surfaces.

### **Danger!**

**Personal injury and damage to property due to tampering of protective equipment!**

**If protective or safety devices are removed or put out of operation, there is no longer any personal protection and serious personal injury and damage to property can occur.**

- **Do not remove any safety devices.**
- **Do not put any safety devices out of operation.**
- **Always use all safety devices also for temporary testing and trial operations!**

##### **Dangerous voltage**

To operate the motors, dangerous voltage must be applied to certain parts.

<sup>2)</sup> see "Qualified personnel" on page 11

## **Danger!**

### **Risk of injury due to electric shock!**

If live parts are touched, there is immediate danger of fatal electric shock.

If connections are connected or disconnected in the incorrect order or when the power is switched on, electric arcs can occur and persons and contacts can be damaged.

Even if the motor is not rotating or is running as a generator driven externally, the control and power connections can still carry voltage!

- Never touch connections when the power is switched on.
- Never disconnect or connect electrical connections to the motor and servo drive when the power is switched on!
- Do not stay in the danger zone during operation and secure it against access by unauthorized persons.
- Always operate the motor with all safety equipment. Do this also for temporary testing and trial operations!
- Keep all covers and control cabinet doors closed during operation and as long as the machine is not disconnected from the mains.
- Before working on motors, gearboxes or servo drives or in the danger zone of your machine, disconnect them completely from the mains and secure them against being switched on again by other persons or automatic systems.
- Note the discharge time of any existing DC bus.
- Only connect measuring instruments when the power is switched off!

### **Danger due to electromagnetic fields**

Electromagnetic fields are generated by the operation of electrical power engineering equipment such as transformers, drives and motors.

## **Danger!**

### **Danger to health due to electromagnetic fields!**

The functionality of a heart pacemaker can be impaired by electromagnetic fields to such an extent that the wearer experiences harm to his or her health, possibly with a fatal outcome.

- Observe relevant national health and safety regulations.
- Persons with pacemakers are not allowed to be in endangered areas.
- Warn staff by providing information, warnings and safety identification.
- Secure the danger zone by means of barriers.
- Ensure that electromagnetic fields are reduced at their source (using shields, for example).

### **Dangerous motion**

By rotating and positioning motions of the motors, machine elements are moved or driven and loads conveyed.

After switching on the machine, movements of the motor shaft must always be expected! For this reason, high-level protective measures must be put in place to ensure that personnel and the machine are protected. This type of protection can be achieved, for example, by using stable mechanical protective equipment such as protective covers, protective fences, protective gates or photoelectric sensors.

In the immediate vicinity of the machine, provide sufficient and easily accessible emergency switching-off devices to stop the machine as quickly as possible in the event of an accident.

## Danger!

**Danger of injury due to rotating or moving elements and loads!**

By rotating or moving elements, body parts can be drawn in or severed or subjected to impacts.

- Do not stay in the danger zone during operation and secure it against access by unauthorized persons.
- Before working on the machine, secure it against unwanted movements. If a holding brake is available, it must be checked for functionality after machine actuators have been attached and after maintenance and repair work has been carried out!
- Keep all covers and control cabinet doors closed during operation and as long as the machine is not disconnected from the mains.
- Always operate the motor with all safety equipment. Do this even during short testing and trial operations!
- Motors can be started automatically via remote control! If appropriate, a corresponding warning symbol must be applied, and protective measures must be implemented to prevent entry into the high-risk area!

## Danger!

**Danger of injury due to loads!**

Suspended loads can result in personal injury or death if they fall down. Heavy loads can tilt and trap people or severely injure them.

Failure to comply with instructions, guidelines and regulations or use of unsuitable or damaged tools and devices can result in serious injury and/or damage to property.

- Motors should only be lifted without any additional load from other products (e.g. connection elements).
- Only use permitted lifting, transport and aids with sufficient lifting capacity.
- Never stand in the danger zone or under suspended loads.
- Secure the product against dropping and tilting.
- Wear safety shoes, protective clothing and a safety helmet.
- Comply with the national and local regulations.

## Warning!

**Danger of injury due to incorrect control or a defect!**

Improper control of motors or a defect can result in injuries and unintended and hazardous movements of motors.

Such incorrect behavior can be triggered by:

- Incorrect installation or faults when handling components
- Improper or incomplete wiring
- Defective devices (servo drive, motor, position encoder, cables, brake)
- Incorrect control (e.g. caused by software error)

### Risk due to hot surfaces

Due to the power dissipation from the motor and friction in the gearbox, these components as well as their environment can reach a temperature of more than 100°C.

The resulting heat is released to the environment via the housing and the flange.

## Warning!

### Risk of burns due to hot surfaces!

Touching hot surfaces (e.g. motor and gearbox housings, as well as connected components), can result in very severe burns due to the very high temperature of these parts.

- Do not stay in the danger zone during operation and secure it against access by unauthorized persons.
- Never touch the motor or gearbox housing as well as adjacent surfaces during nominal load operation.
- Be aware of hot surfaces also during standstill.
- Allow the motor and gearbox to cool down sufficiently before working on them; there remains the risk of burns for a long period of time after they are switched off.
- Always operate the motor or gearbox with all safety devices. Do this also for temporary testing and trial operations!

### 6.3.1.2.2 Noise emissions

Take into account the health of personnel in proximity to the machine.

## Warning!

### Hearing damage due to noise levels.

During operation, the motor can exceed the permissible workplace noise level and also cause hearing damage.

- Implement suitable noise reduction measures (e.g. housings, covers or other sound-insulating measures).
- Take into account applicable industrial safety regulations.

### 6.3.1.3 Shaft end and bearing

The motor shaft is supported on both sides with grease-lubricated grooved ball bearings. Protect the motor from damage due to excessive radial and axial forces!

Under all circumstances, avoid the following loads on the front shaft end or the rear motor housing cover:

- Excessive pressure
- Impacts
- Hammer blows

## Warning!

### Damage due to excessive axial forces!

The motor bearings can be damaged or the service life reduced by excessive axial forces (e.g. by impacting or pressing) on the shaft. Damage to the encoder or any installed options (holding brake, gearbox) is also possible.

- Do not hit the motor or output shaft with a hammer. The impact of a hammer certainly exceeds the permissible values.
- In addition, avoid impact and excessive pressure on the motor and output shaft.

### Overdetermined bearing

Avoid an overdetermined bearing when attaching drive elements onto the output shaft!. The necessarily occurring tolerances cause additional forces on the output shaft bearing. This can damage or significantly reduce the service life of the bearings!

### Lifting and transporting

The weight of attachment elements (toothed gears, pulleys, couplings, etc.) can have a harmful effect on the bearing during lifting and transportation from the motor. Take into account these radial and axial loads during these operations!

**Installing and removing attachment elements**

Always install and remove the attachment elements (toothed gears, pulleys, couplings, etc.) at the shaft end without any axial load on the motor bearings and all other parts installed in the motor. For this, use suitable clamping sets, pressure sleeves, other clamping elements, retractors, etc. The centering hole on the face side of the shaft end can be used for this work.

Pay attention to balanced connection elements or corresponding assembly.

Secure the attachments against unintended loosening after installation and before operation.

### 6.3.1.4 Installing in the system

Before working on motors, gearboxes or servo drives or in the danger zone of your machine, disconnect them completely from the mains and secure them against being switched on again by other persons or automatic systems.

#### Inspection

Before installation, inspect the components to determine whether they are suitable and undamaged.

### Warning!

**Personal injury and damage to property due to damaged or unsuitable machine components!**

**Operating a machine with damaged or unsuitable components is a safety risk and can result in failures. Severe damage to property and injuries cannot be excluded.**

- Never operate a machine with a damaged motor or gearbox or any other damaged component.
- Never install a damaged component in a machine.
- Do not use motors or gearboxes that have already been overloaded during operation.
- Before installation, ensure that the motor or gearbox is suitable for the machine.
- It is better not to carry out short-term test and trial operations with damaged or inappropriate machine components.
- Label damaged or non-operational components in a readily visible location and clearly.

#### Cleaning

Clean anti-corrosive agents and dirt off the output shaft and flange of the motor as well as the opposite side of the shaft and flange on the machine.

### Caution!

**Damage to property caused by improper cleaning.**

**Contact with cleaning agents can damage oil seals, sealing lips and gaskets.**

- Only use suitable and material-friendly cleaning agents.
- Ensure that oil seals, sealing lips and gaskets do not come into contact with cleaning agents.

#### Installation with the mounting flange

Attach the motor with the motor flange, which also serves as a cooling surface, directly onto the machine.

For this, the motor must be screwed to the machine via the flange.

Apply tightening torque in accordance with the standard when tightening the screws and use a screw locking mechanism.

#### 6.3.1.4.1 Fasteners and tightening torques

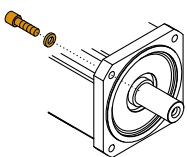

Use socket head cap screws (ISO 4762 - Property class min. 8.8) and flat washers.

Tighten the screws evenly in diagonally opposite sequence and with the correct tightening torque to avoid distorting the flange and excessively straining screws.

The specified values for screws are calculated values and based on the following requirements:

- Coefficient of friction  $\mu = 0.14$
- Screwing into steel

If the motor is screwed onto other materials or if there are different surface roughnesses, the user must determine the correct tightening torque.

#### ACOPOSmotor

	Screw	Flat washer [mm]	Tightening torque [Nm]
8Dlx3	M6	6.4 x 11	10
8Dlx4	M8	8.4 x 14	23
8Dlx5	M10	10.5 x 18	43

**ACOPOSmotor Compact**

	Screw	Flat washer [mm]	Tightening torque [Nm]
8D1x2	M5	5.3 x 9	6

**6.3.1.5 Connecting and disconnecting the motor**

Observe the following safety guidelines and instructions when connecting and disconnecting the motor:

The module must be connected to ground potential.

**Danger!**

**Personal injury and damage to property due to missing ground potential!**

If there is no proper ground potential on the module, fault currents can result in serious personal injury and damage to property.

- Connect the ACOPOSmotor module (8DI) properly to ground potential (PE rail) via the ground connection on the module (also for temporary testing and trial operations!).
- Connect the ACOPOSmotor Compact module (8D1) properly to ground potential (PE rail) via the module motor flange (also for temporary testing and trial operations!).

**Danger!**

**Risk of injury due to electric shock!**

If live parts are touched, there is immediate danger of fatal electric shock.

If connections are connected or disconnected in the incorrect order or when the power is switched on, electric arcs can occur and persons and contacts can be damaged.

Even if the motor is not rotating or is running as a generator driven externally, the control and power connections can still carry voltage!

- Never touch connections when the power is switched on.
- Never disconnect or connect electrical connections to the motor and servo drive when the power is switched on!
- Do not stay in the danger zone during operation and secure it against access by unauthorized persons.
- Always operate the motor with all safety equipment. Do this also for temporary testing and trial operations!
- Keep all covers and control cabinet doors closed during operation and as long as the machine is not disconnected from the mains.
- Before working on motors, gearboxes or servo drives or in the danger zone of your machine, disconnect them completely from the mains and secure them against being switched on again by other persons or automatic systems.
- Note the discharge time of any existing DC bus.
- Only connect measuring instruments when the power is switched off!

**Warning!**

**Risk of burns due to hot surfaces!**

Touching hot surfaces (e.g. motor and gearbox housings, as well as connected components), can result in very severe burns due to the very high temperature of these parts.

- Do not stay in the danger zone during operation and secure it against access by unauthorized persons.
- Never touch the motor or gearbox housing as well as adjacent surfaces during nominal load operation.
- Be aware of hot surfaces also during standstill.
- Allow the motor and gearbox to cool down sufficiently before working on them; there remains the risk of burns for a long period of time after they are switched off.
- Always operate the motor or gearbox with all safety devices. Do this also for temporary testing and trial operations!

### 6.3.1.6 Cable clamp and bend radius

To ensure that cables and connectors are not exposed to harmful loads, the cable clamp (**A**) and minimum bend radius (**R**) must be observed during installation.

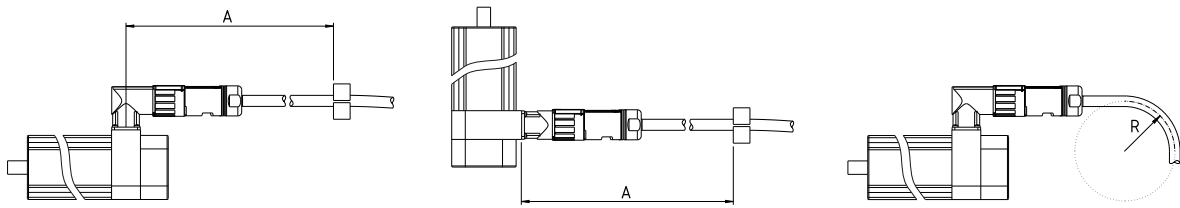

#### Cable clamp (**A**)

- A = Max. 300 mm along longitudinal axis of connector
- The connection must be free of force and torque.
- Movement relative to the connector is not permitted!
- Tensile stress on cables and connectors is not permitted!

#### Bend radius (**R**)

- The minimum radius values can be taken from the current technical data sheet for the cable

# 7 Safety technology

## 7.1 ACOPOSremote / 8CVE connection box / ACOPOSmotor

### 7.1.1 Standard safety technology ("hardwired safety technology")

#### Danger!

Especially in the area of safety technology, always consult the most current version of this document on the B&R website for valid specifications ([www.br-automation.com](http://www.br-automation.com))! The specifications in this version of the document are not necessarily current. The user must verify the correctness of specifications before implementing safety functions!

#### 7.1.1.1 General information

Safe pulse disabling is integrated in 8CVI and 8DI modules for safe stopping and to prevent unexpected startup. This is designed to satisfy the following safety classifications depending on the external circuit: <sup>10)</sup>

Criteria	Characteristic values	
	8CVI	8DI
Maximum safety category per EN ISO 13849	CAT 4	CAT 4
Maximum Performance Level in accordance with EN ISO 13849	PL e	PLe
Maximum Safety Integrity Level in accordance with IEC 62061	SIL 3	SIL 3
Maximum Safety Integrity Level in accordance with IEC 61508	SIL 3	SIL 3
PFH (probability of dangerous failure per hour)	$< 2 * 10^{-10}$	$< 5 * 10^{-10}$
PFH (probability of dangerous failure on demand) dependent on the proof test interval (PTI)		
With a PTI of 10 years	$< 1 * 10^{-5}$	$< 4 * 10^{-5}$
With a PTI of 20 years	$< 2 * 10^{-5}$	$< 7 * 10^{-5}$
PTI (proof test interval)	Max. 20 years	Max. 20 years
DC (diagnostic coverage)	99%	99%
MTTFd (mean time to dangerous failure)	2500 years	2500 years

Table 185: Safety classifications, criteria and characteristics for safe pulse disabling

1) Corresponds to the mission time of the module

The following table provides an overview of the individual safety functions that can be implemented:

Name according to standard		Short description
<b>EN 61800-5-2</b>	<b>EN 60204-1</b>	
STO (Safe Torque Off)	Stop category 0	Cuts off the power supply
SS1 (Safe Stop 1)	Stop category 1	Initiates active braking and activates function STO after a defined amount of time has passed
SS2 (Safe Stop 2)	Stop category 2	Initiates active braking and activates function SOS after a defined amount of time has passed
SLS (Safely Limited Speed)	---	Protection against exceeding a defined speed limit
SOS (Safe Operating Stop)	---	Protection against impermissible position deviation

Table 186: Overview of safety functions according to standards

Safe pulse disabling interrupts the supply to the motor by preventing the pulses to the IGBTs over two channels. In this way, a rotating field can no longer be created in synchronous and induction motors controlled by ACOPOSmicro inverters or in the 8DI modules.

Integrated safe pulse disabling therefore meets the requirements for preventing unexpected startup in accordance with EN 1037 as well as the requirements concerning Category 0 and 1 stop functions in accordance with EN 60204-1. Both stop functions require the power supply to the machine actuators to be switched off (immediately for Category 0 and after reaching standstill for Category 1). The requirements concerning the STO, SS1, SS2, SLS and SOS safety functions are also met in accordance with EN 61800-5-2.

The terminology of EN 61800-5-2 (STO, SS1, SS2, SLS, SOS) will be used in the following.

<sup>10)</sup> For detailed information about the listed standards and safety functions, see section [Standards and certifications](#).

### 7.1.1.2 Principle - Implementing the safety function

Safe pulse disabling is achieved by removing the power supply to the IGBT drivers in the 8CVI modules or 8DI modules. Two integrated 24 VDC DC-to-DC converters are supplied via terminals X3A / Enable1 and X3A / COM (5) as well as X3A / Enable 2 and X3A / COM (2). The two DC-to-DC converters generate the supply voltage for the IGBT drivers from this voltage.

#### 8CVI

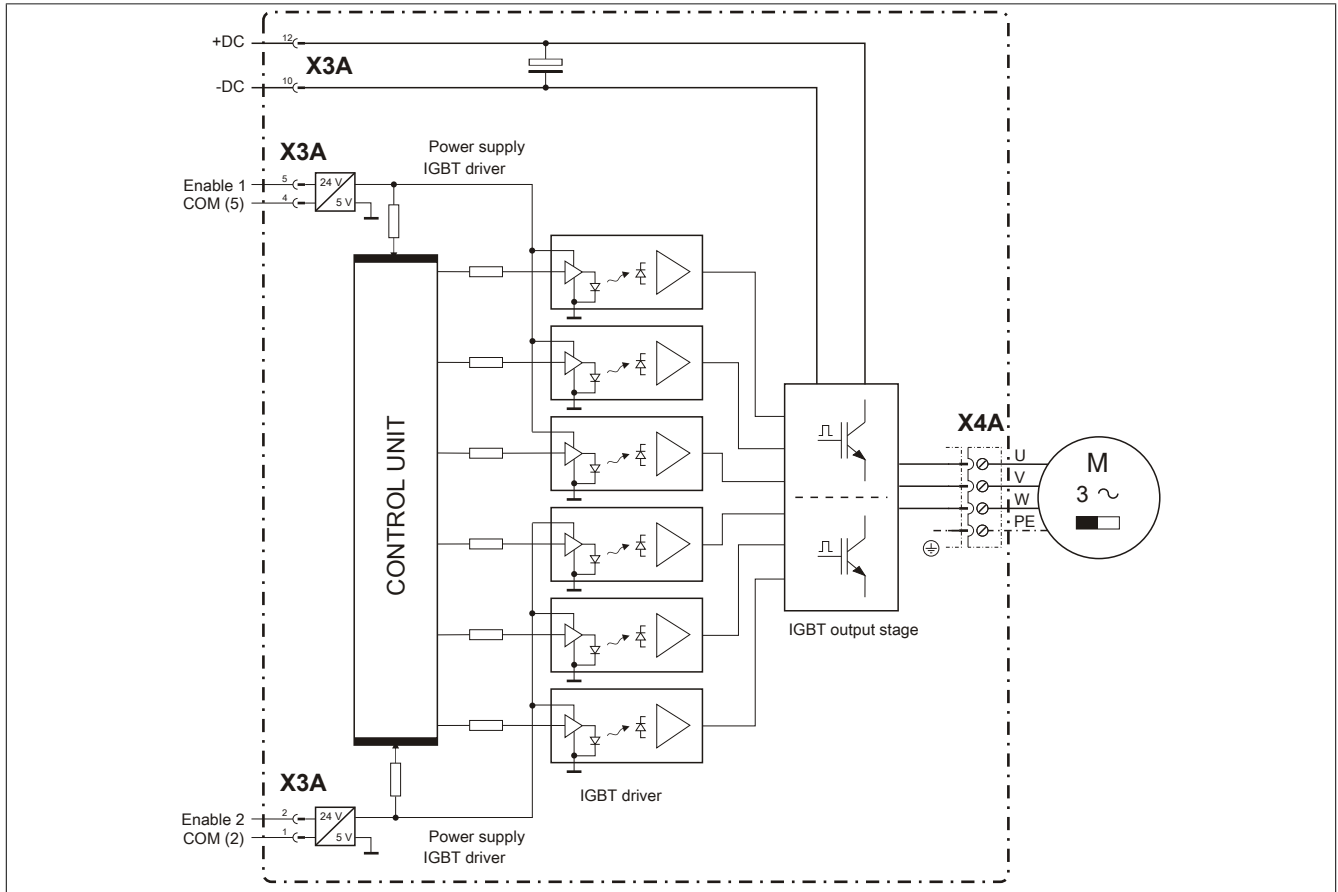

Figure 83: 8CVI - Block diagram for safe pulse disabling

## 8DI

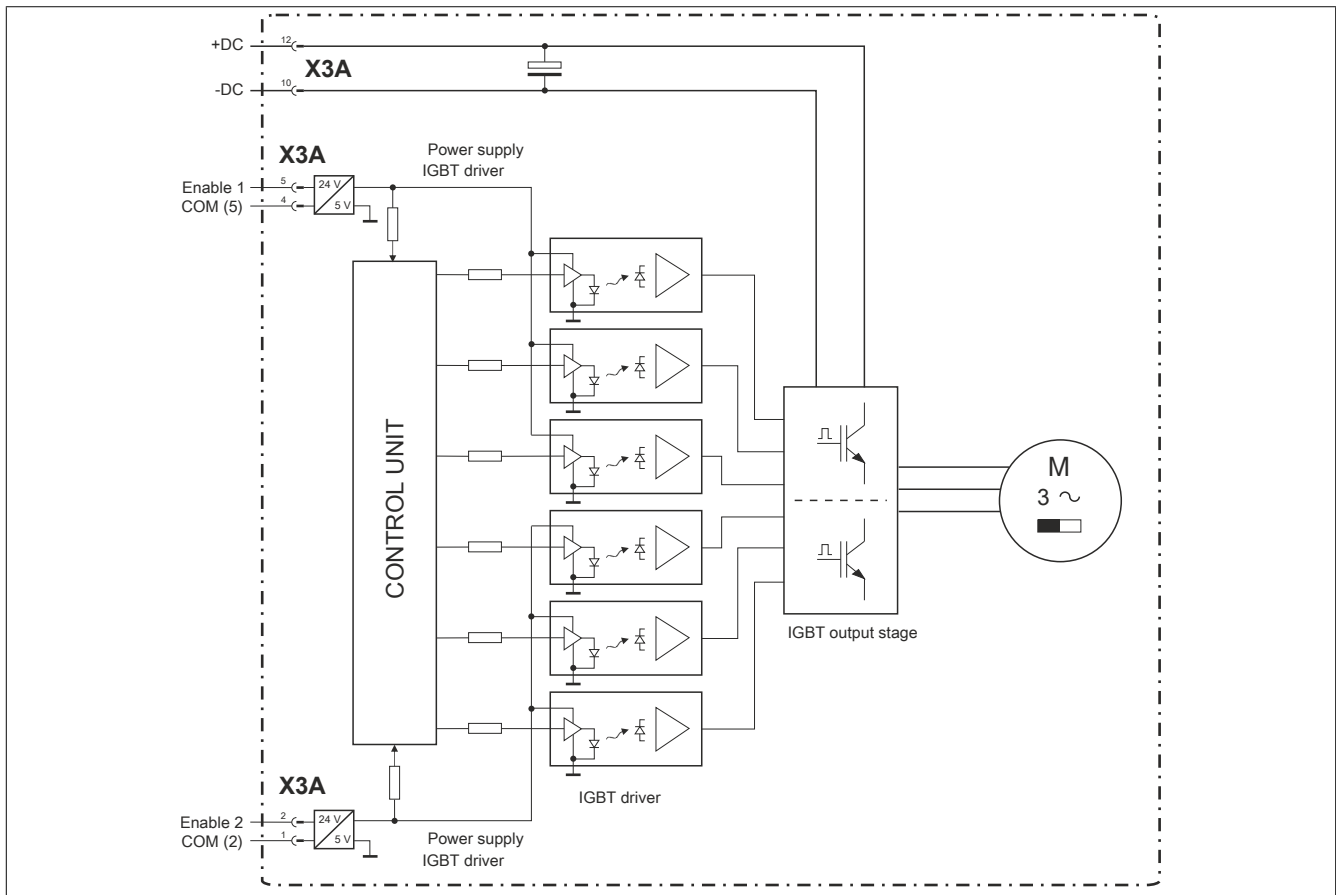

Figure 84: 8DI - Block diagram for safe pulse disabling

If the 24 VDC voltage supply for one of the DC-to-DC converters is interrupted, the corresponding IGBT drivers are also no longer supplied. It is then no longer possible to transfer the modulation pattern needed to generate the rotating field on the IGBT output stage. This cuts off the supply of power to the motor.

#### 7.1.1.2.1 Additional functions

The control unit performs a query to check if the output voltage of the two DC-to-DC converters is present. If voltage is not present on the output of one of the two DC-to-DC converters, then the control unit suppresses the generation of the modulation pattern.

### Danger!

After activating safe pulse disabling using connections X3A / Enable1 and X3A / COM (5) or X3A / Enable 2 and X3A / COM (2), the motor is de-energized and therefore torque-free. If the motor was moving before activation of safe pulse disabling, it is only stopped by a safe operational brake (available under certain conditions) or from the friction of the complete system. The motor is therefore not able to hold hanging loads. Safe holding brakes must be used for this purpose.

### Danger!

The switch-off time for the enable inputs must be taken into consideration since it has a substantial effect on the response time of the safety functions and therefore the remaining distances and times to be considered. In order to calculate the total safety response time, the user must validate the lag time throughout the complete system.

The switch-off times for the enable inputs can be found in the technical data for the respective 8CVI or 8DI module.

### Danger!

Activating safe pulse disabling via the connections X3A / Enable1 and X3A / COM (5) or X3A / Enable 2 and X3A / COM (2) is not sufficient for achieving a de-energized drive and therefore does not provide sufficient protection against electrical shock!

**Danger!**

Depending on the application, it is possible for the drive to restart after safe pulse disabling is deactivated.

**Danger!**

The brake controller integrated in 8CVI and 8DI modules as well as the holding brake integrated in B&R standard motors satisfy the requirements up to Category B in accordance with EN ISO 13849-1.

Additional measures are necessary to achieve higher safety categories.

**Danger!**

The C standards relevant to applications must be observed!

**Danger!**

Note that an error can cause a brief forward movement. The maximum turning angle of the motor shaft  $\varphi$  during this forward movement depends on the motor being used.

For permanently excited synchronous motors,  $\varphi = 360^\circ/2p$  (for B&R standard motors,  $p=3$  so the angle is  $60^\circ$ ). For three-phase induction motors, there is a relatively small angle of rotation (between  $5^\circ$  and  $15^\circ$ ).

**7.1.1.3 Wiring the enable inputs to the required Safety Category / SIL / PL**

Using the example of the STO safety function, different circuit variations for the enable inputs of 8CVI or 8DI modules are given here with regard to the required Safety Category / SIL / PL.

**Danger!**

Any faults (e.g. cross faults) that are not detected can lead to the loss of safety functionality.

Appropriate measures must be taken to justify the exclusion of errors. For instance, faults caused by a short circuit between any two wires can be excluded per EN ISO 13849-2, appendix D.5, if one of the following conditions is met:

- The wires are permanently installed and protected against external damage (e.g. using a cable duct or armored conduit).
- The wires are installed in different plastic-sheathed cables or within an area for electrical equipment<sup>11)</sup>.
- The wires are each individually protected by a ground connection.

For more fault exclusions, see EN ISO 13849-2, appendix D.5.

**Danger!**

To achieve Safety Category 4 / SIL 3 / PL e, it must be ensured that a buildup of errors does not lead to a loss of safety functionality. Monitoring can be aborted after the third error if the likelihood that more errors will occur can be considered low.

To achieve Safety Category 3 / SIL 2 / PL d, it must be ensured that a single error does not lead to a loss of safety functionality.

**7.1.1.3.1 STO, Category 4 / SIL 3 / PL e (Variant A)**

An enable input on the 8CVI or 8DI module is supplied with +24 V via a switching contact of a safe E-stop switching device. The COM of the second enable input on the 8CVI or 8DI module is supplied with 0 V via another switching contact of a safe E-stop switching device. Activating the S1 E-stop switch opens both switching contacts on the E-stop device, cutting off the enable input and the COM of the second enable input.

<sup>11)</sup> Prerequisite: Both the wires and the area for electrical equipment must meet the respective requirements (see IEC 60204-1).

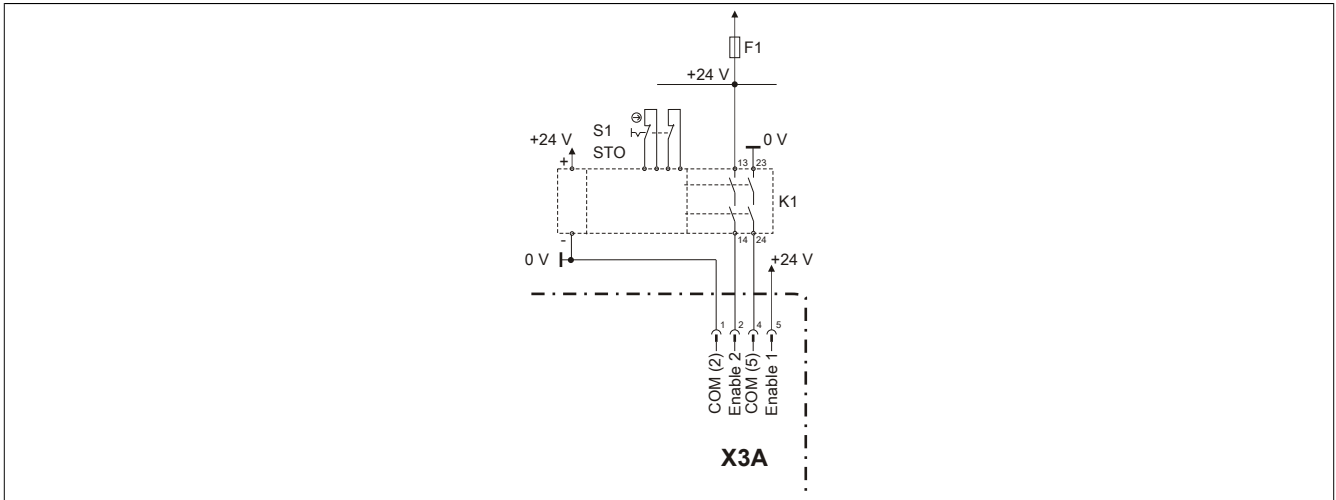

Figure 85: STO, Category 4 / SIL 3 / PL e (Variant A)

This circuit covers a majority of the wiring and isolation errors in the area of supply lines to the E-stop switching device and to the enable inputs.

The following errors can occur in the external circuit: <sup>12)</sup>

Error	Error description	Effects	Safety functionality in accordance with Category 4 / SIL 3 / PL e maintained?
1	Interruption of the supply line to connection 13	Power to the motor is cut off	Yes
2	Interruption of the supply line to connection 23	Power to the motor is cut off	Yes
3	Short circuit between connection 13 and 23	F1 fuse triggered immediately	Yes
4	Short circuit between connection 13 and 0 V	F1 fuse triggered immediately	Yes
5	Short circuit between connection 23 and +24 V	F1 fuse triggered immediately	Yes
6	Short circuit between connection 13 and 24	F1 fuse triggered by requesting safety function	Yes
7	Short circuit between connection 23 and 14	F1 fuse triggered by requesting safety function	Yes
8	<b>Short circuit between connection 13 and 14</b>	<b>Unknown error</b>	<b>No, safety function reverts to Category 3 / SIL 2 / PL d</b>
9	<b>Short circuit between connection 23 and 24</b>	<b>Unknown error</b>	<b>No, safety function reverts to Category 3 / SIL 2 / PL d</b>
10	Interruption of the supply line to connection 14	Power to the motor is cut off	Yes
11	Interruption of the supply line to connection 24	Power to the motor is cut off	Yes
12	Short circuit between connection 14 and 0 V	F1 fuse triggered by requesting safety function	Yes
13	Short circuit between connection 24 and +24 V	F1 fuse triggered by requesting safety function	Yes
14	<b>Short circuit between connection 14 and +24 V</b>	<b>Unknown error</b>	<b>No, safety function reverts to Category 3 / SIL 2 / PL d</b>
15	<b>Short circuit between connection 24 and +0 V</b>	<b>Unknown error</b>	<b>No, safety function reverts to Category 3 / SIL 2 / PL d</b>
16	Short circuit between connection 14 and 24	F1 fuse triggered by requesting safety function	Yes

Table 187: List of possible errors

<sup>12)</sup> The connection numbers refer to "STO, Category 4 / SIL 3 / PL e (Variant A)".

## Danger!

The S1 switch shown requires the use of a two-pin Category 4 / SIL 3 / PL e switching device with a positively driven N.C. contact in accordance with EN 60947-5-1. A two-pin Category 4 / SIL 3 / PL e switching device must be used for the K1 relay shown.

The instructions in the switching device's user documentation must be observed!

It must be possible to exclude the following errors according to "List of possible errors" by taking sufficient measures (wiring protected against short circuit):

- Error 8
- Error 9
- Error 14
- Error 15

### 7.1.1.3.2 STO, Category 4 / SIL 3 / PL e (Variant B)

The two enable inputs on the 8CVI or 8DI module are supplied via a safe digital output (Out1+, Out1-). If the safety function is requested, then the safe digital output disconnects the two enable inputs.

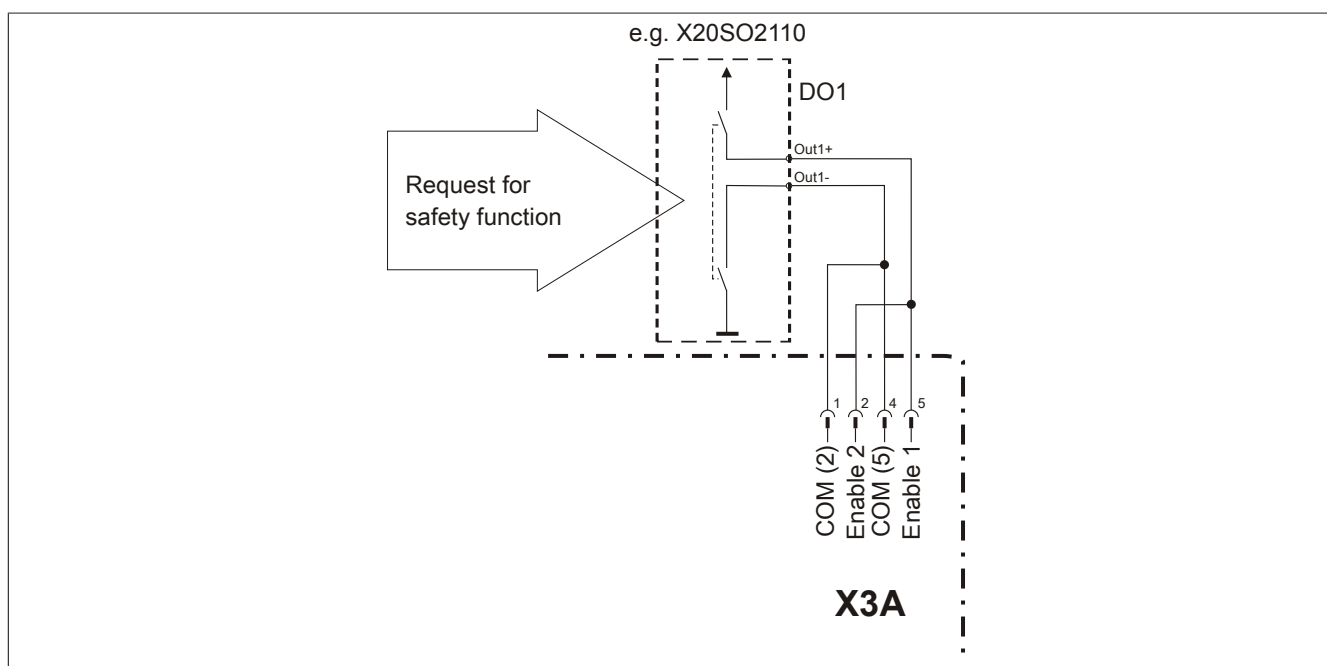

Figure 86: STO, Category 4 / SIL 3 / PL e (Variant B)

Errors in the external wiring do not have to be monitored because they are detected by the safe digital output.

## Danger!

A safe digital Category 4 / SIL 3 / PL e output module must be used for the DO1 safe digital output shown.

The guidelines listed in the safe digital output module's user documentation must be observed!

### 7.1.1.3.3 STO, Category 3 / SIL 2 / PL d

When an E-stop button is pressed, one or both enable inputs on the 8CVI or 8DI module is cut off from the +24 V supply by a switch, thereby cutting off the motor's power supply.

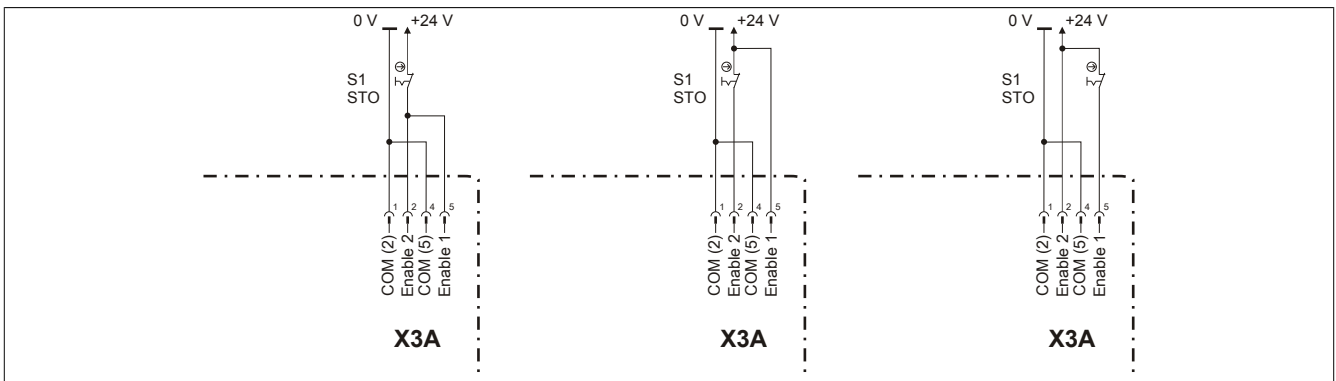

Figure 87: STO, Category 3 / SIL 2 / PL d

#### **Danger!**

If only one of the two enable inputs is disconnected from the +24 V supply using a switch, suitable wiring measures must be taken to rule out a short circuit between the X3A / Enable1 and X3A / Enable2 connections in order to guarantee compliance with the safety category!

#### **Danger!**

A 1-pole category 3 / SIL 2 / PL d switching device with a positively driven normally closed contact must be used for the shown S1 switch per EN 60947-5-1.

The information in the user documentation for the switching device must be observed!

### 7.1.1.4 Wiring the enable inputs to the required Safety Category / SIL / PL and functionality (STO, SS1, SS2, SLS, SOS)

The following illustrates example wiring suggestions for the external wiring of the enable inputs on 8CVI or 8DI modules. They vary in their safety classification in accordance with EN 60204-1, ISO 13849 and EN 61800-5-2 as well as with regard to the safety function (STO, SS1, SS2, SLS, SOS).

#### Information:

The following wiring suggestions do not include a line contactor because it is not needed to comply with the required Safety Category / SIL / PL.

#### 7.1.1.4.1 STO, SLS, SOS - Safety Category 4 / SIL 3 / PL e

##### 8CVI

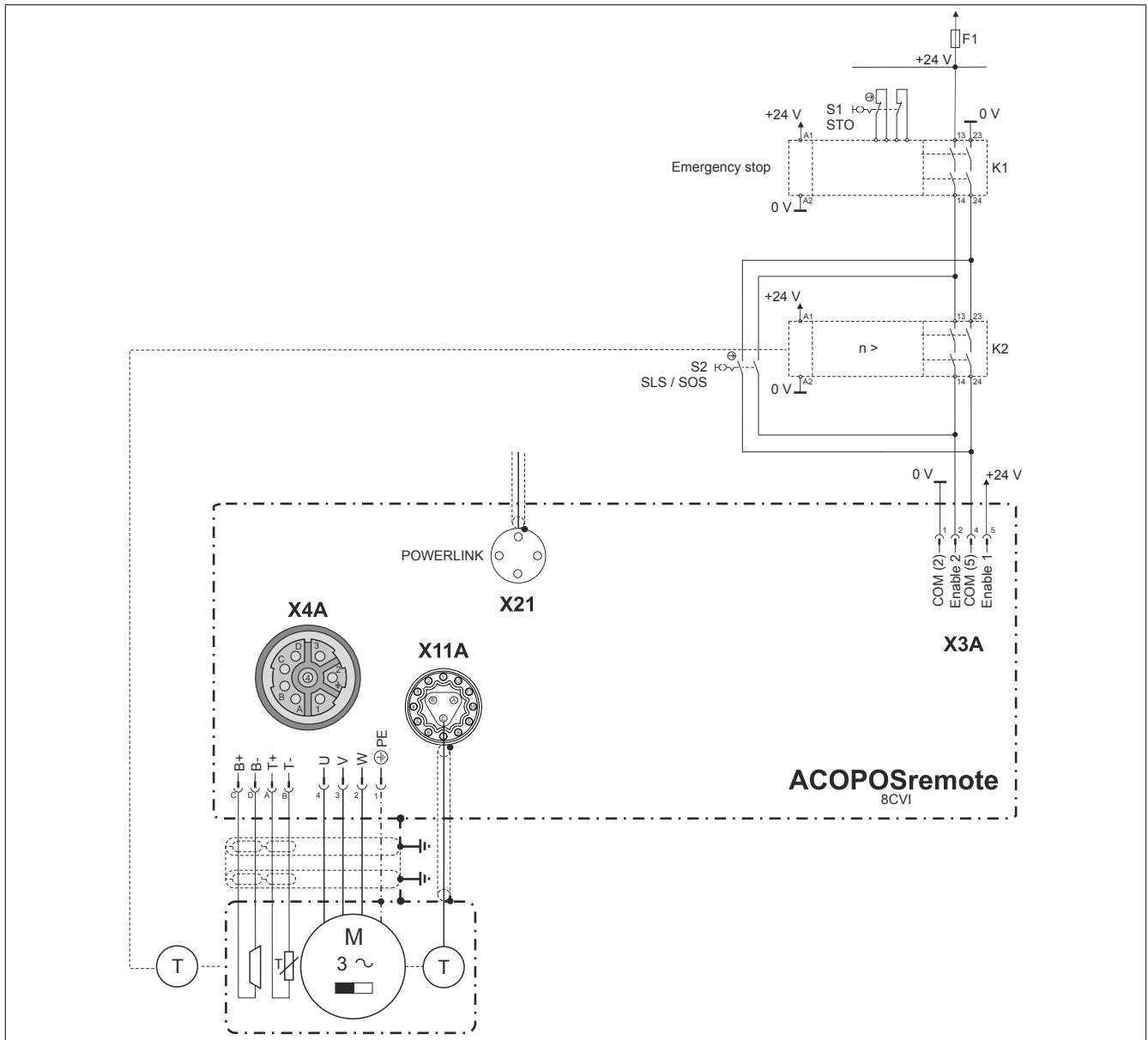

Figure 88: STO, SLS, SOS - Safety Category 4 / SIL 3 / PL e

#### Danger!

The brake shown in this image as well as brake control from the 8CVI module are not included in the safety function!

## 8DI

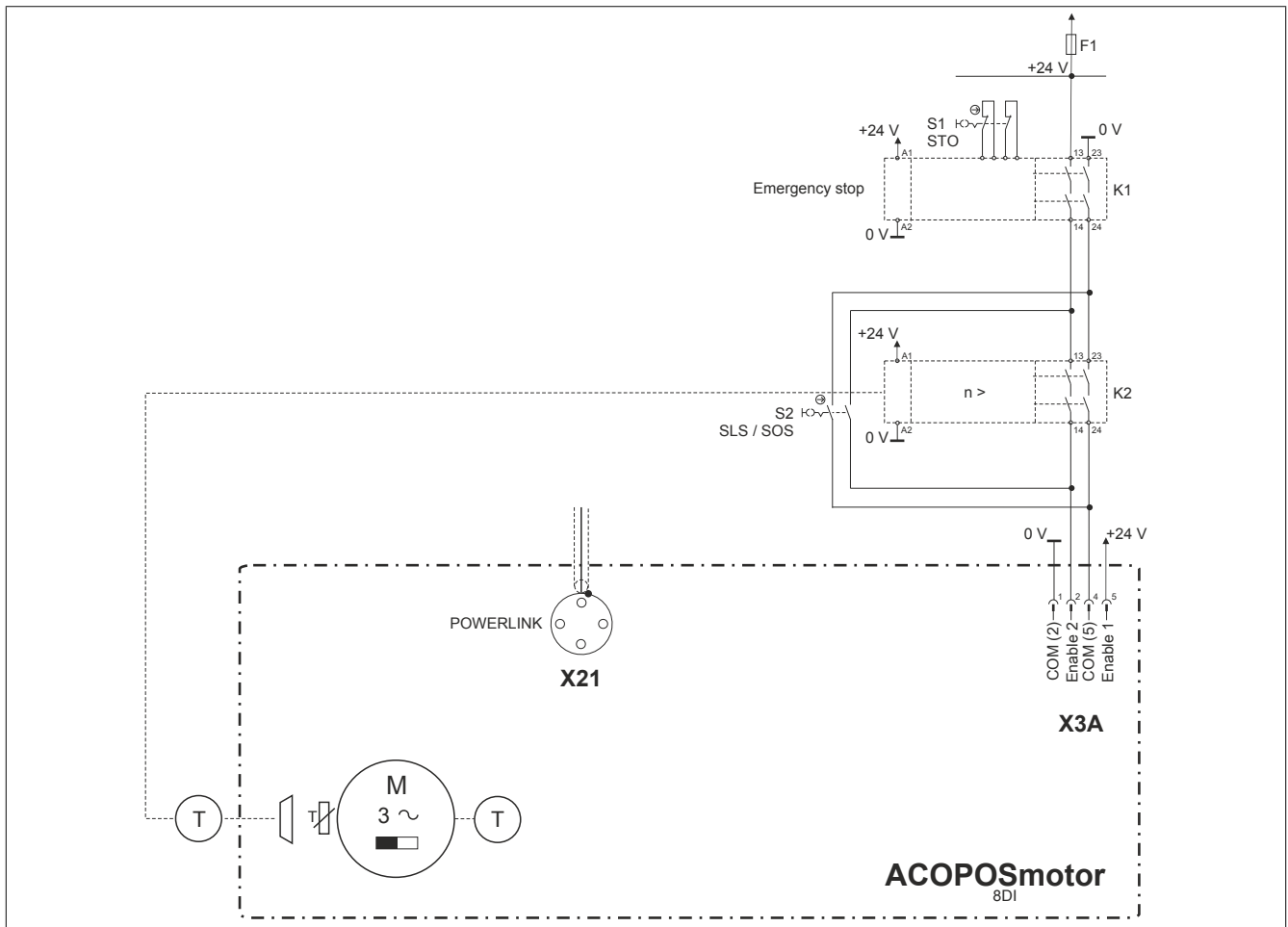

Figure 89: STO, SLS, SOS - Safety Category 4 / SIL 3 / PL e

**Danger!**

The brake shown in this image as well as brake control from the 8DI module are not included in the safety function!

**STO**

Activating the S1 E-stop switch de-energizes the switching contacts of the K1 E-stop switching device. This cuts off the two enable inputs on the 8CVI or 8DI module. As a result, the supply of power to the motor is cut off.

This ensures that the supply of power to the motor is always cut off immediately.

**SLS**

Opening the S2 switch activates the SLS safety function. The switching contacts of the K2 overspeed monitor are opened if the monitor's set speed limit is exceeded. This cuts off the two enable inputs on the 8CVI or 8DI module. As a result, the supply of power to the motor is cut off.

This ensures that the supply of power to the motor is always cut off immediately when the speed limit set on the K2 overspeed monitor is exceeded.

## SOS

Opening the S2 switch activates the SOS safety function. The switching contacts of the K2 standstill monitor are opened when the standstill monitor is activated. This cuts off the two enable inputs on the 8CVI or 8DI module. As a result, the supply of power to the motor is cut off.

This ensures that the supply of power to the motor is always cut off immediately when the K2 standstill monitor is activated.

### **Information:**

Either the SLS or the SOS safety function can be implemented depending on the function of the K2 switching device (overspeed monitor or standstill monitor).

### **Danger!**

The S1 and S2 switches shown require the use of a two-pin Category 4 / SIL 3 / PL e switching device with a positively driven N.C. contact in accordance with EN 60947-5-1. A two-pin Category 4 / SIL 3 / PL e E-stop switching device must be used for the K1 and K2 relays shown.

The instructions in the switching device's user documentation must be observed!

## 7.1.1.4.2 SS1, SLS, SS2 - Safety Category 4 / SIL 3 / PL e (Variant A)

## 8CVI

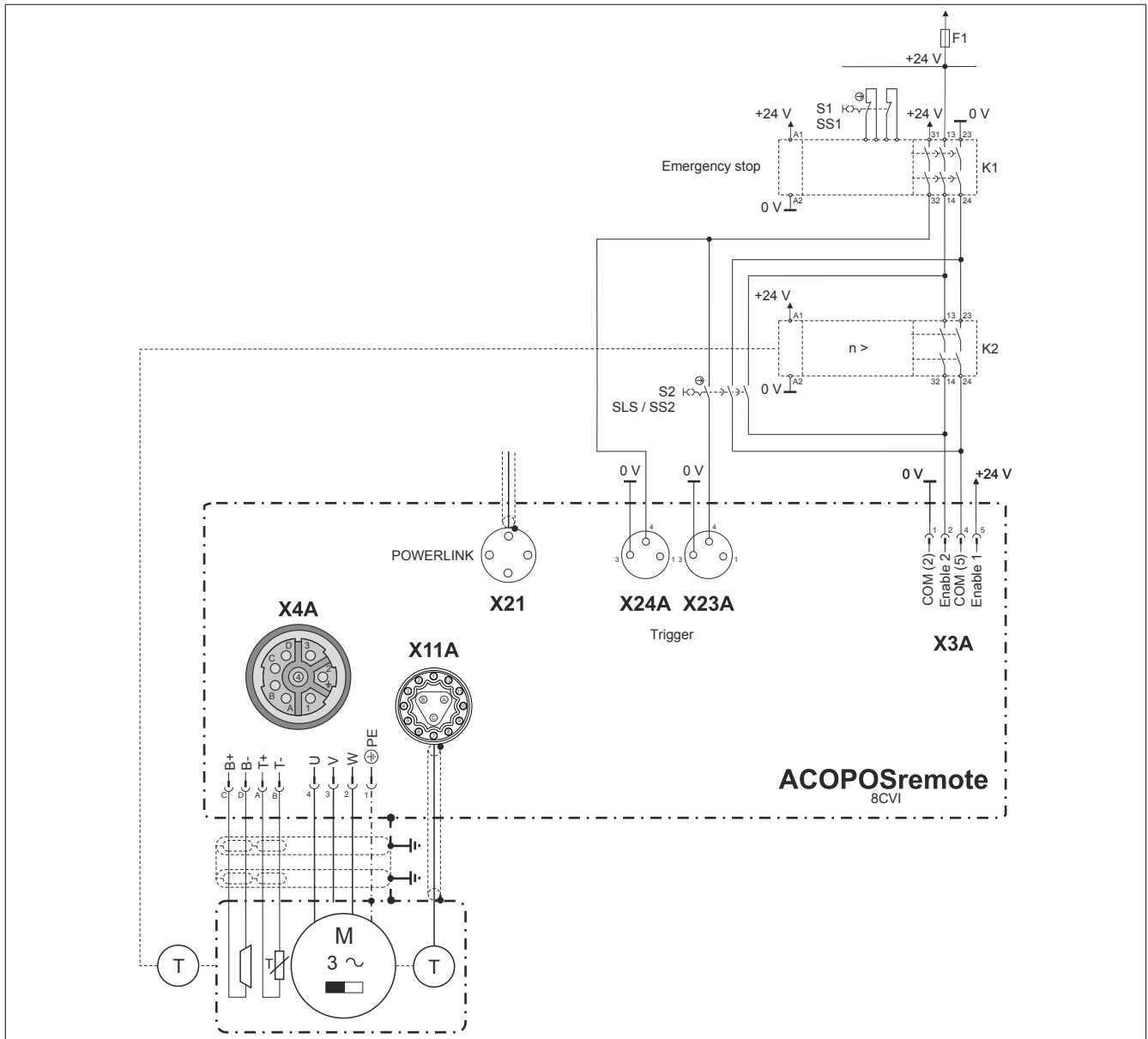

Figure 90: SS1, SLS, SS2 - Safety Category 4 / SIL 3 / PL e (Variant A)

**Danger!**

The brake shown in this image as well as brake control from the 8CVI module are not included in the safety function!

**Information:**

For this circuit, the X24A / Trigger input on the 8CVI module must be configured as a quick-stop for the affected axis.

8DI

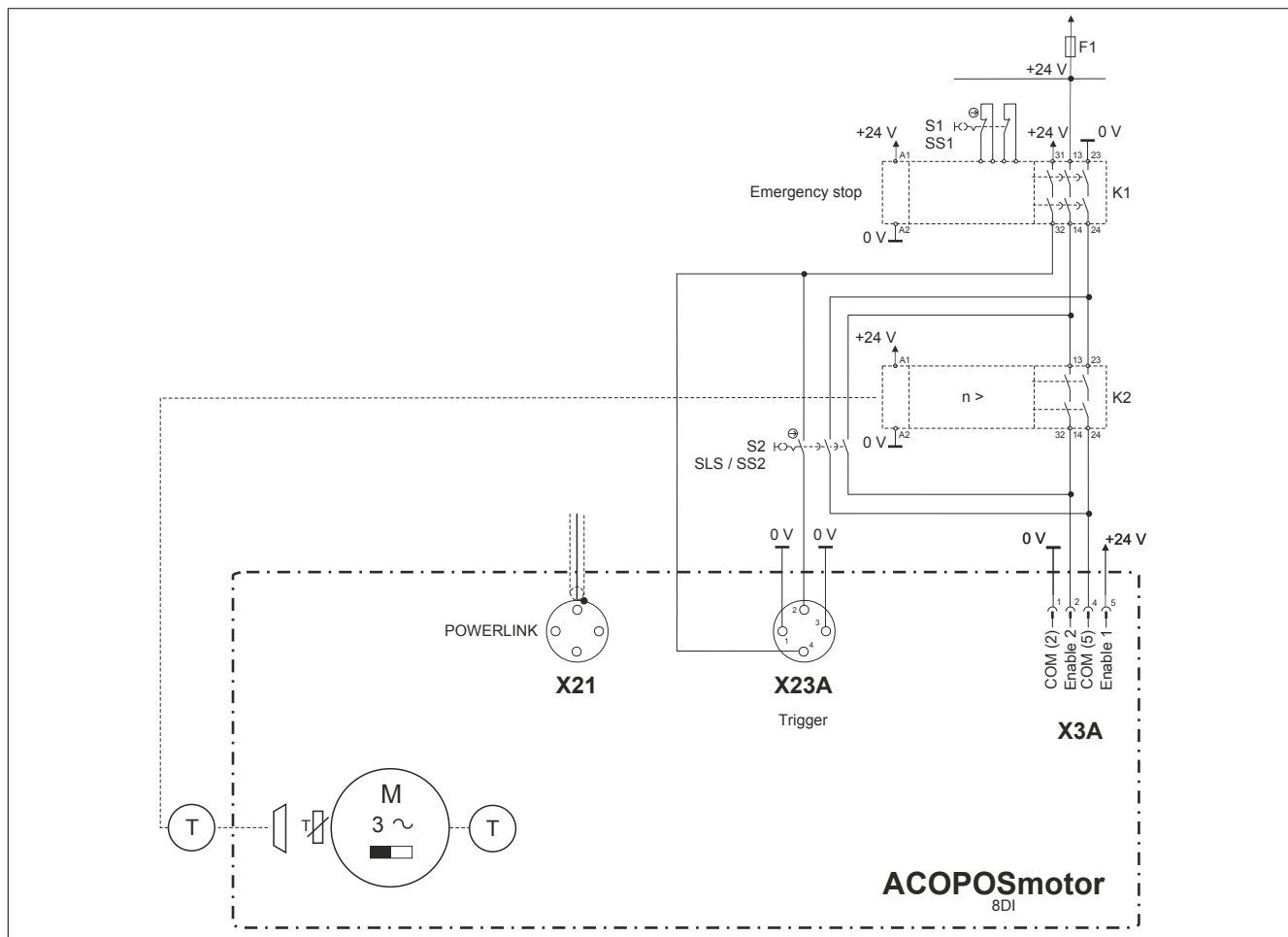

Figure 91: SS1, SLS, SS2 - Safety Category 4 / SIL 3 / PL e (Variant A)

**Danger!**

The brake shown in this image as well as brake control from the 8DI module are not included in the safety function!

**Information:**

For this circuit, the X23A / Trigger2 input on the 8DI module must be configured as a quick-stop for the affected axis.

**SS1**

Activating the S1 E-stop switch triggers an active braking procedure via an undelayed switching contact of the K1 E-stop switching device on the X24A / Trigger input of the 8CVI inverter module or the X23A / Trigger2 input of the 8DI module. The delayed switching contacts of the K1 E-stop switching device are de-energized after a defined amount of time. This cuts off the two enable inputs on the 8CVI or 8DI module. As a result, the supply of power to the motor is cut off.

This ensures that the supply of power to the motor is always cut off after a defined amount of time.

**SLS**

Opening the S2 switch activates the SLS safety function and triggers an active braking procedure on the X23A / Trigger input of the 8CVI inverter module or the X23A / Trigger1 input of the 8DI module. After a defined amount of time, speed monitoring is activated on the K2 overspeed monitor. If the speed limit is exceeded, then the two enable inputs of the 8CVI or 8DI module are disconnected via the undelayed switching contacts of the K2 overspeed monitor. As a result, the supply of power to the motor is cut off.

This ensures that the supply of power to the motor is always cut off immediately when the speed limit set on the K2 overspeed monitor is exceeded.

## SS2

Opening the S2 switch activates the SS2 safety function and triggers an active braking procedure on the X23A / Trigger input of the 8CVI inverter module or the X23A / Trigger1 input of the 8DI module. After a defined amount of time, standstill monitoring is activated on the K2 standstill monitor. If the tolerance limit is exceeded (standstill monitor K2 is activated), then the enable inputs of the 8CVI or 8DI module are disconnected via the undelayed switching contacts of the K2 standstill monitor. As a result, the supply of power to the motor is cut off.

This ensures that the supply of power to the motor is always cut off immediately when the K2 standstill monitor is activated.

### **Information:**

Either the SLS or the SS2 safety function can be implemented depending on the function of the K2 switching device (overspeed monitor or standstill monitor).

### **Danger!**

The S1 and S2 switches shown require the use of a two-pin Category 4 / SIL 3 / PL e switching device with a positively driven N.C. contact in accordance with EN 60947-5-1. A two-pin Category 4 / SIL 3 / PL e E-stop switching device must be used for the K1 and K2 relays shown.

The instructions in the switching device's user documentation must be observed!

7.1.1.4.3 SS1, SLS, SS2 - Safety Category 4 / SIL 3 / PL e (Variant B)

8CVI

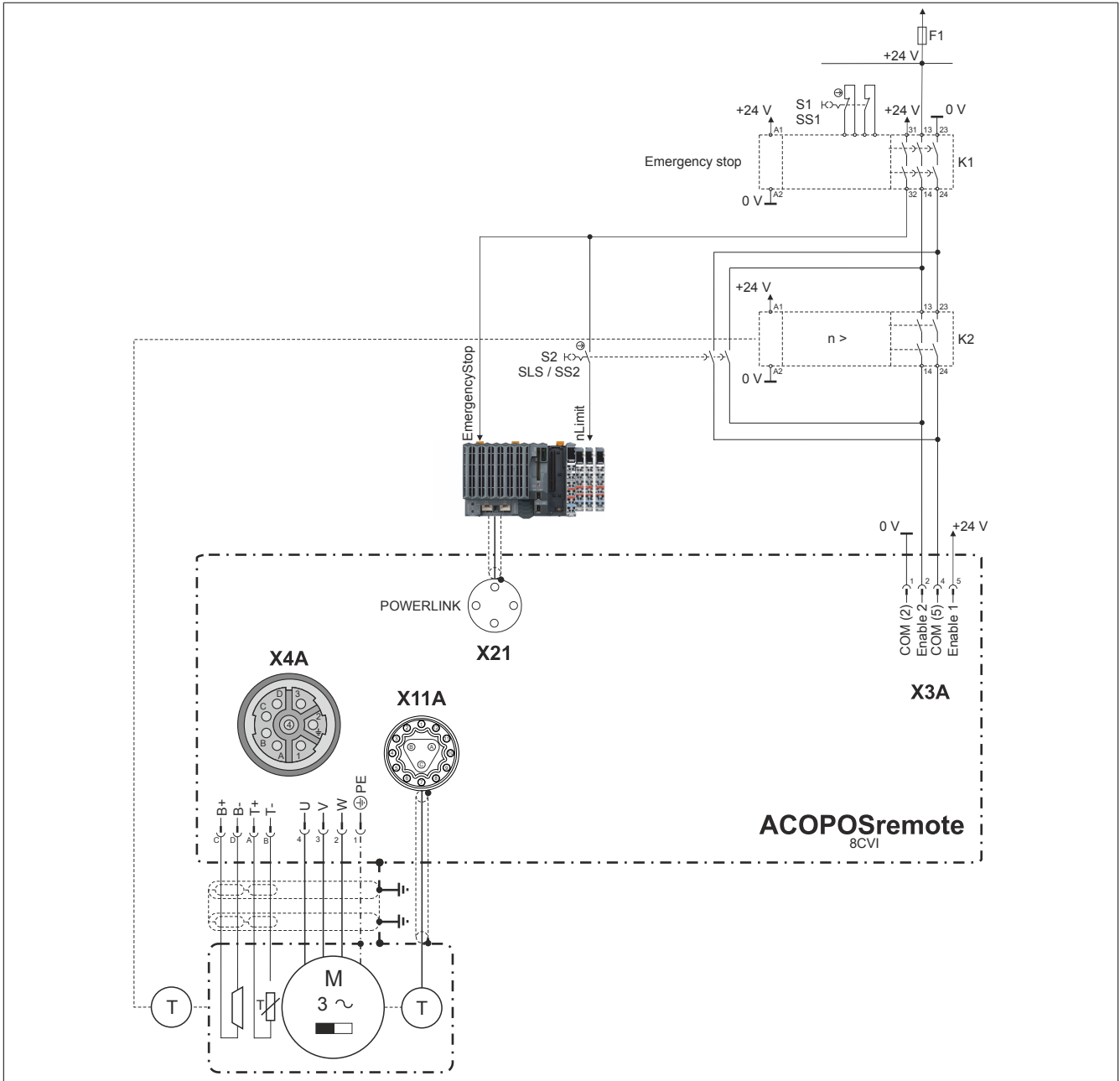

Figure 92: SS1, SLS, SS2 - Safety Category 4 / SIL 3 / PL e (Variant B)

**Danger!**

The brake shown in this image as well as brake control from the 8CVI module are not included in the safety function!

## 8DI

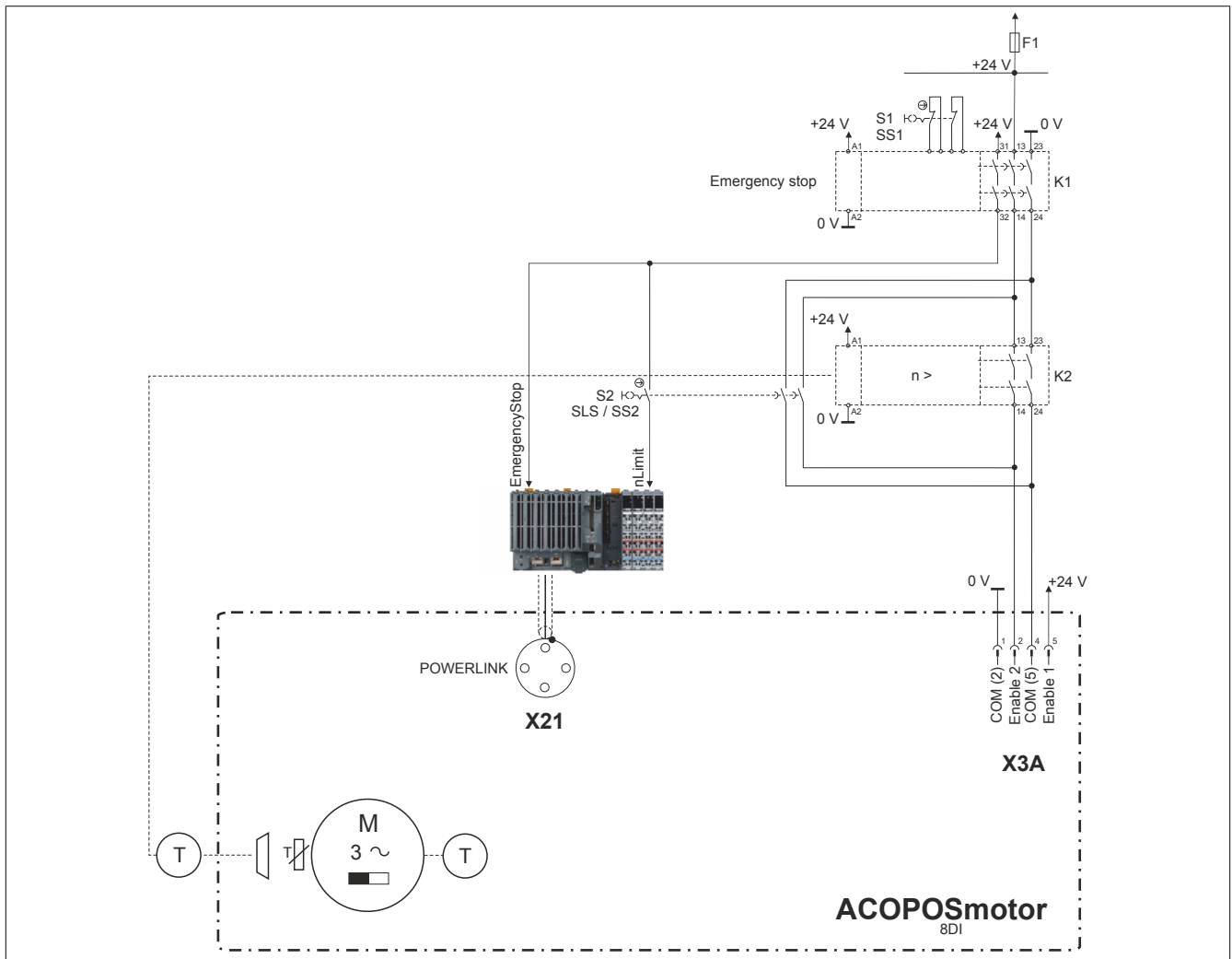

Figure 93: SS1, SLS, SS2 - Safety Category 4 / SIL 3 / PL e (Variant B)

**Danger!**

The brake shown in this image as well as brake control from the 8DI module are not included in the safety function!

**SS1**

Activating emergency switch-off S1 triggers an active braking procedure over the POWERLINK network via an undelayed switching contact of emergency switching-off device K1 on digital input "EmergencyStop" on the controller (see "Code example" on page 325). After a defined amount of time, the delayed switching contacts of emergency switching-off device K1 are de-energized. This disconnects the two enable inputs of the 8CVI module or 8DI module. The supply of power to the motor is cut off as a result.

This ensures that the supply of power to the motor is always cut off after a defined amount of time.

## SLS

Opening switch S2 activates safety function SLS and triggers active braking via the POWERLINK network on digital input "nLimit" on the controller (see "Code example" on page 325). After a defined amount of time, speed monitoring is activated on overspeed monitor K2. If the configured speed limit is exceeded, then the two enable inputs of the 8CVI module or 8DI module are cut off via the undelayed switching contacts of overspeed monitor K2. The supply of power to the motor is cut off as a result.

This ensures that the supply of power to the motor is always cut off immediately when the speed limit set on the K2 overspeed monitor is exceeded.

## SS2

Opening switch S2 activates safety function SS2 and triggers an active braking procedure via the POWERLINK network on digital input "nLimit" on the controller (see "Code example" on page 325). After a defined amount of time, standstill monitoring is activated on standstill monitor K2. If the configured tolerance limit is exceeded (standstill monitor K2 is activated), then the two enable inputs of the 8CVI module or 8DI module are cut off via the undelayed switching contacts of standstill monitor K2. The supply of power to the motor is cut off as a result.

This ensures that the supply of power to the motor is always cut off immediately when the K2 standstill monitor is activated.

### Information:

Either the SLS or the SS2 safety function can be implemented depending on the function of the K2 switching device (overspeed monitor or standstill monitor).

### Danger!

The S1 and S2 switches shown require the use of a two-pin Category 4 / SIL 3 / PL e switching device with a positively driven N.C. contact in accordance with EN 60947-5-1. A two-pin Category 4 / SIL 3 / PL e E-stop switching device must be used for the K1 and K2 relays shown.

The instructions in the switching device's user documentation must be observed!

**Code example**

Issuing the stop command via POWERLINK:

```

if ( ! statStopActive )
{
    /* Move stop not active: check move stop inputs */
    if ( DI_EmergencyStop == INPUT_LEVEL_LOW )
    {
        /* Move stop with emergency stop deceleration */
        MC_Stop_0.Deceleration = E_STOP_DECELERATION;
        MC_Stop_0.Execute = 1;
        statStopActive = 1;
    }
    else if ( cmdStopAxis1 )
    {
        /* Move stop with application deceleration */
        MC_Stop_0.Deceleration = APPLICATION_DECELERATION;
        MC_Stop_0.Execute = 1;
        statStopActive = 1;
    }
}
else
{
    /* Move stop is active, wait until it is finished */
    if ( DI_EmergencyStop == INPUT_LEVEL_HIGH &&
        cmdStopAxis1 == 0 &&
        MC_Stop_0.Done == 1 )
    {
        /* Move stop complete */
        MC_Stop_0.Execute = 0;
        statStopActive = 0;
    }
}
...
MC_Stop_0.Axis = AxisRef1;
MC_Stop( &MC_Stop_0 );
...

```



## 8DI

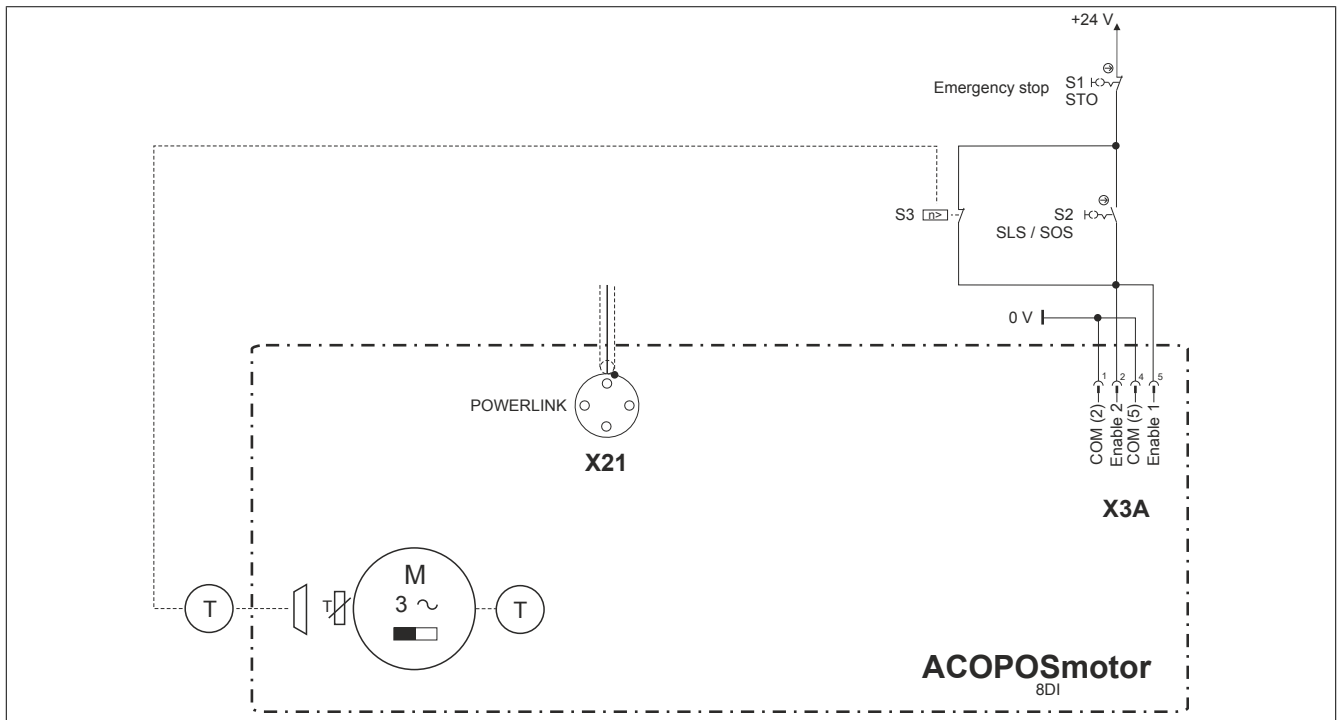

Figure 95: STO, SLS, SOS - Safety Category 3 / SIL 2 / PL d

**Danger!**

The brake shown in this image as well as brake control from the 8DI module are not included in the safety function!

**STO**

Activating the S1 E-stop switch disconnects both of the 8CVI or 8DI module's enable inputs. As a result, the supply of power to the motor is cut off.

This ensures that the supply of power to the motor is always cut off immediately.

**SLS**

Opening the S2 switch activates the SLS safety function. The switching contact of the S3 overspeed monitor is opened if the monitor's configured speed limit is exceeded. This cuts off the two enable inputs on the 8CVI or 8DI module. As a result, the supply of power to the motor is cut off.

This ensures that the supply of power to the motor is always cut off immediately when the speed limit set on the S3 overspeed monitor is exceeded.

**SOS**

Opening the S2 switch activates the SOS safety function. The switching contact of the overspeed monitor is opened when the S3 standstill monitor is activated. This cuts off the two enable inputs on the 8CVI or 8DI module. As a result, the supply of power to the motor is cut off.

This ensures that the supply of power to the motor is always cut off immediately when the S3 standstill monitor is activated.

**Information:**

Either the SLS or the SOS safety function can be implemented depending on the function of the S3 switching device (overspeed monitor or standstill monitor).

## **Danger!**

The S1 and S2 switches shown require the use of one-pin Category 3 / SIL 2 / PL d switching devices with a positively-driven N.C. contact in accordance with EN 60947-5-1. A one-pin Category 3 / SIL 2 / PL d switching device must be used for the S3 switching device shown.

The guidelines in the switching device's user documentation must be observed!

7.1.1.4.5 SS1, SLS, SS2 - Safety Category 3 / SIL 2 / PL d (Variant A)

8CVI

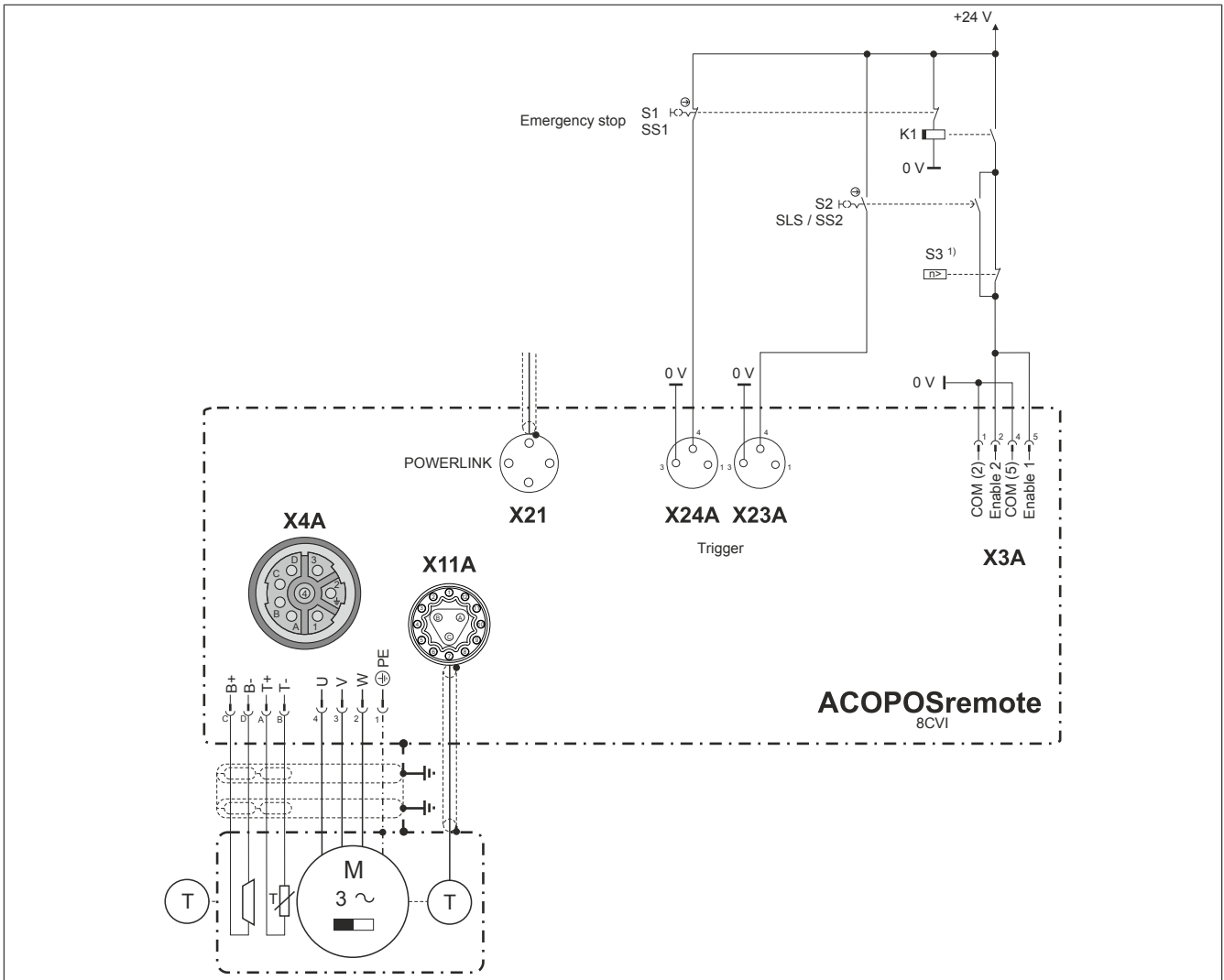

Figure 96: SS1, SLS, SS2 - Safety Category 3 / SIL 2 / PL d (Variant A)

**Danger!**

The brake shown in this image as well as brake control from the 8CVI module are not included in the safety function!

**Information:**

For this circuit, the X24A / Trigger input on the 8CVI module must be configured as a quick-stop for the affected axis.

## 8DI

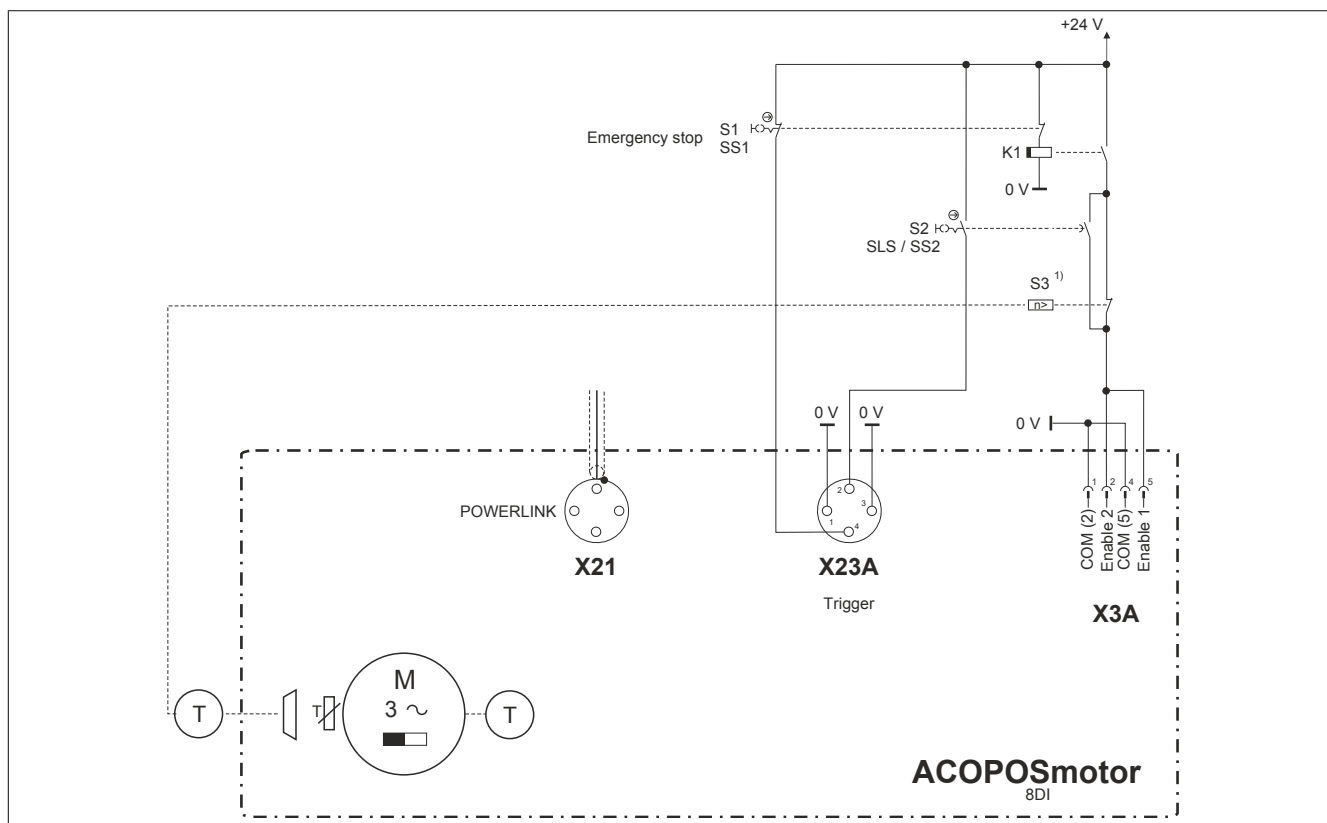

Figure 97: SS1, SLS, SS2 - Safety Category 3 / SIL 2 / PL d (Variant A)

**Danger!**

The brake shown in this image as well as brake control from the 8DI module are not included in the safety function!

**Information:**

For this circuit, the X23A / Trigger2 input on the 8DI module must be configured as a quick-stop for the affected axis.

**SS1**

Pressing the S1 E-stop button de-energizes the K1 relay. This triggers an active braking procedure via the X24A / Trigger input on the 8CVI module or the X23A / Trigger2 input on the 8DI module.

The K1 auxiliary drop-out delay relay is de-energized after a defined amount of time. This cuts off the two enable inputs on the 8CVI or 8DI module. As a result, the supply of power to the motor is cut off.

This ensures that the supply of power to the motor is always cut off after a defined amount of time.

**SLS**

Opening the S2 switch activates the SLS safety function and triggers an active braking procedure via the X23A / Trigger input on the 8CVI inverter module or the X23A / Trigger1 input on the 8DI module. After a defined amount of time, speed monitoring is activated on the S3 overspeed monitor. If the speed limit is exceeded, then the two enable inputs of the 8CVI or 8DI module are disconnected via the undelayed switching contact of the S3 overspeed monitor. As a result, the supply of power to the motor is cut off.

This ensures that the supply of power to the motor is always cut off immediately when the speed limit set on the S3 overspeed monitor is exceeded.

## SS2

Opening the S2 switch activates the SS2 safety function and triggers an active braking procedure via the X23A / Trigger input on the 8CVI inverter module or the X23A / Trigger1 input on the 8DI module. After a defined amount of time, standstill monitoring is activated on the S3 standstill monitor. If the set tolerance limit is exceeded (standstill monitor S3 is activated), then the two enable inputs of the 8CVI or 8DI module are disconnected via the undelayed switching contact of the S3 standstill monitor. As a result, the supply of power to the motor is cut off.

This ensures that the supply of power to the motor is always cut off immediately when the S3 standstill monitor is activated.

### **Information:**

Either the SLS or the SS2 safety function can be implemented depending on the function of the S3 switching device (overspeed monitor or standstill monitor).

### **Danger!**

The S1 and S2 switches shown require the use of one-pin Category 3 / SIL 2 / PL d switching devices with a positively-driven N.C. contact in accordance with EN 60947-5-1. A one-pin Category 3 / SIL 2 / PL d switching device must be used for the K1 relay shown as well as the S3 switching device.

The instructions in the switching device's user documentation must be observed!

7.1.1.4.6 SS1, SLS, SS2 - Safety Category 3 / SIL 2 / PL d (Variant B)

8CVI

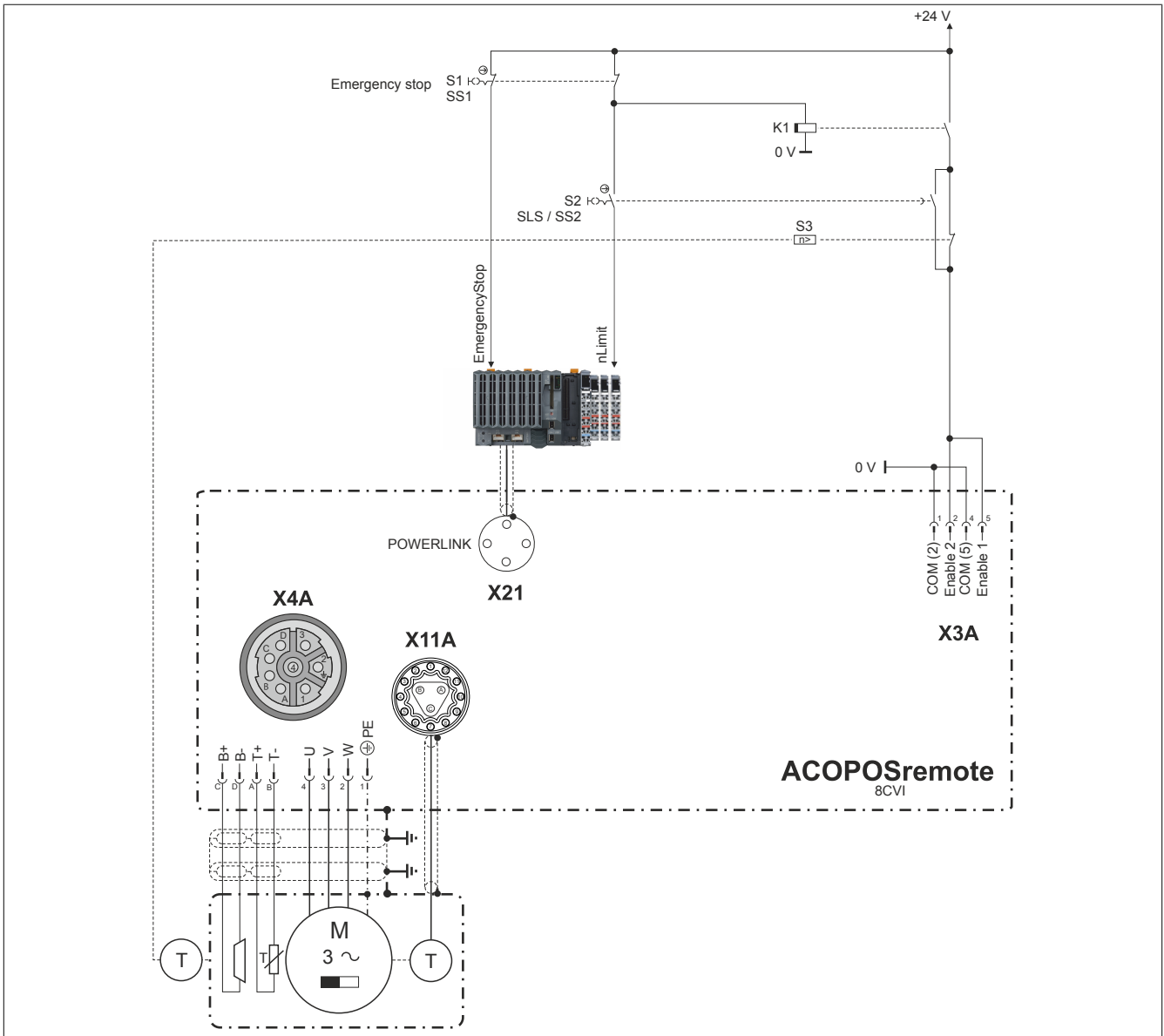

Figure 98: SS1, SLS, SS2 - Safety Category 3 / SIL 2 / PL d (Variant B)

**Danger!**

The brake shown in this image as well as brake control from the 8CVI module are not included in the safety function!

## 8DI

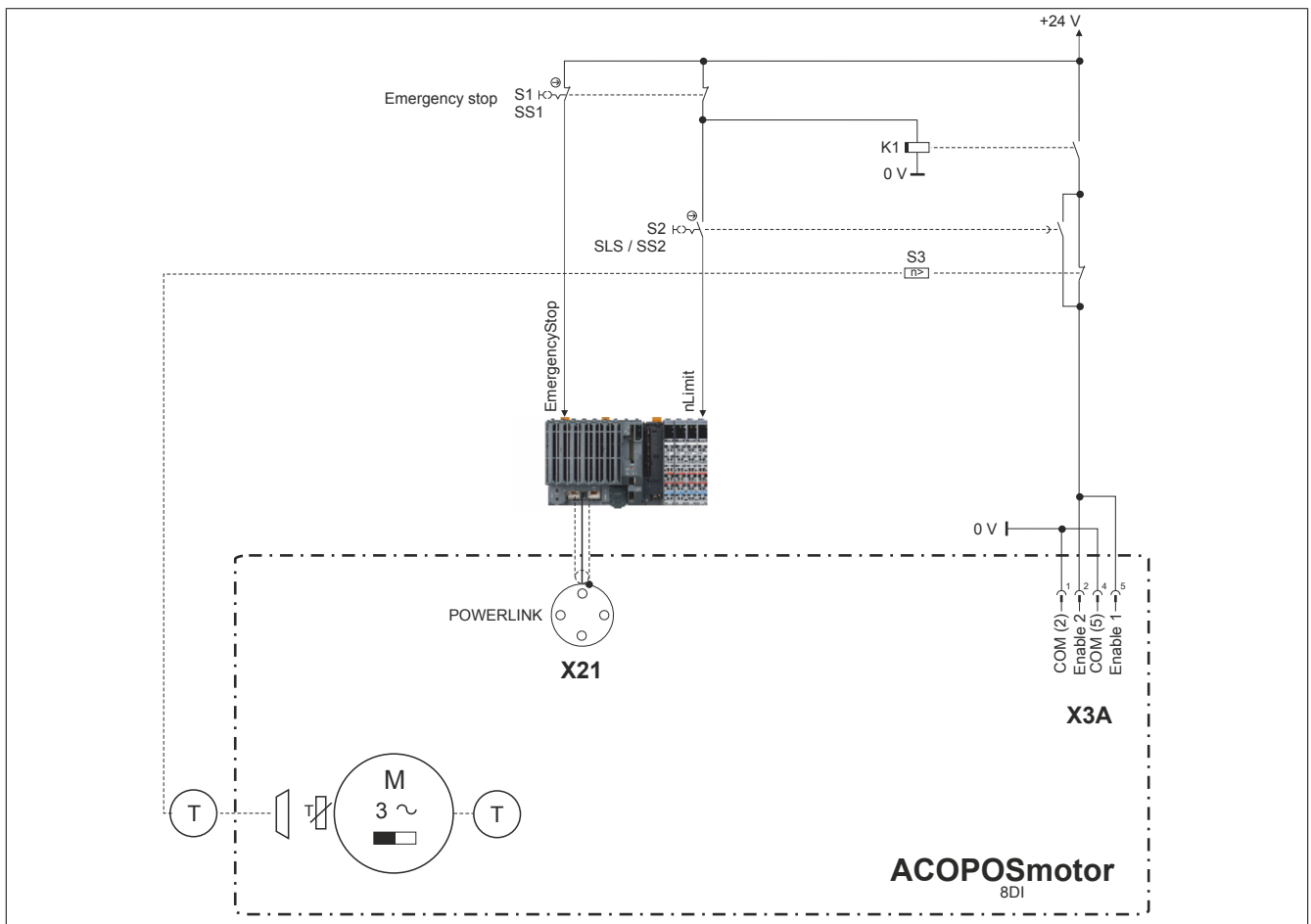

Figure 99: SS1, SLS, SS2 - Safety Category 3 / SIL 2 / PL d (Variant B)

**Danger!**

The brake shown in this image as well as brake control from the 8DI module are not included in the safety function!

**SS1**

Activating emergency switch-off S1 triggers an active braking procedure via digital input "EmergencyStop" on the controller (see "Code example" on page 325).

The K1 auxiliary drop-out delay relay is de-energized after a defined amount of time. This cuts off the two enable inputs on the 8CVI or 8DI module. As a result, the supply of power to the motor is cut off.

This ensures that the supply of power to the motor is always cut off after a defined amount of time.

**SLS**

Opening switch S2 activates safety function SLS and triggers an active braking procedure via digital input "nLimit" on the controller (see "Code example" on page 325). After a defined amount of time, speed monitoring is activated on overspeed monitor S3. If the configured speed limit is exceeded, then the two enable inputs of the 8CVI module or 8DI module are cut off via the undelayed switching contact of overspeed monitor S3. The supply of power to the motor is cut off as a result.

This ensures that the supply of power to the motor is always cut off immediately when the speed limit set on the S3 overspeed monitor is exceeded.

**SS2**

Opening switch S2 activates safety function SS2 and triggers an active braking procedure via digital input "nLimit" on the controller (see "Code example" on page 325). After a defined amount of time, standstill monitoring is activated on standstill monitor S3. If the configured tolerance limit is exceeded (standstill monitor S3 is activated), then the two enable inputs of the 8CVI module or 8DI module are cut off via the undelayed switching contact of standstill monitor S3. The supply of power to the motor is cut off as a result.

This ensures that the supply of power to the motor is always cut off immediately when the S3 standstill monitor is activated.

Either the SLS or the SS2 safety function can be implemented depending on the function of the S3 switching device (overspeed monitor or standstill monitor).

**Danger!**

**The S1 and S2 switches shown require the use of two or one-pin switching devices (Category 3 / SIL 2 / PL d) with a positively driven N.C. contact in accordance with EN 60947-5-1. A one-pin Category 3 / SIL 2 / PL d switching device must be used for the K1 relay shown as well as the S3 switching device.**

**The instructions in the switching device's user documentation must be observed!**

**Code example**

Issuing the stop command via POWERLINK:

```

if ( ! statStopActive )
{
    /* Move stop not active: check move stop inputs */
    if ( DI_EmergencyStop == INPUT_LEVEL_LOW )
    {
        /* Move stop with emergency stop deceleration */
        MC_Stop_0.Deceleration = E_STOP_DECELERATION;
        MC_Stop_0.Execute = 1;
        statStopActive = 1;
    }
    else if ( cmdStopAxis1 )
    {
        /* Move stop with application deceleration */
        MC_Stop_0.Deceleration = APPLICATION_DECELERATION;
        MC_Stop_0.Execute = 1;
        statStopActive = 1;
    }
}
else
{
    /* Move stop is active, wait until it is finished */
    if ( DI_EmergencyStop == INPUT_LEVEL_HIGH &&
        cmdStopAxis1 == 0 &&
        MC_Stop_0.Done == 1 )
    {
        /* Move stop complete */
        MC_Stop_0.Execute = 0;
        statStopActive = 0;
    }
}
...
MC_Stop_0.Axis = AxisRef1;
MC_Stop( &MC_Stop_0 );
...

```

**7.1.2 SafeMOTION - Functional safety technology**

For information about SafeMOTION functional safety technology, see chapter 5 "System characteristics" and chapter 6 "Safety technology" (sections 6.1 to 6.4) of SafeMOTION user's manual MAACPMSAFEMC-xxx.

## 7.2 ACOPOSmotor Compact

### 7.2.1 Standard safety technology ("hardwired safety technology")

Motor-integrated ACOPOSmotor Compact (8D1) drives with standard safety technology implement safety function Safe Torque Off (STO) per EN 61800-5-2. The cutoff corresponds to stop category 0 per EN 60204-1.

Safety functions SS1, SS2, SLS, SOS (EN 61800-5-2) and stop categories 1 and 2 (EN 60204-1) can also be implemented through the use of additional components (time relays, speed monitors, etc.) (see "Wiring the enable inputs per required safety category / SIL / PL and functionality (STO, SS1, SS2, SLS, SOS)" on page 343).

#### Caution!

**Safety function STO does not protect against faults that occur in non-safety-related functions of motor-integrated ACOPOSmotor Compact drives with standard safety technology!**

#### Danger!

**Especially in the area of safety technology, always consult the most current version of this document on the B&R website for valid specifications ([www.br-automation.com](http://www.br-automation.com))! The specifications in this version of the document are not necessarily current. The user must verify the correctness of specifications before implementing safety functions!**

#### 7.2.1.1 General information

Safety function STO (safe pulse disabling) is integrated in 8D1 modules for safe stopping. This is designed to satisfy the following safety classifications depending on the external wiring: <sup>13)</sup>

Criteria	Characteristic values <sup>2)</sup>
	ACOPOSmotor Compact (8D1)
Maximum safety category per EN ISO 13849	Cat. 3
Maximum performance level per EN ISO 13849	PL e
Maximum safety integrity level per IEC 61800-5-2	SIL 3
Maximum safety integrity level per IEC 62061	SIL 3
Maximum safety integrity level per IEC 61508	SIL 3
PFH (probability of dangerous failure per hour)	$<6 \cdot 10^{-9}$
PFD (probability of dangerous failure on demand) depending on the proof test interval (PTI) For a PTI of 20 years	$<4 \cdot 10^{-4}$
PTI (proof test interval) <sup>1)</sup>	Max. 20 years
DC (diagnostic coverage)	>90%
Diagnostic test interval	Max. 3 months
MTTFd (mean time to dangerous failure)	>500 years

Table 188: Safety classifications, criteria and characteristic values for safety function STO

1) Corresponds to the mission time of the module.

2) These characteristic values are only valid if a diagnostic test interval of max. 3 months is observed - see "Testing" (Page 337).

The following table provides an overview of the individual safety functions that can be implemented:

Name according to standard		Short description
EN 61800-5-2	EN 60204-1	
STO (Safe Torque Off)	Stop category 0	Cuts off the power supply
SS1 (Safe Stop 1)	Stop category 1	Initiates active braking and activates function STO after a defined amount of time has passed
SS2 (Safe Stop 2)	Stop category 2	Initiates active braking and activates function SOS after a defined amount of time has passed
SLS (Safely Limited Speed)	---	Protection against exceeding a defined speed limit
SOS (Safe Operating Stop)	---	Protection against impermissible position deviation

Table 189: Overview of safety functions according to standards

Safety function STO (safe pulse disabling) interrupts the power supply to the motor by preventing the pulses to the power output stage over two channels. This means that a rotating field and thus electrical torque can no longer be built up in 8D1 modules.

As a result, the requirements regarding the stop functions of category 0 per EN 60204-1 are met with safety function STO present. With the use of additional components, the requirements of category 1 per EN 60204-1 are also met. Both stop functions require switching off the power supply to the machine drive elements (immediately for category 0 and after reaching standstill for category 1).

The terminology of EN 61800-5-2 (STO, SS1, SS2, SLS, SOS) will be used in the following.

<sup>13)</sup> For detailed information about the listed standards and safety functions, see section [Standards and certifications](#).

## **Danger!**

If the safety functions integrated in the drive system are used in an application, then the safety functions must be fully validated before the drive system is switched on for the first time. There is a risk of death, serious injury or damage to property.

## **Information:**

If module-internal hardware errors occur, safety function STO switches to the safe state and interrupts the supply of power to the drive (failsafe principle). If a hardware defect occurs, then the entire module must be replaced.

### 7.2.1.2 Principle - Implementing the safety function

Safety function STO (safe pulse disabling) is achieved by interrupting the pulse patterns to the power output stage in the ACOPOSmotor Compact. The internal power supply for the drivers ( $V_{CC_{HS}}/V_{CC_{LS}}$ ) is safely switched via terminals "Enable signal+" and "Enable signal-" so that the pulse patterns can be transferred to the power output stage.

#### 8D1

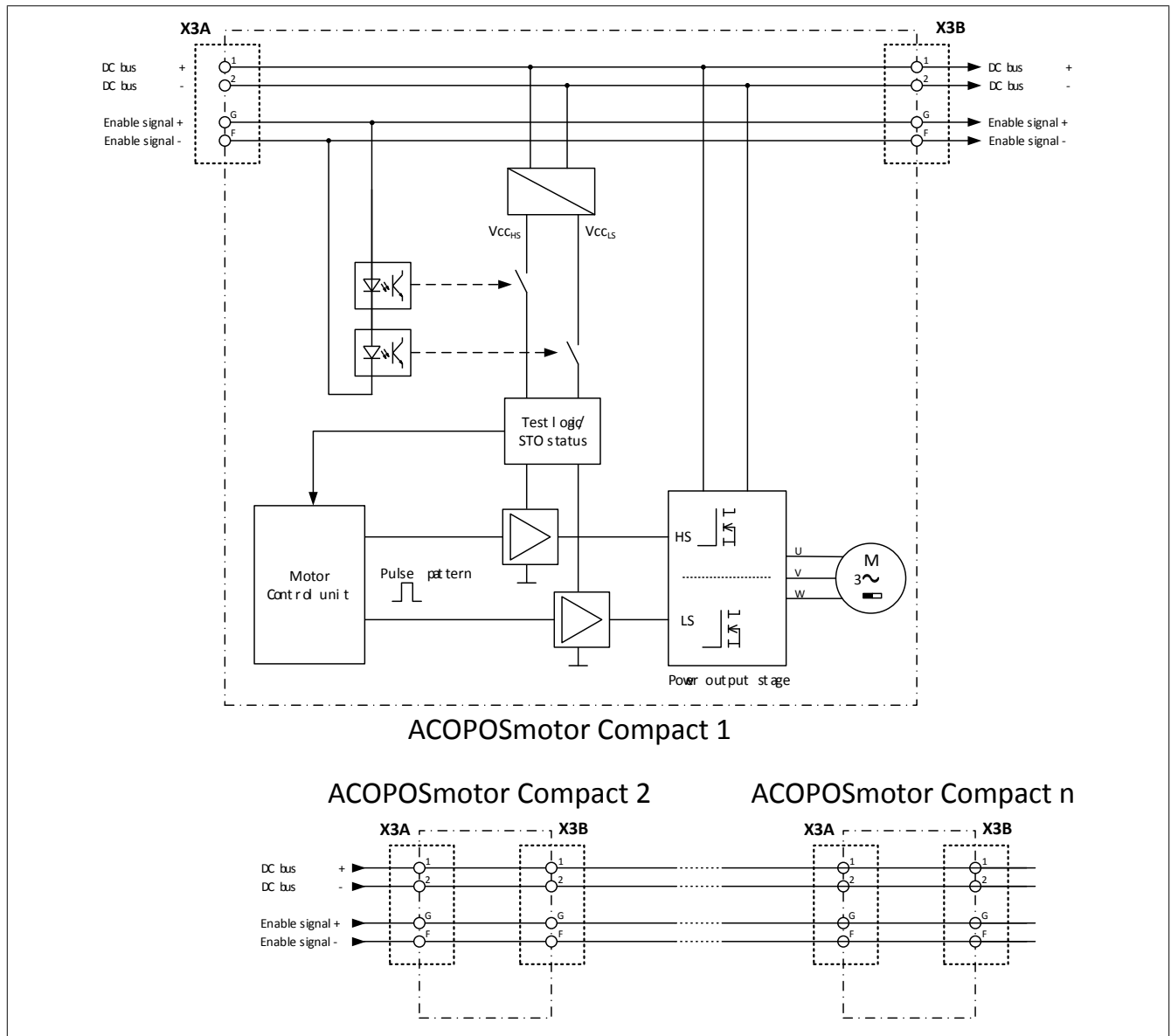

Figure 100: Block diagram of safety function STO - 8D1

If control at the "Enable signal+" and "Enable signal-" terminals drops out, the driver supply is reliably interrupted and the pulse patterns are no longer transferred. It is then no longer possible to transfer the pulse pattern needed to generate the rotating field to the power output stage. This cuts off the supply of power to the motor.

#### 7.2.1.2.1 Additional functions

The presence of the driver supply voltages is queried by the control unit. If no voltage is applied, generation of the pulse patterns by the control system is also suppressed.

#### Testing

The two switches for switching off the driver power supply are checked for plausibility by test logic. Testing is active when function STO is activated. In the event of an invalid test result – e.g. due to a defective semiconductor switch – the safe state is assumed by switching off the driver power supply. This state is locked, i.e. it can only be unlocked by removing the module power supply. In the safely locked state, "Enable off" is reported as the STO status, even if the STO input is supplied with power.

To achieve the specified safety characteristics, the diagnostic test interval of max. 3 months must be observed. Since diagnostics is only active when the safety function is activated, it must be enabled cyclically. The user must perform the following test routine or automatic test for this.

### Manual test - Test routine

Step 1	Apply the module power supply or check for its presence.
Step 2	Activate STO: Low level (<5 V) between terminals "Enable signal+" and "Enable signal-"
Step 3	Deactivate STO: High level (>15 V) between terminals "Enable signal+" and "Enable signal-"
Step 4	Check for an error-free drive (STO status correct or enabling the controller possible without errors). The supply voltage is only permitted to be reapplied after this control step; otherwise, the test result loses its validity!

#### Notice!

If the drive cannot be put into service at step 4 due to a missing enable, there is a potentially dangerous error and the module must be replaced immediately or reported to B&R customer support.

#### Notice!

If an error message related to the enable input occurs during operation or after activation of safety function STO, a manual test routine must be performed.

#### Automatic test

Alternatively, the test routine can be automated by using a safe output module with OSSD functionality. The OSSD test gaps in the signal of the STO control ensure cyclic activation of the test logic, which is why the manual test routine is permitted to be omitted. In the event of a module fault, the safe state is achieved by switching off the driver power supply. The module can no longer be put into service and must be replaced.

Wiring example see Fig. 102 "STO, category 3 / SIL 3 / PL e (variant B)" on page 341

For a list of safe and compatible B&R output modules, see chapter "Connection examples" → "Connecting drive systems" → "Tested products" → "B&R" → "ACOPOSmotor Compact" in the "Integrated safety technology user's manual".

The most current version of the "Integrated safety technology user's manual" is available for download - see the B&R website ([www.br-automation.com](http://www.br-automation.com)).

#### Notice!

It is necessary to configure parameter "Disable OSSD = No".

### 7.2.1.3 General danger notices

#### Danger!

After activating safety function STO (safe pulse disabling) via terminals "Enable signal+" and "Enable signal-", the motor is de-energized and therefore not generating torque. If the motor was moving before safety function STO is activated, it is only stopped by a safe operational brake (if available) or by the friction of the complete system. The motor is therefore not able to hold suspended loads. Safe holding brakes must be used for this purpose.

#### Danger!

The switch-off time of the enable inputs must be taken into account since it has a substantial effect on the response time of the safety functions and therefore the remaining distances and times to be considered! In order to calculate the total safety response time, the user must validate the rundown time of the complete system!

The switch-off time for the enable inputs is listed in the technical data.

#### Danger!

Activating safety function STO (safe pulse disabling) via terminals "Enable signal+" and "Enable signal-" is not suitable for switching off voltage to the motor and therefore does not provide sufficient protection against electrical shock!

**Danger!**

Depending on the application, it is possible for the motor to restart after safety function STO (safe pulse disabling) is deactivated.

**Danger!**

The C standards relevant to applications must be observed!

**Danger!**

Note that multiple errors in the power output stage can cause a brief forward movement. Maximum angle of rotation  $\varphi$  of the motor shaft during this forward movement depends on the motor used. For permanent magnet synchronous motors,  $\varphi = 360^\circ/2p$  (for B&R 8D1 motors,  $p = 4$  so that the angle is  $45^\circ$ ).

This short forward movement can be excluded as a fault per EN ISO 13849-1, among other things due to the improbability that this would occur and due to general technical experience.

### 7.2.1.4 Wiring the enable inputs to the required safety category / SIL / PL

This section uses the example of safety function STO to illustrate the different wiring variations of the enable inputs on the 8D1 module to achieve the required safety category / SIL / PL.

#### Danger!

Any faults (e.g. cross faults) that are not detected can lead to the loss of safety functionality.

Appropriate measures must be taken to justify the exclusion of errors. For instance, faults caused by a short circuit between any two wires can be excluded per EN ISO 13849-2, appendix D.5, if one of the following conditions is met:

- The wires are permanently installed and protected against external damage (e.g. using a cable duct or armored conduit).
- The wires are installed in different plastic-sheathed cables or within an area for electrical equipment<sup>14)</sup>.
- The wires are each individually protected by a ground connection.

For more fault exclusions, see EN ISO 13849-2, appendix D.5.

#### Danger!

In order to achieve safety category 3 / SIL 3 / PL 3, it must be ensured that an individual fault does not result in loss of the safety function.

#### 7.2.1.4.1 STO, category 3 / SIL 3 / PL e (variant A)

An enable input on the 8D1 module is supplied with +24 V via a switching contact of a safe emergency switching-off device. Activating emergency switch-off S1 opens both switching contacts of the emergency switching-off device and disconnects the enable input over two channels.

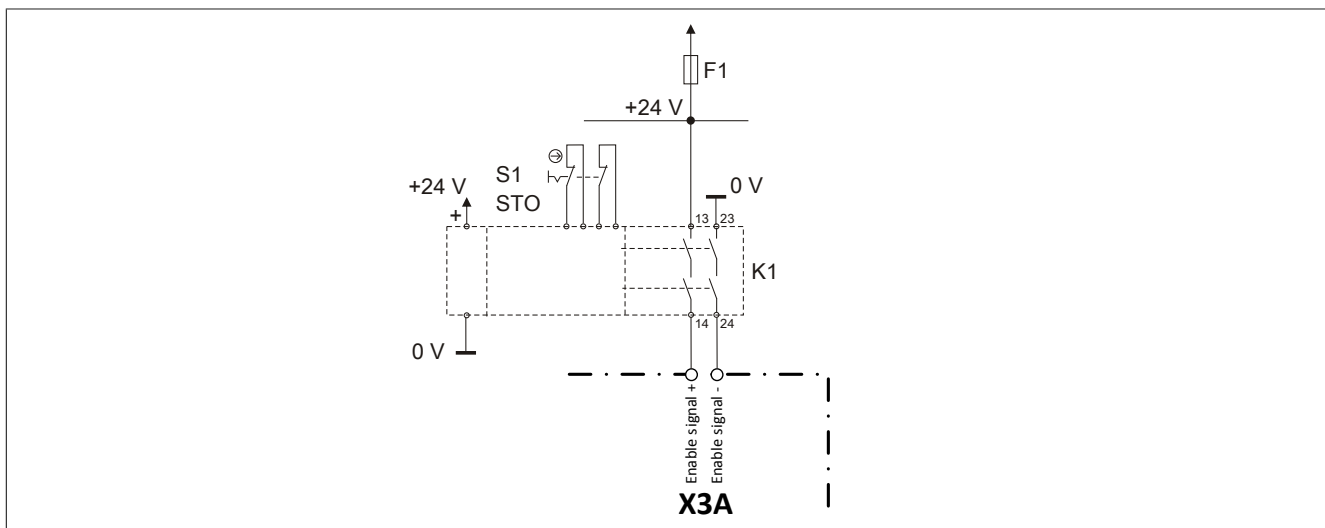

Figure 101: STO, category 3 / SIL 3 / PL e (variant A)

This circuit covers a portion of the wiring and insulation faults for the supply lines to the emergency switching-off device and to the enable inputs.

<sup>14)</sup> Prerequisite: Both the wires and the area for electrical equipment must meet the respective requirements (see IEC 60204-1).

The following fault events can occur in the external wiring:<sup>15)</sup>

Fault event	Error description	Effect
1	Interruption of the power supply cable to connection 13	Power to the motor is cut off.
2	Interruption of the power supply cable to connection 23	Power to the motor is cut off.
3	Short circuit between connections 13 and 23	Fuse F1 is triggered immediately.
4	Short circuit between connections 13 and 0 V	Fuse F1 is triggered immediately.
5	Short circuit between connections 23 and +24 V	Fuse F1 is triggered immediately.
6	Short circuit between connections 13 and 24	Fuse F1 is triggered in the operating state. Power to the motor is cut off.
7	Short circuit between connections 23 and 14	Fuse F1 is triggered in the operating state. Power to the motor is cut off.
8	<b>Short circuit between connections 13 and 14</b>	<b>Error not detected</b>
9	<b>Short circuit between connections 23 and 24</b>	<b>Error not detected</b>
10	Interruption of the power supply cable to connection 14	Power to the motor is cut off.
11	Interruption of the power supply cable to connection 24	Power to the motor is cut off.
12	Short circuit between connections 14 and 0 V	Fuse F1 is triggered in the operating state. Power to the motor is cut off.
13	Short circuit between connections 24 and +24 V	Fuse F1 is triggered in the operating state. Power to the motor is cut off.
14	<b>Short circuit between connections 14 and +24 V</b>	<b>Error not detected</b>
15	<b>Short circuit between connections 24 and +0 V</b>	<b>Error not detected</b>
16	Short circuit between connections 14 and 24	Fuse F1 is triggered in the operating state. Power to the motor is cut off.

Table 190: List of possible fault events

## Danger!

A 2-pole category 3 or 4 / SIL 3 / PL e switching device with a positively driven normally closed contact must be used for the shown S1 switch per EN 60947-5-1. A 2-pole category 3 or 4 / SIL 3 / PL e switching device must be used for the shown K1 relay.

The information in the user documentation for the switching devices must be observed!

The following fault events (per [List of possible fault events](#)) must be evaluated with regard to the safety-critical influence on switching device K1 or must be able to be excluded by suitable wiring measures (short-circuit-proof wiring).

- Fault event 8
- Fault event 9
- Fault event 14
- Fault event 15

### 7.2.1.4.2 STO, category 3 / SIL 3 / PL e (variant B)

The enable input of the 8D1 module is supplied via a safe digital output (Out1+, Out1-). If the safety function is requested, then the safe digital output cuts off the enable input.

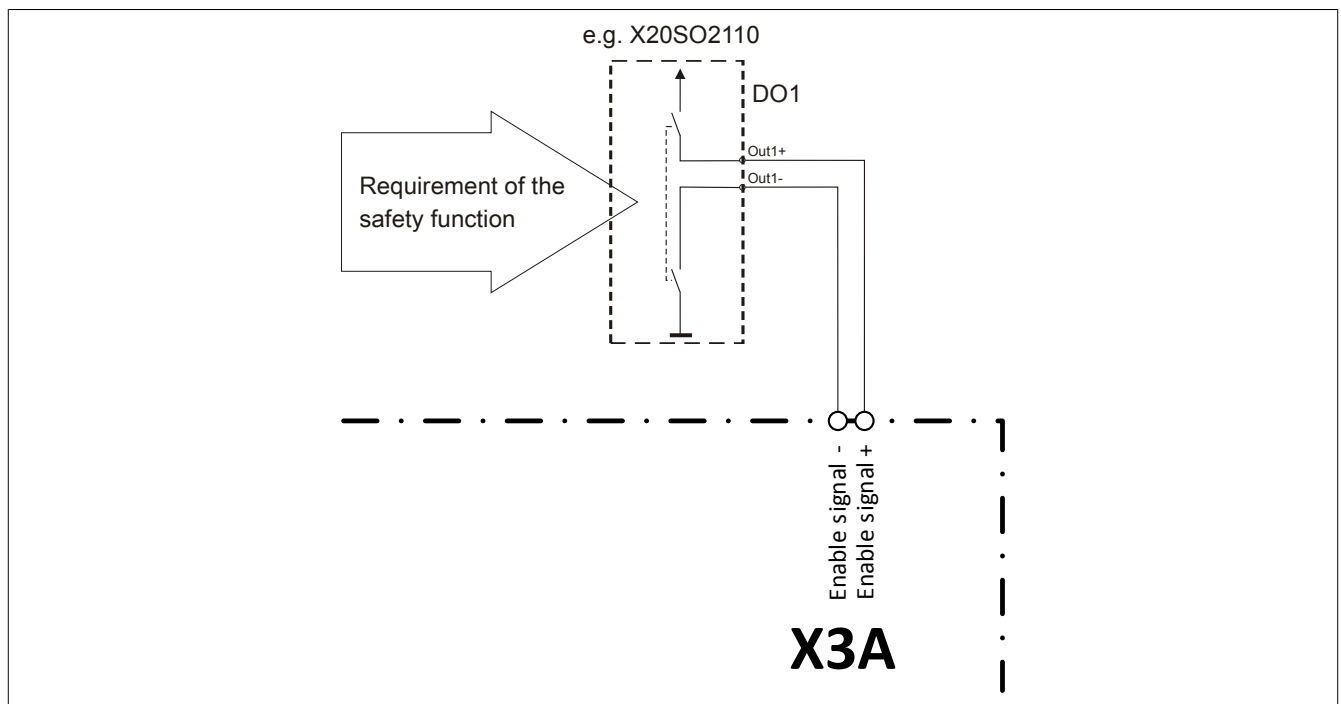

Figure 102: STO, category 3 / SIL 3 / PL e (variant B)

<sup>15)</sup> The numbers for the connections refer to "STO, category 3 / SIL 3 / PL e (variant A)".

The consideration of fault events in the external wiring for fault exclusion purposes is not necessary since faults are detected by the safe digital output.

For additional information about the use, compatibility and wiring of safe output modules, see the "Integrated safety technology user's manual".

The most current version of the "Integrated safety technology user's manual" is available for download on the B&R website ([www.br-automation.com](http://www.br-automation.com))!

## **Danger!**

**A safe category 3 or 4 / SIL 3 / PL e digital output module must be used for the shown DO1 safe digital output.**

**The information in the user documentation for the safe digital output module must be observed!**

### 7.2.1.5 Wiring the enable inputs per required safety category / SIL / PL and functionality (STO, SS1, SS2, SLS, SOS)

The following illustrates exemplary circuit suggestions for the external wiring of the enable input of the 8D1 module. They vary in their safety classification per EN 60204-1, ISO 13849 and EN 61800-5-2 as well as with regard to the safety function (STO, SS1, SS2, SLS, SOS).

#### Information:

The following wiring suggestions do not include a line contactor since one is not necessary to comply with the required safety category / SIL / PL.

#### 7.2.1.5.1 STO, SLS, SOS - Safety category 3 / SIL 3 / PL e

#### 8D1

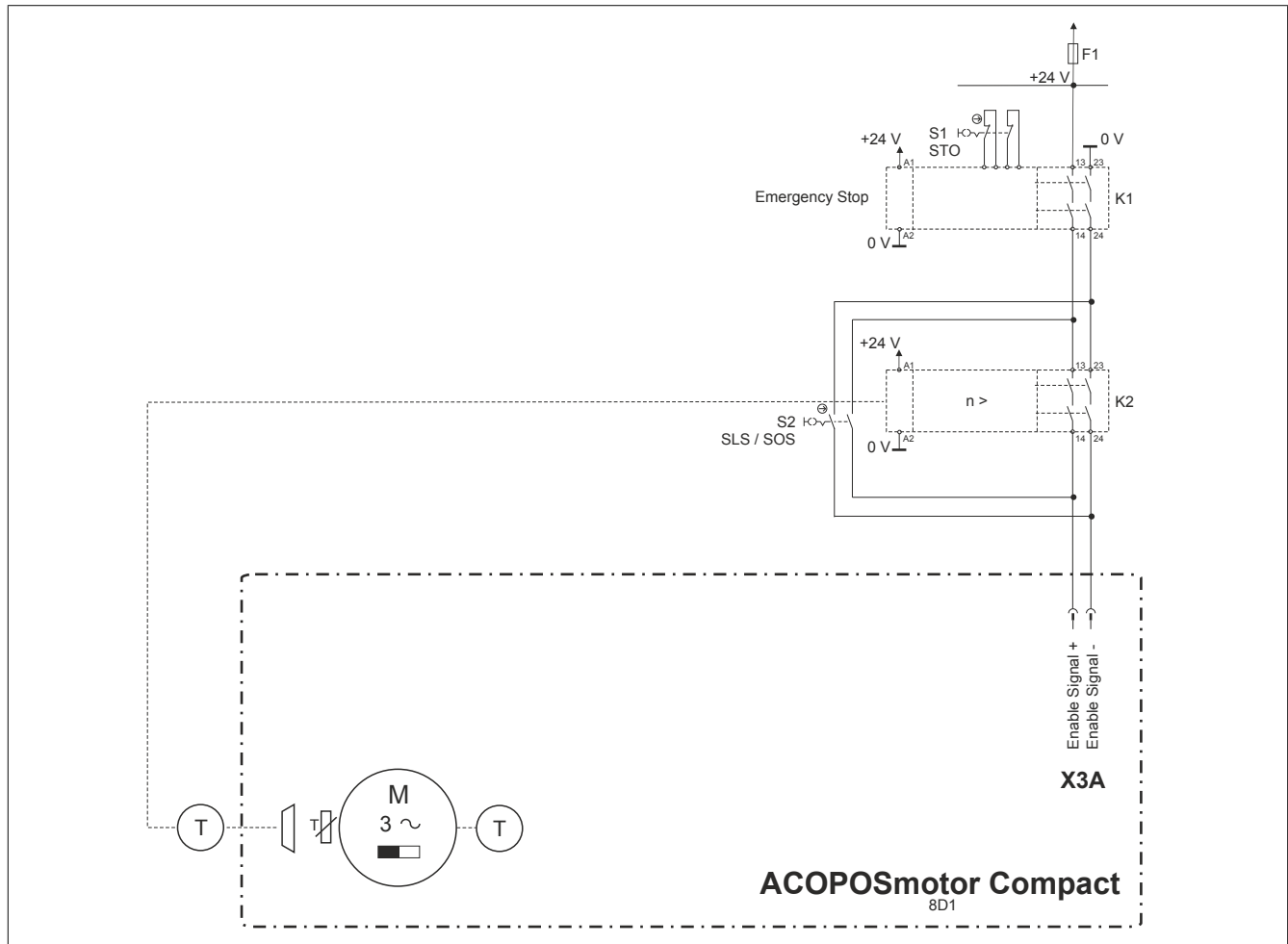

Figure 103: STO, SLS, SOS - Safety category 3 / SIL 3 / PL e

#### Danger!

The brake shown in this figure as well as the brake controller provided by the ACOPOSmotor Compact module (8D1) are not part of the safety function!

#### Information:

The module-internal encoder of the ACOPOSmotor Compact module (8D1) does not have certification for safe position evaluation and is therefore not suitable for implementing this safety function.

#### STO

Activating emergency switch-off S1 de-energizes the switching contacts of emergency switching-off device K1. This cuts off the enable input of the 8D1 module. The supply of power to the motor is cut off as a result.

This ensures that the supply of power to the motor is cut off immediately in every case.

**SLS**

Safety function SLS is activated by opening switch S2. The switching contacts of overspeed monitor K2 are opened if the monitor's set speed limit is exceeded. This cuts off the enable input of the 8D1 module. The supply of power to the motor is cut off as a result.

This ensures that the supply of power to the motor is cut off immediately in every case when the speed limit set on overspeed monitor K2 is exceeded.

**SOS**

Safety function SOS is activated by opening switch S2. The switching contacts of standstill monitor K2 are opened when the standstill monitor is activated. This cuts off the enable input of the 8D1 module. The supply of power to the motor is cut off as a result.

This ensures that the supply of power to the motor is cut off immediately in every case if standstill monitor K2 is activated.

**Information:**

Safety function SLS or SOS can be implemented depending on the function of switching device K2 (overspeed monitor or standstill monitor).

**Danger!**

2-pole category 3 or 4 / SIL 3 / PL e switching devices with a positively driven normally closed contact must be used for the shown S1 and S2 switches per EN 60947-5-1. 2-pole category 3 or 4 / SIL 3 / PL e switching devices must be used for the shown K1 and K2 relays.

The information in the user documentation for the switching devices must be observed!

## 7.2.1.5.2 SS1, SLS, SS2 - Safety category 3 / SIL 3 / PL e (variant A)

## 8D1 with electronics option

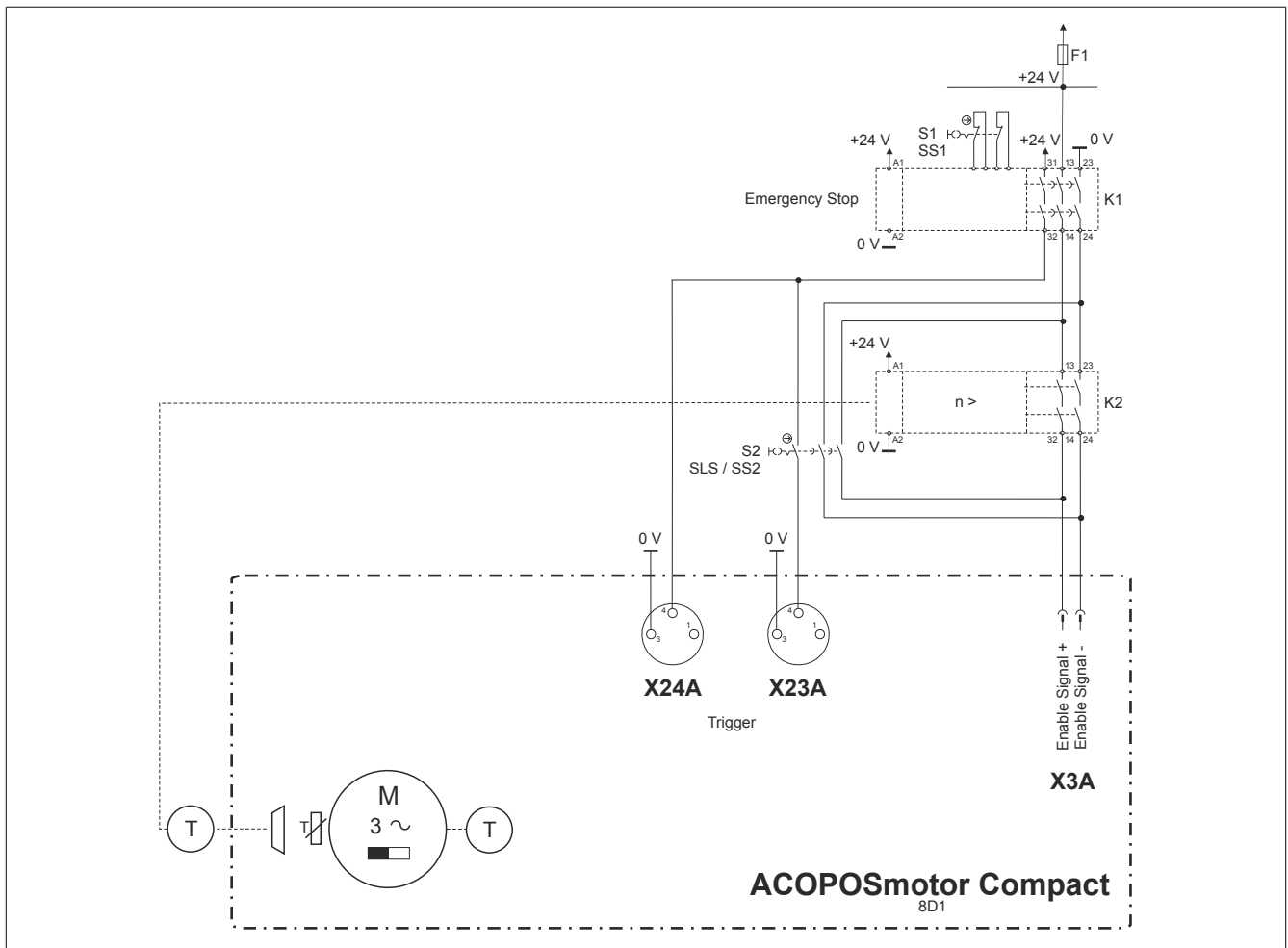

Figure 104: SS1, SLS, SS2 - Safety category 3 / SIL 3 / PL e (variant A)

**Danger!**

The brake shown in this figure as well as the brake controller provided by the ACOPOSmotor Compact module (8D1) are not part of the safety function!

**Information:**

The module-internal encoder of the ACOPOSmotor Compact module (8D1) does not have certification for safe position evaluation and is therefore not suitable for implementing this safety function.

**Information:**

With this wiring, input X24A / Trigger of the 8D1 module must be configured as quick stop for the respective axis.

**SS1**

Activating emergency switch-off S1 triggers an active braking procedure via an undelayed switching contact of emergency switching-off device K1 on input X24A / Trigger of the 8D1 module. After a defined amount of time, the delayed switching contacts of emergency switching-off device K1 are de-energized. This cuts off the enable input of the 8D1 module. The supply of power to the motor is cut off as a result.

This ensures that the supply of power to the motor is cut off in every case after a defined amount of time.

**SLS**

Opening switch S2 activates safety function SLS and triggers an active braking procedure on input X23A / Trigger of the 8D1 module. After a defined amount of time, speed monitoring is activated on overspeed monitor K2. If the configured speed limit is exceeded, the enable input of the 8D1 module is cut off via the undelayed switching contacts of overspeed monitor K2. The supply of power to the motor is cut off as a result.

This ensures that the supply of power to the motor is cut off immediately in every case when the speed limit set on overspeed monitor K2 is exceeded.

**SS2**

Opening switch S2 activates safety function SS2 and triggers an active braking procedure on input X23A / Trigger of the 8D1 module. After a defined amount of time, standstill monitoring is activated on standstill monitor K2. If the configured tolerance limit is exceeded (standstill monitor K2 is activated), the enable input of the 8D1 module is cut off via the undelayed switching contacts of standstill monitor K2. The supply of power to the motor is cut off as a result.

This ensures that the supply of power to the motor is cut off immediately in every case if standstill monitor K2 is activated.

**Information:**

**Safety function SLS or SS2 can be implemented depending on the function of switching device K2 (overspeed monitor or standstill monitor).**

**Danger!**

**2-pole category 3 or 4 / SIL 3 / PL e switching devices with a positively driven normally closed contact must be used for the shown S1 and S2 switches per EN 60947-5-1. 2-pole category 3 or 4 / SIL 3 / PL e switching devices must be used for the shown K1 and K2 relays.**

**The information in the user documentation for the switching devices must be observed!**

## 7.2.1.5.3 SS1, SLS, SS2 - Safety category 3 / SIL 3 / PL e (variant B)

## 8D1

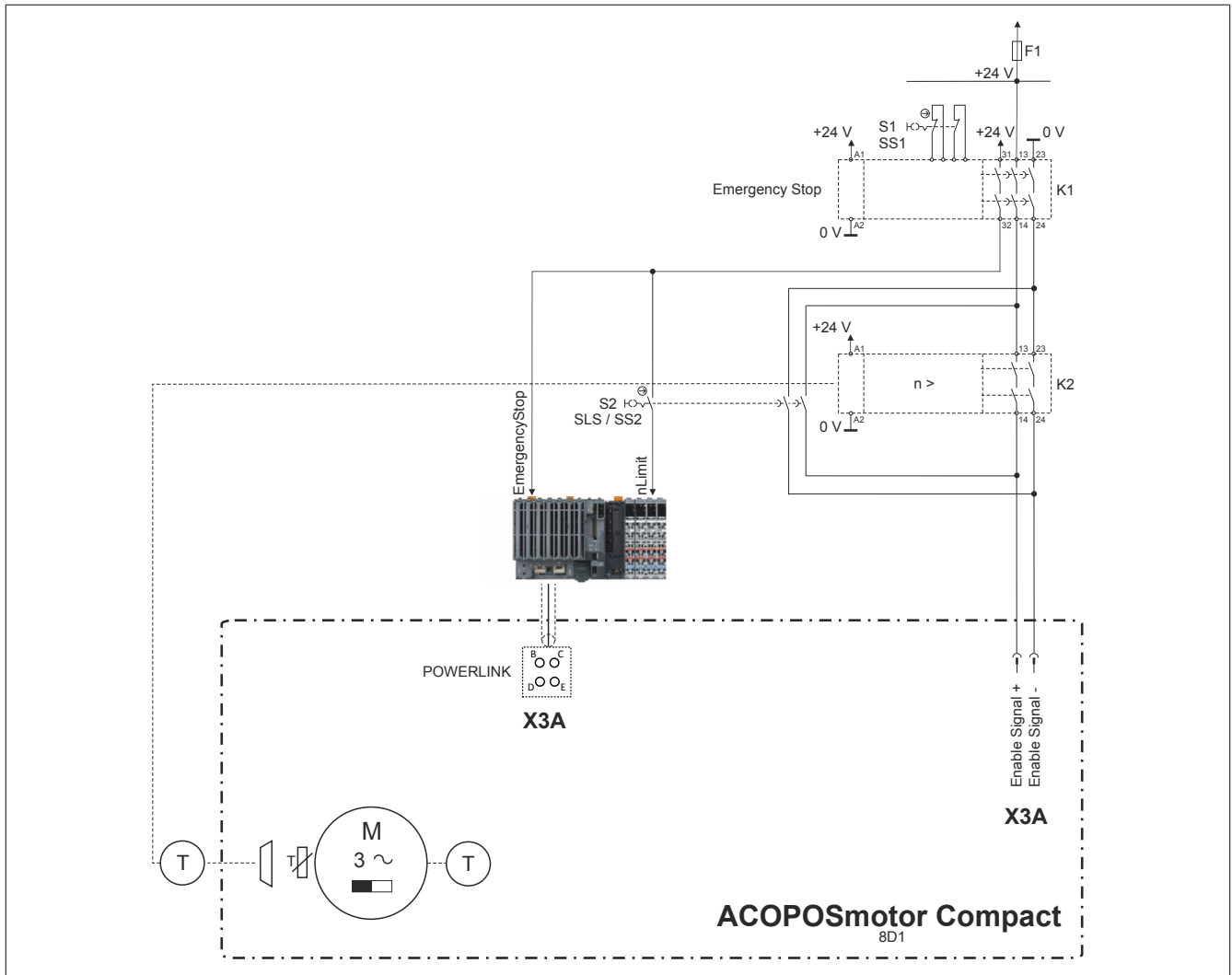

Figure 105: SS1, SLS, SS2 - Safety category 3 / SIL 3 / PL e (variant B)

**Danger!**

The brake shown in this figure as well as the brake controller provided by the ACOPOSmotor Compact module (8D1) are not part of the safety function!

**Information:**

The module-internal encoder of the ACOPOSmotor Compact module (8D1) does not have certification for safe position evaluation and is therefore not suitable for implementing this safety function.

**SS1**

Activating emergency switch-off S1 triggers an active braking procedure over the POWERLINK network via an undelayed switching contact of emergency switching-off device K1 on digital input "EmergencyStop" on the controller (see "Example code" on page 349). After a defined amount of time, the delayed switching contacts of emergency switching-off device K1 are de-energized. This cuts off the enable input of the 8D1 module. The supply of power to the motor is cut off as a result.

This ensures that the supply of power to the motor is cut off in every case after a defined amount of time.

## SLS

Opening switch S2 activates safety function SLS and triggers active braking via the POWERLINK network on digital input "nLimit" on the controller (see "Example code" on page 349). After a defined amount of time, speed monitoring is activated on overspeed monitor K2. If the configured speed limit is exceeded, the enable input of the 8D1 module is cut off via the undelayed switching contacts of overspeed monitor K2. The supply of power to the motor is cut off as a result.

This ensures that the supply of power to the motor is cut off immediately in every case when the speed limit set on overspeed monitor K2 is exceeded.

## SS2

Opening switch S2 activates safety function SS2 and triggers an active braking procedure via the POWERLINK network on digital input "nLimit" on the controller (see "Example code" on page 349). After a defined amount of time, standstill monitoring is activated on standstill monitor K2. If the configured tolerance limit is exceeded (standstill monitor K2 is activated), the enable input of the 8D1 module is cut off via the undelayed switching contacts of standstill monitor K2. The supply of power to the motor is cut off as a result.

This ensures that the supply of power to the motor is cut off immediately in every case if standstill monitor K2 is activated.

### Information:

Safety function SLS or SS2 can be implemented depending on the function of switching device K2 (overspeed monitor or standstill monitor).

### Danger!

2-pole category 3 or 4 / SIL 3 / PL e switching devices with a positively driven normally closed contact must be used for the shown S1 and S2 switches per EN 60947-5-1. 2-pole category 3 or 4 / SIL 3 / PL e switching devices must be used for the shown K1 and K2 relays.

The information in the user documentation for the switching devices must be observed!

## Example code

Issuing the stop command via POWERLINK:

```

if ( ! statStopActive )
{
    /* Move stop not active: check move stop inputs */
    if ( DI_EmergencyStop == INPUT_LEVEL_LOW )
    {
        /* Move stop with emergency stop deceleration */
        MC_Stop_0.Deceleration = E_STOP_DECELERATION;
        MC_Stop_0.Execute = 1;
        statStopActive = 1;
    }
    else if ( cmdStopAxis1 )
    {
        /* Move stop with application deceleration */
        MC_Stop_0.Deceleration = APPLICATION_DECELERATION;
        MC_Stop_0.Execute = 1;
        statStopActive = 1;
    }
}
else
{
    /* Move stop is active, wait until it is finished */
    if ( DI_EmergencyStop == INPUT_LEVEL_HIGH &&
        cmdStopAxis1 == 0 &&
        MC_Stop_0.Done == 1 )
    {
        /* Move stop complete */
        MC_Stop_0.Execute = 0;
        statStopActive = 0;
    }
}
...
MC_Stop_0.Axis = AxisRef1;
MC_Stop( &MC_Stop_0 );
...

```

## 7.2.1.5.4 STO, SLS, SOS - Safety category 3 / SIL 2 / PL d

## 8D1

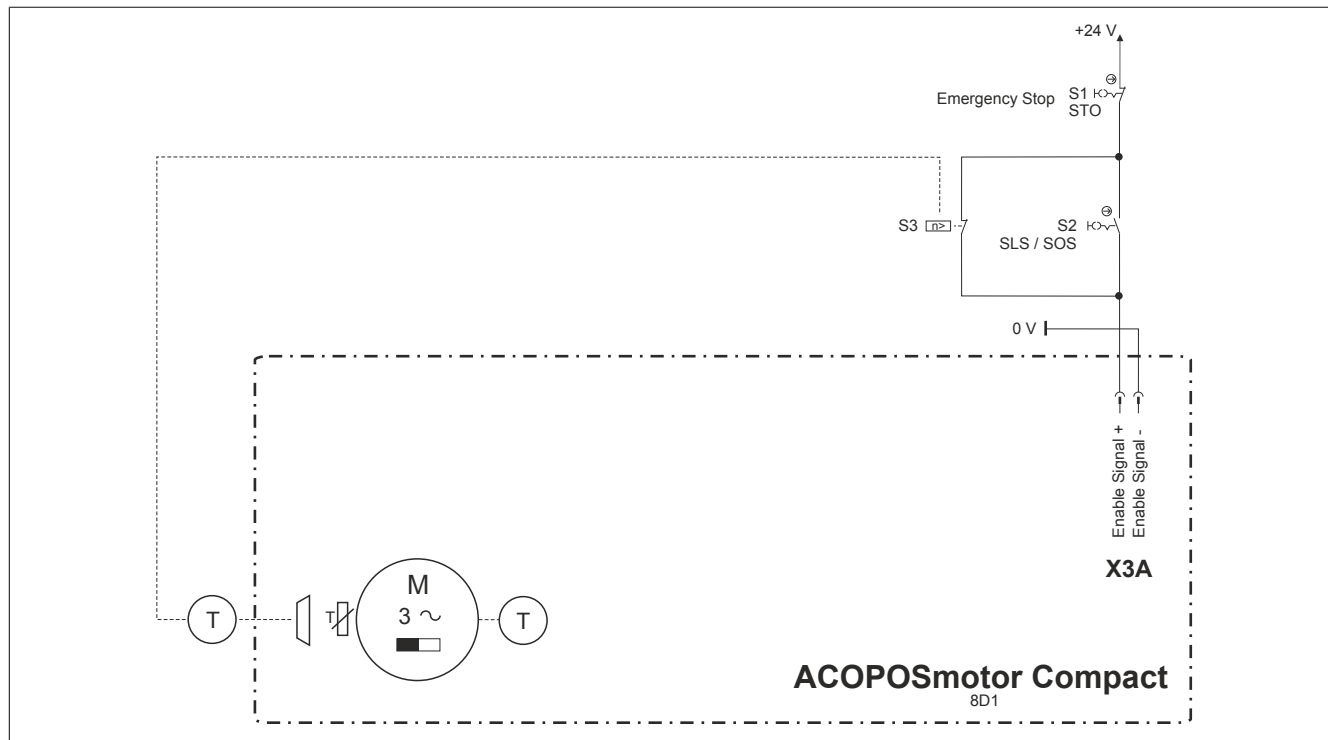

Figure 106: STO, SLS, SOS - Safety category 3 / SIL 2 / PL d

**Danger!**

The brake shown in this figure as well as the brake controller provided by the ACOPOSmotor Compact module (8D1) are not part of the safety function!

**Information:**

The module-internal encoder of the ACOPOSmotor Compact module (8D1) does not have certification for safe position evaluation and is therefore not suitable for implementing this safety function.

**STO**

The enable input of the 8D1 module is cut off by activating emergency switch-off S1. The supply of power to the motor is cut off as a result.

This ensures that the supply of power to the motor is cut off immediately in every case.

**SLS**

Safety function SLS is activated by opening switch S2. The switching contact of overspeed monitor S3 is opened if the monitor's configured speed limit is exceeded. The enable input of the 8D1 module is cut off. The supply of power to the motor is cut off as a result.

This ensures that the supply of power to the motor is cut off immediately in every case when the speed limit set on overspeed monitor S3 is exceeded.

**SOS**

Safety function SOS is activated by opening switch S2. If standstill monitor S3 is activated, then the switching contact of the overspeed monitor is opened. This cuts off the enable input of the 8D1 module. The supply of power to the motor is cut off as a result.

This ensures that the supply of power to the motor is cut off immediately in every case if standstill monitor S3 is activated.

**Information:**

Safety function SLS or SOS can be implemented depending on the function of switching device S3 (overspeed monitor or standstill monitor).

**Danger!**

1-pole category 3 / SIL 2 / PL d switching devices with a positively driven normally closed contact must be used for the shown S1 and S2 switches per EN 60947-5-1. A 1-pole category 3 / SIL 2 / PL d switching device must be used for the shown S3 switching device.

The information in the user documentation for the switching device must be observed!

## 7.2.1.5.5 SS1, SLS, SS2 - Safety category 3 / SIL 2 / PL d (variant A)

## 8D1 with electronics option

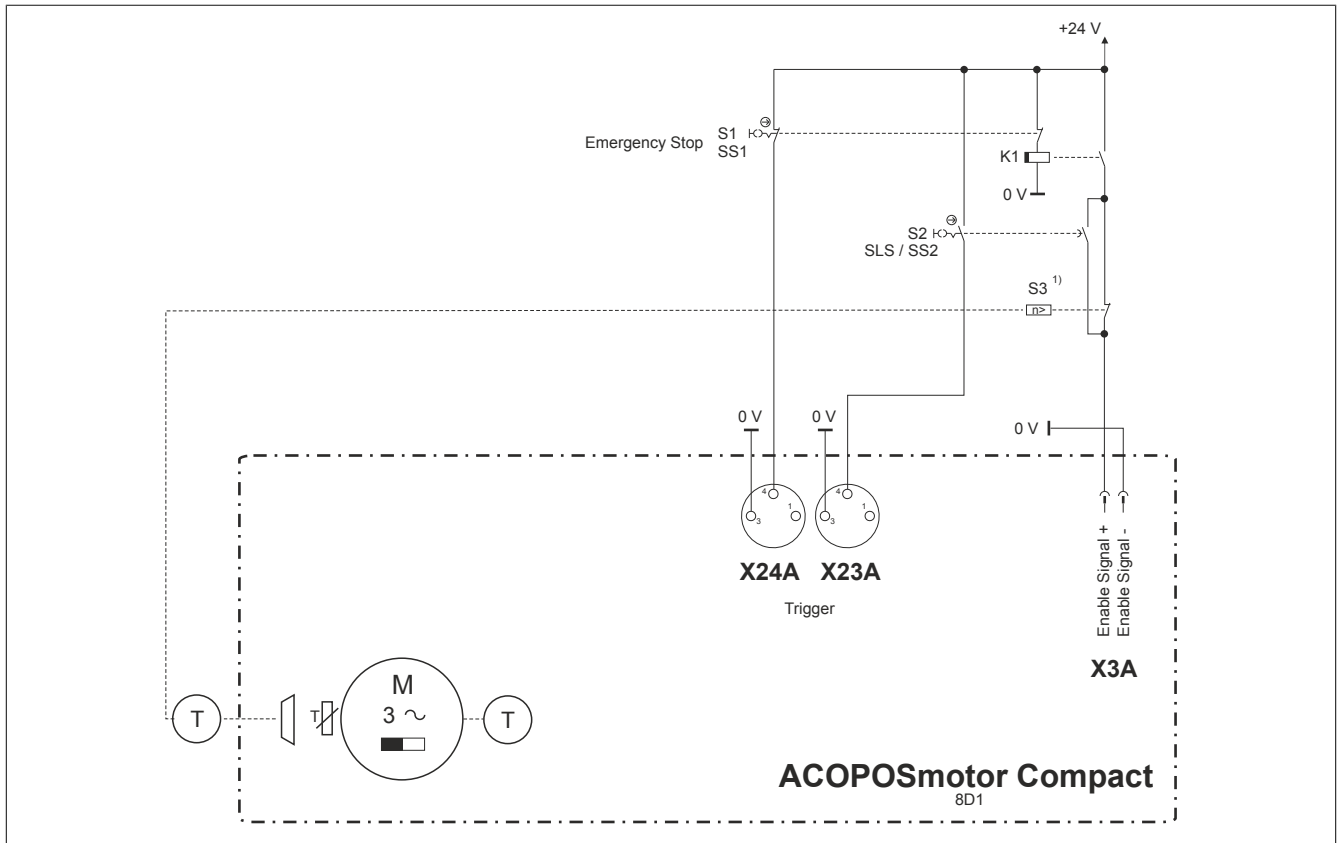

Figure 107: SS1, SLS, SS2 - Safety category 3 / SIL 2 / PL d (variant A)

**Danger!**

The brake shown in this figure as well as the brake controller provided by the ACOPOSmotor Compact module (8D1) are not part of the safety function!

**Information:**

The module-internal encoder of the ACOPOSmotor Compact module (8D1) does not have certification for safe position evaluation and is therefore not suitable for implementing this safety function.

**Information:**

With this wiring, input X24A / Trigger of the 8D1 module must be configured as quick stop for the respective axis.

**SS1**

Activating emergency switch-off S1 causes relay K1 to drop out. This triggers an active braking procedure via input X24A / Trigger of the 8D1 module.

After a defined amount of time, auxiliary dropout delay relay K1 is de-energized. This cuts off the enable input of the 8D1 module. The supply of power to the motor is cut off as a result.

This ensures that the supply of power to the motor is cut off in every case after a defined amount of time.

**SLS**

Opening switch S2 activates safety function SLS and triggers an active braking procedure via input X23A / Trigger of the 8D1 module. After a defined amount of time, speed monitoring is activated on overspeed monitor S3. If the configured speed limit is exceeded, the enable input of the 8D1 module is cut off via the undelayed switching contact of overspeed monitor S3. The supply of power to the motor is cut off as a result.

This ensures that the supply of power to the motor is cut off immediately in every case when the speed limit set on overspeed monitor S3 is exceeded.

**SS2**

Opening switch S2 activates safety function SS2 and triggers an active braking procedure via input X23A / Trigger of the 8D1 module. After a defined amount of time, standstill monitoring is activated on standstill monitor S3. If the configured tolerance limit is exceeded (standstill monitor S3 is activated), the enable input of the 8D1 module is cut off via the undelayed switching contact of standstill monitor S3. The supply of power to the motor is cut off as a result.

This ensures that the supply of power to the motor is cut off immediately in every case if standstill monitor S3 is activated.

**Information:**

**Safety function SLS or SS2 can be implemented depending on the function of switching device S3 (overspeed monitor or standstill monitor).**

**Danger!**

**1-pole category 3 / SIL 2 / PL d switching devices with a positively driven normally closed contact must be used for the shown S1 and S2 switches per EN 60947-5-1. 1-pole category 3 / SIL 2 / PL d switching devices must be used for the shown K1 relay and switching device S3.**

**The information in the user documentation for the switching devices must be observed!**

## 7.2.1.5.6 SS1, SLS, SS2 - Safety category 3 / SIL 2 / PL d (variant B)

## 8D1

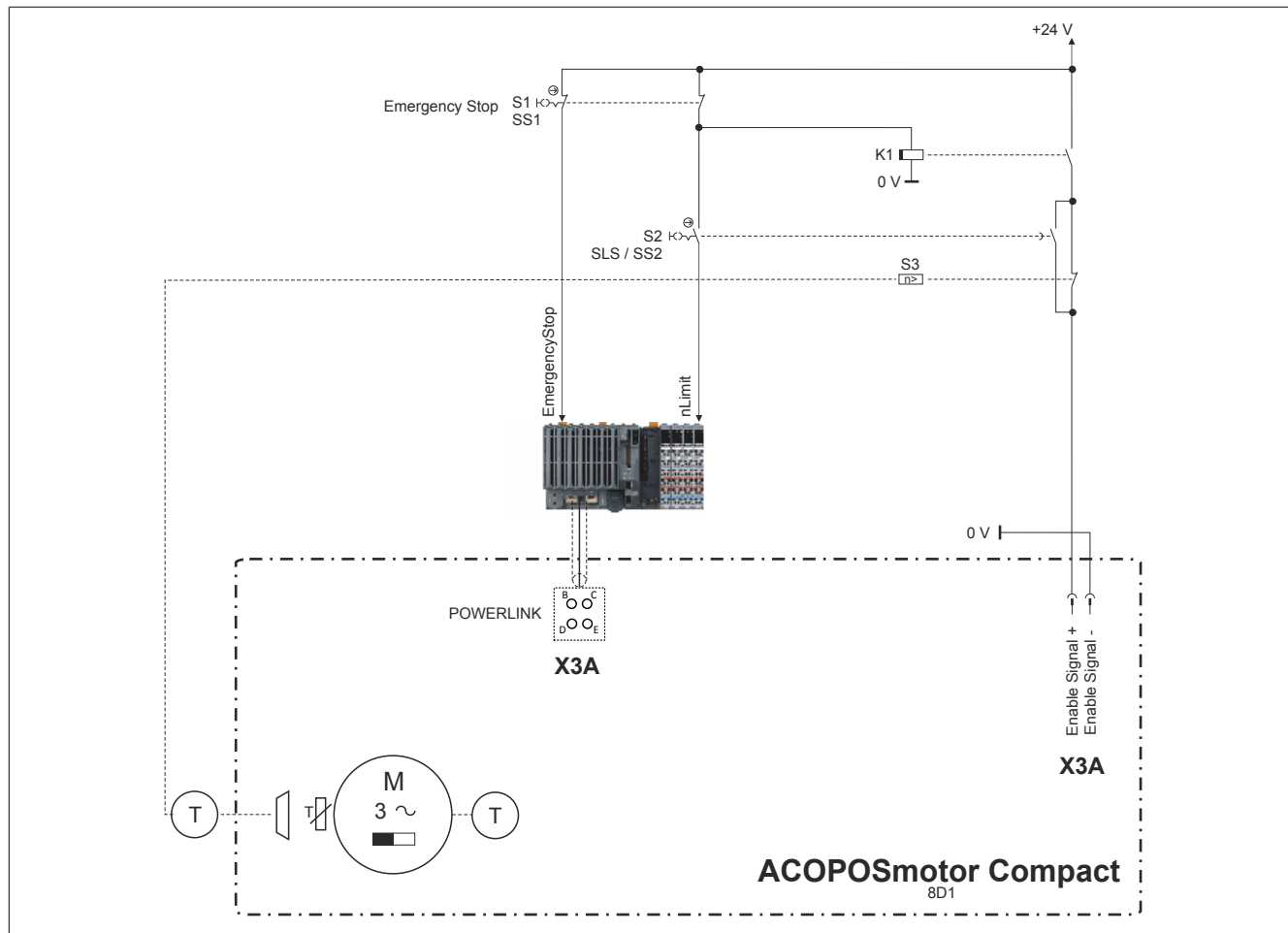

Figure 108: SS1, SLS, SS2 - Safety category 3 / SIL 2 / PL d (variant B)

**Danger!**

The brake shown in this figure as well as the brake controller provided by the ACOPOSmotor Compact module (8D1) are not part of the safety function!

**Information:**

The module-internal encoder of the ACOPOSmotor Compact module (8D1) does not have certification for safe position evaluation and is therefore not suitable for implementing this safety function.

**SS1**

Activating emergency switch-off S1 triggers an active braking procedure via digital input "EmergencyStop" on the controller (see "Example code" on page 349).

After a defined amount of time, auxiliary dropout delay relay K1 is de-energized. This cuts off the enable input of the 8D1 module. The supply of power to the motor is cut off as a result.

This ensures that the supply of power to the motor is cut off in every case after a defined amount of time.

**SLS**

Opening switch S2 activates safety function SLS and triggers an active braking procedure via digital input "nLimit" on the controller (see "Example code" on page 349). After a defined amount of time, speed monitoring is activated on overspeed monitor S3. If the configured speed limit is exceeded, the enable input of the 8D1 module is cut off via the undelayed switching contact of overspeed monitor S3. The supply of power to the motor is cut off as a result.

This ensures that the supply of power to the motor is cut off immediately in every case when the speed limit set on overspeed monitor S3 is exceeded.

## SS2

Opening switch S2 activates safety function SS2 and triggers an active braking procedure via digital input "nLimit" on the controller (see "Example code" on page 349). After a defined amount of time, standstill monitoring is activated on standstill monitor S3. If the configured tolerance limit is exceeded (standstill monitor S3 is activated), the enable input of the 8D1 module is cut off via the undelayed switching contact of standstill monitor S3. The supply of power to the motor is cut off as a result.

This ensures that the supply of power to the motor is cut off immediately in every case if standstill monitor S3 is activated.

Safety function SLS or SS2 can be implemented depending on the function of switching device S3 (overspeed monitor or standstill monitor).

### **Danger!**

**2-pole or 1-pole category 3 / SIL 2 / PL d switching devices with a positively driven normally closed contact must be used for the shown S1 and S2 switches per EN 60947-5-1. 1-pole category 3 / SIL 2 / PL d switching devices must be used for the shown K1 relay and switching device S3.**

**The information in the user documentation for the switching devices must be observed!**

## 8 Accessories

### 8.1 ACOPOSremote / 8CVE connection box / ACOPOSmotor

#### 8.1.1 General accessories

##### 8.1.1.1 Overview

##### Connection cables

Order number	Short description	Page
8CCH0005.11120-1	Hybrid cable for connecting 8BVE to 8CVI or 8DI, length 5 m, 2x 2x 0.34 mm <sup>2</sup> + 4x 0.75 mm <sup>2</sup> + 5x 2.5 mm <sup>2</sup> , 1x 15-pin female TYCO connector, 1x RJ45 connector, integrated shield fixing, can be used in cable drag chains	357
8CCH0007.11120-1	Hybrid cable for connecting 8BVE to 8CVI or 8DI, length 7 m, 2x 2x 0.34 mm <sup>2</sup> + 4x 0.75 mm <sup>2</sup> + 5x 2.5 mm <sup>2</sup> , 1x 15-pin female TYCO connector, 1x RJ45 connector, integrated shield fixing, can be used in cable drag chains	357
8CCH0010.11120-1	Hybrid cable for connecting 8BVE to 8CVI or 8DI, length 10 m, 2x 2x 0.34 mm <sup>2</sup> + 4x 0.75 mm <sup>2</sup> + 5x 2.5 mm <sup>2</sup> , 1x 15-pin female TYCO connector, 1x RJ45 connector, integrated shield fixing, can be used in cable drag chains	357
8CCH0015.11120-1	Hybrid cable for connecting 8BVE to 8CVI or 8DI, length 15 m, 2x 2x 0.34 mm <sup>2</sup> + 4x 0.75 mm <sup>2</sup> + 5x 2.5 mm <sup>2</sup> , 1x 15-pin female TYCO connector, 1x RJ45 connector, integrated shield fixing, can be used in cable drag chains	357
8CCH0020.11120-1	Hybrid cable for connecting 8BVE to 8CVI or 8DI, length 20 m, 2x 2x 0.34 mm <sup>2</sup> + 4x 0.75 mm <sup>2</sup> + 5x 2.5 mm <sup>2</sup> , 1x 15-pin female TYCO connector, 1x RJ45 connector, integrated shield fixing, can be used in cable drag chains	357
8CCH0025.11120-1	Hybrid cable for connecting 8BVE to 8CVI or 8DI, length 25 m, 2x 2x 0.34 mm <sup>2</sup> + 4x 0.75 mm <sup>2</sup> + 5x 2.5 mm <sup>2</sup> , 1x 15-pin female TYCO connector, 1x RJ45 connector, integrated shield fixing, can be used in cable drag chains	357

##### Hybrid cables

Order number	Short description	Page
8CCH0005.11110-1	Hybrid cable, length 5 m, 2x 2x 0.34 mm <sup>2</sup> + 4x 0.75 mm <sup>2</sup> + 5x 2.5 mm <sup>2</sup> , 2x 15-pin female TYCO connector, can be used in cable drag chains	362
8CCH0007.11110-1	Hybrid cable, length 7 m, 2x 2x 0.34 mm <sup>2</sup> + 4x 0.75 mm <sup>2</sup> + 5x 2.5 mm <sup>2</sup> , 2x 15-pin female TYCO connector, can be used in cable drag chains	362
8CCH0010.11110-1	Hybrid cable, length 10 m, 2x 2x 0.34 mm <sup>2</sup> + 4x 0.75 mm <sup>2</sup> + 5x 2.5 mm <sup>2</sup> , 2x 15-pin female TYCO connector, can be used in cable drag chains	362
8CCH0015.11110-1	Hybrid cable, length 15 m, 2x 2x 0.34 mm <sup>2</sup> + 4x 0.75 mm <sup>2</sup> + 5x 2.5 mm <sup>2</sup> , 2x 15-pin female TYCO connector, can be used in cable drag chains	362
8CCH0020.11110-1	Hybrid cable, length 20 m, 2x 2x 0.34 mm <sup>2</sup> + 4x 0.75 mm <sup>2</sup> + 5x 2.5 mm <sup>2</sup> , 2x 15-pin female TYCO connector, can be used in cable drag chains	362

Order number	Short description	Page
8CCH0001.11130-1	Hybrid cable, length 1 m, 2x 2x 0.34 mm <sup>2</sup> + 4x 0.75 mm <sup>2</sup> + 5x 2.5 mm <sup>2</sup> , 2x 15-pin female TYCO connector, 1x connector insert rotated 180°, can be used in cable drag chains	364
8CCH0002.11130-1	Hybrid cable, length 2 m, 2x 2x 0.34 mm <sup>2</sup> + 4x 0.75 mm <sup>2</sup> + 5x 2.5 mm <sup>2</sup> , 2x 15-pin female TYCO connector, 1x connector insert rotated 180°, can be used in cable drag chains	364
8CCH0003.11130-1	Hybrid cable, length 3 m, 2x 2x 0.34 mm <sup>2</sup> + 4x 0.75 mm <sup>2</sup> + 5x 2.5 mm <sup>2</sup> , 2x 15-pin female TYCO connector, 1x connector insert rotated 180°, can be used in cable drag chains	364
8CCH0004.11130-1	Hybrid cable, length 4 m, 2x 2x 0.34 mm <sup>2</sup> + 4x 0.75 mm <sup>2</sup> + 5x 2.5 mm <sup>2</sup> , 2x 15-pin female TYCO connector, 1x connector insert rotated 180°, can be used in cable drag chains	364
8CCH0005.11130-1	Hybrid cable, length 5 m, 2x 2x 0.34 mm <sup>2</sup> + 4x 0.75 mm <sup>2</sup> + 5x 2.5 mm <sup>2</sup> , 2x 15-pin female TYCO connector, 1x connector insert rotated 180°, can be used in cable drag chains	364

Order number	Short description	Page
8CCH0001.11230-1	Hybrid cable, length 1 m, 2x 2x 0.34 mm <sup>2</sup> + 4x 0.75 mm <sup>2</sup> + 5x 2.5 mm <sup>2</sup> , 2x 15-pin female TYCO connector, connector insert rotated 180°, can be used in cable drag chains	367
8CCH0002.11230-1	Hybrid cable, length 2 m, 2x 2x 0.34 mm <sup>2</sup> + 4x 0.75 mm <sup>2</sup> + 5x 2.5 mm <sup>2</sup> , 2x 15-pin female TYCO connector, connector insert rotated 180°, can be used in cable drag chains	367
8CCH0003.11230-1	Hybrid cable, length 3 m, 2x 2x 0.34 mm <sup>2</sup> + 4x 0.75 mm <sup>2</sup> + 5x 2.5 mm <sup>2</sup> , 2x 15-pin female TYCO connector, connector insert rotated 180°, can be used in cable drag chains	367
8CCH0004.11230-1	Hybrid cable, length 4 m, 2x 2x 0.34 mm <sup>2</sup> + 4x 0.75 mm <sup>2</sup> + 5x 2.5 mm <sup>2</sup> , 2x 15-pin female TYCO connector, connector insert rotated 180°, can be used in cable drag chains	367
8CCH0005.11230-1	Hybrid cable, length 5 m, 2x 2x 0.34 mm <sup>2</sup> + 4x 0.75 mm <sup>2</sup> + 5x 2.5 mm <sup>2</sup> , 2x 15-pin female TYCO connector, connector insert rotated 180°, can be used in cable drag chains	367

Order number	Short description	Page
8CCH0005.11220-1	Hybrid cable for connecting 8BVE to 8CVI or 8DI, length 5 m, 2x 2x 0.34 mm <sup>2</sup> + 4x 0.75 mm <sup>2</sup> + 5x 2.5 mm <sup>2</sup> , 1x 15-pin female TYCO connector, connector insert rotated 180°, can be used in cable drag chains	370
8CCH0007.11220-1	Hybrid cable for connecting 8BVE to 8CVI or 8DI, length 7 m, 2x 2x 0.34 mm <sup>2</sup> + 4x 0.75 mm <sup>2</sup> + 5x 2.5 mm <sup>2</sup> , 1x 15-pin female TYCO connector, connector insert rotated 180°, can be used in cable drag chains	370
8CCH0010.11220-1	Hybrid cable for connecting 8BVE to 8CVI or 8DI, length 10 m, 2x 2x 0.34 mm <sup>2</sup> + 4x 0.75 mm <sup>2</sup> + 5x 2.5 mm <sup>2</sup> , 1x 15-pin female TYCO connector, connector insert rotated 180°, can be used in cable drag chains	370
8CCH0015.11220-1	Hybrid cable for connecting 8BVE to 8CVI or 8DI, length 15 m, 2x 2x 0.34 mm <sup>2</sup> + 4x 0.75 mm <sup>2</sup> + 5x 2.5 mm <sup>2</sup> , 1x 15-pin female TYCO connector, connector insert rotated 180°, can be used in cable drag chains	370
8CCH0020.11220-1	Hybrid cable for connecting 8BVE to 8CVI or 8DI, length 20 m, 2x 2x 0.34 mm <sup>2</sup> + 4x 0.75 mm <sup>2</sup> + 5x 2.5 mm <sup>2</sup> , 1x 15-pin female TYCO connector, connector insert rotated 180°, can be used in cable drag chains	370

## Fan kits

Order number	Short description	Page
8ZDFB4000000.000-0	ACOPOSmotor fan kit for 8DI4xx modules	374
8ZDFB5000000.000-0	ACOPOSmotor fan kit for 8DI5xx modules	375

## Slot covers / Threaded caps

Order number	Short description	Page
8CXC000.0000-00	Accessory set: 1x slot cover for hybrid connector	377
X67AC0M08	X67 M8 threaded caps, 50 pcs.	378
X67AC0M12	X67 M12 threaded caps, 50 pcs.	378

### 8.1.1.2 Cables

#### 8.1.1.2.1 Connection cables

##### 8.1.1.2.1.1 General information

- Can be used in cable drag chains
- Cable for connection of ACOPOSremote / ACOPOSmotor drive systems to ACOPOSmulti 8BVE expansion modules
- Hybrid connector system for secure connections
- Integrated shield plate

##### 8.1.1.2.1.2 Order data

Order number	Short description	Figure
	<b>8BVE / 8CVI connection cables</b>	
8CCH0005.11120-1	Hybrid cable for connecting 8BVE to 8CVI or 8DI, length 5 m, 2x 2x 0.34 mm <sup>2</sup> + 4x 0.75 mm <sup>2</sup> + 5x 2.5 mm <sup>2</sup> , 1x 15-pin female TYCO connector, 1x RJ45 connector, integrated shield fixing, can be used in cable drag chains	
8CCH0007.11120-1	Hybrid cable for connecting 8BVE to 8CVI or 8DI, length 7 m, 2x 2x 0.34 mm <sup>2</sup> + 4x 0.75 mm <sup>2</sup> + 5x 2.5 mm <sup>2</sup> , 1x 15-pin female TYCO connector, 1x RJ45 connector, integrated shield fixing, can be used in cable drag chains	
8CCH0010.11120-1	Hybrid cable for connecting 8BVE to 8CVI or 8DI, length 10 m, 2x 2x 0.34 mm <sup>2</sup> + 4x 0.75 mm <sup>2</sup> + 5x 2.5 mm <sup>2</sup> , 1x 15-pin female TYCO connector, 1x RJ45 connector, integrated shield fixing, can be used in cable drag chains	
8CCH0015.11120-1	Hybrid cable for connecting 8BVE to 8CVI or 8DI, length 15 m, 2x 2x 0.34 mm <sup>2</sup> + 4x 0.75 mm <sup>2</sup> + 5x 2.5 mm <sup>2</sup> , 1x 15-pin female TYCO connector, 1x RJ45 connector, integrated shield fixing, can be used in cable drag chains	
8CCH0020.11120-1	Hybrid cable for connecting 8BVE to 8CVI or 8DI, length 20 m, 2x 2x 0.34 mm <sup>2</sup> + 4x 0.75 mm <sup>2</sup> + 5x 2.5 mm <sup>2</sup> , 1x 15-pin female TYCO connector, 1x RJ45 connector, integrated shield fixing, can be used in cable drag chains	
8CCH0025.11120-1	Hybrid cable for connecting 8BVE to 8CVI or 8DI, length 25 m, 2x 2x 0.34 mm <sup>2</sup> + 4x 0.75 mm <sup>2</sup> + 5x 2.5 mm <sup>2</sup> , 1x 15-pin female TYCO connector, 1x RJ45 connector, integrated shield fixing, can be used in cable drag chains	

Table 191: 8CCH0005.11120-1, 8CCH0007.11120-1, 8CCH0010.11120-1, 8CCH0015.11120-1, 8CCH0020.11120-1, 8CCH0025.11120-1 - Order data

##### 8.1.1.2.1.3 Technical data

Order number	8CCH0005.11120-1	8CCH0007.11120-1	8CCH0010.11120-1	8CCH0015.11120-1	8CCH0020.11120-1	8CCH0025.11120-1
<b>General information</b>						
Cable cross section	5x 2.5 mm <sup>2</sup> + 2x 2x 0.75 mm <sup>2</sup> + 2x 2x 0.34 mm <sup>2</sup> / 1.55- 100 VZN					
Durability	In preparation					
Certification	E130266 cURus AWM style 20234, 80°C, 1000 V and CSA C22.2 No. 210.2 I/II A/B, FT1 <sup>1)</sup>					
Certifications						
CE	Yes					
UL	cULus E225616 Power conversion equipment					
EAC	Yes					

Table 192: 8CCH0005.11120-1, 8CCH0007.11120-1, 8CCH0010.11120-1, 8CCH0015.11120-1, 8CCH0020.11120-1, 8CCH0025.11120-1 - Technical data

## Accessories

Order number	8CCH0005. 11120-1	8CCH0007. 11120-1	8CCH0010. 11120-1	8CCH0015. 11120-1	8CCH0020. 11120-1	8CCH0025. 11120-1
<b>Cable construction</b>						
Power lines						
Quantity	5					
Wire insulation	PE					
Wire colors	Black, red, brown, white, yellow/green					
Variant	Tinned copper stranded wire					
Cross section	2.5 mm <sup>2</sup>					
Shield	No					
Stranding	No					
Signal line						
Quantity	4					
Wire insulation	PE					
Wire colors	Pink/Blue, violet/gray					
Variant	Tinned copper stranded wire					
Cross section	0.75 mm <sup>2</sup>					
Shield	No					
Stranding	No					
Data lines						
Quantity	4					
Wire insulation	PE					
Wire colors	VZN (cat. 5)					
Variant	Tinned copper stranded wire					
Cross section	0.34 mm <sup>2</sup>					
Shield	Yes					
Stranding	Yes					
Cable stranding	With filler elements and foil shield					
Cable shield	Tinned copper braiding, optical coverage >85% and foil shield					
Outer jacket						
Material	PUR					
Color	Orange, similar to RAL 2003 flat					
Labeling	B&R 5x2.5 + 2x2x0.75 + (1x4x22AWG) * E130266 cURus AWM STYLE 20234 * AWM I/II A/B 80°C 1000 V FT1 * "internal lot number" <sup>1)</sup>					
<b>Connector</b>						
Type	15-pin female TYCO connector					
Mating cycles	Max. 20					
Contacts	15					
Degree of protection per EN 60529	IP65					
<b>Electrical properties <sup>1)</sup></b>						
Operating voltage	Power lines: ≤1000 V Signal lines: ≤1000 V Data lines: ≤100 V					
Test voltage						
Wire - Wire	2.5 mm <sup>2</sup> : 3 kV 0.75 mm <sup>2</sup> : 2 kV 0.34 mm <sup>2</sup> : 2 kV					
Wire - Shield	2.5 mm <sup>2</sup> : 3 kV 0.75 mm <sup>2</sup> : 1 kV 0.34 mm <sup>2</sup> : 1 kV					
Conductor resistance						
Power lines	≤8 Ω/km					
Signal line	≤26 Ω/km					
Data lines	≤56 Ω/km					
Insulation resistance	≥500 MΩ*km					
Current-carrying capacity per DIN VDE 0298 part 4, table 11						
Wall mounting	23.7 A					
Installed in conduit or cable duct	27.3 A					
Installed in cable tray	29.1 A					
<b>Ambient conditions <sup>1)</sup></b>						
Temperature						
Moving	-40°C to +80°C					
Static	-40°C to +80°C					
<b>Mechanical properties <sup>1)</sup></b>						
Dimensions						
Length	5 m	7 m	10 m	15 m	20 m	25 m
Diameter	14.6 mm ±0.4 mm					
Bend radius						
Single bend	>60 mm					
Moving	≥150 mm					

Table 192: 8CCH0005.11120-1, 8CCH0007.11120-1, 8CCH0010.11120-1, 8CCH0015.11120-1, 8CCH0020.11120-1, 8CCH0025.11120-1 - Technical data

Order number	8CCH0005. 11120-1	8CCH0007. 11120-1	8CCH0010. 11120-1	8CCH0015. 11120-1	8CCH0020. 11120-1	8CCH0025. 11120-1
Drag chain data						
Acceleration	Max. 50 m/s <sup>2</sup> (depends on the length of the travel path)					
Flex cycles	≥5,000,000					
Velocity	Max. 300 m/min					
Weight	1.8 kg	2.5 kg	3.5 kg	5.3 kg	7 kg	8.8 kg

Table 192: 8CCH0005.11120-1, 8CCH0007.11120-1, 8CCH0010.11120-1,  
8CCH0015.11120-1, 8CCH0020.11120-1, 8CCH0025.11120-1 - Technical data

- 1) Values refer to the raw cable being used.

8.1.1.2.1.4 Wiring

**Cable construction**

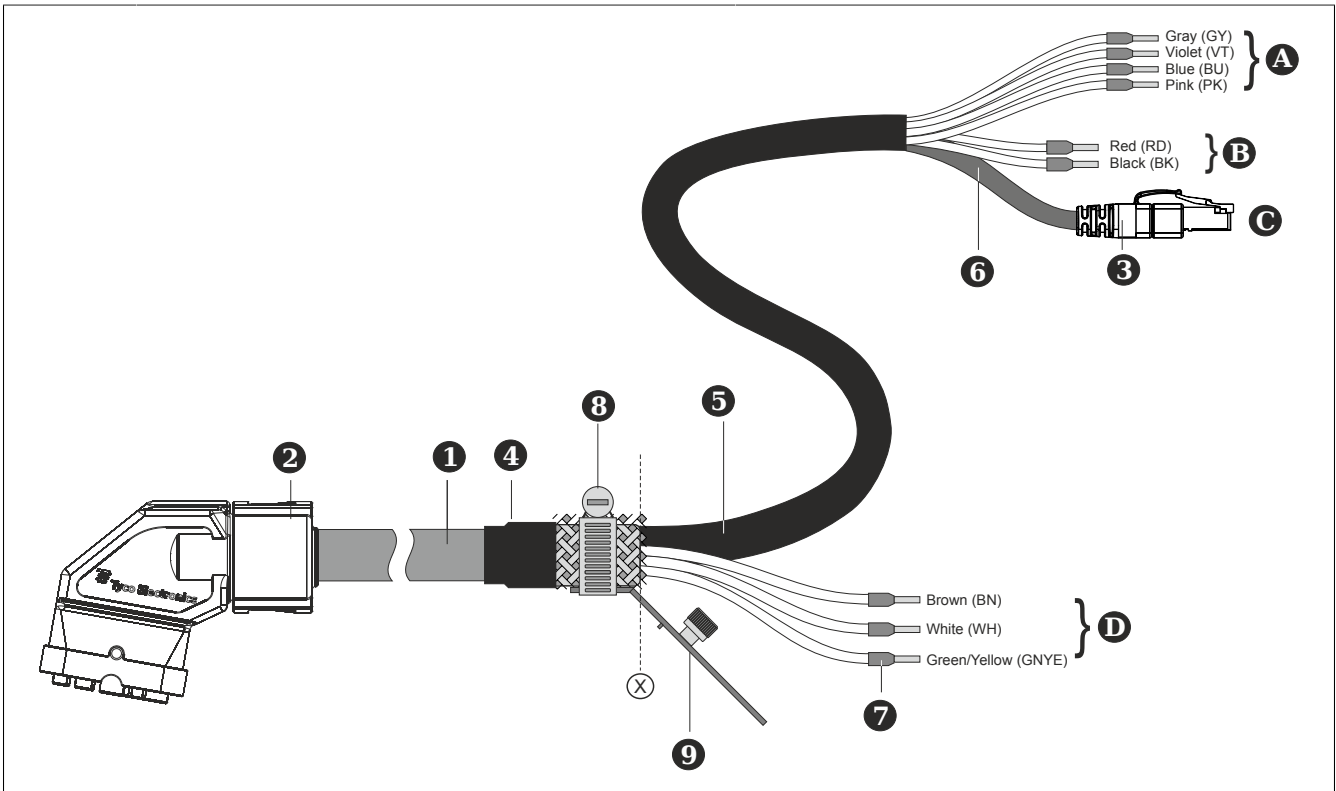

Pos.	Description	Note
1	Hybrid cable	5x 1x 2.5 mm <sup>2</sup> + 2x 2x 0.75 mm <sup>2</sup> + 2x 2x 0.34 mm <sup>2</sup> / 1.55- 100 LI
2	TE male hybrid connector	
3	RJ45 connector	
4	Heat shrink tubing	
5	Heat shrink tubing	330 mm
6	Heat shrink tubing	
7	Wire end sleeves	
8	Cable clamp	∅ 12-20 mm
9	Shield mounting	

Table 193: One-sided hybrid cable - Cable construction

Custom cable lengths		
From point	To point	Length
X	A	770 mm
X	B	510 mm
X	C	710 mm
X	D	140 mm

Table 194: Custom cable length

**RJ45 connector - Pinout**

Male connector	Pin	Description	Function
<p>12345678</p>	1	RXD	Receive signal
	2	RXD\	Receive signal inverted
	3	TXD	Transmit signal
	4	-	-
	5	-	-
	6	TXD\	Transmit signal inverted
	7	-	-
	8	-	-

Table 195: RJ45 connector - Pinout

**Cable diagram**

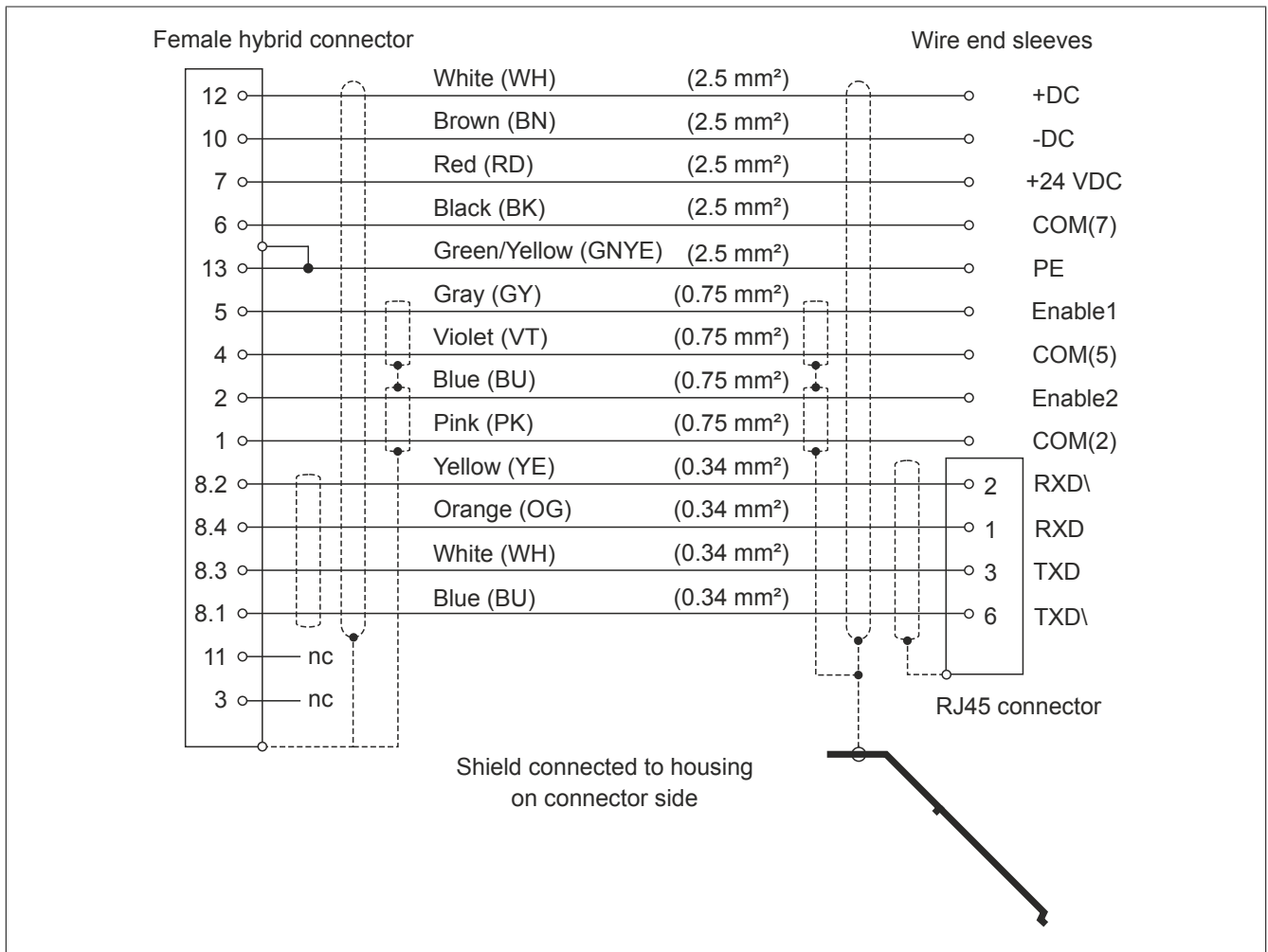

Figure 109: One-sided hybrid cable - Cable diagram

## 8.1.1.2.2 Hybrid cables

## 8.1.1.2.2.1 Order data

Order number	Short description	Figure
	<b>Hybrid cables</b>	
8CCH0005.11110-1	Hybrid cable, length 5 m, 2x 2x 0.34 mm <sup>2</sup> + 4x 0.75 mm <sup>2</sup> + 5x 2.5 mm <sup>2</sup> , 2x 15-pin female TYCO connector, can be used in cable drag chains	
8CCH0007.11110-1	Hybrid cable, length 7 m, 2x 2x 0.34 mm <sup>2</sup> + 4x 0.75 mm <sup>2</sup> + 5x 2.5 mm <sup>2</sup> , 2x 15-pin female TYCO connector, can be used in cable drag chains	
8CCH0010.11110-1	Hybrid cable, length 10 m, 2x 2x 0.34 mm <sup>2</sup> + 4x 0.75 mm <sup>2</sup> + 5x 2.5 mm <sup>2</sup> , 2x 15-pin female TYCO connector, can be used in cable drag chains	
8CCH0015.11110-1	Hybrid cable, length 15 m, 2x 2x 0.34 mm <sup>2</sup> + 4x 0.75 mm <sup>2</sup> + 5x 2.5 mm <sup>2</sup> , 2x 15-pin female TYCO connector, can be used in cable drag chains	
8CCH0020.11110-1	Hybrid cable, length 20 m, 2x 2x 0.34 mm <sup>2</sup> + 4x 0.75 mm <sup>2</sup> + 5x 2.5 mm <sup>2</sup> , 2x 15-pin female TYCO connector, can be used in cable drag chains	

Table 196: 8CCH0005.11110-1, 8CCH0007.11110-1, 8CCH0010.11110-1, 8CCH0015.11110-1, 8CCH0020.11110-1 - Order data

## 8.1.1.2.2.2 Technical data

Order number	8CCH0005.11110-1	8CCH0007.11110-1	8CCH0010.11110-1	8CCH0015.11110-1	8CCH0020.11110-1
<b>General information</b>					
Cable cross section	5x 2.5 mm <sup>2</sup> + 2x 2x 0.75 mm <sup>2</sup> + 2x 2x 0.34 mm <sup>2</sup> / 1.55- 100 VZN				
Durability	In preparation				
Certification	E130266 cURus AWM style 20234, 80°C, 1000 V and CSA C22.2 No. 210.2 I/II A/B, FT1 <sup>1)</sup>				
<b>Certifications</b>					
CE	Yes				
UL	cULus E225616 Power conversion equipment				
EAC	Yes				
<b>Cable construction</b>					
<b>Power lines</b>					
Quantity	5				
Wire insulation	PE				
Wire colors	Black, red, brown, white, yellow/green				
Variant	Tinned copper stranded wire				
Cross section	2.5 mm <sup>2</sup>				
Shield	No				
Stranding	No				
<b>Signal line</b>					
Quantity	4				
Wire insulation	PE				
Wire colors	Pink/Blue, violet/gray				
Variant	Tinned copper stranded wire				
Cross section	0.75 mm <sup>2</sup>				
Shield	No				
Stranding	No				
<b>Data lines</b>					
Quantity	4				
Wire insulation	PE				
Wire colors	VZN (cat. 5)				
Variant	Tinned copper stranded wire				
Cross section	0.34 mm <sup>2</sup>				
Shield	Yes				
Stranding	Yes				
Cable stranding	With filler elements and foil shield				
Cable shield	Tinned copper braiding, optical coverage >85% and foil shield				
<b>Outer jacket</b>					
Material	PUR				
Color	Orange, similar to RAL 2003 flat				
Labeling	B&R 5x2.5 + 2x2x0.75 + (1x4x22AWG) * E130266 cURus AWM STYLE 20234 * AWM I/II A/B 80°C 1000 V FT1 * "internal lot number" <sup>1)</sup>				
<b>Connector</b>					
Type	15-pin female TYCO connector				
Mating cycles	Max. 20				
Contacts	15				

Table 197: 8CCH0005.11110-1, 8CCH0007.11110-1, 8CCH0010.11110-1, 8CCH0015.11110-1, 8CCH0020.11110-1 - Technical data

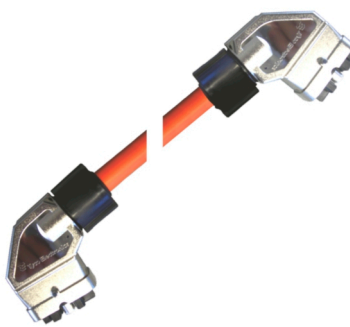
Order number	8CCH0005.11110-1	8CCH0007.11110-1	8CCH0010.11110-1	8CCH0015.11110-1	8CCH0020.11110-1
Degree of protection per EN 60529	IP65				
<b>Electrical properties <sup>1)</sup></b>					
Operating voltage	Power lines: ≤1000 V Signal lines: ≤1000 V Data lines: ≤100 V				
Test voltage					
Wire - Wire	2.5 mm <sup>2</sup> : 3 kV 0.75 mm <sup>2</sup> : 2 kV 0.34 mm <sup>2</sup> : 2 kV				
Wire - Shield	2.5 mm <sup>2</sup> : 3 kV 0.75 mm <sup>2</sup> : 1 kV 0.34 mm <sup>2</sup> : 1 kV				
Conductor resistance					
Power lines	≤8 Ω/km				
Signal line	≤26 Ω/km				
Data lines	≤56 Ω/km				
Insulation resistance	≥500 MΩ*km				
Current-carrying capacity per DIN VDE 0298 part 4, table 11					
Wall mounting	23.7 A				
Installed in conduit or cable duct	27.3 A				
Installed in cable tray	29.1 A				
<b>Ambient conditions <sup>1)</sup></b>					
Temperature					
Moving	-40°C to +80°C				
Static	-40°C to +80°C				
<b>Mechanical properties <sup>1)</sup></b>					
Dimensions					
Length	5 m	7 m	10 m	15 m	20 m
Diameter	14.6 mm ±0.4 mm				
Bend radius					
Single bend	>60 mm				
Moving	≥150 mm		≥160 mm		≥150 mm
Drag chain data					
Acceleration	Max. 50 m/s <sup>2</sup> (depends on the length of the travel path)				
Flex cycles	≥5,000,000				
Velocity	Max. 300 m/min				
Weight	1.8 kg	2.5 kg	3.5 kg	5.3 kg	7 kg

Table 197: 8CCH0005.11110-1, 8CCH0007.11110-1, 8CCH0010.11110-1, 8CCH0015.11110-1, 8CCH0020.11110-1 - Technical data

1) Values refer to the raw cable being used.

### 8.1.1.2.2.3 Cable construction

Pos.	Description	Note
1	Hybrid cable	5x 2.5 mm <sup>2</sup> + 2x 2x 0.75 mm <sup>2</sup> + 2x 2x 0.34 mm <sup>2</sup> / 1.55- 100 VZN
2	15-pin female TYCO connector	Dimensions: 82.6 x 67.6 x 36.2 mm

Table 198: Hybrid cables - Cable construction

### 8.1.1.2.2.4 Cable diagram

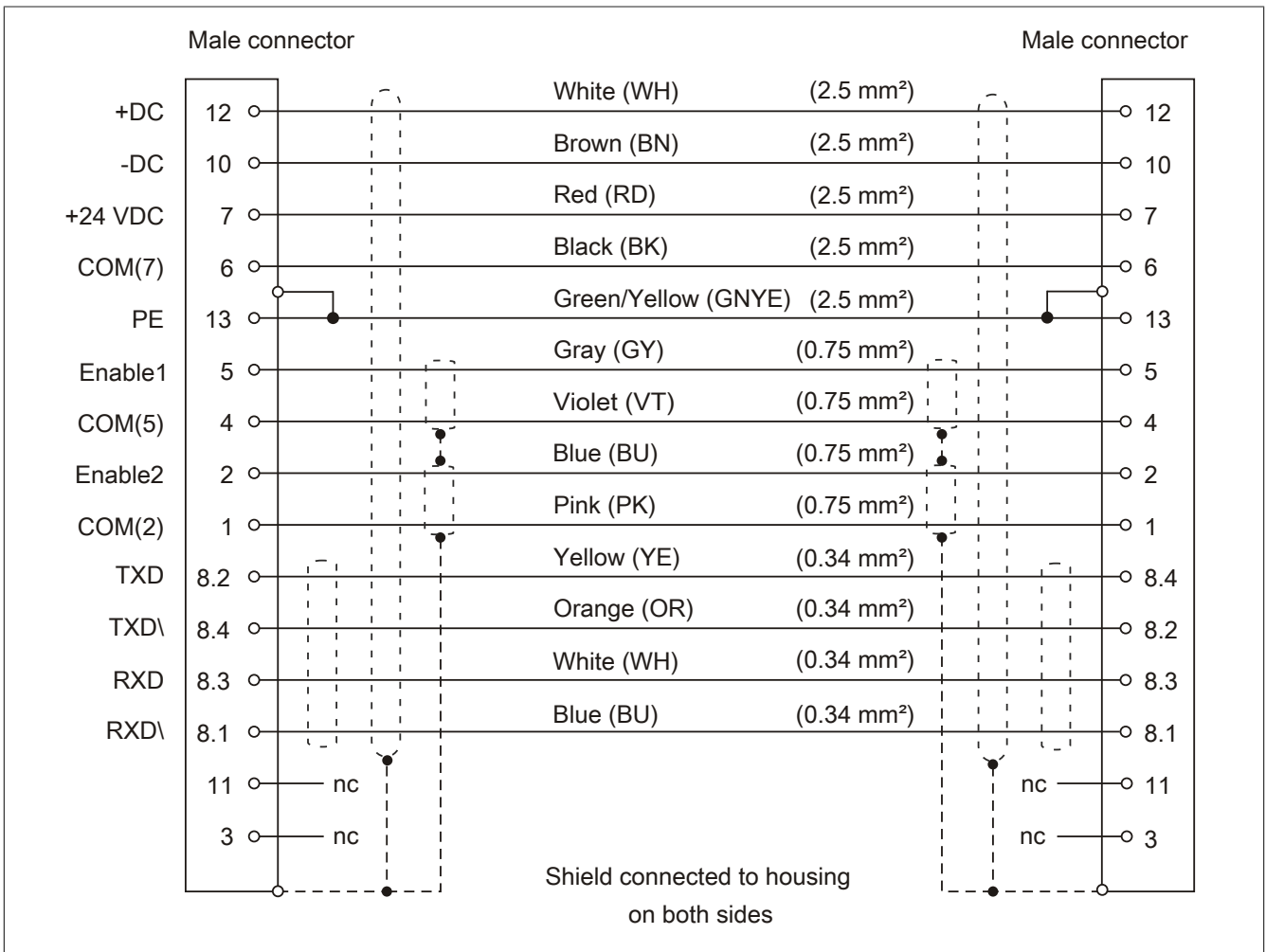

Figure 110: Hybrid cables - Cable diagram

### 8.1.1.2.3 Hybrid cable, 1x connector insert, rotated

#### 8.1.1.2.3.1 Order data

Order number	Short description	Figure
	<b>Hybrid cables</b>	
8CCH0001.11130-1	Hybrid cable, length 1 m, 2x 2x 0.34 mm <sup>2</sup> + 4x 0.75 mm <sup>2</sup> + 5x 2.5 mm <sup>2</sup> , 2x 15-pin female TYCO connector, 1x connector insert rotated 180°, can be used in cable drag chains	
8CCH0002.11130-1	Hybrid cable, length 2 m, 2x 2x 0.34 mm <sup>2</sup> + 4x 0.75 mm <sup>2</sup> + 5x 2.5 mm <sup>2</sup> , 2x 15-pin female TYCO connector, 1x connector insert rotated 180°, can be used in cable drag chains	
8CCH0003.11130-1	Hybrid cable, length 3 m, 2x 2x 0.34 mm <sup>2</sup> + 4x 0.75 mm <sup>2</sup> + 5x 2.5 mm <sup>2</sup> , 2x 15-pin female TYCO connector, 1x connector insert rotated 180°, can be used in cable drag chains	
8CCH0004.11130-1	Hybrid cable, length 4 m, 2x 2x 0.34 mm <sup>2</sup> + 4x 0.75 mm <sup>2</sup> + 5x 2.5 mm <sup>2</sup> , 2x 15-pin female TYCO connector, 1x connector insert rotated 180°, can be used in cable drag chains	
8CCH0005.11130-1	Hybrid cable, length 5 m, 2x 2x 0.34 mm <sup>2</sup> + 4x 0.75 mm <sup>2</sup> + 5x 2.5 mm <sup>2</sup> , 2x 15-pin female TYCO connector, 1x connector insert rotated 180°, can be used in cable drag chains	

Table 199: 8CCH0001.11130-1, 8CCH0002.11130-1, 8CCH0003.11130-1, 8CCH0004.11130-1, 8CCH0005.11130-1 - Order data

## 8.1.1.2.3.2 Technical data

Order number	8CCH0001.11130-1	8CCH0002.11130-1	8CCH0003.11130-1	8CCH0004.11130-1	8CCH0005.11130-1
<b>General information</b>					
Cable cross section	5x 2.5 mm <sup>2</sup> + 2x 2x 0.75 mm <sup>2</sup> + 2x 2x 0.34 mm <sup>2</sup> / 1.55- 100 VZN				
Durability	In preparation				
Short description	Connector insert in hybrid connector rotated 180° degrees				
Certification	E130266 cURus AWM style 20234, 80°C, 1000 V and CSA C22.2 No. 210.2 I/II A/B, FT1 <sup>1)</sup>				
Certifications					
CE	Yes				
UL	cULus E225616 Power conversion equipment				
EAC	Yes				
<b>Cable construction</b>					
Power lines					
Quantity	5				
Wire insulation	PE				
Wire colors	Black, red, brown, white, yellow/green				
Variant	Tinned copper stranded wire				
Cross section	2.5 mm <sup>2</sup>				
Shield	No				
Stranding	No				
Signal line					
Quantity	4				
Wire insulation	PE				
Wire colors	Pink/Blue, violet/gray				
Variant	Tinned copper stranded wire				
Cross section	0.75 mm <sup>2</sup>				
Shield	No				
Stranding	No				
Data lines					
Quantity	4				
Wire insulation	PE				
Wire colors	VZN (cat. 5)				
Variant	Tinned copper stranded wire				
Cross section	0.34 mm <sup>2</sup>				
Shield	Yes				
Stranding	Yes				
Cable stranding	With filler elements and foil shield				
Cable shield	Tinned copper braiding, optical coverage >85% and foil shield				
Outer jacket					
Material	PUR				
Color	Orange, similar to RAL 2003 flat				
Labeling	B&R 5x2.5 + 2x2x0.75 + (1x4x22AWG) * E130266 cURus AWM STYLE 20234 * AWM I/II A/B 80°C 1000 V FT1 * "internal lot number" <sup>1)</sup>				
<b>Connector</b>					
Type	15-pin female TYCO connector				
Mating cycles	Max. 20				
Contacts	15				
Degree of protection per EN 60529	IP65				
<b>Electrical properties <sup>1)</sup></b>					
Operating voltage	Power lines: ≤1000 V Signal lines: ≤1000 V Data lines: ≤100 V				
Test voltage					
Wire - Wire	2.5 mm <sup>2</sup> : 3 kV 0.75 mm <sup>2</sup> : 2 kV 0.34 mm <sup>2</sup> : 2 kV				
Wire - Shield	2.5 mm <sup>2</sup> : 3 kV 0.75 mm <sup>2</sup> : 1 kV 0.34 mm <sup>2</sup> : 1 kV				
Conductor resistance					
Power lines	≤8 Ω/km				
Signal line	≤26 Ω/km				
Data lines	≤56 Ω/km				
Insulation resistance	≥500 MΩ*km				
Current-carrying capacity per DIN VDE 0298 part 4, table 11					
Wall mounting	23.7 A				
Installed in conduit or cable duct	27.3 A				
Installed in cable tray	29.1 A				

Table 200: 8CCH0001.11130-1, 8CCH0002.11130-1, 8CCH0003.11130-1, 8CCH0004.11130-1, 8CCH0005.11130-1 - Technical data

## Accessories

Order number	8CCH0001.11130-1	8CCH0002.11130-1	8CCH0003.11130-1	8CCH0004.11130-1	8CCH0005.11130-1
<b>Ambient conditions <sup>1)</sup></b>					
Temperature					
Moving	-40°C to +80°C				
Static	-40°C to +80°C				
<b>Mechanical properties <sup>1)</sup></b>					
Dimensions					
Length	1 m	2 m	3 m	4 m	5 m
Diameter	14.6 mm ±0.4 mm				
Bend radius					
Single bend	>60 mm				
Moving	≥150 mm				
Drag chain data					
Acceleration	Max. 50 m/s <sup>2</sup> (depends on the length of the travel path)				
Flex cycles	≥5,000,000				
Velocity	Max. 300 m/min				
Weight	0.4 kg	0.7 kg	1.1 kg	1.4 kg	1.8 kg

Table 200: 8CCH0001.11130-1, 8CCH0002.11130-1, 8CCH0003.11130-1, 8CCH0004.11130-1, 8CCH0005.11130-1 - Technical data

1) Values refer to the raw cable being used.

### 8.1.1.2.3.3 Cable construction

Pos.	Description	Note
1	Hybrid cable	5x 1x 2.5 mm <sup>2</sup> + 4x 1x 0.75 mm <sup>2</sup> + 2x 2x 0.34 mm <sup>2</sup> / 1.55- 100 LI
2	15-pin female TYCO connector	Connector insert in hybrid connector rotated 180° degrees Dimensions: 82.6 x 67.6 x 36.2 mm

Table 201: Hybrid cables - Cable construction

## 8.1.1.2.3.4 Cable diagram

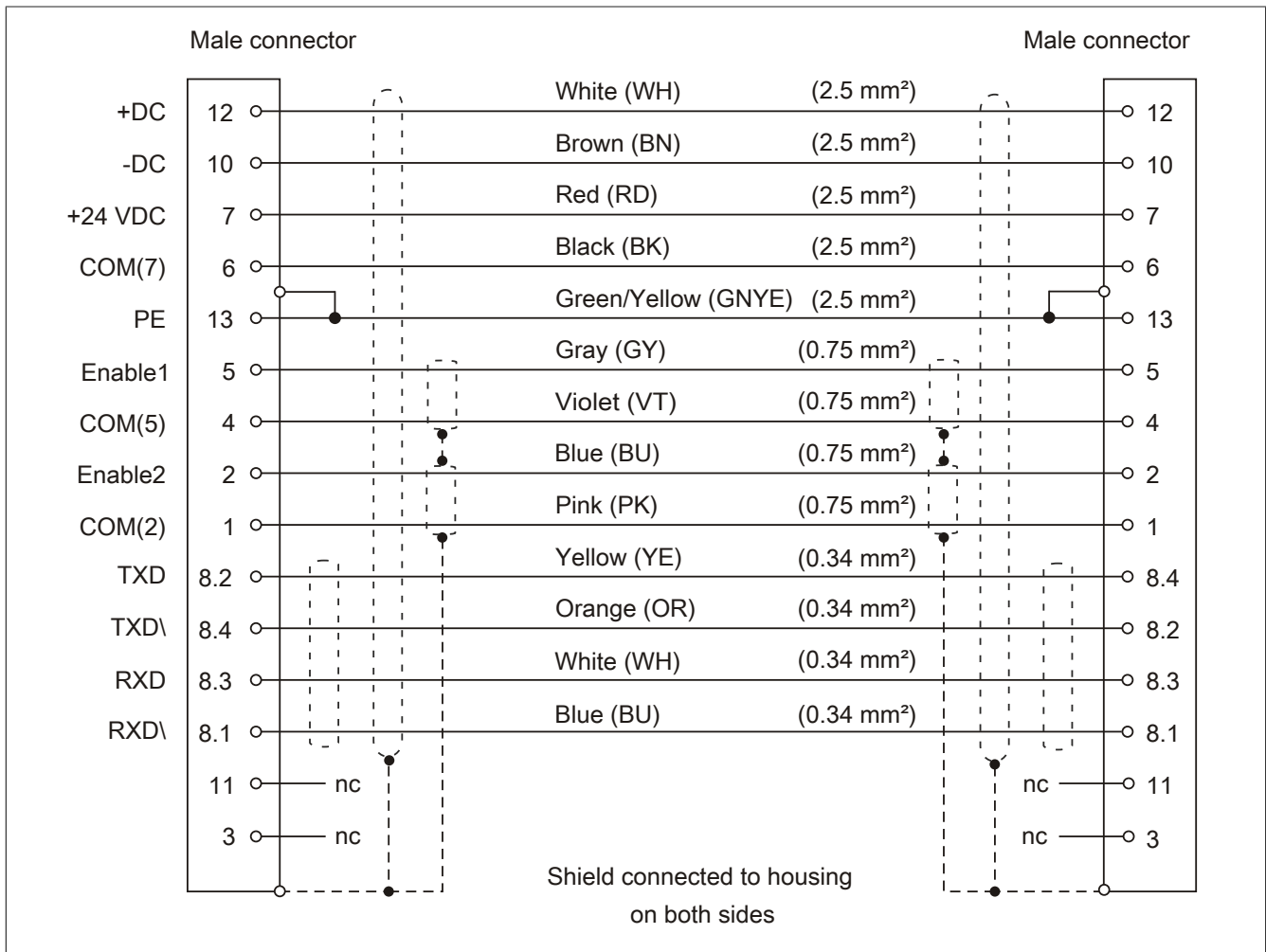

Figure 111: Hybrid cables - Cable diagram

## 8.1.1.2.4 Hybrid cable, 2x connector insert, rotated

## 8.1.1.2.4.1 Order data

Order number	Short description	Figure
	<b>Hybrid cables</b>	
8CCH0001.11230-1	Hybrid cable, length 1 m, 2x 2x 0.34 mm <sup>2</sup> + 4x 0.75 mm <sup>2</sup> + 5x 2.5 mm <sup>2</sup> , 2x 15-pin female TYCO connector, connector insert rotated 180°, can be used in cable drag chains	
8CCH0002.11230-1	Hybrid cable, length 2 m, 2x 2x 0.34 mm <sup>2</sup> + 4x 0.75 mm <sup>2</sup> + 5x 2.5 mm <sup>2</sup> , 2x 15-pin female TYCO connector, connector insert rotated 180°, can be used in cable drag chains	
8CCH0003.11230-1	Hybrid cable, length 3 m, 2x 2x 0.34 mm <sup>2</sup> + 4x 0.75 mm <sup>2</sup> + 5x 2.5 mm <sup>2</sup> , 2x 15-pin female TYCO connector, connector insert rotated 180°, can be used in cable drag chains	
8CCH0004.11230-1	Hybrid cable, length 4 m, 2x 2x 0.34 mm <sup>2</sup> + 4x 0.75 mm <sup>2</sup> + 5x 2.5 mm <sup>2</sup> , 2x 15-pin female TYCO connector, connector insert rotated 180°, can be used in cable drag chains	
8CCH0005.11230-1	Hybrid cable, length 5 m, 2x 2x 0.34 mm <sup>2</sup> + 4x 0.75 mm <sup>2</sup> + 5x 2.5 mm <sup>2</sup> , 2x 15-pin female TYCO connector, connector insert rotated 180°, can be used in cable drag chains	

Table 202: 8CCH0001.11230-1, 8CCH0002.11230-1, 8CCH0003.11230-1, 8CCH0004.11230-1, 8CCH0005.11230-1 - Order data

## 8.1.1.2.4.2 Technical data

Order number	8CCH0001.11230-1	8CCH0002.11230-1	8CCH0003.11230-1	8CCH0004.11230-1	8CCH0005.11230-1
<b>General information</b>					
Cable cross section	5x 2.5 mm <sup>2</sup> + 2x 2x 0.75 mm <sup>2</sup> + 2x 2x 0.34 mm <sup>2</sup> / 1.55- 100 VZN				
Durability	In preparation				
Short description	Connector insert in both hybrid connectors rotated 180° degrees				
Certification	E130266 cURus AWM style 20234, 80°C, 1000 V and CSA C22.2 No. 210.2 I/II A/B, FT1 <sup>1)</sup>				
Certifications					
CE	Yes				
UL	cULus E225616 Power conversion equipment				
EAC	Yes				
<b>Cable construction</b>					
Power lines					
Quantity	5				
Wire insulation	PE				
Wire colors	Black, red, brown, white, yellow/green				
Variant	Tinned copper stranded wire				
Cross section	2.5 mm <sup>2</sup>				
Shield	No				
Stranding	No				
Signal line					
Quantity	4				
Wire insulation	PE				
Wire colors	Pink/Blue, violet/gray				
Variant	Tinned copper stranded wire				
Cross section	0.75 mm <sup>2</sup>				
Shield	No				
Stranding	No				
Data lines					
Quantity	4				
Wire insulation	PE				
Wire colors	VZN (cat. 5)				
Variant	Tinned copper stranded wire				
Cross section	0.34 mm <sup>2</sup>				
Shield	Yes				
Stranding	Yes				
Cable stranding	With filler elements and foil shield				
Cable shield	Tinned copper braiding, optical coverage >85% and foil shield				
Outer jacket					
Material	PUR				
Color	Orange, similar to RAL 2003 flat				
Labeling	B&R 5x2.5 + 2x2x0.75 + (1x4x22AWG) * E130266 cURus AWM STYLE 20234 * AWM I/II A/B 80°C 1000 V FT1 * "internal lot number" <sup>1)</sup>				
<b>Connector</b>					
Type	15-pin female TYCO connector				
Mating cycles	Max. 20				
Contacts	15				
Degree of protection per EN 60529	IP65				
<b>Electrical properties <sup>1)</sup></b>					
Operating voltage	Power lines: ≤1000 V Signal lines: ≤1000 V Data lines: ≤100 V				
Test voltage					
Wire - Wire	2.5 mm <sup>2</sup> : 3 kV 0.75 mm <sup>2</sup> : 2 kV 0.34 mm <sup>2</sup> : 2 kV				
Wire - Shield	2.5 mm <sup>2</sup> : 3 kV 0.75 mm <sup>2</sup> : 1 kV 0.34 mm <sup>2</sup> : 1 kV				
Conductor resistance					
Power lines	≤8 Ω/km				
Signal line	≤26 Ω/km				
Data lines	≤56 Ω/km				
Insulation resistance	≥500 MΩ*km				
Current-carrying capacity per DIN VDE 0298 part 4, table 11					
Wall mounting	23.7 A				
Installed in conduit or cable duct	27.3 A				
Installed in cable tray	29.1 A				

Table 203: 8CCH0001.11230-1, 8CCH0002.11230-1, 8CCH0003.11230-1, 8CCH0004.11230-1, 8CCH0005.11230-1 - Technical data

Order number	8CCH0001.11230-1	8CCH0002.11230-1	8CCH0003.11230-1	8CCH0004.11230-1	8CCH0005.11230-1
<b>Ambient conditions <sup>1)</sup></b>					
Temperature					
Moving	-40°C to +80°C				
Static	-40°C to +80°C				
<b>Mechanical properties <sup>1)</sup></b>					
Dimensions					
Length	1 m	2 m	3 m	4 m	5 m
Diameter	14.6 mm ±0.4 mm				
Bend radius					
Single bend	>60 mm				
Moving	≥150 mm				
Drag chain data					
Acceleration	Max. 50 m/s <sup>2</sup> (depends on the length of the travel path)				
Flex cycles	≥5,000,000				
Velocity	Max. 300 m/min				
Weight	0.4 kg	0.7 kg	1.1 kg	1.4 kg	1.8 kg

Table 203: 8CCH0001.11230-1, 8CCH0002.11230-1, 8CCH0003.11230-1, 8CCH0004.11230-1, 8CCH0005.11230-1 - Technical data

1) Values refer to the raw cable being used.

### 8.1.1.2.4.3 Cable construction

		
Pos.	Description	Note
1	Hybrid cable	5x 1x 2.5 mm <sup>2</sup> + 4x 1x 0.75 mm <sup>2</sup> + 2x 2x 0.34 mm <sup>2</sup> / 1.55- 100 LI
2	15-pin female TYCO connector	Connector inserts rotated 180° Dimensions: 82.6 x 67.6 x 36.2 mm

Table 204: Hybrid cables - Cable construction

8.1.1.2.4.4 Cable diagram

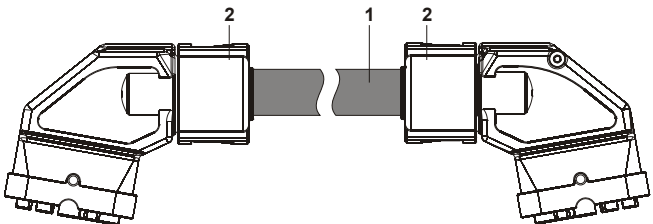
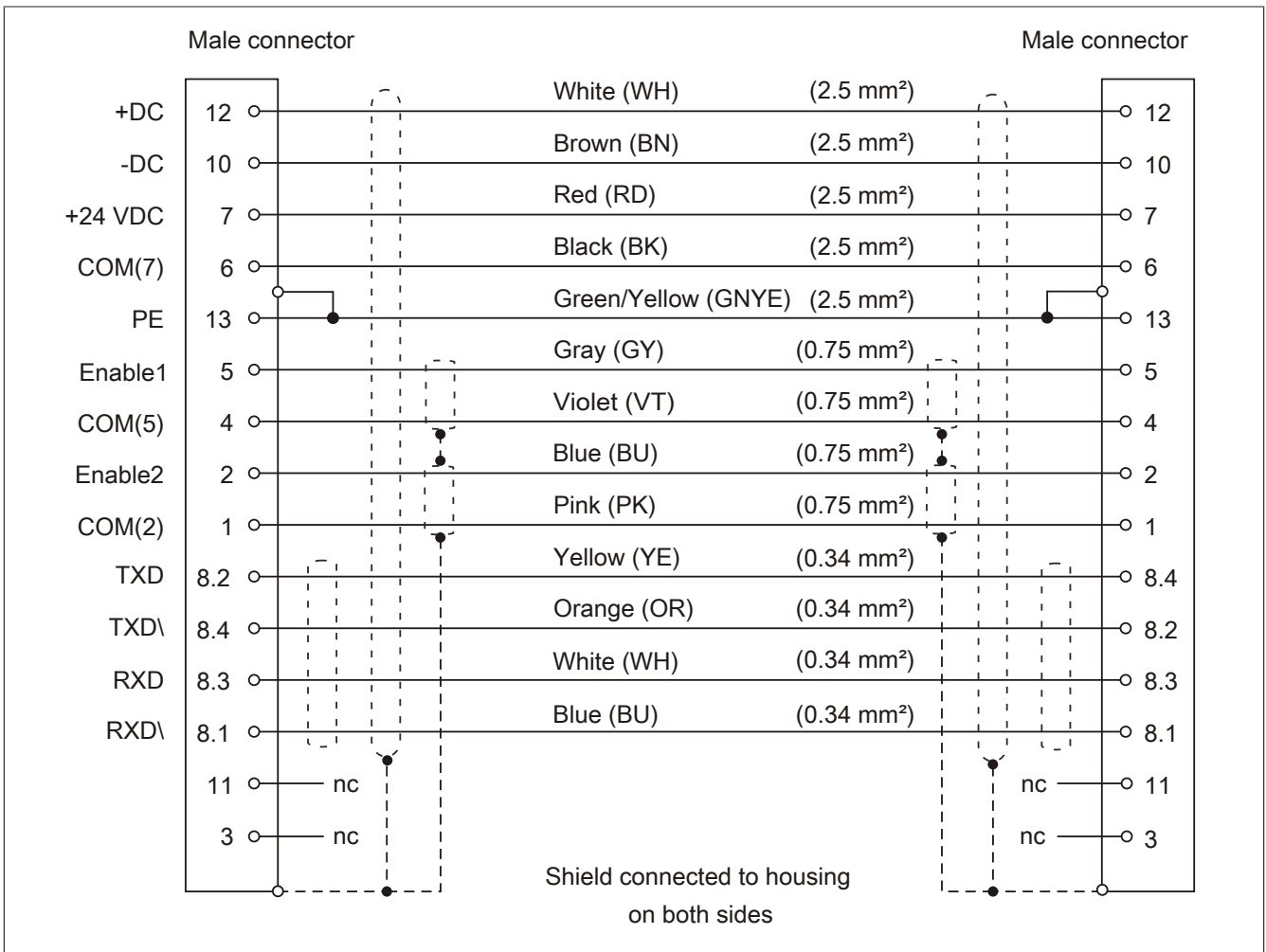

Figure 112: Hybrid cables - Cable diagram

8.1.1.2.5 Hybrid cable, one-sided, 1x connector insert, rotated

8.1.1.2.5.1 Order data

Order number	Short description	Figure
	<b>8BVE / 8CVI connection cables</b>	
8CCH0005.11220-1	Hybrid cable for connecting 8BVE to 8CVI or 8DI, length 5 m, 2x 2x 0.34 mm² + 4x 0.75 mm² + 5x 2.5 mm², 1x 15-pin female TYCO connector, connector insert rotated 180°, can be used in cable drag chains	
8CCH0007.11220-1	Hybrid cable for connecting 8BVE to 8CVI or 8DI, length 7 m, 2x 2x 0.34 mm² + 4x 0.75 mm² + 5x 2.5 mm², 1x 15-pin female TYCO connector, connector insert rotated 180°, can be used in cable drag chains	
8CCH0010.11220-1	Hybrid cable for connecting 8BVE to 8CVI or 8DI, length 10 m, 2x 2x 0.34 mm² + 4x 0.75 mm² + 5x 2.5 mm², 1x 15-pin female TYCO connector, connector insert rotated 180°, can be used in cable drag chains	
8CCH0015.11220-1	Hybrid cable for connecting 8BVE to 8CVI or 8DI, length 15 m, 2x 2x 0.34 mm² + 4x 0.75 mm² + 5x 2.5 mm², 1x 15-pin female TYCO connector, connector insert rotated 180°, can be used in cable drag chains	
8CCH0020.11220-1	Hybrid cable for connecting 8BVE to 8CVI or 8DI, length 20 m, 2x 2x 0.34 mm² + 4x 0.75 mm² + 5x 2.5 mm², 1x 15-pin female TYCO connector, connector insert rotated 180°, can be used in cable drag chains	

Table 205: 8CCH0005.11220-1, 8CCH0007.11220-1, 8CCH0010.11220-1, 8CCH0015.11220-1, 8CCH0020.11220-1 - Order data

## 8.1.1.2.5.2 Technical data

Order number	8CCH0005.11220-1	8CCH0007.11220-1	8CCH0010.11220-1	8CCH0015.11220-1	8CCH0020.11220-1
<b>General information</b>					
Cable cross section	5x 2.5 mm <sup>2</sup> + 2x 2x 0.75 mm <sup>2</sup> + 2x 2x 0.34 mm <sup>2</sup> / 1.55- 100 VZN				
Durability	In preparation				
Certification	E130266 cRUus AWM style 20234, 80°C, 1000 V and CSA C22.2 No. 210.2 I/II A/B, FT1 <sup>1)</sup>				
Certifications					
CE	Yes				
UL	cULus E225616 Power conversion equipment				
EAC	-	Yes	-	Yes	-
<b>Cable construction</b>					
Power lines					
Quantity	5				
Wire insulation	PE				
Wire colors	Black, red, brown, white, yellow/green				
Variant	Tinned copper stranded wire				
Cross section	2.5 mm <sup>2</sup>				
Shield	No				
Stranding	No				
Signal line					
Quantity	4				
Wire insulation	PE				
Wire colors	Pink/Blue, violet/gray				
Variant	Tinned copper stranded wire				
Cross section	0.75 mm <sup>2</sup>				
Shield	No				
Stranding	No				
Data lines					
Quantity	4				
Wire insulation	PE				
Wire colors	VZN (cat. 5)				
Variant	Tinned copper stranded wire				
Cross section	0.34 mm <sup>2</sup>				
Shield	Yes				
Stranding	Yes				
Cable stranding	With filler elements and foil shield				
Cable shield	Tinned copper braiding, optical coverage >85% and foil shield				
Outer jacket					
Material	PUR				
Color	Orange, similar to RAL 2003 flat				
Labeling	B&R 5x2.5 + 2x2x0.75 + (1x4x22AWG) * E130266 cRUus AWM STYLE 20234 * AWM I/II A/B 80°C 1000 V FT1 * "internal lot number" <sup>1)</sup>				
<b>Connector</b>					
Type	15-pin female TYCO connector				
Mating cycles	Max. 20				
Contacts	15				
Degree of protection per EN 60529	IP65 when connected				
<b>Electrical properties <sup>1)</sup></b>					
Operating voltage	Power lines: ≤1000 V Signal lines: ≤1000 V Data lines: ≤100 V				
Test voltage					
Wire - Wire	2.5 mm <sup>2</sup> : 3 kV 0.75 mm <sup>2</sup> : 2 kV 0.34 mm <sup>2</sup> : 2 kV				
Wire - Shield	2.5 mm <sup>2</sup> : 3 kV 0.75 mm <sup>2</sup> : 1 kV 0.34 mm <sup>2</sup> : 1 kV				
Current-carrying capacity	20 A				
Conductor resistance					
Power lines	≤8 Ω/km				
Signal line	≤26 Ω/km				
Data lines	≤56 Ω/km				
Insulation resistance	≥500 MΩ*km				
<b>Ambient conditions <sup>1)</sup></b>					
Temperature					
Moving	-40°C to 80°C				
Static	-40°C to 80°C				
<b>Mechanical properties <sup>1)</sup></b>					
Dimensions					
Length	5 m	7 m	10 m	15 m	20 m
Diameter	14.6 mm ±0.4 mm				

Table 206: 8CCH0005.11220-1, 8CCH0007.11220-1, 8CCH0010.11220-1, 8CCH0015.11220-1, 8CCH0020.11220-1 - Technical data

## Accessories

Order number	8CCH0005.11220-1	8CCH0007.11220-1	8CCH0010.11220-1	8CCH0015.11220-1	8CCH0020.11220-1
Bend radius					
Single bend	>40 mm				
Moving	≥140 mm				
Drag chain data					
Acceleration	Max. 50 m/s <sup>2</sup> (depends on the length of the travel path)				
Flex cycles	≥5,000,000				
Velocity	Max. 300 m/min				
Weight	1.8 kg	2.5 kg	3.5 kg	5.3 kg	7.3 kg

Table 206: 8CCH0005.11220-1, 8CCH0007.11220-1, 8CCH0010.11220-1, 8CCH0015.11220-1, 8CCH0020.11220-1 - Technical data

1) Values refer to the raw cable being used.

### 8.1.1.2.5.3 Cable construction

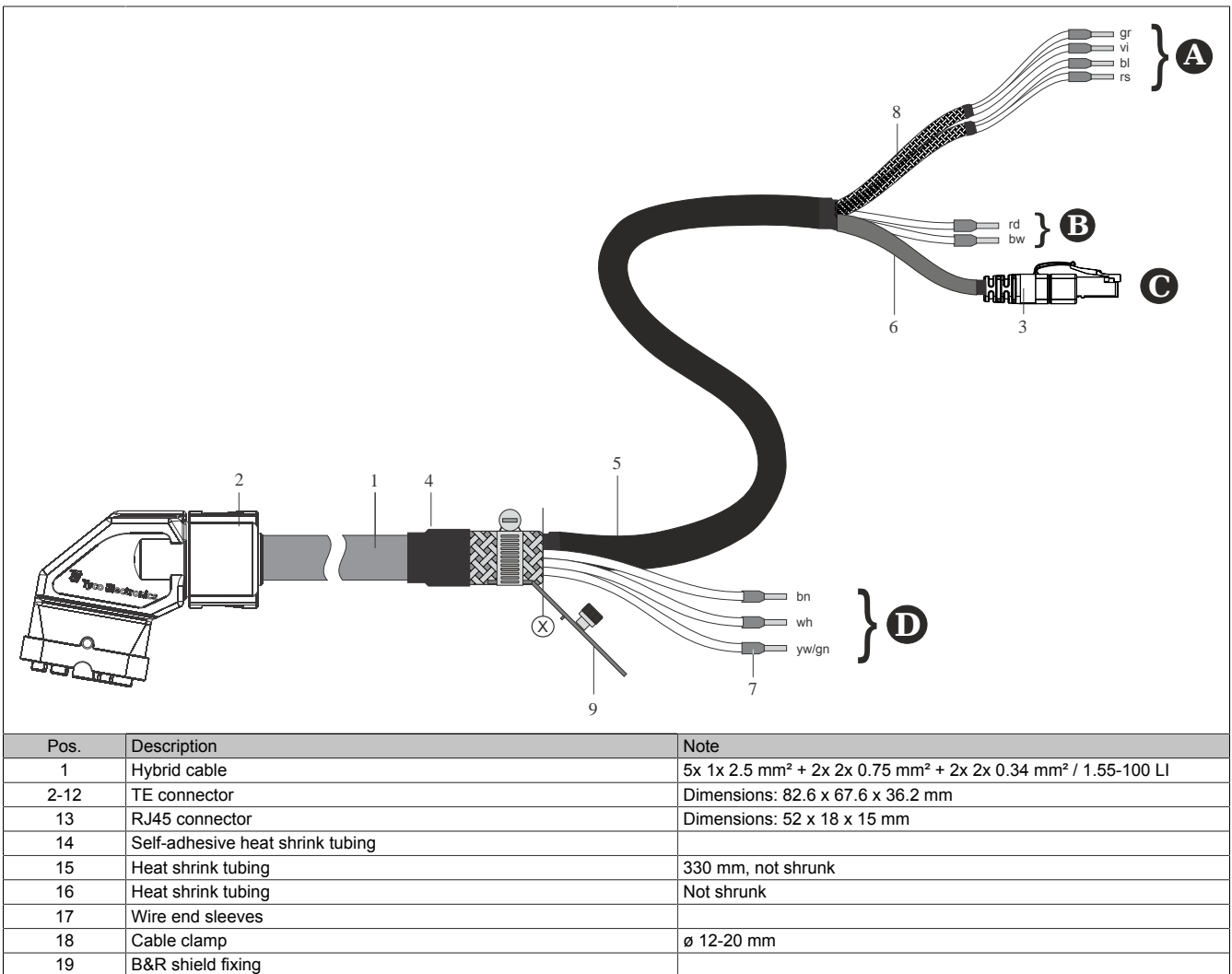

Table 207: One-sided hybrid cable 8CCHxxxx.11220-1 - Cable construction

8.1.1.2.5.4 Cable diagram

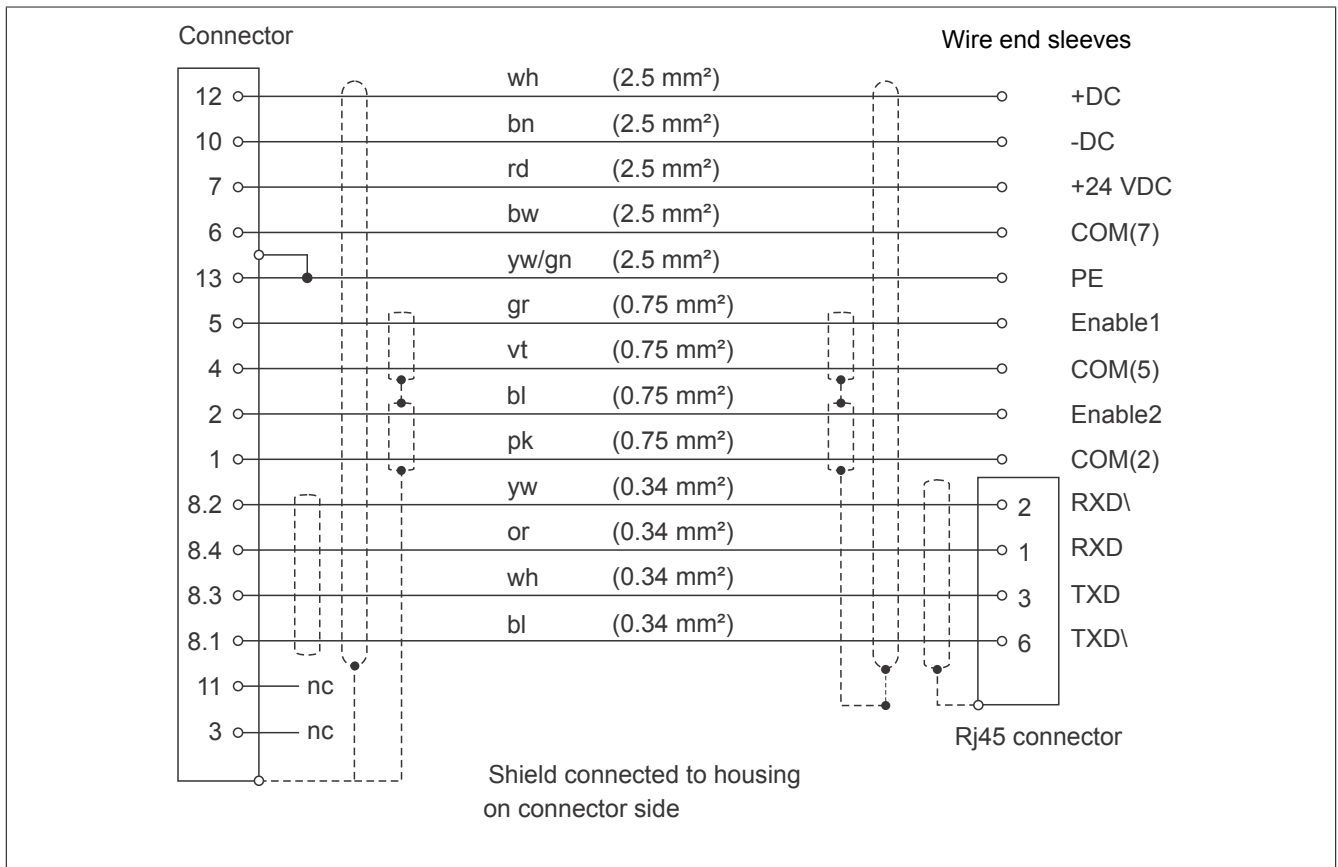

Figure 113: One-sided hybrid cable 8CCHxxxx.11220-1 - Cable diagram

### 8.1.1.3 Fan kits

#### 8.1.1.3.1 General information

8DI ACOPOSmotor modules can be optionally equipped with a fan kit depending on size. The fan kit considerably improves the nominal values of 8DI ACOPOSmotor modules (see speed-torque characteristic curve for the respective 8DI ACOPOSmotor module).

#### Information:

ACOPOSmotor 8DI modules automatically take into account the improvement of rated values with fan kit 8ZDFB via the evaluation of the module-internal temperature sensor. The motor parameters therefore do not need to be adjusted in Automation Studio.

A separate data set is available in SERVOfsoft for ACOPOSmotor 8DI modules with and without fan kit 8ZDFB.

#### 8.1.1.3.1.1 Size 4 - 8ZDFB4000000.000-0

#### Order data

Order number	Short description	Figure
8ZDFB4000000.000-0	Fan kits ACOPOSmotor fan kit for 8DI4xx modules	

Table 208: 8ZDFB4000000.000-0 - Order data

#### Technical data

Order number	8ZDFB4000000.000-0
<b>General information</b>	
Short description	ACOPOSmotor fan kit for 8DI4xx modules
<b>24 VDC power supply</b>	
Input voltage	24 VDC +10% / -50%
Max. power consumption	5.5 W
Variant	M8 4-pin male connector, 90° angled
<b>Operating conditions</b>	
Installation elevation above sea level	
Nominal	0 to 500 m
Maximum	4000 m
Degree of protection per EN 60529	IP24
<b>Ambient conditions</b>	
Temperature	
Storage	-20 to 55°C
Transport	-20 to 70°C
Relative humidity	
Operation	15 to 90%, non-condensing
Storage	15 to 90%, non-condensing
Transport	In preparation
<b>Mechanical properties</b>	
Volumetric flow rate	2.486 m <sup>3</sup> /min
Operating noise	47 dB(A)
Service life	
At 40°C	80,000 h
Dimensions	
Width	125 mm
Height	131 mm
Depth	143.5 mm
Weight	0.43 kg

Table 209: 8ZDFB4000000.000-0 - Technical data

**Dimension diagram**

Figure 114: 8ZDFB4000000.000-0 - Dimensions

**8.1.1.3.1.2 Size 5 - 8ZDFB5000000.000-0****Order data**

Order number	Short description	Figure
8ZDFB5000000.000-0	ACOPOSmotor fan kit for 8DI5xx modules	

Table 210: 8ZDFB5000000.000-0 - Order data

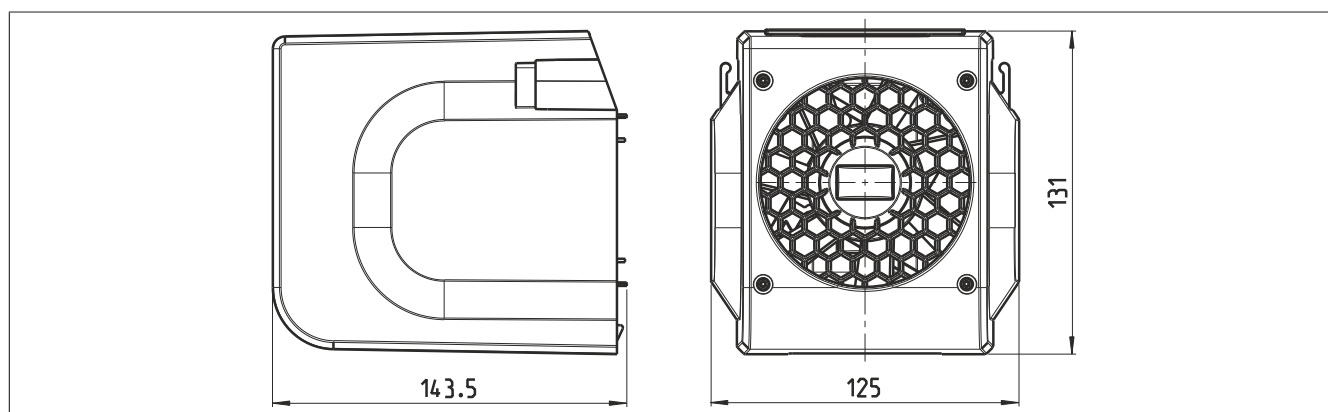
**Technical data**

Order number	8ZDFB5000000.000-0
<b>General information</b>	
Short description	ACOPOSmotor fan kit for 8DI5xx modules
<b>24 VDC power supply</b>	
Input voltage	24 VDC +10% / -50%
Max. power consumption	7.4 W
Variant	M8 4-pin male connector, 90° angled
<b>Operating conditions</b>	
Installation elevation above sea level	
Nominal	0 to 500 m
Maximum	4000 m
Degree of protection per EN 60529	IP24
<b>Ambient conditions</b>	
Temperature	
Storage	-20 to 55°C
Transport	-20 to 75°C
Relative humidity	
Operation	15 to 90%, non-condensing
Storage	15 to 90%, non-condensing
Transport	In preparation
<b>Mechanical properties</b>	
Volumetric flow rate	3.256 m³/min
Operating noise	47 dB(A)
Service life	
At 40°C	75,000 h

Table 211: 8ZDFB5000000.000-0 - Technical data

## Accessories

Order number	8ZDFB5000000.000-0
Dimensions	
Width	167 mm
Height	173.1 mm
Depth	143 mm
Weight	0.57 kg

Table 211: 8ZDFB5000000.000-0 - Technical data

### Dimension diagram

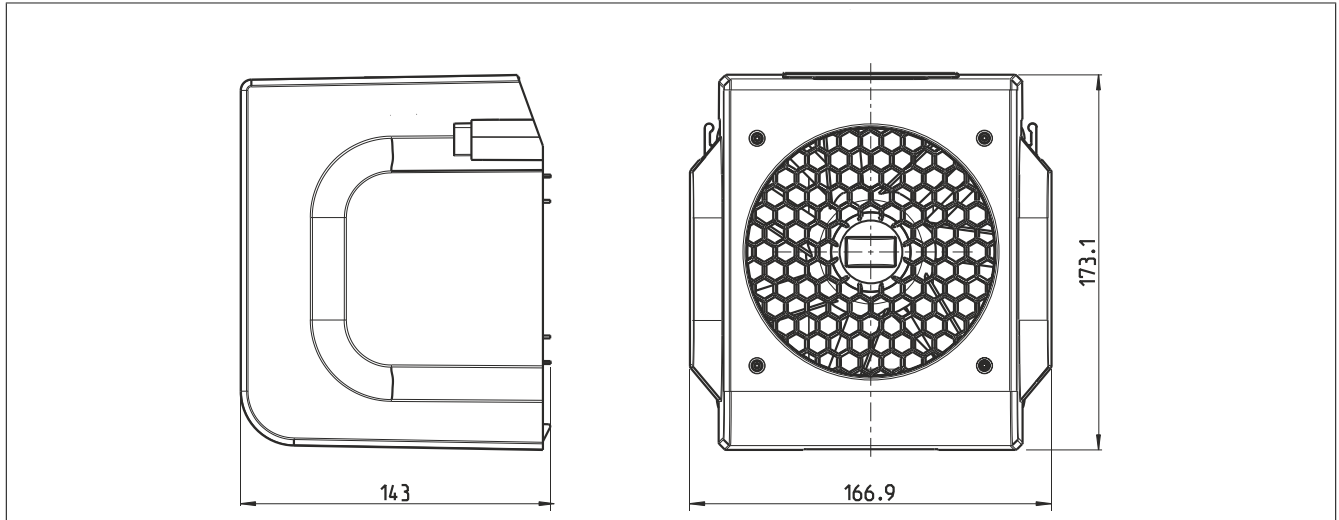

Figure 115: 8ZDFB5000000.000-0 - Dimensions

### 8.1.1.4 Blind covers / caps

#### 8.1.1.4.1 8CXC000.0000-00

##### 8.1.1.4.1.1 Order data

Order number	Short description	Figure
	<b>Accessory sets</b>	
8CXC000.0000-00	Accessory set: 1x slot cover for hybrid connector	

Table 212: 8CXC000.0000-00 - Order data

### Information:

**ACOPOSremote/ACOPOSmotor modules only comply with IP65 as set out in EN 60529 if all the unal-located connections are covered with blind covers/caps.**

##### 8.1.1.4.1.2 Technical data

Order number	8CXC000.0000-00
<b>General information</b>	
Short description	Accessory set: 1x slot cover for hybrid connector
Certifications	
CE	Yes
UL	cULus E225616 Power conversion equipment
<b>Mechanical properties</b>	
Weight	24 g

Table 213: 8CXC000.0000-00 - Technical data

### 8.1.1.4.2 X67AC0M08

#### 8.1.1.4.2.1 Order data

Order number	Short description	Figure
	<b>Threaded caps</b>	
X67AC0M08	X67 M8 threaded caps, 50 pcs.	

Table 214: X67AC0M08 - Order data

### Information:

ACOPOSremote/ACOPOSmotor modules only comply with IP65 as set out in EN 60529 if all the unal-located connections are covered with blind covers/caps.

#### 8.1.1.4.2.2 Technical data

Order number	X67AC0M08
<b>General information</b>	
Note	Package of 50 pcs.
Connection	M8
Short description	X67 M8 threaded caps, 50 pcs.
<b>Mechanical properties</b>	
Weight	0.02 kg

Table 215: X67AC0M08 - Technical data

### 8.1.1.4.3 X67AC0M12

#### 8.1.1.4.3.1 Order data

Order number	Short description	Figure
	<b>Threaded caps</b>	
X67AC0M12	X67 M12 threaded caps, 50 pcs.	

Table 216: X67AC0M12 - Order data

### Information:

ACOPOSremote/ACOPOSmotor modules only comply with IP65 as set out in EN 60529 if all the unal-located connections are covered with blind covers/caps.

#### 8.1.1.4.3.2 Technical data

Order number	X67AC0M12
<b>General information</b>	
Note	Package of 50 pcs.
Connection	M12
Short description	X67 M12 threaded caps, 50 pcs.
<b>Mechanical properties</b>	
Weight	0.03 kg

Table 217: X67AC0M12 - Technical data

## 8.2 ACOPOSmotor Compact

### 8.2.1 Accessories for ACOPOSmotor Compact

#### 8.2.1.1 Cables

##### 8.2.1.1.1 Hybrid cables

##### 8.2.1.1.1.1 Power supply cables

##### 8D1CHxxxx.11120-0 - Order data

Order number	Short description	Figure
	<b>Supply cable</b>	
8D1CH0003.11120-0	ACOPOSmotor compact power supply cable, length 3 m, 2x 2.5 mm <sup>2</sup> + 1x (4x 0.34 mm <sup>2</sup> ) + 1x (2x 0.34 mm <sup>2</sup> ) + 1x 0.34 mm <sup>2</sup> + PA pipe 2.0 mm / 1.0 mm, 1x 9-pin female hybrid connector, can be used in cable drag chains	
8D1CH0005.11120-0	ACOPOSmotor compact power supply cable, length 5 m, 2x 2.5 mm <sup>2</sup> + 1x (4x 0.34 mm <sup>2</sup> ) + 1x (2x 0.34 mm <sup>2</sup> ) + 1x 0.34 mm <sup>2</sup> + PA pipe 2.0 mm / 1.0 mm, 1x 9-pin female hybrid connector, can be used in cable drag chains	
8D1CH0010.11120-0	ACOPOSmotor compact power supply cable, length 10 m, 2x 2.5 mm <sup>2</sup> + 1x (4x 0.34 mm <sup>2</sup> ) + 1x (2x 0.34 mm <sup>2</sup> ) + 1x 0.34 mm <sup>2</sup> + PA pipe 2.0 mm / 1.0 mm, 1x 9-pin female hybrid connector, can be used in cable drag chains	
8D1CH0015.11120-0	ACOPOSmotor compact power supply cable, length 15 m, 2x 2.5 mm <sup>2</sup> + 1x (4x 0.34 mm <sup>2</sup> ) + 1x (2x 0.34 mm <sup>2</sup> ) + 1x 0.34 mm <sup>2</sup> + PA pipe 2.0 mm / 1.0 mm, 1x 9-pin female hybrid connector, can be used in cable drag chains	

Table 218: 8D1CH0003.11120-0, 8D1CH0005.11120-0, 8D1CH0010.11120-0, 8D1CH0015.11120-0 - Order data

##### 8D1CHxxxx.11120-0 - Technical data

Order number	8D1CH0003.11120-0	8D1CH0005.11120-0	8D1CH0010.11120-0	8D1CH0015.11120-0
<b>General information</b>				
Cable cross section	2x2.5 + 1x(4x0.34)St-C + 1x(2x0.34)C + 1x0.34qmm + PA pipe 2.0/1.0			
Durability	Oil resistant per DIN EN 60811-404 Halogen-free per DIN EN 60754-1 Flame-retardant per DIN EN IEC 60332-1-2 Hydrolysis resistance per DIN EN 50396 Microbial resistance per DIN EN 50396 Silicone-free / PWIS per VW PV 3.7.10			
Certification	E170315 cRUus AWM STYLE 20233 AWM I/II A/B 80°C 300 V FT1 <sup>1)</sup>			
Certifications				
CE	Yes			
UL	cULus E225616 Power conversion equipment			
cULus	In preparation			
<b>Cable construction</b>				
Outer jacket				
Material	TPU, flame-retardant, halogen-free			
Color	Orange similar to RAL 2003			
<b>Connector</b>				
Type	9-pin female hybrid connector			
Mating cycles	<500			
Contacts	9			
Additional connectors	RJ45			
Degree of protection per EN 60529	IP66/67 when connected			
<b>Electrical properties <sup>1)</sup></b>				
Nominal current	20 A (power) 0.5 A (signal)			
Operating voltage	Max. 58 VDC (power) Max. 30 VDC (signal)			
<b>Ambient conditions <sup>1)</sup></b>				
Temperature				
Moving	-30°C to +80°C (drag chain: -20°C to +60°C)			
Static	-40°C to +90°C			
<b>Mechanical properties <sup>1)</sup></b>				
Dimensions				
Length	3 m	5 m	10 m	15 m
Diameter	11.7 mm ±0.3 mm			

Table 219: 8D1CH0003.11120-0, 8D1CH0005.11120-0, 8D1CH0010.11120-0, 8D1CH0015.11120-0 - Technical data

## Accessories

Order number	8D1CH0003.11120-0	8D1CH0005.11120-0	8D1CH0010.11120-0	8D1CH0015.11120-0
Bend radius				
Single bend	≥3x cable diameter			
Moving	≥12.5x cable diameter			
Drag chain data				
Acceleration	50 m/s <sup>2</sup> (depends on the length of the travel path)			
Flex cycles	≥3,000,000			
Velocity	Max. 300 m/min			
Torsional strength	±30°/m			
Weight	0.950 kg	1.4 kg	2.60 kg	3.75 kg

Table 219: 8D1CH0003.11120-0, 8D1CH0005.11120-0, 8D1CH0010.11120-0, 8D1CH0015.11120-0 - Technical data

- 1) Values refer to the raw cable being used.

## 8.2.1.1.1.2 Power cables

## 8D1CHxxx.11110-0 - Order data

Order number	Short description	Figure
	<b>Power cable</b>	
8D1CH00X5.11110-0	ACOPOSmotor compact power cable, length 0.5 m, 1x 9-pin female hybrid connector, 1x 9-pin male hybrid connector, can be used in cable drag chains	
8D1CH0001.11110-0	ACOPOSmotor compact power cable, length 1 m, 1x 9-pin female hybrid connector, 1x 9-pin male hybrid connector, can be used in cable drag chains	
8D1CH0002.11110-0	ACOPOSmotor compact power cable, length 2 m, 1x 9-pin female hybrid connector, 1x 9-pin male hybrid connector, can be used in cable drag chains	
8D1CH0003.11110-0	ACOPOSmotor compact power cable, length 3 m, 1x 9-pin female hybrid connector, 1x 9-pin male hybrid connector, can be used in cable drag chains	
8D1CH0005.11110-0	ACOPOSmotor compact power cable, length 5 m, 1x 9-pin female hybrid connector, 1x 9-pin male hybrid connector, can be used in cable drag chains	
8D1CH0010.11110-0	ACOPOSmotor compact power cable, length 10 m, 1x 9-pin female hybrid connector, 1x 9-pin male hybrid connector, can be used in cable drag chains	
8D1CH0015.11110-0	ACOPOSmotor compact power cable, length 15 m, 1x 9-pin female hybrid connector, 1x 9-pin male hybrid connector, can be used in cable drag chains	

Table 220: 8D1CH00X5.11110-0, 8D1CH0001.11110-0, 8D1CH0002.11110-0, 8D1CH0003.11110-0, 8D1CH0005.11110-0, 8D1CH0010.11110-0, 8D1CH0015.11110-0 - Order data

## 8D1CHxxx.11110-0 - Technical data

Order number	8D1CH00X5.11110-0	8D1CH0001.11110-0	8D1CH0002.11110-0	8D1CH0003.11110-0	8D1CH0005.11110-0	8D1CH0010.11110-0	8D1CH0015.11110-0
<b>General information</b>							
Cable cross section	2x2.5 + 1x(4x0.34)St-C + 1x(2x0.34)C + 1x0.34qmm + PA pipe 2.0/1.0						
Durability	Oil resistant per DIN EN 60811-404 Halogen-free per DIN EN 60754-1 Flame-retardant per DIN EN IEC 60332-1-2 Hydrolysis resistance per DIN EN 50396 Microbial resistance per DIN EN 50396 Silicone-free / PWIS per VW PV 3.7.10						
Certification	E170315 cRUus AWM STYLE 20233 AWM I/II A/B 80°C 300 V FT1 <sup>1)</sup>						
Certifications							
CE	Yes						
UL	cULus E225616 Power conversion equipment						
cULus	In preparation						
<b>Cable construction</b>							
Outer jacket							
Material	TPU, flame-retardant, halogen-free						
Color	Orange similar to RAL 2003						
<b>Connector</b>							
Type	9-pin female hybrid connector						
Mating cycles	<500						
Contacts	9						
Additional connectors	9-pin male hybrid connector Mating cycles: <500 Contacts: 9 Degree of protection per EN 60529: IP66/67 when connected						
Degree of protection per EN 60529	IP66/67 when connected						
<b>Electrical properties <sup>1)</sup></b>							
Nominal current	20 A (power) 0.5 A (signal)						
Operating voltage	Max. 58 VDC (power) Max. 30 VDC (signal)						
<b>Ambient conditions <sup>1)</sup></b>							
Temperature							
Moving	-30°C to +80°C (drag chain: -20°C to +60°C)						
Static	-40°C to +90°C						
<b>Mechanical properties <sup>1)</sup></b>							
Dimensions							
Length	0.5 m	1 m	2 m	3 m	5 m	10 m	15 m
Diameter	11.7 mm ±0.3 mm						

Table 221: 8D1CH00X5.11110-0, 8D1CH0001.11110-0, 8D1CH0002.11110-0, 8D1CH0003.11110-0, 8D1CH0005.11110-0, 8D1CH0010.11110-0, 8D1CH0015.11110-0 - Technical data

## Accessories

Order number	8D1CH00X5. 11110-0	8D1CH0001. 11110-0	8D1CH0002. 11110-0	8D1CH0003. 11110-0	8D1CH0005. 11110-0	8D1CH0010. 11110-0	8D1CH0015. 11110-0
Bend radius							
Single bend	≥3x cable diameter						
Moving	≥12.5x cable diameter						
Drag chain data							
Acceleration	50 m/s <sup>2</sup> (depends on the length of the travel path)						
Flex cycles	≥3,000,000						
Velocity	Max. 300 m/min						
Torsional strength	±30°/m						
Weight	0.55 kg	0.65 kg	0.90 kg	1.15 kg	1.40 kg	2.75 kg	3.90 kg

Table 221: 8D1CH00X5.11110-0, 8D1CH0001.11110-0, 8D1CH0002.11110-0, 8D1CH0003.11110-0, 8D1CH0005.11110-0, 8D1CH0010.11110-0, 8D1CH0015.11110-0 - Technical data

- 1) Values refer to the raw cable being used.

## 8.2.1.1.2 M8 sensor cables

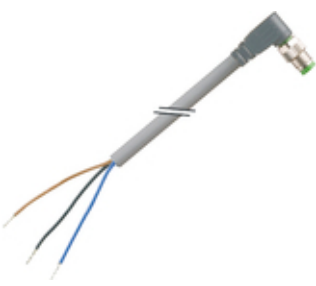
Length	Short description	
	M8 sensor cables	
2 m	X67CA0D40.0020	X67CA0D50.0020
5 m	X67CA0D40.0050	X67CA0D50.0050
10 m	X67CA0D40.0100	X67CA0D50.0100
15 m	X67CA0D40.0150	X67CA0D50.0150
20 m	X67CA0D40.0200	X67CA0D50.0200
		

Length	Tolerances for cable lengths
0 to <1 m	+2 cm
1 m to <10 m	+5 cm
10 m to xx m	+10 cm

## 8.2.1.1.2.1 Technical data

Product ID	X67CA0D40	X67CA0D50
<b>General information</b>		
Note	PVC- and silicone-free PWIS- and halogen-free	
Durability	Good chemical and oil resistance Flame-retardant Good UV and ozone resistance	
Connection	M8, 3-pin, straight	M8, 3-pin, angled
Type	Attachment cables	
Cable cross section		
AWG	3x 22 AWG	
mm <sup>2</sup>	3x 0.34 mm <sup>2</sup>	
<b>Cable construction</b>		
Cable shield	Not shielded	
Outer jacket		
Material	Polyurethane (PUR)	
Color	Gray	
Labeling	B&R X67CA0Dxx.xxxx Rev. G0 ESCHA FC <sup>1)</sup>	
Wires		
Wire insulation	Polypropylene (PP) 9Y	
Wire colors	Brown, black, blue	
Type	Uncoated copper ETP1 Fine stranded wire (42x 0.1 mm / 42x 38 AWG), class 5	
Stranding	3-wire twisted pair	
<b>Electrical properties</b>		
Nominal current	Max. 4 A / Contact at 40°C	
Operating voltage	Max. 60 V	
Degree of insulation	Category II per IEC 61076-2	
Conductor resistance	≤57 Ω/km	
Insulation resistance	≥100 MΩ	
<b>Operating conditions</b>		
Degree of protection per EN 60529		
Connector/Coupling	IP67, only when screwed in	
<b>Ambient conditions</b>		
Temperature		
Transport	-40 to 90°C	
Fixed installation	-30 to 90°C	
Flexible installation <sup>2)</sup>	-25 to 60°C	
<b>Mechanical properties</b>		
Dimensions		
Length	Various	
Diameter	4.3 mm ±0.2 mm	
Bend radius	≥10x outer diameter	
Drag chain data		
Acceleration	Max. 5 m/s <sup>2</sup>	
Flex cycles	5 million	
Velocity	Max. 3.3 m/s	

Table 222: X67CA0Dxx - Technical data

- 1) xx.xxxx: Group number and cable length  
2) In cable drag chain operation

### 8.2.1.1.2.2 X67CA0D40.xxxx

Dimensions				
Pinout				
Connector	Pin	Name	Wire colors	Open-ended
	1	Sensor/actuator power supply 24 VDC	Brown	For custom wiring
	3	GND	Blue	
	4	Input/Output x	Black	

### 8.2.1.1.2.3 X67CA0D50.xxxx

Dimensions				
Pinout				
Connector	Pin	Name	Wire colors	Open-ended
	1	Sensor/actuator power supply 24 VDC	Brown	For custom wiring
	3	GND	Blue	
	4	Input/Output x	Black	

## 9 Standards and certifications

### 9.1 International and national certifications

Products and services from B&R comply with applicable regulations, directives and standards. These are national, European and international regulations, mainly from organizations such as ISO, IEC and CENELEC. We are committed to ensuring the reliability of our products in industrial environments.

#### Information:

Certifications that apply to a particular module are available at the following places:

- The data sheet's technical data under "General information → Certifications"
- At [www.br-automation.com](http://www.br-automation.com) under "Products" in the "General information → Certifications" area of the technical data
- On the side of the module housing

#### 9.1.1 Marks

Mark	Explanation	Region
	CE marking	Europe (EU)
	Functional safety (CE)	Europe (EU)
	Underwriters Laboratories Inc. (UL)	Canada USA
	Underwriters Laboratories Inc. (UL)	Canada USA
	Korean Conformity (KC)	Korea
	UKCA	Great Britain (England, Scotland, Wales)



**Machinery Directive 2006/42/EC****Standard  
safety technology**

No mark

**Functional safety**

  
**open SAFETY**
  
 certified product

In accordance with the Machinery Directive, safety technology products are designed, developed, tested and labeled for special applications providing protection to machinery and personnel.

Certification of these products is performed exclusively in cooperation with EU-authorized bodies (notified bodies).

**Europe (EU)****Europe (EU)**

Applicable standards from this directive:

IEC 61508-1	Functional safety of electrical/electronic/programmable electronic safety-related systems - Part 1: General requirements
IEC 61508-2	Functional safety of electrical / electronic / programmable electronic safety-related systems - Part 2: Requirements for electrical/electronic/programmable electronic safety-related systems
IEC 61508-3	Functional safety of electrical / electronic / programmable electronic safety-related systems - Part 3: Software requirements
IEC 61508-4	Functional safety of electrical/electronic/programmable electronic safety-related systems - Part 4: Definitions and abbreviations
EN 61800-5-2	Adjustable speed electrical power drive systems - Part 5-2: Safety requirements - Functional
EN 62061	Safety of machinery - Functional safety of safety-related electrical, electronic and programmable electronic control systems
EN ISO 13849-1	Safety of machinery - Safety-related parts of control systems - Part 1: General principles for design

The declaration of conformity, certificates and additional safety-related information are available for download on the B&R website. For information about the versions of applicable standards, see the declaration of conformity.

**Declaration of conformity**

[Website > Downloads > Certificates > Declarations of conformity > ACOPOSremote > Declaration FS Servos ACOPOSremote](#)  
[Website > Downloads > Certificates > Declarations of conformity > ACOPOSmotor > Declaration FS Servos ACOPOSmotor](#)  
[Website > Downloads > Certificates > Declarations of conformity > Declaration FS Servos ACOPOSmotor Compact](#)

**Certificates**

[Website > Downloads > Certificates > Safety technology > ACOPOSremote > TÜV certificate - Function "Safe pulse disabling" for ACOPOSremote](#)  
[Website > Downloads > Certificates > Safety technology > ACOPOSmotor > TÜV certificate - Function "Safe pulse disabling" for ACOPOSmotor](#)  
[Website > Downloads > Certificates > Safety technology > ACOPOSmotor Compact > TÜV certificate - Functional safety ACOPOSmotor Compact](#)  
[Website > Downloads > Certificates > Safety technology > ACOPOSmotor > TÜV certificate - Functional safety - ACOPOSmotor SafeMOTION EnDat 2.2](#)

**SafeMOTION user's manual**

[Website > Downloads > Safety technology > ACOPOSmotor > SafeMOTION user's manual](#)

### 9.1.2.1 Requirements for immunity to disturbances

- EN 61800-3 requirements apply.
- For all modules that have certified safety functions, stricter requirements apply for section "High-frequency disturbances" per EN 61800-5-2.

Immunity	Testing performed per	Requirements per
Electrostatic discharge (ESD)	EN 61000-4-2	EN 61800-3: Product standard - Adjustable speed electrical power drive systems EN 61800-5-2: Product standard - Adjustable speed electrical power drive systems
High-frequency electromagnetic fields (HF field)	EN 61000-4-3	EN 61800-3: Product standard - Adjustable speed electrical power drive systems EN 61800-5-2: Product standard - Adjustable speed electrical power drive systems
High-speed transient electrical disturbances (Burst)	EN 61000-4-4	EN 61800-3: Product standard - Adjustable speed electrical power drive systems EN 61800-5-2: Product standard - Adjustable speed electrical power drive systems
Surge voltages (Surge)	EN 61000-4-5	EN 61800-3: Product standard - Adjustable speed electrical power drive systems EN 61800-5-2: Product standard - Adjustable speed electrical power drive systems
Conducted disturbances	EN 61000-4-6	EN 61800-3: Product standard - Adjustable speed electrical power drive systems EN 61800-5-2: Product standard - Adjustable speed electrical power drive systems

### Evaluation criteria for performance

Criteria (PC)	During test	After test
<b>A</b>	The system shall continue to operate as intended. No loss of function or performance.	The system shall continue to operate as intended.
<b>B</b>	Degradation of performance accepted. The operating mode is not permitted to change. Irreversible loss of stored data is not permitted.	The system shall continue to operate as intended. Temporary degradation of performance must be self-recoverable.
<b>C</b>	Loss of functions accepted, but no destruction of hardware or software (program or data).	The system shall continue to operate as intended automatically, after manual restart or power off / power on.
<b>FS</b>	Functional safety - Behavior of test object per EN 61800-5-2, item 6.2.5.3	

### 9.1.2.1.1 High-frequency interference

The following limit values are applicable for industrial environments (category C3).

#### Electrostatic discharge (ESD)

Testing performed per EN 61000-4-2	Requirements per EN 61800-3	PC	Requirements per EN 61800-5-2 <sup>1)</sup> Increased immunity to interference	PC
Contact discharge (CD) on conductive accessible parts	±4 kV	B	±6 kV	FS
Air discharge (AD) on insulating accessible parts	±8 kV		±15 kV	

1) The total number of discharges depends on the required safety integrity level (SIL) and listed in EN 61800-5-2.

#### High-frequency electromagnetic fields (HF field)

Testing performed per EN 61000-4-3	Requirements per EN 61800-3	PC	Requirements per EN 61800-5-2 <sup>1)</sup> Increased immunity to interference	PC
Housing, completely wired	80 MHz to 1 GHz 10 V/m 80% amplitude modulation (1 kHz)	A	80 MHz to 1 GHz 20 V/m 80% amplitude modulation (1 kHz)	FS
	1.4 GHz to 2 GHz 3 V/m 80% amplitude modulation (1 kHz)		1.4 GHz to 2 GHz 10 V/m 80% amplitude modulation (1 kHz)	
	2 GHz to 2.7 GHz 1 V/m 80% amplitude modulation (1 kHz)		2 GHz to 6 GHz 3 V/m 80% amplitude modulation (1 kHz)	

#### High-speed transient electrical disturbances (Burst)

Testing performed per EN 61000-4-4	Requirements per EN 61800-3	PC	Requirements per EN 61800-5-2 <sup>1)</sup> Increased immunity to interference	PC
Power supply connections	±2 kV 1 min Direct coupling	B	±4 kV Direct coupling	FS
Connections for process measurement, open-loop and closed-loop process control	±2 kV 1 min		±4 kV	
Signal interfaces	±1 kV 1 min		±2 kV	

1) The duration of the effect depends on the required safety integrity level (SIL) and listed in EN 61800-5-2.

#### Surge voltages (Surge)

Testing performed per EN 61000-4-5	Requirements per EN 61800-3	PC	Requirements per EN 61800-5-2 <sup>1)</sup> Increased immunity to interference	PC
Power supply connections	±1 kV DM Symmetrical	B	±2 kV DM Symmetrical	FS
	±2 kV CM Asymmetrical		±4 kV CM Asymmetrical	
Connections for process measurement, open-loop and closed-loop process control	±1 kV CM Asymmetrical		±2 kV CM Asymmetrical	
Signal interfaces	---	±0.5 kV CM Asymmetrical		

1) The number of pulses depends on the required safety integrity level (SIL) and listed in EN 61800-5-2.

#### Conducted disturbances

Testing performed per EN 61000-4-6	Requirements per EN 61800-3	PC	Requirements per EN 61800-5-2 <sup>1)</sup> Increased immunity to interference	PC
Power supply connections	150 kHz to 80 MHz	A	150 kHz to 80 MHz	FS
Connections for process measurement, open-loop and closed-loop process control	10 V 80% amplitude modulation (1 kHz)		20 V 80% amplitude modulation (1 kHz)	
Signal interfaces				

### 9.1.2.2 Emission requirements

Phenomenon	Testing performed per	Limit values per
Radiated emissions	EN 55011	EN 61800-3: Product standard - Adjustable speed electrical power drive systems

The following limit values are applicable for industrial environments (category C3).

## Radiated emissions

Testing performed per EN 55011	Limit values per EN 61800-3	
	Frequency band	Quasi-peak value
Electric field / Measured from 10 m 30 MHz to 1 GHz	30 MHz to 230 MHz	50 dB (µV/m)
	230 MHz to 1 GHz	60 dB (µV/m)

### 9.1.2.3 Mechanical conditions

Test	Testing performed per	Requirements per
Oscillation (sinusoidal) / 8CVI, 8DI, 8D1 operation	EN 60068-2-6	EN 61800-2: Product standard - Adjustable speed electrical power drive systems EN 60721-3-3 / class 3M7
Vibration (sinusoidal) / 8CVE operation	EN 60068-2-6	EN 61800-2: Product standard - Adjustable speed electrical power drive systems EN 60721-3-3 / class 3M4
Vibration (sinusoidal) / Transport (packaged)	EN 60068-2-6	EN 61800-2: Product standard - Adjustable speed electrical power drive systems EN 60721-3-2 / Class 2M1
Free fall / Transport (packaged)	EN 60068-2-31 <sup>1)</sup>	EN 61800-2: Product standard - Adjustable speed electrical power drive systems EN ISO 4180

1) Replacement for EN 60068-2-32

### Oscillation (sinusoidal) / 8CVI, 8DI, 8D1 operation

Testing performed per EN 60068-2-6	Requirements per EN 61800-2 and EN 60721-3-3 / class 3M7	
	Frequency band	Amplitude
Vibration (sinusoidal) / Operation	2 to 9 Hz	3 mm
	9 to 200 Hz	Acceleration 3 g <sup>1)</sup>

1) 1 g = 10 m/s<sup>2</sup>

### Vibration (sinusoidal) / 8CVE operation

Testing performed per EN 60068-2-6	Requirements per EN 61800-2 and EN 60721-3-3 / class 3M4	
	Frequency	Amplitude
Vibration (sinusoidal) / Operation	2 to 9 Hz	3 mm
	9 to 200 Hz	Acceleration 1 g <sup>1)</sup>

1) 1 g = 10 m/s<sup>2</sup>

### Vibration (sinusoidal) / Transport (packaged)

Testing performed per EN 60068-2-6	Requirements per EN 61800-2 and EN 60721-3-2 / class 2M1	
	Frequency	Amplitude
Vibration (sinusoidal) / Transport (packaged) <sup>1)</sup>	2 to 9 Hz	3.5 mm
	9 to 200 Hz	Acceleration 1 g <sup>2)</sup>
	200 to 500 Hz	Acceleration 1.5 g <sup>2)</sup>

1) The values in Oscillation (sinusoidal) / 8CVI, 8DI, 8D1 operation or Vibration (sinusoidal) / 8CVE operation apply to modules that are not in their original packaging.

2) 1 g = 10 m/s<sup>2</sup>

### Free fall / Transport (packaged)

Testing performed per EN 60068-2-31	Requirements per EN 60721-3-2 / class 2M1 and EN ISO 4180	
	Weight	Height <sup>1)</sup>
Free fall / Transport (packaged)	<10 kg	0.8 m
	10 to 40 kg	0.6 m
	40 to 100 kg	0.25 m

1) Height per EN ISO 4180.

### 9.1.2.4 Climate conditions

Test	Testing performed per	Requirements per
Operation	---	EN 61800-2: Product standard - Adjustable speed electrical power drive systems EN 60721-3-3 / class 3K3
Storage	---	EN 61800-2: Product standard - Adjustable speed electrical power drive systems EN 60721-3-1 / class 1K4 / class 1K3
Transport	---	EN 61800-2: Product standard - Adjustable speed electrical power drive systems EN 60721-3-2 / class 2K3

### Operation

	Requirements per EN 60721-3-3 / class 3K3
Ambient temperature during operation	5 to 40°C
Relative humidity during operation	5 - 85%, non-condensing

### Storage

	Requirements per EN 60721-3-1 / class 1K4	Requirements per EN 60721-3-1 / class 1K3
Storage temperature	-25 to 55°C	---
Relative humidity during storage	---	5 to 95%, non-condensing

### Transport

	Requirements per EN 60721-3-2 / class 2K3
Transport temperature	-25 to 70°C
Relative humidity during transport	Max. 95% at 40°C

### 9.1.2.5 Electrical safety

#### Overvoltage category

Requirement per EN 61800-2	Explanation
Overvoltage category III	Equipment supplied from the mains power supply and permanently connected in fixed installations (including and downstream of the main distribution board).

#### Pollution degree

Requirement per EN 61800-2	Explanation
Pollution degree 2	Only non-conductive pollution usually occurs; however, temporary conductivity due to condensation must occasionally be expected when the module is out of service.

#### Degrees of protection provided by enclosures (IP code)

Requirement	Explanation of code numbers per EN 60529	Explanation for the protection of equipment	Explanation for the protection of personnel
IP 65	First number IP6x	Dust-proof.	Protected against touching dangerous parts with fingers.
	Second number IP x5	Protection against water jets (nozzle) from any angle.	---

### 9.1.3 UL / CSA - ACOPOSremote / ACOPOSmotor (8DI)



#### Underwriters Laboratories (UL)

Products with this mark are tested by Underwriters Laboratories and listed as "power conversion equipment" in category NMMS (power conversion equipment) with file number E225616.

The mark is valid for the USA and Canada and facilitates the certification of your machines and systems in this economic area.

#### Standards applied:

ACOPOSremote: UL508c	Power conversion equipment
ACOPOSmotor: UL 61800-5-1	Standard for adjustable speed electrical power drive systems
CSA-C22.2 No. 274	Adjustable speed drives



#### Certificate

[Website > Downloads > Certificates > UL > ACOPOSremote > E225616 UL certificate of compliance ACOPOSremote](#)



#### Certificate

[Website > Downloads > Certificates > UL > ACOPOSmotor > E225616 UL certificate of compliance ACOPOSmotor](#)

### 9.1.4 UL / CSA - ACOPOSmotor Compact (8D1)



**POWER  
CONVERSION  
EQUIPMENT  
E225616**

#### Underwriters Laboratories (UL)

Products with this mark are tested by Underwriters Laboratories and listed with the file number E225616.

The mark is valid for the **USA and Canada** and simplifies the certification of your machines and systems in this economic area.

Standards applied:

UL 61800-5-1  
CSA-C22.2 No. 274

Standard for adjustable speed electrical power drive systems  
Adjustable speed drives



#### Certificate

[Website > Downloads > Certificates > UL > ACOPOSmotor > E225616 UL certificate of compliance ACOPOSmotor Compact](#)

### CONDITIONS OF ACCEPTABILITY for 8D1

For use only in complete equipment where the acceptability of the combination is determined by UL LLC.

1. These devices shall not to be directly connected to the supply mains of OVC III. Instead they are intended for connection to UL certified dc sources. The power supply shall provide galvanic isolation from mains, its maximum ampacity shall not exceed 60A at 58VDC. The devices shall be protected by supplementary or a branch circuit type dc fuse or circuit breaker with maximum rating not exceeding 35A. This supplementary fuse or circuit breaker are not necessary for 8B0C0320Hx00.B00 or 80PS080X3.
2. Enclosure Type rating 1

### 9.1.5 KC



#### Korean Conformity (KC)

Products with this marking have been tested by an accredited testing laboratory and approved for import to the Korean market (based on EU compliance).



#### Certificate

[Website > Downloads > Certificates > KC > ACOPOSremote > ACOPOSremote KC certificates](#)

### 9.1.6 UKCA



#### UK Conformity Assessed (UKCA)

All directives applicable to the respective product and their relevant standards are met. Products with this marking are permitted to be imported into Great Britain (England, Wales, Scotland).

Certification of these products is carried out exclusively in cooperation with accredited testing laboratories.

The corresponding UK declaration of conformity is available for download on the B&R website. For information about the editions of applicable standards, see the UK declaration of conformity.



#### UK Declaration of Conformity

[Website > Downloads > Declarations of conformity > ACOPOSremote](#)  
[Website > Downloads > Declarations of conformity > ACOPOSmotor](#)  
[Website > Downloads > Declarations of conformity > ACOPOSmotor Compact](#)

### 9.1.6.1 Supply of machinery (safety) regulations

#### Supply of machinery (safety) regulations 2008

**Standard  
safety technology**

No mark

**Functional safety**

**open**   
**SAFETY**  
certified product

In accordance with the "Supply of machinery (safety) regulations 2008", safety technology products are designed, developed, tested and labeled for special applications providing protection to machinery and personnel.

Certification of these products is carried out exclusively in cooperation with UK Approved Bodies.

#### UK (England, Scotland, Wales)

Standards applied from these UK laws:

IEC 61508-1	Functional safety of electrical/electronic/programmable electronic safety-related systems - Part 1: General requirements
IEC 61508-2	Functional safety of electrical / electronic / programmable electronic safety-related systems - Part 2: Requirements for electrical/electronic/programmable electronic safety-related systems
IEC 61508-3	Functional safety of electrical / electronic / programmable electronic safety-related systems - Part 3: Software requirements
IEC 61508-4	Functional safety of electrical/electronic/programmable electronic safety-related systems - Part 4: Definitions and abbreviations
EN 61800-5-2	Adjustable speed electrical power drive systems - Part 5-2: Safety requirements - Functional
EN 62061	Safety of machinery - Functional safety of safety-related electrical, electronic and programmable electronic control systems
EN ISO 13849-1	Safety of machinery - Safety-related parts of control systems - Part 1: General principles for design

The UK declaration of conformity, certificates and additional safety-related information are available for download on the B&R website. For information about the editions of applicable standards, see the UK declaration of conformity.



#### UK Declaration of Conformity

[Website > Downloads > Declarations of conformity > ACOPOSremote](#)  
[Website > Downloads > Declarations of conformity > ACOPOSmotor](#)  
[Website > Downloads > Declarations of conformity > ACOPOSmotor Compact](#)



#### Certificates

[Website > Downloads > Certificates > Safety technology > ACOPOSremote > TÜV certificate - Function "Safe pulse disabling" for ACOPOSremote](#)  
[Website > Downloads > Certificates > Safety technology > ACOPOSmotor > TÜV certificate - Function "Safe pulse disabling" for ACOPOSmotor](#)  
[Website > Downloads > Certificates > Safety technology > ACOPOSmotor Compact > TÜV certificate - Functional safety ACOPOSmotor Compact](#)  
[Website > Downloads > Certificates > Safety technology > ACOPOSmotor > TÜV certificate - Functional safety - ACOPOSmotor SafeMOTION EnDat 2.2](#)



#### SafeMOTION user's manual

[Website > Downloads > Safety technology > ACOPOSmotor > SafeMOTION user's manual](#)

## 9.2 Standards and definitions for safety technology

### Stop functions per EN 60204-1 (Electrical equipment of machines, Part 1: General requirements)

There are three categories of stop functions:

Category	Description
0	Stopping by immediate removal of power to the machine actuators (i.e. an uncontrolled stop).
1	A controlled stop with power left available to the machine actuators to allow for stopping. Power is only interrupted when standstill is achieved.
2	A controlled stop with power left available to the machine actuators.

Table 223: Overview of stop function categories

The necessary stop functions must be determined based on a risk assessment of the machine. Category 0 and category 1 stop functions must be functional regardless of operating mode. A category 0 stop must have priority. Stop functions must have priority over assigned start functions. Resetting the stop function is not permitted to trigger a dangerous state.

### Emergency stops per IEC 60204-1:2006 (Electrical equipment of machines, Part 1: General requirements)

In addition to the requirements for stop functions, the emergency stop function has the following requirements:

- It shall override all other functions and operations in all operating modes.
- Power to the machine actuators that can cause a hazardous situation shall be removed as quickly as possible without creating other hazards.
- A reset is not permitted to initiate a restart.

Emergency stops must be category 0 or category 1 stop functions. The necessary stop function must be determined based on a risk assessment of the machine.

### Performance levels (PL) per EN ISO 13849-1 (Safety of machinery - Safety-related parts of control systems, Part 1: General principles for design)

The safety-related parts of control systems must meet one or more of the requirements for five defined performance levels. These performance levels define the required behavior of safety-related controller parts with regard to their resistance to errors.

Performance level (per EN ISO 13849-1)	Safety integrity level - SIL (per IEC 61508-2)	Short description	System behavior
a	---	Safety-related components must be designed and built in such a way that they can meet the expected operational requirements (no specific safety measures are implemented).	<b>Caution!</b> The occurrence of a fault can result in the loss of the safety function.
b	1	Safety-related components must be designed and built in such a way that only reliable components and safety principles are used (e.g. preventing short circuits by using sufficient distances, reducing the probability of errors by using oversized components, defining the failure route, idle current principle).	<b>Caution!</b> The occurrence of a fault can result in the loss of the safety function.
c	1	Safety-related components must be designed so that their safety functions are checked at suitable intervals by the machine control system (e.g. automatic or manual check during startup).	<b>Caution!</b> An error between checks can result in the loss of the safety function. The loss of the safety function is detected during the check.
d	2	Safety-related parts shall be designed so that a single fault does not result in the loss of the safety function. Individual errors should – if possible – be detected the next time (or before) the safety function is required.	<b>Caution!</b> The safety function is always retained when a fault occurs. Some but not all errors are detected. An accumulation of undetected errors can result in loss of the safety function.
e	3	Safety-related parts shall be designed so that a single fault does not result in the loss of the safety function. Individual errors must be detected the next time (or before) the safety function is required. If this type of detection is not possible, an accumulation of faults is not permitted to result in the loss of the safety function.	<b>Information:</b> The safety function is always retained when a fault occurs. The faults are detected in time to prevent loss of the safety function.

Table 224: Overview of performance levels (PL)

A suitable performance level must be selected separately for each drive system (or for each axis) based on a risk assessment. This risk assessment is a part of the total risk assessment for the machine.

The following risk graph (per EN ISO 13849-1, appendix A) provides a simplified procedure for risk assessment:

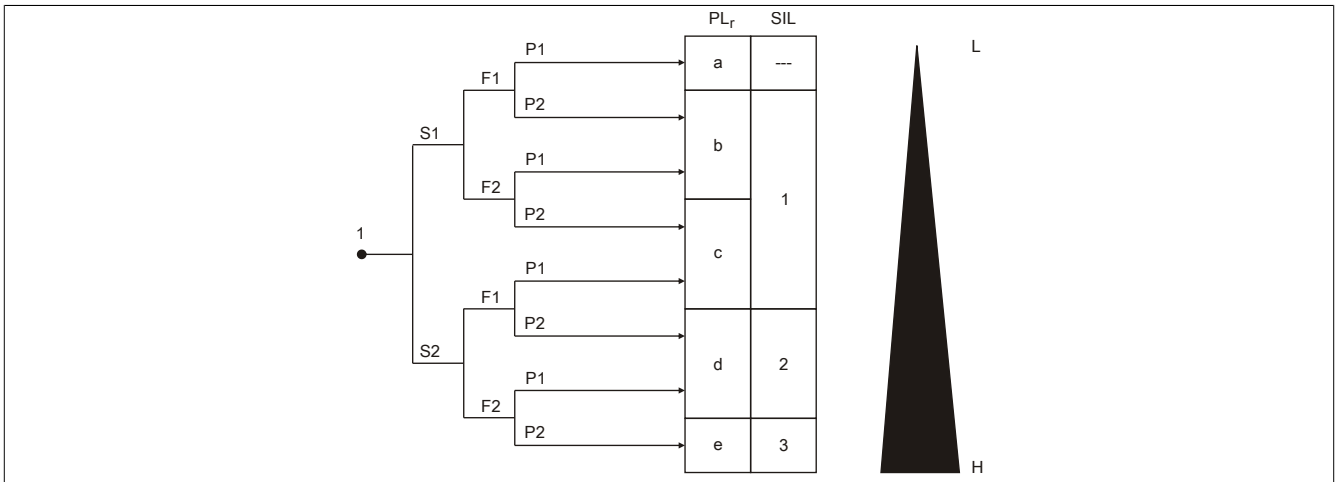

Figure 116: Risk diagram for determining the PL<sub>r</sub> for each safety function per EN ISO 13849-1, appendix A

**Legend**

- 1 Starting point for assessing the impact on risk reduction
- L Low contribution to risk reduction
- H High contribution to risk reduction
- PL<sub>r</sub> Required performance level
- SIL Safety Integrity Level per IEC 61508-2

**Risk parameters**

- S Severity of injury
- S1 Slight (normally reversible injury)
- S2 Serious (normally irreversible injury or death)
- F Frequency and/or duration of the exposure to the hazard
- F1 Seldom to less often and/or exposure time is short.
- F2 Frequent to continuous and/or exposure time is long.
- P Possibility of avoiding hazard or limiting harm
- P1 Possible under specific conditions
- P2 Scarcely possible

The performance level to be used is determined by starting at the specified starting point and taking the risk parameters S, F and P into account.

# 10 Disposal

## Separation of materials

To ensure that devices can be recycled in an environmentally friendly manner, it is necessary to separate out the different materials. Disposal must be carried out in accordance with applicable legal regulations.

Component	Disposal	Note
Motors	Electronic recycling	A magnetized rotor is not permitted to be transported or delivered outside the stator under any circumstances!
Gearbox (without oil)	Metal waste	
Waste oil (gearbox)	Special waste	
Coolant	Special waste	For liquid-cooled motors only. Consists of water / oil with additives.
Modules, cables	Electronic recycling	
Batteries	Special waste	Danger of fire: Do not store batteries together with conductive materials during disposal.
Cardboard/Paper packaging	Paper/Cardboard recycling	

## 10.1 Safety

### 10.1.1 Protective equipment

Always wear suitable safety clothing and equipment for your personal protection.

### 10.1.2 Rotor with rare earth magnets

In B&R motors, rotors are installed with rare earth magnets with high magnetic energy densities.

#### Warning!

**Personal injury and damage to property due to rare earth magnets!**

**The motors are not permitted to be disassembled into individual parts.**

**A magnetized rotor is not permitted to be transported or delivered outside the stator under any circumstances!**

- Due to the surrounding magnetic fields, the functionality of a pacemaker can be impaired in such a way that it can lead to bodily harm or even death of the carrier.
- The surrounding magnetic fields can affect or destroy electronic and mechanical measuring instruments.
- The strong magnetic attractive force can lead to uncontrolled movements of the magnet or the attraction of other objects. Personal injury due to impacts or trapping is possible. If magnets are splintered during collision, personal injury cannot be ruled out.
- In potentially explosive atmospheres, a spark generated by magnets can lead to serious explosions and cause personal injury and damage to property.

# Appendix A ACOPOSmotor 8DI modules - Derating specifications

## A.1 Continuous torque depending on ambient temperature $T_u$

### A.1.1 ACOPOSmotor modules

**8DI33e.ffggghi00-1**

In preparation

**8DI34e.ffggghi00-1**

In preparation

**8DI44e.ffggghi00-1**

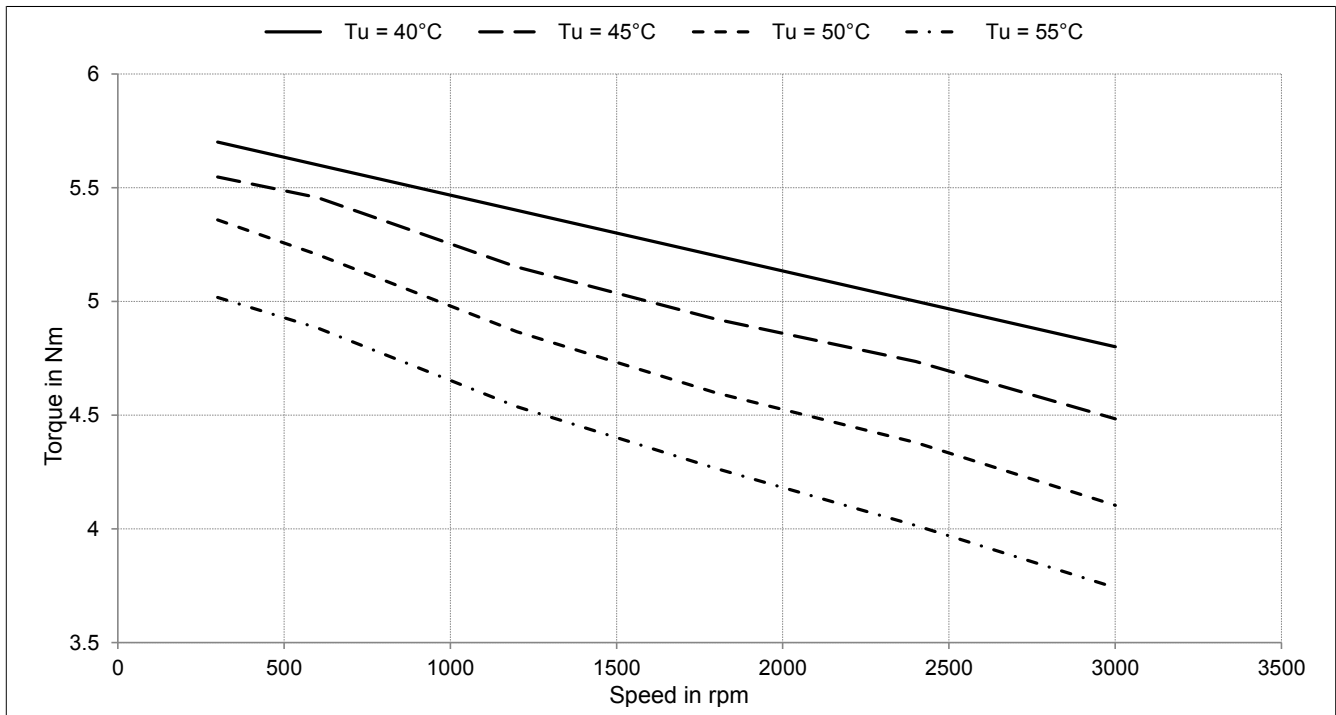

Figure 117: 8DI44e.ffggghi00-1

## 8DI44e.ffggghi00-1 with optional fan kit 8ZDFB4000000.000-0

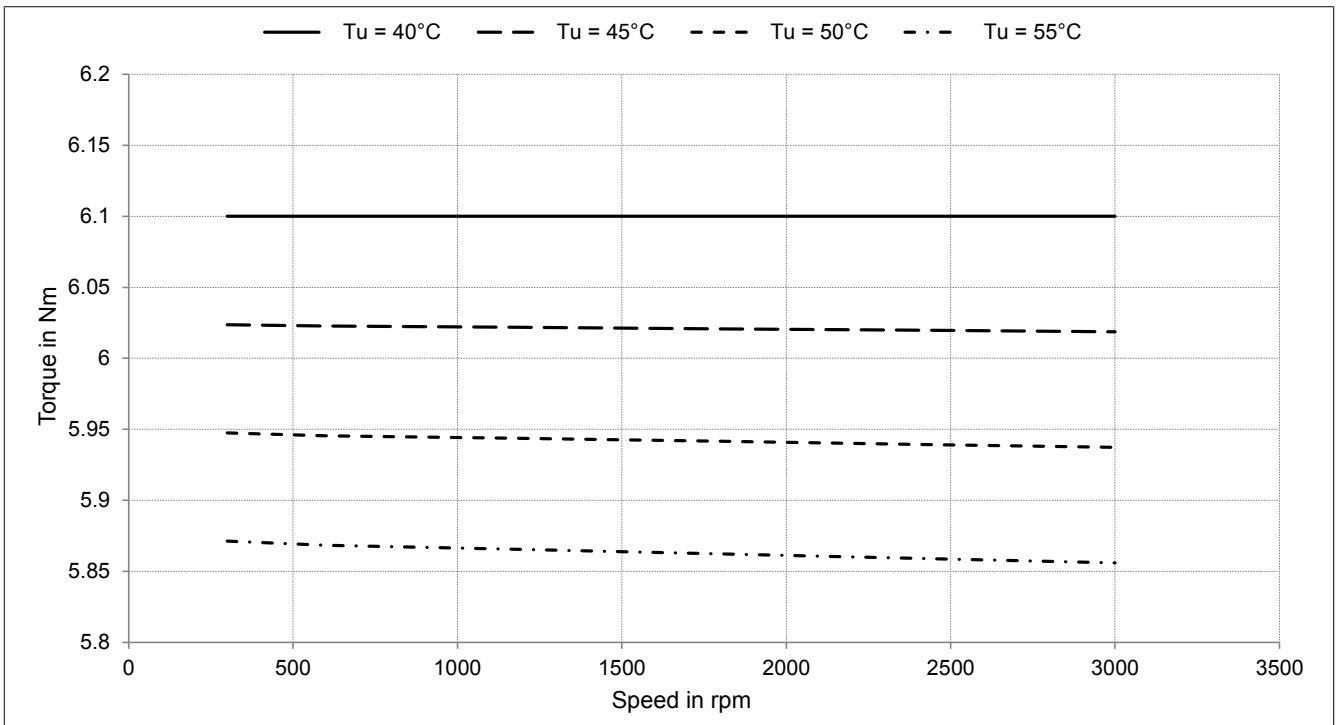

Figure 118: 8DI44e.ffggghi00-1 with optional fan kit 8ZDFB4000000.000-0

## 8DI45e.ffggghi00-1

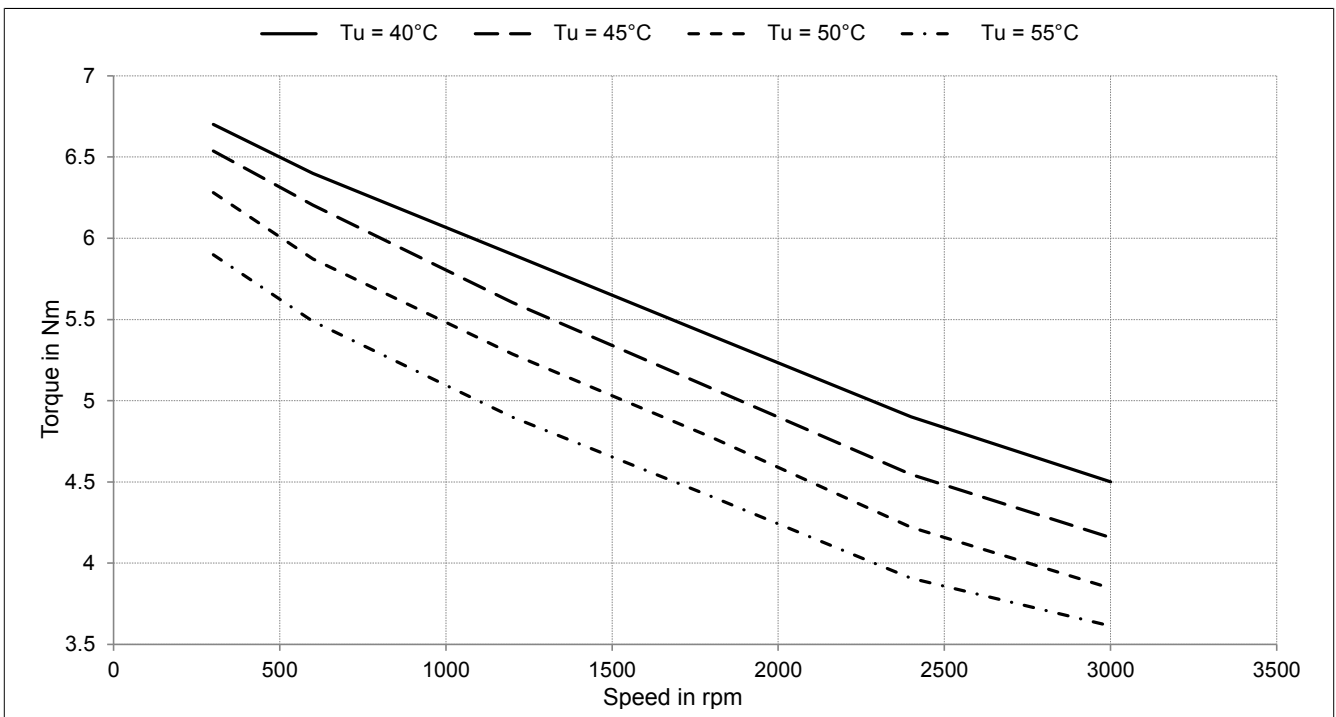

Figure 119: 8DI45e.ffggghi00-1

**8DI45e.ffggghi00-1 with optional fan kit 8ZDFB4000000.000-0**

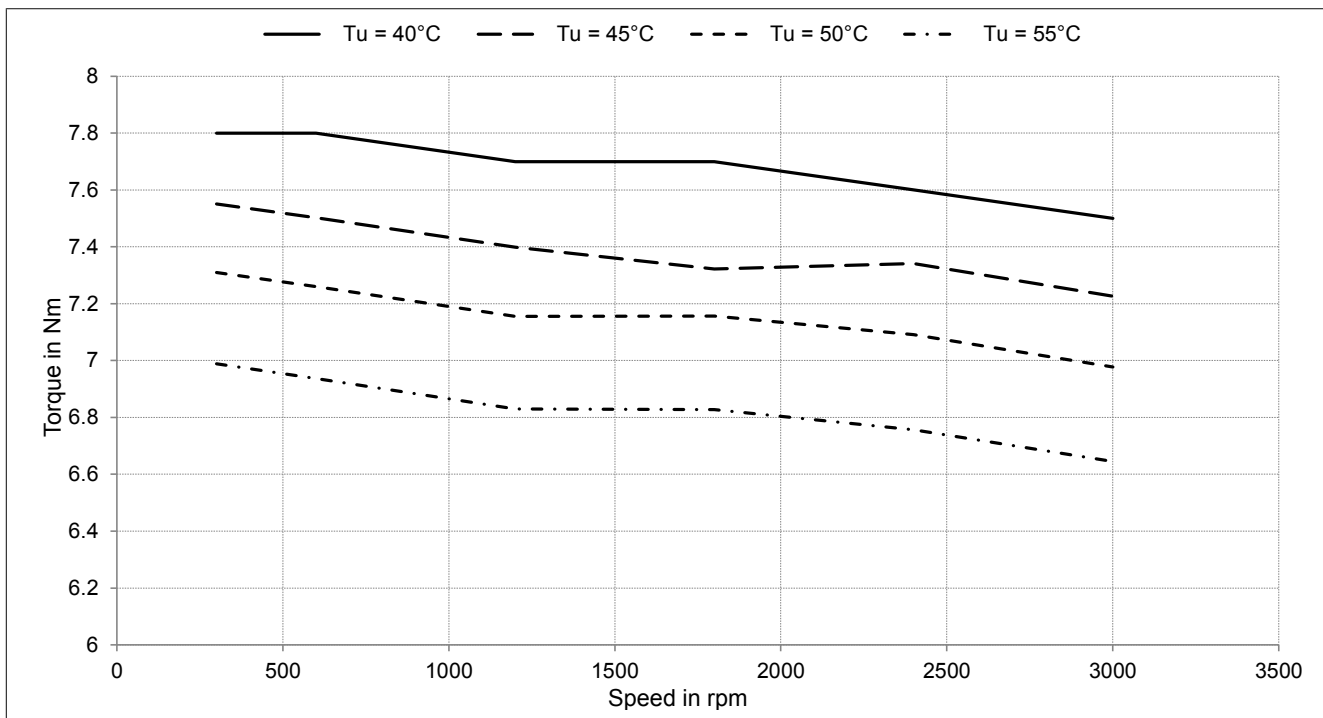

Figure 120: 8DI45e.ffggghi00-1 with optional fan kit 8ZDFB4000000.000-0

**8DI46e.ffggghi00-1**

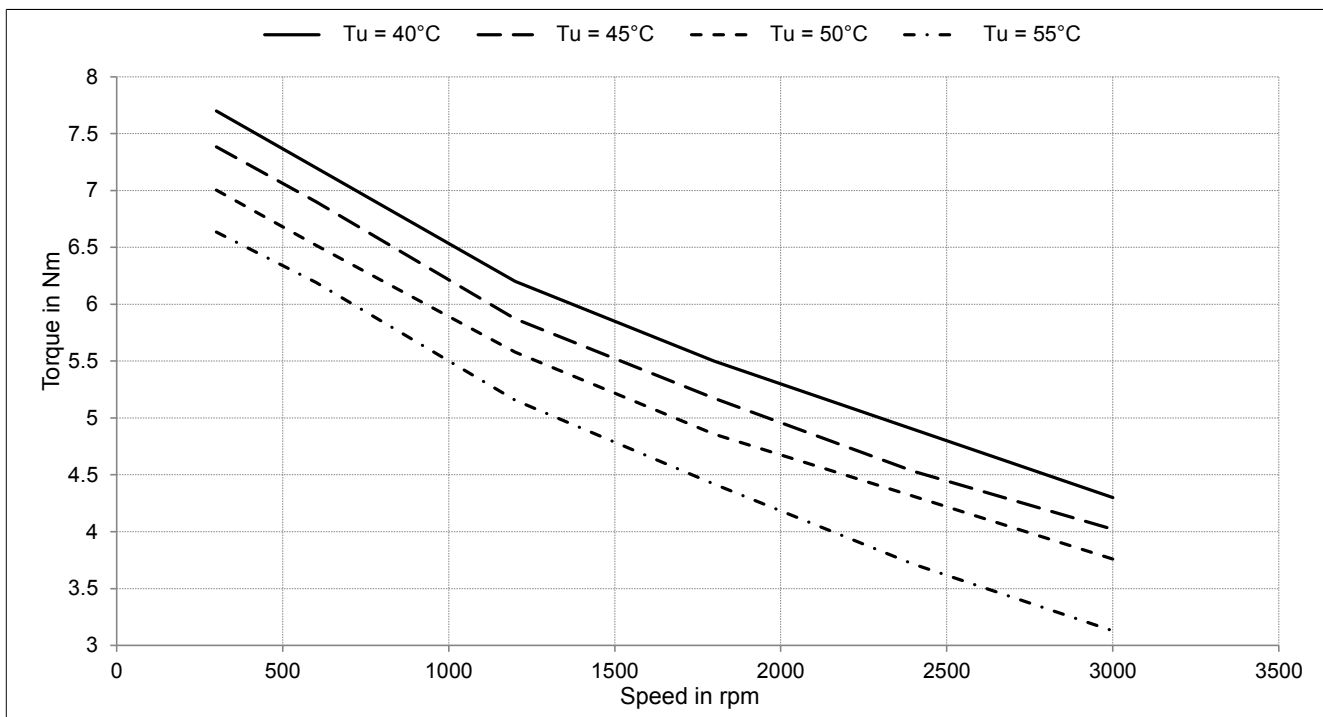

Figure 121: 8DI46e.ffggghi00-1

## 8DI46e.ffggghi00-1 with optional fan kit 8ZDFB4000000.000-0

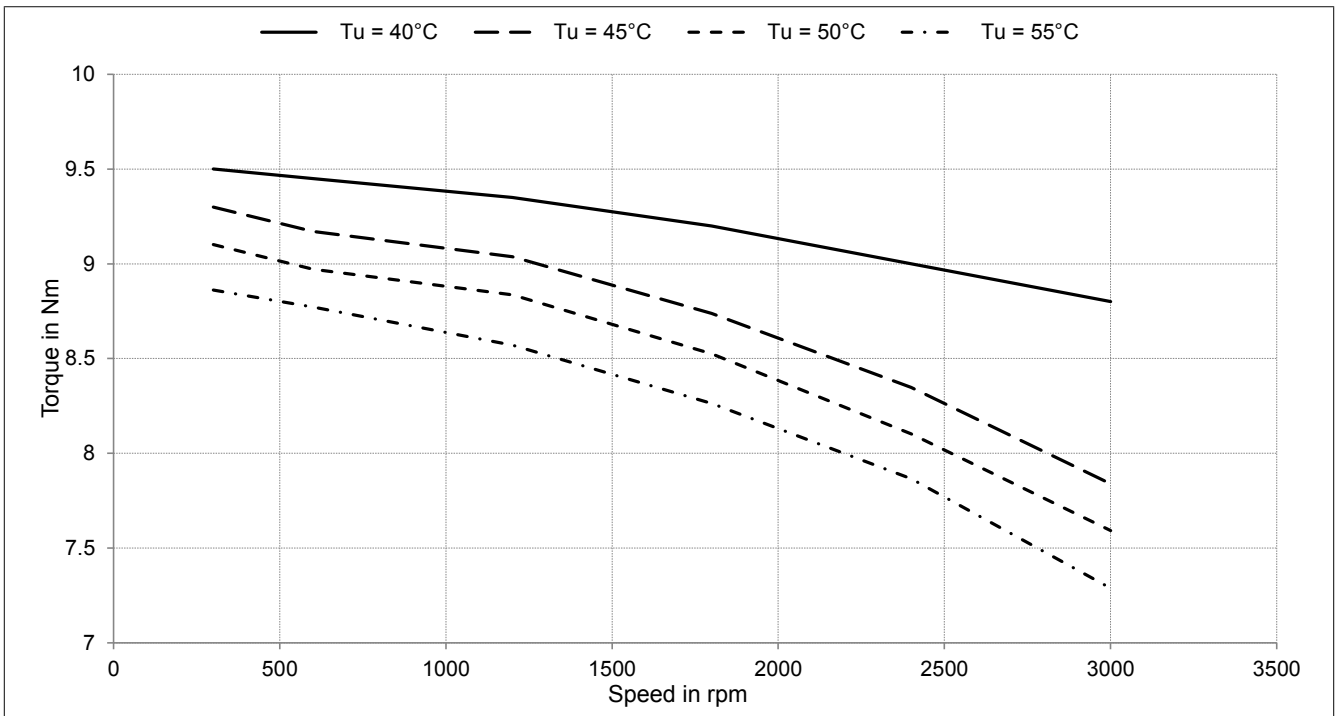

Figure 122: 8DI46e.ffggghi00-1 with optional fan kit 8ZDFB4000000.000-0

## 8DI54e.ffggghi00-1

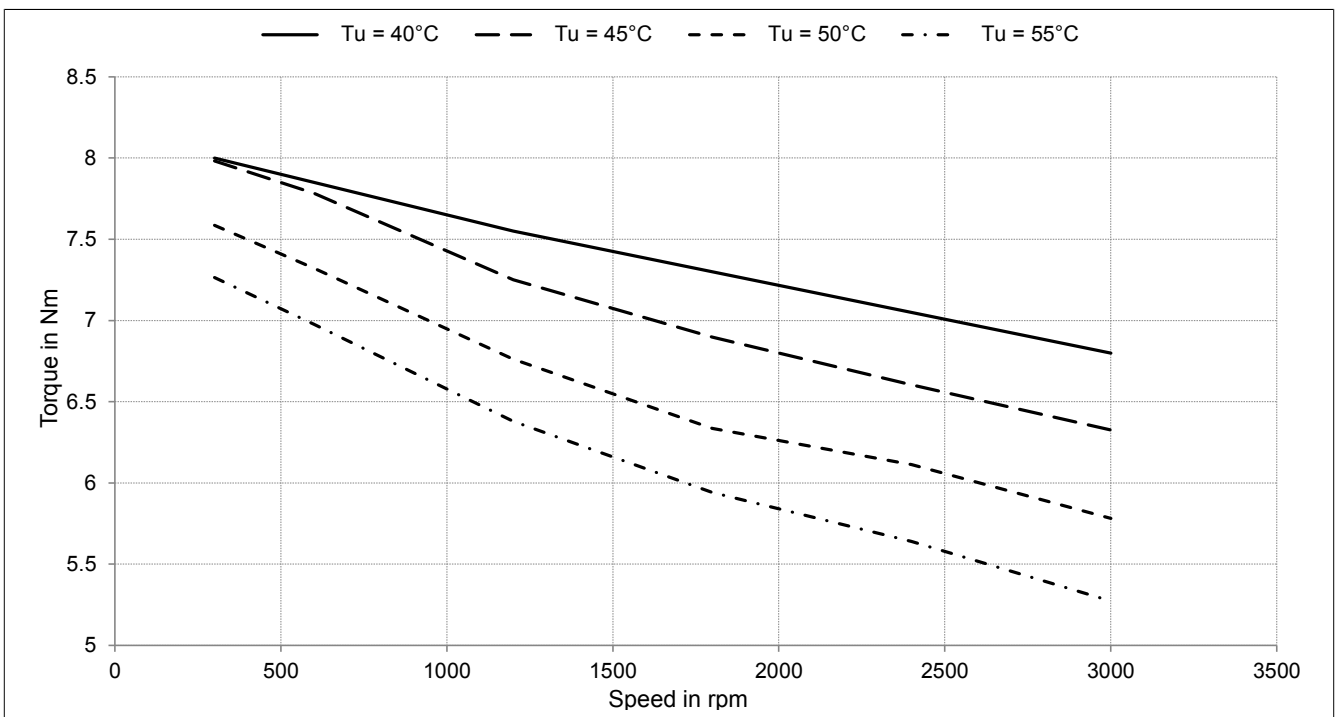

Figure 123: 8DI54e.ffggghi00-1

**8DI54e.ffggghi00-1 with optional fan kit 8ZDFB5000000.000-0**

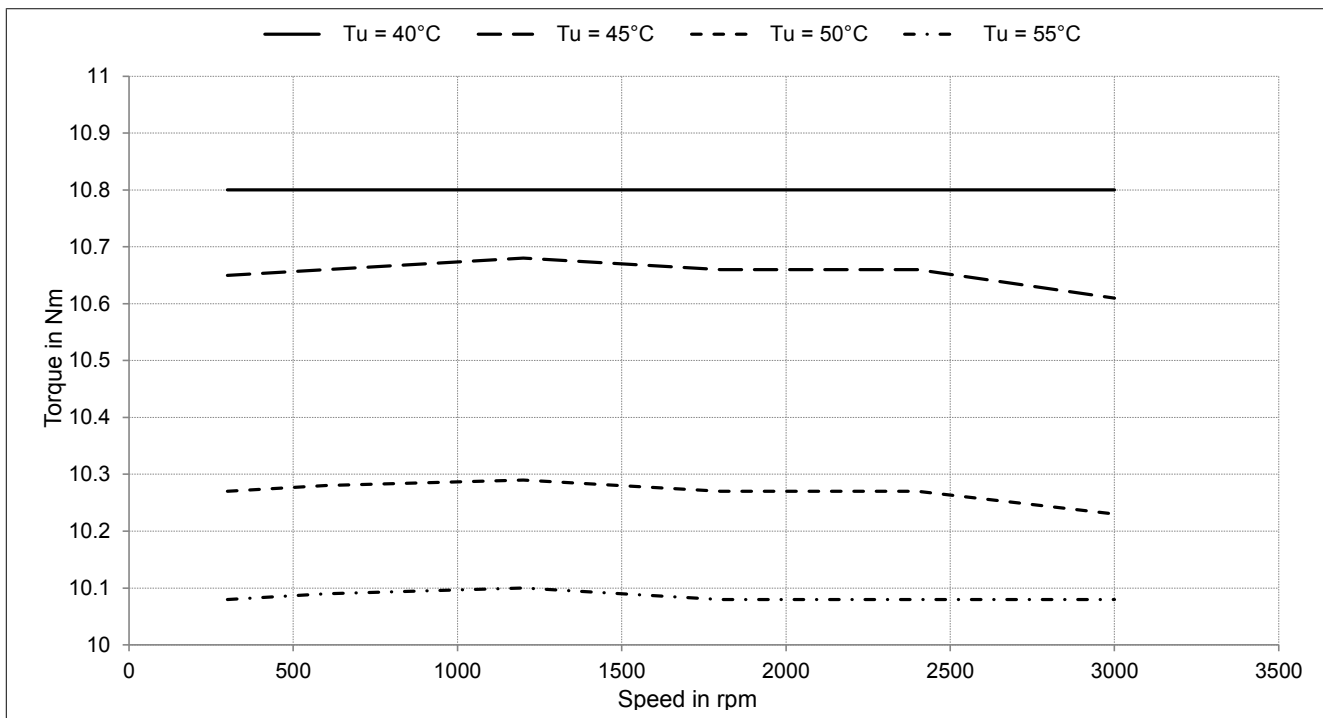

Figure 124: 8DI54e.ffggghi00-1 with optional fan kit 8ZDFB5000000.000-0

**8DI55e.ffggghi00-1**

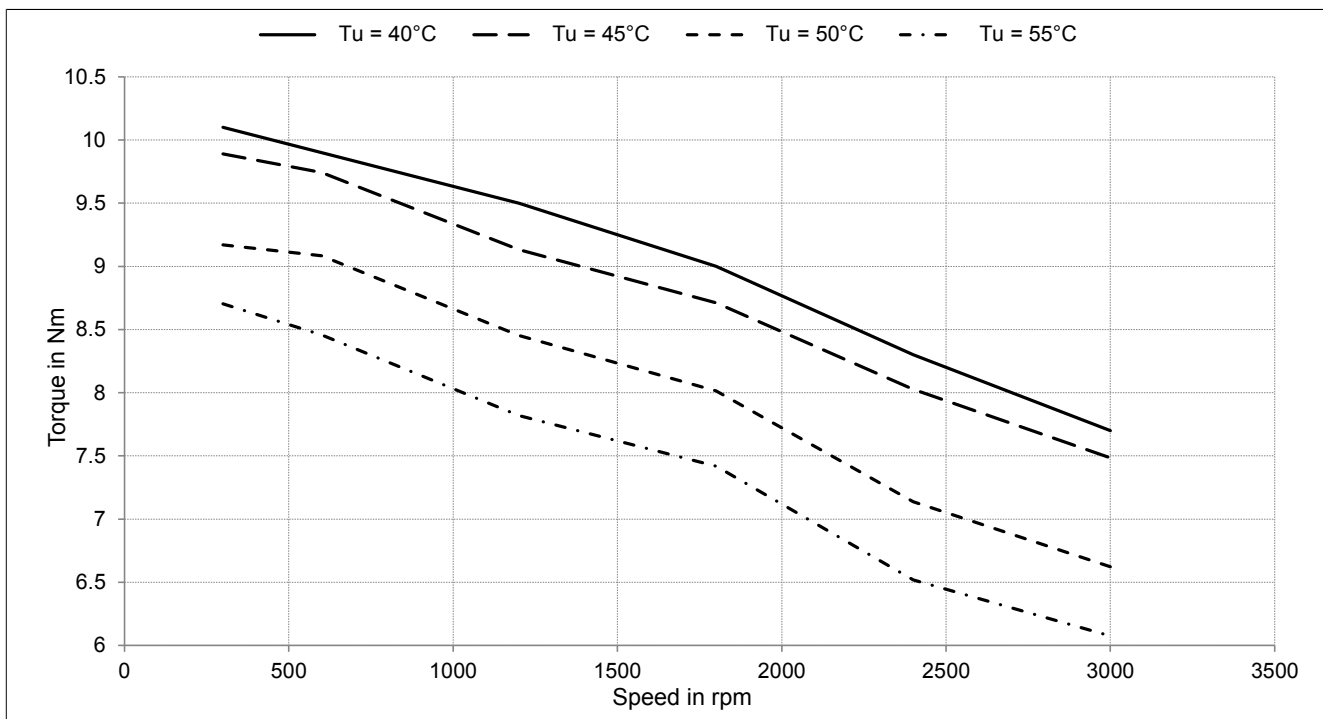

Figure 125: 8DI55e.ffggghi00-1

**8DI55e.ffggghi00-1 with optional fan kit 8ZDFB5000000.000-0**

Figure 126: 8DI55e.ffggghi00-1 with optional fan kit 8ZDFB5000000.000-0

**8DI56e.ffggghi00-1**

Figure 127: 8DI56e.ffggghi00-1

**8DI56e.ffggghi00-1 with optional fan kit 8ZDFB5000000.000-0**

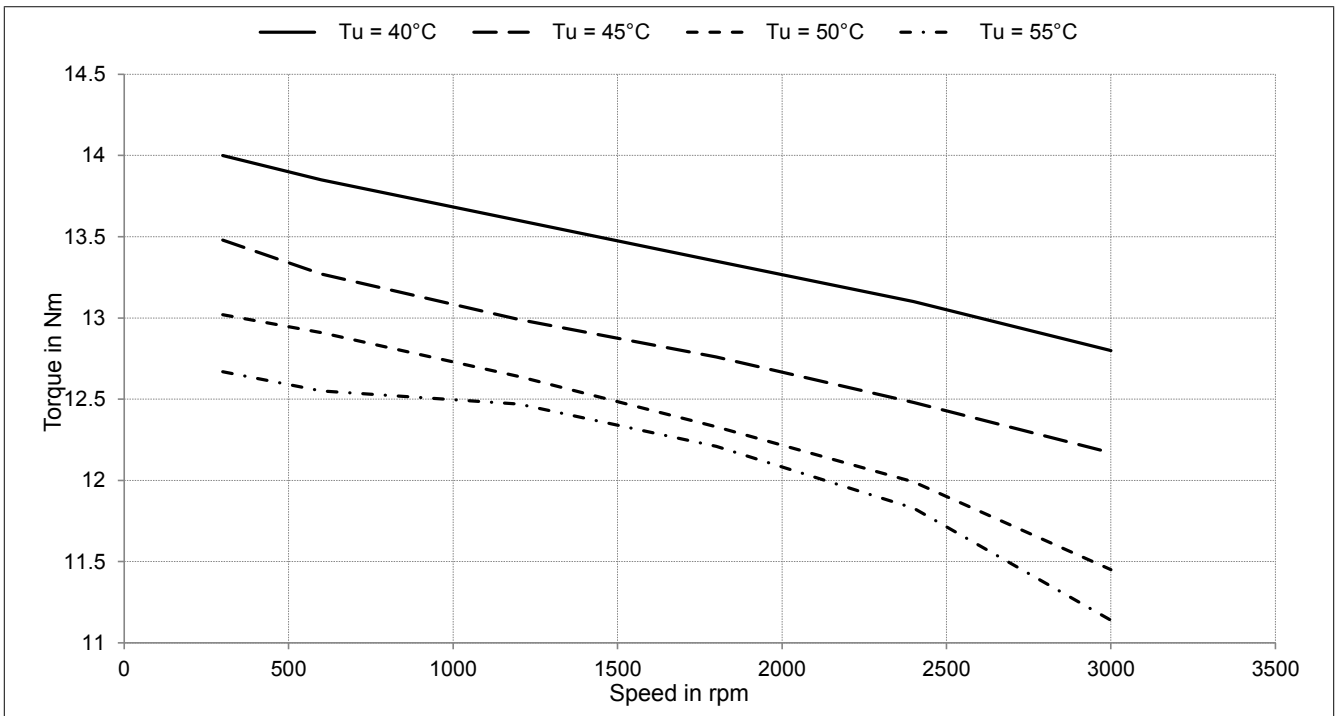

In preparation

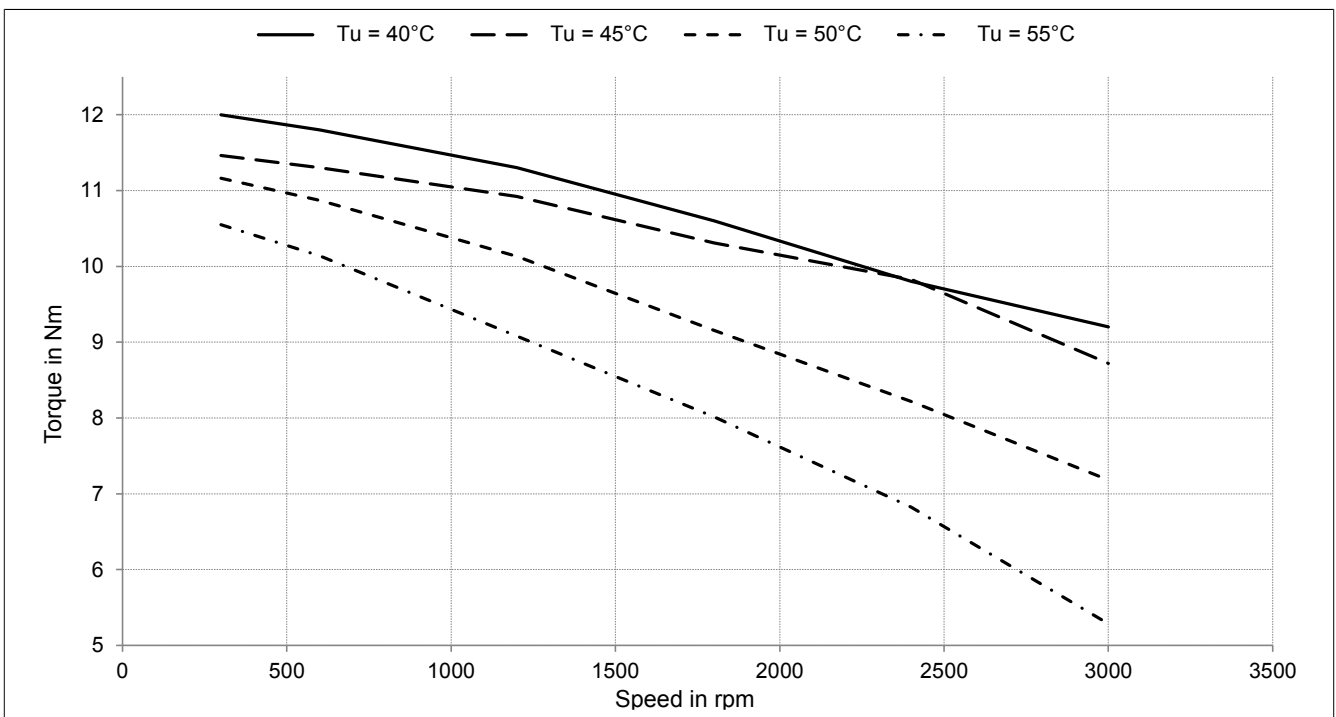
# Appendix B Accessories included in content of delivery

---

## B.1 Decentralized motion control

### B.1.1 8CVE28000HC00.00-1, 8CVIxxxx1HCS0.00-1 and 8DIxxx.xx0xxxx00-1

Figure	Quantity	Name	Model number
	1	Safety notices	MAACPSH-X
	1	Multilingual warning sticker	-

## Appendix C UL Markings

### C.1 ACOPOSremote

- Enclosure Type rating: Type 1
- All field wiring must use 75°C, copper conductors only.
- ACOPOSremote ACOPOSmulti65 inverter modules 8CVI provide motor overload protection at 100% of the FLA Rating.
- Short Circuit Current Rating (SCCR) of combination consisting of rectifier and inverter is specified in the UL Report of the rectifier unit.
- For supply provided by ACOPOSmulti (Vol. 1, Sec. 2) - R/C (JFHR2) fuses 50 201 06.50 or 50 11806.20 (manufactured by Siba) must be installed in common DC bus.
- Integral solid state short circuit protection does not provide branch circuit protection. Branch circuit protection must be provided in accordance with the National Electric Code and any additional local codes.
- For AC mains branch circuit protection of the drive system (combination consisting of rectifier and inverter), use fuses or circuit breaker specified in the UL Report of the rectifier unit.

ACOPOSremote ACOPOSmulti65 inverter modules 8CVI can be used in combination with the following UL approved modules:

- Servo Drive Modules Type ACOPOSmulti, Expansion module – Cat. Nos. 8BVE0500HC00, 8BVE0500HW00
- Open type Servo Drive System, Series ACOPOS P3 - Cat. Nos. 8EI8X8HWD, 8EI8X8HWT, 8EI4X5HWD, 8EI4X5HWT, 8EI2X2HWD, 8EI2X2HWT, 8EI017HWS, 8EI013HWS, 8EI8X8HWS, 8EI4X5HWS, 8EI2X2HWS, 8EI1X6HWS, 8EI8X8MWD, 8EI8X8MWT, 8EI4X5MWD, 8EI4X5MWT, 8EI2X2MWD, 8EI2X2MWT, 8EI8X8MWS, 8EI4X5MWS, 8EI2X2MWS, 8EI1X6MWS, 8EI022HWD, 8EI017HWD, 8EI044HWS, 8EI034HWS, 8EI024HWS

### C.2 ACOPOSmotor

- Enclosure Type rating: Type 1
- All field wiring must use 75°C, copper conductors only.
- Short Circuit Current Rating of combination consisting of rectifier and ACOPOSmotor inverter is specified in the UL Report of the rectifier unit.
- For supply provided by ACOPOSmulti (Vol. 1, Sec. 2) - R/C (JFHR2) fuses 50 201 06.50 or 50 11806.20 (manufactured by Siba) must be installed in common DC bus.
- Integral solid state short circuit protection does not provide branch circuit protection. Branch circuit protection must be provided in accordance with the National Electric Code and any additional local codes.
- For branch circuit protection of the drive system (combination consisting of rectifier and inverter), use fuses or circuit breaker specified in the UL report of the rectifier unit.

ACOPOSmotor modules 8DI can be used in combination with the following UL approved modules:

- Servo Drive Modules Type ACOPOSmulti, Expansion module – Cat. Nos. 8BVE0500HC00, 8BVE0500HW00
- Open type Servo Drive System, Series ACOPOS P3 - Cat. Nos. 8EI8X8HWD, 8EI8X8HWT, 8EI4X5HWD, 8EI4X5HWT, 8EI2X2HWD, 8EI2X2HWT, 8EI017HWS, 8EI013HWS, 8EI8X8HWS, 8EI4X5HWS, 8EI2X2HWS, 8EI1X6HWS, 8EI8X8MWD, 8EI8X8MWT, 8EI4X5MWD, 8EI4X5MWT, 8EI2X2MWD, 8EI2X2MWT, 8EI8X8MWS, 8EI4X5MWS, 8EI2X2MWS, 8EI1X6MWS, 8EI022HWD, 8EI017HWD, 8EI044HWS, 8EI034HWS, 8EI024HWS

### C.3 ACOPOSmotor Compact

- Max. surrounding air temperature is 55°C.
- Only use 8D1CH cables for supplying ACOPOSmotor Compact.

#### CONDITIONS OF ACCEPTABILITY for 8D1

For use only in complete equipment where the acceptability of the combination is determined by UL LLC.

1. These devices shall not to be directly connected to the supply mains of OVC III. Instead they are intended for connection to UL certified dc sources. The power supply shall provide galvanic isolation from mains, its maximum ampacity shall not exceed 60A at 58VDC. The devices shall be protected by supplementary or a branch circuit type dc fuse or circuit breaker with maximum rating not exceeding 35A. This supplementary fuse or circuit breaker are not necessary for 8B0C0320Hx00.B00 or 80PS080X3.
2. Enclosure Type rating 1



Table 1:	8CVI inverter modules - LED status indicators.....	33
Table 2:	POWERLINK - LED status indicators.....	33
Table 3:	RDY, RUN, ERR - LED status indicators.....	33
Table 4:	8CVI045S1HCS0.00-1 - Order data.....	34
Table 5:	8CVI045S1HCS0.00-1 - Technical data.....	35
Table 6:	8CVI045E1HCS0.00-1 - Order data.....	39
Table 7:	8CVI045E1HCS0.00-1 - Technical data.....	40
Table 8:	8CVI045H1HCS0.00-1 - Order data.....	44
Table 9:	8CVI045H1HCS0.00-1 - Technical data.....	45
Table 10:	8CVI088S1HCS0.00-1 - Order data.....	49
Table 11:	8CVI088S1HCS0.00-1 - Technical data.....	50
Table 12:	8CVI088E1HCS0.00-1 - Order data.....	54
Table 13:	8CVI088E1HCS0.00-1 - Technical data.....	55
Table 14:	8CVI088H1HCS0.00-1 - Order data.....	59
Table 15:	8CVI088H1HCS0.00-1 - Technical data.....	60
Table 16:	8CVI155S1HCS0.01-1 - Order data.....	64
Table 17:	8CVI155S1HCS0.01-1 - Technical data.....	65
Table 18:	X4A connector - Pinout.....	69
Table 19:	X11A SinCos connector - Pinout.....	70
Table 20:	EnDat 2.1 connector X11A - Pinout.....	70
Table 21:	HIPERFACE connector X11A - Pinout.....	70
Table 22:	Connector X21x/X22x - Pinout.....	71
Table 23:	X23A, X24A connector - Pinout.....	71
Table 24:	Connector X31x - Pinout.....	71
Table 25:	Ground connection (PE).....	71
Table 26:	8CCM0001.11110-0, 8CCM0002.11110-0, 8CCM0003.11110-0, 8CCM0004.11110-0, 8CCM0005.11110-0 - Order data.....	73
Table 27:	8CCM0001.11110-0, 8CCM0002.11110-0, 8CCM0003.11110-0, 8CCM0004.11110-0, 8CCM0005.11110-0 - Technical data.....	74
Table 28:	Motor cables - Cable construction.....	75
Table 29:	Motor cables - Pinout.....	75
Table 30:	8CCS0001.11110-0, 8CCS0002.11110-0, 8CCS0003.11110-0, 8CCS0004.11110-0, 8CCS0005.11110-0 - Order data.....	76
Table 31:	8CCS0001.11110-0, 8CCS0002.11110-0, 8CCS0003.11110-0, 8CCS0004.11110-0, 8CCS0005.11110-0 - Technical data.....	76
Table 32:	SinCos cables - Cable construction.....	77
Table 33:	SinCos cables - Pinout.....	78
Table 34:	8CCE0001.11210-0, 8CCE0002.11210-0, 8CCE0003.11210-0, 8CCE0004.11210-0, 8CCE0005.11210-0 - Order data.....	79
Table 35:	8CCE0001.11210-0, 8CCE0002.11210-0, 8CCE0003.11210-0, 8CCE0004.11210-0, 8CCE0005.11210-0 - Technical data.....	79
Table 36:	EnDat 2.1 cables - Cable construction.....	80
Table 37:	EnDat 2.1 cables - Pinout.....	81
Table 38:	8CXM000.0000-00, 8CXM000.0002-00, 8CXM000.0005-00, 8CXM000.000A-00 - Order data..	82
Table 39:	8CXM000.0000-00, 8CXM000.0002-00, 8CXM000.0005-00, 8CXM000.000A-00 - Technical data.....	82
Table 40:	8CVE28000HC00.00-1 - Order data.....	84
Table 41:	8CVE28000HC00.00-1 - Technical data.....	84
Table 42:	8CVE remote connection box - LED status indicators.....	88
Table 43:	POWERLINK - LED status indicators.....	88
Table 44:	Connector X1 - Pinout.....	90
Table 45:	Connector X2 - Pinout.....	91
Table 46:	Connector X4 - Pinout.....	91
Table 47:	Connector X4 - Pinout.....	91
Table 48:	Connector X21x/X22x - Pinout.....	91
Table 49:	Connector X31x - Pinout.....	91
Table 50:	Ground connection (PE).....	92
Table 51:	8CXC001.0000-00 - Order data.....	96

Table 52:	8CXC001.0000-00 - Technical data.....	96
Table 53:	8CXM001.0000-00, 8CXM001.0002-00, 8CXM001.0005-00, 8CXM001.000A-00 - Order data..	96
Table 54:	8CXM001.0000-00, 8CXM001.0002-00, 8CXM001.0005-00, 8CXM001.000A-00 - Technical data.....	96
Table 55:	8CXS001.0000-00, 8CXS001.0002-00, 8CXS001.0005-00, 8CXS001.000A-00 - Order data....	97
Table 56:	8CXS001.0000-00, 8CXS001.0002-00, 8CXS001.0005-00, 8CXS001.000A-00 - Order data....	97
Table 57:	8CXS001.0000-00, 8CXS001.0002-00, 8CXS001.0005-00, 8CXS001.000A-00 - Technical data	97
Table 58:	8CXS000.0000-00 - Order data.....	97
Table 59:	8CXS000.0000-00 - Technical data.....	98
Table 60:	8CXS002.0000-00, 8CXS002.0002-00, 8CXS002.0005-00, 8CXS002.000A-00 - Order data....	98
Table 61:	8CXS002.0000-00, 8CXS002.0002-00, 8CXS002.0005-00, 8CXS002.000A-00 - Technical data	98
Table 62:	ACOPOSmotor SafeMOTION: Safety functions and associated safety levels.....	100
Table 63:	Technical data for the holding brake per ACOPOSmotor module.....	102
Table 64:	POWERLINK - LED status indicators.....	105
Table 65:	RDY/ERR - LED status indicators.....	105
Table 66:	Status changes when starting up the operating system loader.....	106
Table 67:	8BVI SafeMOTION inverter modules (1-axis modules) - LED status indicators.....	106
Table 68:	RDY/ERR - LED status indicators.....	107
Table 69:	POWERLINK - LED status indicators.....	107
Table 70:	SafeMOTION module - LED status indicators.....	107
Table 71:	Status changes when starting up the operating system loader.....	108
Table 72:	8DIcde.ffggg7i00-1 - Order data.....	109
Table 73:	8DIcde.ffggg0i00-1 - Order data.....	110
Table 74:	Technical data.....	111
Table 75:	8DIcde.ffggg7i00-1, 8DIcde.ffggg0i00-1 - Technical data.....	112
Table 76:	8DI33x.ff045hi00-1, 8DI34x.ff045hi00-1 - Technical data.....	114
Table 77:	8DI330.ff045hi00-1, 8DI340.ff045hi00-1 - Technical data.....	114
Table 78:	8DI44x.ff022hi00-1, 8DI45x.ff022hi00-1, 8DI46x.ff022hi00-1 - Technical data.....	118
Table 79:	8DI440.ff022hi00-1, 8DI450.ff022hi00-1, 8DI460.ff022hi00-1 - Technical data.....	118
Table 80:	8DI54x.ff022hi00-1, 8DI55x.ff022hi00-1, 8DI56x.ff022hi00-1 - Technical data.....	123
Table 81:	8DI540.ff022hi00-1, 8DI550.ff022hi00-1, 8DI560.ff022hi00-1 - Technical data.....	123
Table 82:	Type of construction and mounting arrangement per EN 60034-7 (IM code).....	136
Table 83:	Pinout overview.....	137
Table 84:	Connector X21 - Pinout.....	138
Table 85:	Connector X23A - Pinout.....	138
Table 86:	Connector X31 - Pinout.....	139
Table 87:	Ground connection (PE).....	139
Table 88:	POWERLINK node number setting.....	139
Table 89:	POWERLINK - LED status indicators.....	150
Table 90:	RDY/ERR - LED status indicators.....	150
Table 91:	Status changes when starting up the operating system loader.....	151
Table 92:	8D1bcd.efghijkhh-1 - Order data.....	152
Table 93:	Technical data.....	153
Table 94:	8D1bcd.efghijkhh-1 - Technical data.....	154
Table 95:	8D1A22.elg000000-1, 8D1A23.eDg000000-1, 8D1A23.eHg000000-1 - Technical data.....	157
Table 96:	8D1B22.elgBDDk00-1, 8D1B22.elgBDFk00-1, 8D1B22.elgBDHk00-1, 8D1B22.elgBDJk00-1, 8D1B22.elgBDLk00-1 - Technical data.....	161
Table 97:	8D1B22.elgBDMk00-1, 8D1B22.elgBDNk00-1, 8D1B22.elgBDQk00-1, 8D1B22.elgBDTk00-1, 8D1B22.elgBDWk00-1 - Technical data.....	162
Table 98:	8D1B22.elgCFDk00-1, 8D1B22.elgCFFk00-1, 8D1B22.elgCFHk00-1, 8D1B22.elgCFJk00-1, 8D1B22.elgCFLk00-1 - Technical data.....	163
Table 99:	8D1B22.elgCFMk00-1, 8D1B22.elgCFNk00-1, 8D1B22.elgCFQk00-1, 8D1B22.elgCFTk00-1, 8D1B22.elgCFWk00-1 - Technical data.....	164
Table 100:	8D1B22.elgDGDk00-1, 8D1B22.elgDGFk00-1, 8D1B22.elgDGHk00-1, 8D1B22.elgDGJk00-1, 8D1B22.elgDGLk00-1 - Technical data.....	165
Table 101:	8D1B22.elgDGMk00-1, 8D1B22.elgDGNk00-1, 8D1B22.elgDGQk00-1, 8D1B22.elgDGTk00-1, 8D1B22.elgDGWk00-1 - Technical data.....	166

Table 102:	8D1B22.elgEDDk00-1, 8D1B22.elgEDFk00-1, 8D1B22.elgEDHk00-1, 8D1B22.elgEDJk00-1, 8D1B22.elgEDLk00-1 - Technical data.....	167
Table 103:	8D1B22.elgEDMk00-1, 8D1B22.elgEDNk00-1, 8D1B22.elgEDQk00-1, 8D1B22.elgEDTk00-1, 8D1B22.elgEDWk00-1 - Technical data.....	168
Table 104:	8D1B22.elgHEDk00-1, 8D1B22.elgHEFk00-1, 8D1B22.elgHEHk00-1, 8D1B22.elgHEJk00-1, 8D1B22.elgHELk00-1 - Technical data.....	169
Table 105:	8D1B22.elgHEMk00-1, 8D1B22.elgHENk00-1, 8D1B22.elgHEQk00-1, 8D1B22.elgHETk00-1, 8D1B22.elgHEWk00-1 - Technical data.....	170
Table 106:	8D1B23.eDgBDDk00-1, 8D1B23.eDgBDFk00-1, 8D1B23.eDgBDHk00-1, 8D1B23.eDgBDJk00-1, 8D1B23.eDgBDLk00-1 - Technical data.....	171
Table 107:	8D1B23.eDgBDMk00-1, 8D1B23.eDgBDNk00-1, 8D1B23.eDgBDQk00-1, 8D1B23.eDgBDTk00-1, 8D1B23.eDgBDWk00-1 - Technical data.....	172
Table 108:	8D1B23.eDgCFDk00-1, 8D1B23.eDgCFFk00-1, 8D1B23.eDgCFHk00-1, 8D1B23.eDgCFJk00-1, 8D1B23.eDgCFLk00-1 - Technical data.....	173
Table 109:	8D1B23.eDgCFMk00-1, 8D1B23.eDgCFNk00-1, 8D1B23.eDgCFQk00-1, 8D1B23.eDgCFTk00-1, 8D1B23.eDgCFWk00-1 - Technical data.....	174
Table 110:	8D1B23.eDgDGDk00-1, 8D1B23.eDgDGFk00-1, 8D1B23.eDgDGHk00-1, 8D1B23.eDgDGJk00-1, 8D1B23.eDgDGLk00-1 - Technical data.....	175
Table 111:	8D1B23.eDgDGMk00-1, 8D1B23.eDgDGNk00-1, 8D1B23.eDgDGQk00-1, 8D1B23.eDgDGTk00-1, 8D1B23.eDgDGWk00-1 - Technical data.....	176
Table 112:	8D1B23.eDgEDDk00-1, 8D1B23.eDgEDFk00-1, 8D1B23.eDgEDHk00-1, 8D1B23.eDgEDJk00-1, 8D1B23.eDgEDLk00-1 - Technical data.....	177
Table 113:	8D1B23.eDgEDMk00-1, 8D1B23.eDgEDNk00-1, 8D1B23.eDgEDQk00-1, 8D1B23.eDgEDTk00-1, 8D1B23.eDgEDWk00-1 - Technical data.....	178
Table 114:	8D1B23.eDgHEDk00-1, 8D1B23.eDgHEFk00-1, 8D1B23.eDgHEHk00-1, 8D1B23.eDgHEJk00-1, 8D1B23.eDgHELk00-1 - Technical data.....	179
Table 115:	8D1B23.eDgHEMk00-1, 8D1B23.eDgHENk00-1, 8D1B23.eDgHEQk00-1, 8D1B23.eDgHETk00-1, 8D1B23.eDgHEWk00-1 - Technical data.....	180
Table 116:	8D1B23.eHgBDDk00-1, 8D1B23.eHgBDFk00-1, 8D1B23.eHgBDHk00-1, 8D1B23.eHgBDJk00-1, 8D1B23.eHgBDLk00-1 - Technical data.....	181
Table 117:	8D1B23.eHgBDMk00-1, 8D1B23.eHgBDNk00-1, 8D1B23.eHgBDQk00-1, 8D1B23.eHgBDTk00-1, 8D1B23.eHgBDWk00-1 - Technical data.....	182
Table 118:	8D1B23.eHgCFDk00-1, 8D1B23.eHgCFFk00-1, 8D1B23.eHgCFHk00-1, 8D1B23.eHgCFJk00-1, 8D1B23.eHgCFLk00-1 - Technical data.....	183
Table 119:	8D1B23.eHgCFMk00-1, 8D1B23.eHgCFNk00-1, 8D1B23.eHgCFQk00-1, 8D1B23.eHgCFTk00-1, 8D1B23.eHgCFWk00-1 - Technical data.....	184
Table 120:	8D1B23.eHgDGDk00-1, 8D1B23.eHgDGFk00-1, 8D1B23.eHgDGHk00-1, 8D1B23.eHgDGJk00-1, 8D1B23.eHgDGLk00-1 - Technical data.....	185
Table 121:	8D1B23.eHgDGMk00-1, 8D1B23.eHgDGNk00-1, 8D1B23.eHgDGQk00-1, 8D1B23.eHgDGTk00-1, 8D1B23.eHgDGWk00-1 - Technical data.....	186
Table 122:	8D1B23.eHgEDDk00-1, 8D1B23.eHgEDFk00-1, 8D1B23.eHgEDHk00-1, 8D1B23.eHgEDJk00-1, 8D1B23.eHgEDLk00-1 - Technical data.....	187
Table 123:	8D1B23.eHgEDMk00-1, 8D1B23.eHgEDNk00-1, 8D1B23.eHgEDQk00-1, 8D1B23.eHgEDTk00-1, 8D1B23.eHgEDWk00-1 - Technical data.....	188
Table 124:	8D1B23.eHgHEDk00-1, 8D1B23.eHgHEFk00-1, 8D1B23.eHgHEHk00-1, 8D1B23.eHgHEJk00-1, 8D1B23.eHgHELk00-1 - Technical data.....	189
Table 125:	8D1B23.eHgHEMk00-1, 8D1B23.eHgHENk00-1, 8D1B23.eHgHEQk00-1, 8D1B23.eHgHETk00-1, 8D1B23.eHgHEWk00-1 - Technical data.....	190
Table 126:	8D1C22, 8D1C23, 8D1C23 - Technical data.....	191
Table 127:	8GP40-060hh003klmm, 8GP40-060hh004klmm, 8GP40-060hh007klmm, 8GP40-060hh009klmm, 8GP40-060hh012klmm, 8GP40-060hh016klmm - Technical data.....	193
Table 128:	8GP40-080hh003klmm, 8GP40-080hh004klmm, 8GP40-080hh005klmm, 8GP40-080hh007klmm, 8GP40-080hh008klmm, 8GP40-080hh010klmm - Technical data.....	194
Table 129:	8GP40-080hh009klmm, 8GP40-080hh012klmm, 8GP40-080hh015klmm, 8GP40-080hh016klmm, 8GP40-080hh020klmm, 8GP40-080hh025klmm - Technical data.....	195
Table 130:	8GP40-080hh032klmm, 8GP40-080hh040klmm, 8GP40-080hh064klmm, 8GP40-080hh100klmm, 8GP40-080hh060klmm, 8GP40-080hh080klmm - Technical data.....	196
Table 131:	8GP45-067hh003klmm, 8GP45-067hh004klmm, 8GP45-067hh007klmm, 8GP45-067hh009klmm, 8GP45-067hh012klmm, 8GP45-067hh016klmm - Technical data.....	197

Table 132:	8GP45-089hh003klmm, 8GP45-089hh004klmm, 8GP45-089hh005klmm, 8GP45-089h- h007klmm, 8GP45-089hh008klmm, 8GP45-089hh010klmm - Technical data.....	198
Table 133:	8GP45-089hh009klmm, 8GP45-089hh012klmm, 8GP45-089hh015klmm, 8GP45-089h- h016klmm, 8GP45-089hh020klmm, 8GP45-089hh025klmm - Technical data.....	199
Table 134:	8GP45-089hh032klmm, 8GP45-089hh040klmm, 8GP45-089hh060klmm, 8GP45-089h- h064klmm, 8GP45-089hh080klmm, 8GP45-089hh100klmm - Technical data.....	200
Table 135:	8GP50-070hh003klmm, 8GP50-070hh004klmm, 8GP50-070hh007klmm, 8GP50-070h- h009klmm, 8GP50-070hh012klmm, 8GP50-070hh016klmm - Technical data.....	201
Table 136:	8GP50-090hh003klmm, 8GP50-090hh004klmm, 8GP50-090hh005klmm, 8GP50-090h- h007klmm, 8GP50-090hh008klmm, 8GP50-090hh010klmm - Technical data.....	202
Table 137:	8GP50-090hh009klmm, 8GP50-090hh012klmm, 8GP50-090hh015klmm, 8GP50-090h- h016klmm, 8GP50-090hh020klmm, 8GP50-090hh025klmm - Technical data.....	203
Table 138:	8GP50-090hh032klmm, 8GP50-090hh040klmm, 8GP50-090hh064klmm, 8GP50-090hh100klmm - Technical data.....	204
Table 139:	8GP55-060hh003klmm, 8GP55-060hh004klmm, 8GP55-060hh007klmm, 8GP55-060h- h009klmm, 8GP55-060hh012klmm, 8GP55-060hh016klmm - Technical data.....	205
Table 140:	8GP55-080hh003klmm, 8GP55-080hh004klmm, 8GP55-080hh005klmm, 8GP55-080h- h007klmm, 8GP55-080hh008klmm, 8GP55-080hh010klmm - Technical data.....	206
Table 141:	8GP55-080hh009klmm, 8GP55-080hh012klmm, 8GP55-080hh015klmm, 8GP55-080h- h016klmm, 8GP55-080hh020klmm, 8GP55-080hh025klmm - Technical data.....	207
Table 142:	8GP55-080hh032klmm, 8GP55-080hh040klmm, 8GP55-080hh064klmm, 8GP55-080hh100klmm - Technical data.....	208
Table 143:	8GP60-070hh003klmm, 8GP60-070hh004klmm, 8GP60-070hh005klmm, 8GP60-070h- h007klmm, 8GP60-070hh008klmm, 8GP60-070hh010klmm - Technical data.....	209
Table 144:	8GP60-070hh012klmm, 8GP60-070hh015klmm, 8GP60-070hh016klmm, 8GP60-070h- h020klmm, 8GP60-070hh025klmm, 8GP60-070hh032klmm - Technical data.....	210
Table 145:	8GP60-070hh040klmm, 8GP60-070hh064klmm, 8GP60-070hh100klmm - Technical data.....	211
Table 146:	8GP70-070hh003klmm, 8GP70-070hh004klmm, 8GP70-070hh005klmm, 8GP70-070h- h007klmm, 8GP70-070hh010klmm, 8GP70-070hh012klmm - Technical data.....	212
Table 147:	8GP70-070hh015klmm, 8GP70-070hh016klmm, 8GP70-070hh020klmm, 8GP70-070h- h025klmm, 8GP70-070hh035klmm, 8GP70-070hh040klmm - Technical data.....	213
Table 148:	8GP70-070hh050klmm, 8GP70-070hh070klmm, 8GP70-070hh100klmm - Technical data.....	214
Table 149:	8GF40-064hh003klmm, 8GF40-064hh004klmm, 8GF40-064hh007klmm, 8GF40-064hh009klmm, 8GF40-064hh012klmm, 8GF40-064hh016klmm - Technical data.....	215
Table 150:	8GF60-064hh004klmm, 8GF60-064hh005klmm, 8GF60-064hh007klmm, 8GF60-064hh008klmm, 8GF60-064hh010klmm, 8GF60-064hh016klmm - Technical data.....	216
Table 151:	8GF60-064hh020klmm, 8GF60-064hh025klmm, 8GF60-064hh032klmm, 8GF60-064hh040klmm, 8GF60-064hh050klmm, 8GF60-064hh064klmm - Technical data.....	217
Table 152:	8GF60-064hh100klmm - Technical data.....	218
Table 153:	8GF70-064hh004klmm, 8GF70-064hh005klmm, 8GF70-064hh007klmm, 8GF70-064hh010klmm, 8GF70-064hh016klmm, 8GF70-064hh020klmm - Technical data.....	219
Table 154:	8GF70-064hh025klmm, 8GF70-064hh035klmm, 8GF70-064hh040klmm, 8GF70-064hh050klmm, 8GF70-064hh070klmm, 8GF70-064hh100klmm - Technical data.....	220
Table 155:	8GA40-060hh003klmm, 8GA40-060hh004klmm, 8GA40-060hh005klmm, 8GA40-060h- h007klmm, 8GA40-060hh008klmm, 8GA40-060hh009klmm - Technical data.....	221
Table 156:	8GA40-060hh010klmm, 8GA40-060hh012klmm, 8GA40-060hh015klmm, 8GA40-060h- h016klmm, 8GA40-060hh020klmm, 8GA40-060hh025klmm - Technical data.....	222
Table 157:	8GA40-060hh032klmm, 8GA40-060hh040klmm, 8GA40-060hh060klmm, 8GA40-060h- h064klmm, 8GA40-060hh080klmm, 8GA40-060hh100klmm - Technical data.....	223
Table 158:	8GA40-080hh003klmm, 8GA40-080hh004klmm, 8GA40-080hh005klmm, 8GA40-080h- h007klmm, 8GA40-080hh008klmm, 8GA40-080hh009klmm - Technical data.....	224
Table 159:	8GA40-080hh010klmm, 8GA40-080hh012klmm, 8GA40-080hh015klmm, 8GA40-080h- h016klmm, 8GA40-080hh020klmm, 8GA40-080hh025klmm - Technical data.....	225
Table 160:	8GA40-080hh032klmm, 8GA40-080hh040klmm, 8GA40-080hh064klmm, 8GA40-080h- h060klmm, 8GA40-080hh080klmm, 8GA40-080hh100klmm - Technical data.....	226
Table 161:	8GA45-067hh003klmm, 8GA45-067hh004klmm, 8GA45-067hh005klmm, 8GA45-067h- h007klmm, 8GA45-067hh008klmm, 8GA45-067hh009klmm - Technical data.....	227
Table 162:	8GA45-067hh010klmm, 8GA45-067hh012klmm, 8GA45-067hh015klmm, 8GA45-067h- h016klmm, 8GA45-067hh020klmm, 8GA45-067hh025klmm - Technical data.....	228

Table 163:	8GA45-067hh032klmm, 8GA45-067hh040klmm, 8GA45-067hh060klmm, 8GA45-067h- h064klmm, 8GA45-067hh080klmm, 8GA45-067hh100klmm - Technical data.....	229
Table 164:	8GA45-089hh003klmm, 8GA45-089hh004klmm, 8GA45-089hh005klmm, 8GA45-089h- h007klmm, 8GA45-089hh008klmm, 8GA45-089hh009klmm - Technical data.....	230
Table 165:	8GA45-089hh010klmm, 8GA45-089hh012klmm, 8GA45-089hh015klmm, 8GA45-089h- h016klmm, 8GA45-089hh020klmm, 8GA45-089hh025klmm - Technical data.....	231
Table 166:	8GA45-089hh032klmm, 8GA45-089hh040klmm, 8GA45-089hh060klmm, 8GA45-089h- h064klmm, 8GA45-089hh080klmm, 8GA45-089hh100klmm - Technical data.....	232
Table 167:	8GA50-070hh003klmm, 8GA50-070hh004klmm, 8GA50-070hh005klmm, 8GA50-070h- h007klmm, 8GA50-070hh008klmm, 8GA50-070hh009klmm - Technical data.....	233
Table 168:	8GA50-070hh010klmm, 8GA50-070hh012klmm, 8GA50-070hh015klmm, 8GA50-070h- h016klmm, 8GA50-070hh020klmm, 8GA50-070hh025klmm - Technical data.....	234
Table 169:	8GA50-070hh032klmm, 8GA50-070hh040klmm, 8GA50-070hh064klmm, 8GA50-070hh100klmm - Technical data.....	235
Table 170:	8GA50-090hh003klmm, 8GA50-090hh004klmm, 8GA50-090hh005klmm, 8GA50-090h- h007klmm, 8GA50-090hh008klmm, 8GA50-090hh009klmm - Technical data.....	236
Table 171:	8GA50-090hh010klmm, 8GA50-090hh012klmm, 8GA50-090hh015klmm, 8GA50-090h- h016klmm, 8GA50-090hh020klmm, 8GA50-090hh025klmm - Technical data.....	237
Table 172:	8GA50-090hh032klmm, 8GA50-090hh040klmm, 8GA50-090hh064klmm, 8GA50-090hh100klmm - Technical data.....	238
Table 173:	8GA55-064hh003klmm, 8GA55-064hh004klmm, 8GA55-064hh005klmm, 8GA55-064h- h007klmm, 8GA55-064hh008klmm, 8GA55-064hh009klmm - Technical data.....	239
Table 174:	8GA55-064hh010klmm, 8GA55-064hh012klmm, 8GA55-064hh015klmm, 8GA55-064h- h016klmm, 8GA55-064hh020klmm, 8GA55-064hh025klmm - Technical data.....	240
Table 175:	8GA55-064hh032klmm, 8GA55-064hh040klmm, 8GA55-064hh064klmm, 8GA55-064hh100klmm - Technical data.....	241
Table 176:	8GA60-070hh004klmm, 8GA60-070hh005klmm, 8GA60-070hh008klmm, 8GA60-070h- h010klmm, 8GA60-070hh016klmm, 8GA60-070hh020klmm - Technical data.....	242
Table 177:	8GA60-070hh025klmm, 8GA60-070hh032klmm, 8GA60-070hh040klmm, 8GA60-070h- h050klmm, 8GA60-070hh064klmm, 8GA60-070hh100klmm - Technical data.....	243
Table 178:	X23A, X24A connector - Pinout.....	252
Table 179:	POWERLINK node number setting.....	252
Table 180:	Selecting the cross section of the protective ground conductor.....	254
Table 181:	Maximum current load for specially insulated three-phase cables .....	255
Table 182:	Maximum current load for PVC-insulated three-phase cables .....	256
Table 183:	Selecting the cross section of the protective ground conductor.....	268
Table 184:	Selecting the cross section of the protective ground conductor.....	273
Table 185:	Safety classifications, criteria and characteristics for safe pulse disabling.....	309
Table 186:	Overview of safety functions according to standards.....	309
Table 187:	List of possible errors.....	313
Table 188:	Safety classifications, criteria and characteristic values for safety function STO.....	335
Table 189:	Overview of safety functions according to standards.....	335
Table 190:	List of possible fault events.....	341
Table 191:	8CCH0005.11120-1, 8CCH0007.11120-1, 8CCH0010.11120-1, 8CCH0015.11120-1, 8CCH0020.11120-1, 8CCH0025.11120-1 - Order data.....	357
Table 192:	8CCH0005.11120-1, 8CCH0007.11120-1, 8CCH0010.11120-1, 8CCH0015.11120-1, 8CCH0020.11120-1, 8CCH0025.11120-1 - Technical data.....	357
Table 193:	One-sided hybrid cable - Cable construction.....	360
Table 194:	Custom cable length.....	360
Table 195:	RJ45 connector - Pinout.....	360
Table 196:	8CCH0005.11110-1, 8CCH0007.11110-1, 8CCH0010.11110-1, 8CCH0015.11110-1, 8CCH0020.11110-1 - Order data.....	362
Table 197:	8CCH0005.11110-1, 8CCH0007.11110-1, 8CCH0010.11110-1, 8CCH0015.11110-1, 8CCH0020.11110-1 - Technical data.....	362
Table 198:	Hybrid cables - Cable construction.....	363
Table 199:	8CCH0001.11130-1, 8CCH0002.11130-1, 8CCH0003.11130-1, 8CCH0004.11130-1, 8CCH0005.11130-1 - Order data.....	364
Table 200:	8CCH0001.11130-1, 8CCH0002.11130-1, 8CCH0003.11130-1, 8CCH0004.11130-1, 8CCH0005.11130-1 - Technical data.....	365

Table 201:	Hybrid cables - Cable construction.....	366
Table 202:	8CCH0001.11230-1, 8CCH0002.11230-1, 8CCH0003.11230-1, 8CCH0004.11230-1, 8CCH0005.11230-1 - Order data.....	367
Table 203:	8CCH0001.11230-1, 8CCH0002.11230-1, 8CCH0003.11230-1, 8CCH0004.11230-1, 8CCH0005.11230-1 - Technical data.....	368
Table 204:	Hybrid cables - Cable construction.....	369
Table 205:	8CCH0005.11220-1, 8CCH0007.11220-1, 8CCH0010.11220-1, 8CCH0015.11220-1, 8CCH0020.11220-1 - Order data.....	370
Table 206:	8CCH0005.11220-1, 8CCH0007.11220-1, 8CCH0010.11220-1, 8CCH0015.11220-1, 8CCH0020.11220-1 - Technical data.....	371
Table 207:	One-sided hybrid cable 8CCHxxxx.11220-1 - Cable construction.....	372
Table 208:	8ZDFB4000000.000-0 - Order data.....	374
Table 209:	8ZDFB4000000.000-0 - Technical data.....	374
Table 210:	8ZDFB5000000.000-0 - Order data.....	375
Table 211:	8ZDFB5000000.000-0 - Technical data.....	375
Table 212:	8CXC000.0000-00 - Order data.....	377
Table 213:	8CXC000.0000-00 - Technical data.....	377
Table 214:	X67AC0M08 - Order data.....	378
Table 215:	X67AC0M08 - Technical data.....	378
Table 216:	X67AC0M12 - Order data.....	378
Table 217:	X67AC0M12 - Technical data.....	378
Table 218:	8D1CH0003.11120-0, 8D1CH0005.11120-0, 8D1CH0010.11120-0, 8D1CH0015.11120-0 - Order data.....	379
Table 219:	8D1CH0003.11120-0, 8D1CH0005.11120-0, 8D1CH0010.11120-0, 8D1CH0015.11120-0 - Technical data.....	379
Table 220:	8D1CH00X5.11110-0, 8D1CH0001.11110-0, 8D1CH0002.11110-0, 8D1CH0003.11110-0, 8D1CH0005.11110-0, 8D1CH0010.11110-0, 8D1CH0015.11110-0 - Order data.....	381
Table 221:	8D1CH00X5.11110-0, 8D1CH0001.11110-0, 8D1CH0002.11110-0, 8D1CH0003.11110-0, 8D1CH0005.11110-0, 8D1CH0010.11110-0, 8D1CH0015.11110-0 - Technical data.....	381
Table 222:	X67CA0Dxx - Technical data.....	384
Table 223:	Overview of stop function categories.....	395
Table 224:	Overview of performance levels (PL).....	395



8CCE0001.11210-0.....	79
8CCE0002.11210-0.....	79
8CCE0003.11210-0.....	79
8CCE0004.11210-0.....	79
8CCE0005.11210-0.....	79
8CCH0001.11130-1.....	364
8CCH0001.11230-1.....	367
8CCH0002.11130-1.....	364
8CCH0002.11230-1.....	367
8CCH0003.11130-1.....	364
8CCH0003.11230-1.....	367
8CCH0004.11130-1.....	364
8CCH0004.11230-1.....	367
8CCH0005.11110-1.....	362
8CCH0005.11120-1.....	357
8CCH0005.11130-1.....	364
8CCH0005.11220-1.....	370
8CCH0005.11230-1.....	367
8CCH0007.11110-1.....	362
8CCH0007.11120-1.....	357
8CCH0007.11220-1.....	370
8CCH0010.11110-1.....	362
8CCH0010.11120-1.....	357
8CCH0010.11220-1.....	370
8CCH0015.11110-1.....	362
8CCH0015.11120-1.....	357
8CCH0015.11220-1.....	370
8CCH0020.11110-1.....	362
8CCH0020.11120-1.....	357
8CCH0020.11220-1.....	370
8CCH0025.11120-1.....	357
8CCM0001.11110-0.....	73
8CCM0002.11110-0.....	73
8CCM0003.11110-0.....	73
8CCM0004.11110-0.....	73
8CCM0005.11110-0.....	73
8CCS0001.11110-0.....	76
8CCS0002.11110-0.....	76
8CCS0003.11110-0.....	76
8CCS0004.11110-0.....	76
8CCS0005.11110-0.....	76
8CVE28000HC00.00-1.....	84
8CVI045E1HCS0.00-1.....	39
8CVI045H1HCS0.00-1.....	44
8CVI045S1HCS0.00-1.....	34
8CVI088E1HCS0.00-1.....	54
8CVI088H1HCS0.00-1.....	59
8CVI088S1HCS0.00-1.....	49
8CVI155S1HCS0.01-1.....	64
8CXC000.0000-00.....	377
8CXC001.0000-00.....	96
8CXM000.0000-00.....	82
8CXM000.0002-00.....	82
8CXM000.0005-00.....	82
8CXM000.000A-00.....	82
8CXM001.0000-00.....	96
8CXM001.0002-00.....	96
8CXM001.0005-00.....	96
8CXM001.000A-00.....	96
8CXS000.0000-00.....	97
8CXS001.0000-00.....	97
8CXS001.0002-00.....	97

8CXS001.0005-00.....	97
8CXS001.000A-00.....	97
8CXS002.0000-00.....	98
8CXS002.0002-00.....	98
8CXS002.0005-00.....	98
8CXS002.000A-00.....	98
8D1CH0001.11110-0.....	381
8D1CH0002.11110-0.....	381
8D1CH0003.11110-0.....	381
8D1CH0003.11120-0.....	379
8D1CH0005.11110-0.....	381
8D1CH0005.11120-0.....	379
8D1CH0010.11110-0.....	381
8D1CH0010.11120-0.....	379
8D1CH0015.11110-0.....	381
8D1CH0015.11120-0.....	379
8D1CH00X5.11110-0.....	381
8DI330.D50450300-1.....	110
8DI440.DB0227700-1.....	109
8ZDFB4000000.000-0.....	374
8ZDFB5000000.000-0.....	375
X67AC0M08.....	378
X67AC0M12.....	378