

ROTEX® GS

Backlash-free jaw couplings

Technical description



ROTEX® GS is a three-part, axial plug-in coupling backlash-free under prestress. It is convincing even with critical applications by its backlash-free power transmission, its stiffness which is each adapted to the application and its optimum damping of vibrations. This principle of installation offers significant assembly possibilities which optimize the assembly times in production.

ROTEX® GS (straight tooth, backlash-free)

The straight spline of the spider mounted under prestress results in a smaller surface pressure and consequently higher stiffness of the coupling system. The flexible teeth compensate for misalignment but are supported radially in the inside diameter by a central web. This avoids too high internal or external deformation by high acceleration or high speeds. This is vital for a smooth operation and long service life of the coupling.

The pegs arranged reciprocally on the spider prevent the spider from touching the hub over the entire surface. Observing the distance dimension E ensures the ability of the coupling to compensate for displacements.

By observing the gap dimension „s“ the electrical insulation is ensured, as well as a high service life of the coupling. This fact is gaining more and more importance, due to the increasing precision of shaft encoders and the existing demand for electro-magnetic compatibility.

Limitation by concave cams in case of too high speeds/centrifugal forces and prestress of elastomer parts

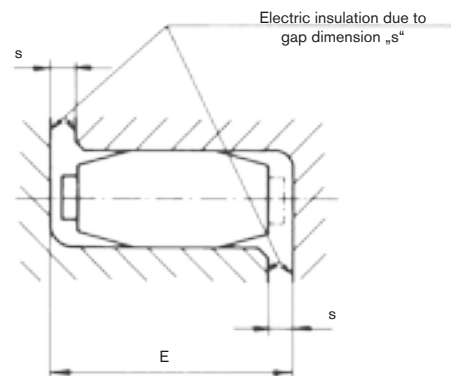
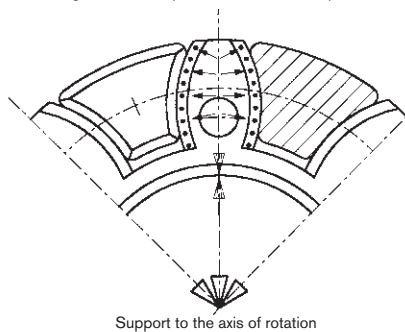

Notes

- Feather keyways available from a bore $\geq \varnothing 6$
- Finish bore tolerance H7 (except for clamping hubs), from $\varnothing 55$ G7 with clamping ring hubs
- Finish bore tolerance H6 for ROTEX® GS P
- Recommended insertion dimension of shafts into the coupling hubs: l_1/l_2 ; for clamping ring hubs l_3
- Spider available with bore on request

Use in explosive applications

ROTEX® GS couplings are suitable for power transmission in drives in hazardous areas. The couplings are certified and confirmed according to EC standard 94/9/EC (ATEX 95) as units of category 2G/2D and thus suitable for the use in hazardous areas of zone 1, 2, 21 and 22. Please read through our information included in the respective Type Examination Certificate and the operating and mounting instructions at www.ktr.com.

Selection: In case of use in hazardous areas the clamping ring hubs (clamping hubs without feather keyway only for use in category 3) must be selected such that there is a minimum safety factor of $s = 2$ between the peak torque (including all operating parameters) and the nominal torque and frictional torque of engagement of the coupling.







ROTEX® GS

Backlash-free jaw couplings

Spiders

The elastic spiders of the GS line are available in five different kinds of Shore hardness, identified by colour, the material being soft to hard. Due to these five spiders with different kinds of Shore hardness it is easily possible to adjust the ROTEX® GS with regard to torsional stiffness and the vibration behaviour to the individual conditions of an application. The flexible prestress varies depending on the coupling size, the spiders/material and the production tolerances. Resulting herefrom is the axial plug-in force starting from low as a close sliding fit or with torsionally soft spider, respectively, to heavy with high prestress or torsionally rigid spider (see mounting instruction KTR-N 45510 at www.ktr.com).

Along with an increasing hardness of the spider the torques to be transmitted and the stiffness of the spider increase, too. Along with a reduced hardness of the spider the ability of compensating for displacements and damping the spider is increased.

Properties						
Description of spider hardness [Shore]	Identification Colour	Material	Perm. temperature range [°C]		Available for coupling size	Typical applications
			Permanent temperature	Max. temperature short-term		
80 Sh-A-GS		Polyurethane	- 50 to + 80	- 60 to + 120	size 5 to 24	- drives of electric measuring systems
92 Sh-A-GS		Polyurethane	- 40 to + 90	- 50 to + 120	size 5 to 55	- drives of electric measuring and control systems - main spindle drives
98-Sh A-GS		Polyurethane	- 30 to + 90	- 40 to + 120	size 5 to 90	- positioning drives - main spindle drives - high load
64 Sh-D-H-GS		Hytrel	- 50 to + 120	- 60 to + 150	size 7 to 38	- planetary gears / backlash-free gears - higher torsion spring stiffness / high ambient temperatures
64 Sh-D-GS		Polyurethane	- 20 to + 110	- 30 to + 120	size 42 to 90	- higher load - higher torsion spring stiffness
72 Sh-D-H-GS		Hytrel	- 50 to + 120	- 60 to + 150	size 24 to 38	- very high torsion spring stiffness / high ambient temperature - very high load
72 Sh-D-GS		Polyurethane	- 20 to + 110	- 30 to + 120	size 42 to 90	- very high torsion spring stiffness - very high load

Degree of hardness

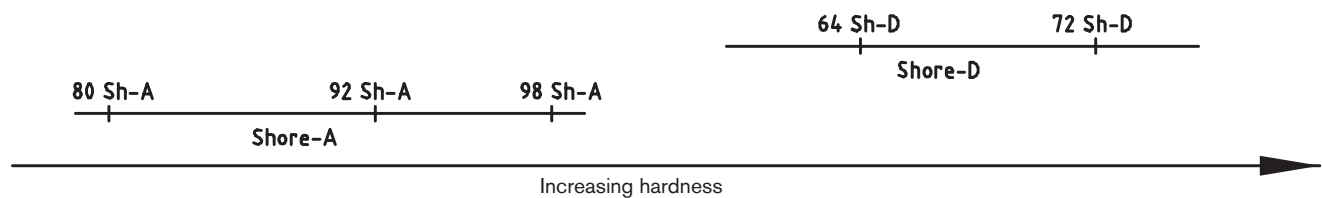

Spider material	Polyurethane			Hytrel
Degree of hardness	92 Shore-A	98 Shore-A	64 Shore-D	64 Shore-D
Relative Damping ψ [-]	0,80	0,80	0,75	0,60
Resonance factor VR [-]	7,90	7,90	8,50	10,5

ROTEX® GS

Backlash-free jaw couplings

Technical data

Size	Spider Shore GS	Shore range	Max. speed [rpm] for type						Torque [Nm]		Static torsion spring stiffness 1) [Nm/rad]	Dynamic torsion spring stiffness 1) [Nm/rad]	Radial spring stiffness Cr [N/mm]	Weight [kg]		Mass moment of inertia J [kgm ²]	
			2.0 / 2.1 2.5 / 2.6	2.8 2.9	1.0 1.1	6.0 light 2)	6.0 P 2)	DKM	TKN	TK max				Each hub 5)	Spider	Each hub 5)	Spider
5	70	A	38000	38000	47700			57300	0,2	0,3	1,78	5	43	0,001	0,2 x 10 ⁻³	0,015 x 10 ⁻⁶	0,002 x 10 ⁻⁶
	80	A							0,3	0,6	3,15	10	82				
	92	A							0,5	1,0	5,16	16	154				
	98	A							0,9	1,7	8,3	25	296				
7	80	A	27000	27000	34100			40900	0,7	1,4	8,6	26	114	0,003	0,5 x 10 ⁻³	0,085 x 10 ⁻⁶	0,01 x 10 ⁻⁶
	92	A							1,2	2,4	14,3	43	219				
	98	A							2,0	4,0	22,9	69	421				
	64	D							2,4	4,8	34,3	103	630				
8	80	A	23800						0,7	1,4	8,8	27	117	0,003	3 x 10 ⁻³	0,117 x 10 ⁻⁶	0,01 x 10 ⁻⁶
	98	A							2,0	4,0	23,5	71	433				
	64	D							2,4	4,8	35,3	106	648				
9	80	A	19000	19000	23800			28600	1,8	3,6	17,2	52	125	0,01	1,7 x 10 ⁻³	0,48 x 10 ⁻⁶	0,085 x 10 ⁻⁶
	92	A							3,0	6,0	31,5	95	262				
	98	A							5,0	10,0	51,6	155	518				
	64	D							6,0	12,0	74,6	224	739				
12	80	A	15200	15200	19100			22900	3,0	6,0	84,3	252	274	0,02	2,3 x 10 ⁻³	1,5 x 10 ⁻⁶	0,139 x 10 ⁻⁶
	92	A							5,0	10,0	160,4	482	470				
	98	A							9,0	18,0	240,7	718	846				
	64	D							12,0	24,0	327,9	982	1198				
13	80	A	12700						3,6	7,2	111	330	359	0,01	1,3 x 10 ⁻³	1,1 x 10 ⁻⁶	0,155 x 10 ⁻⁶
	98	A							11,0	22,0	316	941	1109				
	64	D							14,5	29,0	430	1287	1570				
14	80	A	12700	12700	15900	32000	47700	19100	4,0	8,0	60,2	180	153	0,02	4,7 x 10 ⁻³	2,8 x 10 ⁻⁶	0,509 x 10 ⁻⁶
	92	A							7,5	15,0	114,6	344	336				
	98	A							12,5	25,0	171,9	513	654				
	64	D							16,0	32,0	234,2	702	856				
16	80	A	12000						5,0	10,0	157	471	400	0,02	2,3 x 10 ⁻³	2,8 x 10 ⁻⁶	0,434 x 10 ⁻⁶
	98	A							15,0	30,0	450	1341	1710				
	64	D							19,0	38,0	612	1835	2238				
	80	A							6,0	12,0	618	1065	582				
19	92	A	9550	9550	11900	24000	35800	14300	12,0	24,0	1090	1815	1120	0,09	7 x 10 ⁻³	19,5 x 10 ⁻⁶	1,35 x 10 ⁻⁶
	98	A							21,0	42,0	1512	2540	2010				
	64	D							26,0	52,0	2560	3810	2930				
	80	A							35	70	2280	4010	1480				
24	98	A	6950	10400	8650	17000	26000	10400	60	120	3640	5980	2560	0,2	0,02	81,9 x 10 ⁻⁶	6,7 x 10 ⁻⁶
	64	D							75	150	5030	10896	3696				
	72 ³⁾	D							97	194	9944	17095	5799				
	92	A							95	190	4080	6745	1780				
28	98	A	5850	8800	7350	15000	22000	8800	160	320	6410	9920	3200	0,3	0,03	184,2 x 10 ⁻⁶	14,85 x 10 ⁻⁶
	64	D							200	400	10260	20177	4348				
	72 ³⁾	D							260	520	21526	36547	7876				
	92	A							190	380	6525	11050	2350				
38	98	A	4750	7150	5950	12000	17900	7150	325	650	11800	17160	4400	0,6	0,05	542,7 x 10 ⁻⁶	39,4 x 10 ⁻⁶
	64	D							405	810	26300	40335	6474				
	72 ³⁾	D							525	1050	44584	71180	11425				
	92	A							265	530	10870	15680	2430				
42	98	A	4000		5000	10000 8050 ⁴⁾	15000	6000	450	900	21594	37692	5570	2,4	0,08	2802 x 10 ⁻⁶	85 x 10 ⁻⁶
	64	D							560	1120	36860	69825	7270				
	72 ³⁾	D							728	1456	58600	93800	9766				
	92	A							310	620	12968	18400	2580				
48	98	A	3600		4550	9100 7200 ⁴⁾	13600	5450	525	1050	25759	45620	5930	3,3	0,09	4709 x 10 ⁻⁶	135 x 10 ⁻⁶
	64	D							655	1310	57630	99750	8274				
	72 ³⁾	D							852	1704	80000	136948	11359				
	92	A							410	820	15482	21375	2980				
55	98	A	3150		3950	6350 ⁴⁾	11900	4750	685	1370	42117	61550	6686	5,1	0,12	9460 x 10 ⁻⁶	229 x 10 ⁻⁶
	64	D							825	1650	105730	130200	9248				
	72 ³⁾	D							1072	2144	150000	209530	12762				
	98	A							940	1880	48520	71660	6418				
65	64	D	2800		3500	5650 ⁴⁾	11000		1175	2350	118510	189189	8870	6,7	0,2	15143 x 10 ⁻⁶	437 x 10 ⁻⁶
	72 ³⁾	D							1527	3054	160000	310000	11826				
	98	A							1920	3840	79150	150450	8650				
75	64	D	2350		2950	4750 ⁴⁾	8950		2400	4800	182320	316377	11923	10,5	0,3	32750 x 10 ⁻⁶	1179 x 10 ⁻⁶
	72 ³⁾	D							3120	6240	360540	586429	16454				
	98	A							3600	7200	204500	302900	10700				
90	64	D	1900		2380	3800 ⁴⁾	7150		4500	9000	429450	908700	14700	18,2	0,6	87099 x 10 ⁻⁶	3362 x 10 ⁻⁶
	72 ³⁾	D							5850	11700	847440	1308852	20290				

1) Static and dynamic torsion spring stiffness with 0,5 x TKN

2) Higher speeds on request

3) With the use of the 72Sh-D spider we recommend to use hubs made of steel

4) Clamping ring hubs 6.0 made of steel

5) Hubs with an average bore type 1.0

The coupling has to be dimensioned in a way that the permissible coupling load is not exceeded with any operating condition. (see coupling selection on page 18 et seqq.)

The torques TKN/TKmax specified refer to the spider. The shaft-hub-connection has to be investigated by the customer.

ROTEX® GS

Backlash-free jaw couplings

Notes for displacements

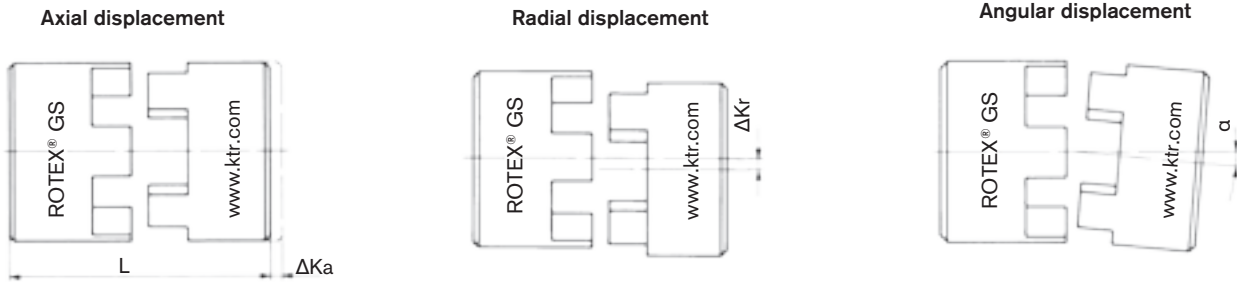

Due to its design the ROTEX® GS is able to absorb axial, angular and radial displacement, without causing any wear or premature failure of the coupling. As the spider is only stressed under pressure it is ensured that the coupling will remain backlash-free even after a longer operation period.

As an example, axial displacement may be produced by different tolerances of the connecting elements during the assembly or by alteration of the shaft length if fluctuation of temperature occurs. As the shaft bearings usually cannot be axially stressed to a big extent, it is the task of the coupling to compensate for this axial displacement and to keep the reaction forces low.

In case of pure angular displacement the imagined bisecting lines of the shafts intersect in the middle of the coupling. Up to a certain permissible extent this displacement can be absorbed by the coupling without any danger of extensive restoring forces.

Radial displacement results from parallel displacement of the shafts towards each other, caused by different tolerances at the centerings or by mounting of the power packs on different levels. Due to the kind of displacement the largest restoring forces are produced here, consequently causing the highest stresses for the adjacent components.

In case of larger displacements (especially radial displacements) the ROTEX® GS DKM double-cardanic design should be applied in order to avoid excessive restoring forces.

The above-mentioned permissible displacement figures of the flexible ROTEX® GS couplings are standard values, considering the coupling load up to the rated torque TKN of the coupling and with an ambient temperature of + 30 °C. The ROTEX® GS couplings are in a position to compensate for radial and angular displacements. Careful and accurate alignment of the shafts increases the service life of the coupling.

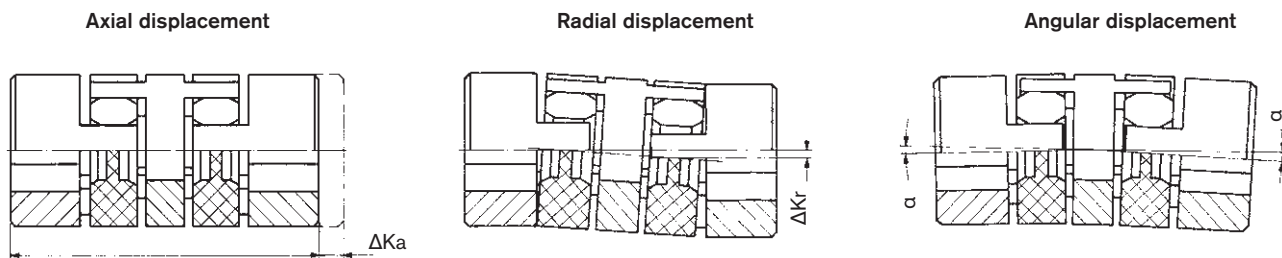

Shaft misalignment ROTEX® GS type DKM

This design reduces the restoring forces arising with radial displacement to a minimum, due to the double-jointed operation, additionally the coupling is able to compensate for higher axial and angular misalignment.

ROTEX® GS

Backlash-free jaw couplings

Displacements

Displacements							
Size	Spider GS	Displacements standard			Displacements DKM		
		[mm] axial $\Delta K_a^{1)}$	[mm] radial ΔK_r	[degree] angular α	[mm] axial $\Delta K_a^{1)}$	[mm] radial ΔK_r	[degree] angular α
5	70 Sh-A		0,14	1,2°		0,17	1,2°
	80 Sh-A	+0,4	0,12	1,1°	+0,4	0,15	1,1°
	92 Sh-A	-0,2	0,06	1,0°	-0,4	0,14	1,0°
	98 Sh-A		0,04	0,9°		0,13	0,9°
7	80 Sh-A		0,15	1,1°		0,23	1,1°
	92 Sh-A	+0,6	0,10	1,0°	+0,6	0,21	1,0°
	98 Sh-A	-0,3	0,06	0,9°	-0,6	0,19	0,9°
	64 Sh-D		0,04	0,8°		0,17	0,8°
8	80 Sh-A		0,15	1,1°			
	98 Sh-A	± 1	0,08	0,9°	—	—	—
	64 Sh-D		0,06	0,8°			
9	80 Sh-A		0,19	1,1°		0,29	1,1°
	92 Sh-A	+0,8	0,13	1,0°	+0,8	0,26	1,0°
	98 Sh-A	-0,4	0,08	0,9°	-0,8	0,24	0,9°
	64 Sh-D		0,05	0,8°		0,21	0,8°
12	80 Sh-A		0,20	1,1°		0,35	1,1°
	92 Sh-A	+0,9	0,14	1,0°	+0,9	0,32	1,0°
	98 Sh-A	-0,4	0,08	0,9°	-0,9	0,29	0,9°
	64 Sh-D		0,05	0,8°		0,25	0,8°
13	80 Sh-A		0,20	1,1°			
	98 Sh-A	± 1	0,08	0,9°	—	—	—
14	80 Sh-A		0,21	1,1°		0,40	1,1°
	92 Sh-A	+1,0	0,15	1,0°	+1,0	0,37	1,0°
	98 Sh-A	-0,5	0,09	0,9°	-1,0	0,33	0,9°
	64 Sh-D		0,06	0,8°		0,29	0,8°
16	80 Sh-A		0,21	1,1°			
	98 Sh-A	± 1	0,10	0,9°	—	—	—
	64 Sh-D		0,08	0,8°			
19	80 Sh-A		0,15	1,1°		0,49	1,1°
	92 Sh-A	+1,2	0,10	1,0°	+1,2	0,45	1,0°
	98 Sh-A	-0,5	0,06	0,9°	-1,0	0,41	0,9°
	64 Sh-D		0,04	0,8°		0,36	0,8°
24	92 Sh-A		0,14	1,0°		0,59	1,0°
	98 Sh-A	+1,4	0,10	0,9°	+1,4	0,53	0,9°
	64 Sh-D	-0,5	0,07	0,8°	-1,0	0,47	0,8°
	72 Sh-D		0,04	0,7°		0,42	0,7°
28	92 Sh-A		0,15	1,0°		0,66	1,0°
	98 Sh-A	+1,5	0,11	0,9°	+1,5	0,60	0,9°
	64 Sh-D	-0,7	0,08	0,8°	-1,4	0,53	0,8°
	72 Sh-D		0,05	0,7°		0,46	0,7°
38	92 Sh-A		0,17	1,0°		0,77	1,0°
	98 Sh-A	+1,8	0,12	0,9°	+1,8	0,69	0,9°
	64 Sh-D	-0,7	0,09	0,8°	-1,4	0,61	0,8°
	72 Sh-D		0,06	0,7°		0,54	0,7°
42	92 Sh-A		0,19	1,0°		0,84	1,0°
	98 Sh-A	+2,0	0,14	0,9°	+2,0	0,75	0,9°
	64 Sh-D	-1,0	0,10	0,8°	-2,0	0,67	0,8°
	72 Sh-D		0,07	0,7°		0,59	0,7°
48	92 Sh-A		0,23	1,0°		0,91	1,0°
	98 Sh-A	+2,1	0,16	0,9°	+2,1	0,82	0,9°
	64 Sh-D	-1,0	0,11	0,8°	-2,0	0,73	0,8°
	72 Sh-D		0,08	0,7°		0,64	0,7°
55	92 Sh-A		0,24	1,0°		1,01	1,0°
	98 Sh-A	+2,2	0,17	0,9°	+2,2	0,91	0,9°
	64 Sh-D	-1,0	0,12	0,8°	-2,0	0,81	0,8°
	72 Sh-D		0,09	0,7°		0,71	0,7°
65	98 Sh-A	+2,6	0,18	0,9°			
	64 Sh-D	-1,0	0,13	0,8°	—	—	—
	72 Sh-D		0,10	0,7°			
75	98 Sh-A	+3,0	0,21	0,9°			
	64 Sh-D	-1,5	0,15	0,8°	—	—	—
	72 Sh-D		0,11	0,7°			
90	98 Sh-A	+3,4	0,23	0,9°			
	64 Sh-D	-1,5	0,17	0,8°	—	—	—
	72 Sh-D		0,13	0,7°			

¹⁾ The Ka figures mentioned above have to be added to the length of the respective coupling type.

ROTEX® GS

Backlash-free jaw couplings

Displacements of intermediate shaft coupling

Displacements of intermediate shaft coupling			
ROTEX® GS size with 98 Sh-A-GS	Axial ΔK_a [mm]	Radial ΔK_r ¹⁾ [mm]	Angular α [degree]
14	+1,0	15	0,9°
	-1,0		
19	+1,2	14	0,9°
	-1,0		
24	+1,4	14	0,9°
	-1,0		
28	+1,5	14	0,9°
	-1,4		
38	+1,8	14	0,9°
	-1,4		
42	+2,0	14	0,9°
	-2,0		
48	+2,1	13	0,9°
	-2,0		
55	+2,2	13	0,9°
	-2,0		
65	+2,6	13	0,9°
	-2,0		

1) Radial displacements based on a coupling length $LZR = 1000$ mm

Calculation of overall torsion spring stiffness:

$$C_{ges.} = 2 \cdot \frac{1}{C_1} + \frac{L_{pipe}}{C_2} \quad [\text{Nm/rad}]$$

$$\text{with } L_{pipe} = \frac{LZR - 2 \cdot L}{1000} \quad [\text{m}]$$

C_1 = torsion spring stiffness for spider see page 120
 C_2 = from table on page 140-143

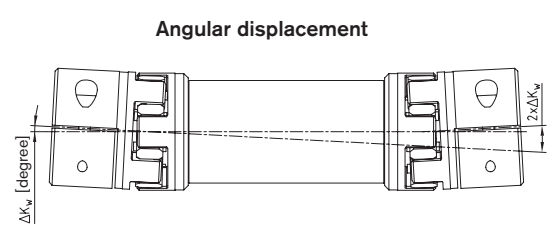
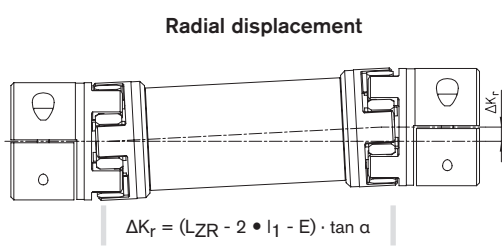
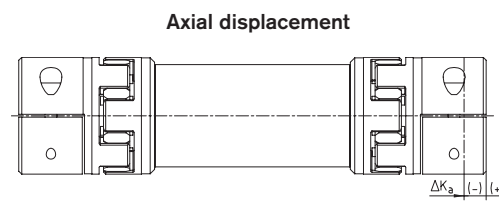
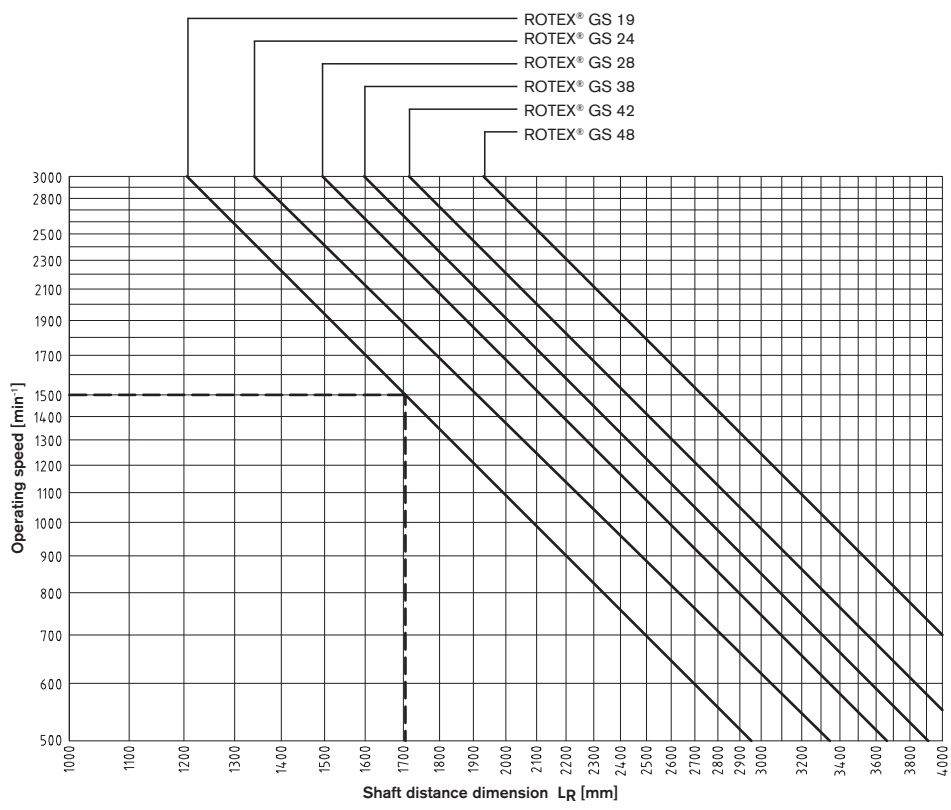

Chart of critical bending speeds for type ZR3



Example:
 ROTEX® GS 19
 Operating speed: 1500 min⁻¹
 Max. permissible shaft distance dimension: 1700 mm
 Operating speed = $n_{krit}/1,4$

ROTEX® GS

Backlash-free jaw couplings

Hub types

Due to the numerous applications of ROTEX® GS for many different mounting situations, this coupling system is available with various hub types. The different hub types can be combined optionally within one size.



Type 1.0 with feather keyway and setscrew

Positive locking power transmission, permissible torque depending on the permissible surface pressure. Not suitable for backlash-free power transmission with heavily reversing operation.

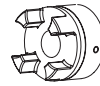

Type 1.1 without keyway, with setscrew

Non-positive torque transmission, suitable for backlash-free transmission of very small torques. (For ATEX category 3 only)

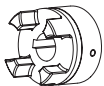

Type 2.0 clamping hub, single slotted, without feather keyway

Frictionally engaged, backlash-free shaft-hub-connection. Transmittable torques depending on bore diameter Type 2.0 up to size 14 as standard. (For ATEX category 3 only)



Type 2.1 clamping hub, single slotted, with feather keyway

Positive locking power transmission with additional frictionally engaged condition. The frictionally engaged condition prevents or reduces reverse backlash, respectively. Surface pressure of the keyway connection is reduced. Type 2.1 up to size 14 as standard.



Type 2.5 Clamping hub double slot, without feather keyway

Frictionally engaged, backlash-free shaft-hub-connection. Transmittable torques depending on bore diameter Type 2.5 from size 19 as standard. (For ATEX category 3 only)



Type 2.6 Clamping hub double slot, with feather keyway

Positive locking power transmission with additional frictionally engaged condition. The frictionally engaged condition prevents or reduces reverse backlash, respectively. Surface pressure of the keyway connection is reduced. Type 2.5 from size 19 as standard.



Type 2.8 short clamping hub C with axial slots without feather keyway

Frictionally engaged, backlash-free shaft-hub-connection, good properties of concentric running. Transmittable torques depending on bore diameter Type 2.8 from size 24 as standard. Size 7-19 type 2.8 single slotted (for ATEX cat. 3 only)

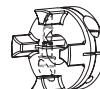

Type 2.9 short clamping hub C with axial slots with feather keyway

Positive locking power transmission with additional frictionally engaged condition. Surface pressure of the keyway connection is reduced. Type 2.9 from size 24 as standard, size 7-19 type 2.9 single slotted.



Type 6.0 Clamping ring hub

Integrated frictionally engaged shaft-hub-connection for the transmission of higher torques. Screwing on elastomer side. For details about torque and dimensions see page 156/157. Suitable for high speeds.



Type 6.0 P Precision clamping ring hub

Operating principle equal to type 6.0, but highly accurate machining with slight modifications of design, see page 132.



Type Design 7.5 clamping hub type DH without feather keyway for double-cardanic connections

Frictionally engaged, backlash-free shaft-hub-connection for radial assembly of coupling. Transmittable torques depending on bore diameter For torques see page 140.



Type 7.6 clamping hub type DH with feather keyway for double-cardanic connections

Positive shaft-hub connection with additional frictional engagement for the radial assembly of the coupling. The frictional engagement avoids or reduces the reverse backlash. Surface pressure of the keyway connection is reduced.



Type 7.8 clamping hub type H without feather keyway, single-cardanic connection



Type 7.9 clamping hub type H with feather keyway for single-cardanic connection



Type 4.2 with CLAMPEX® KTR 250

Frictionally engaged shaft-hub-connection to transmit high torques with clamping screws externally

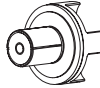

Type 9.0 expansion hub

Frictionally engaged connection for hollow shaft. Transmittable torques depend on the bore diameter and the hollow shaft.

Special designs on request of customers



Type 6.5 Clamping ring hub

Design equal to 6.0, but clamping screws on the outside. As an example for radial disassembly of intermediate pipe (special design).

ROTEX® GS

Backlash-free jaw couplings

Stock programme

		Finish bore [mm] according to ISO fit H7 / feather keyway with thread according to DIN 6885 sheet 1 - JS9																																				
Size	Hub type	Un-/pilot bored	Ø2	Ø3	Ø4	Ø5	Ø6	Ø6,35	Ø7	Ø8	Ø9	Ø9,5	Ø10	Ø11	Ø12	Ø14	Ø15	Ø16	Ø18	Ø19	Ø20	Ø22	Ø24	Ø25	Ø28	Ø30	Ø32	Ø35	Ø38	Ø40	Ø42	Ø45						
7	1.1	●			●	●	●																															
	2.0	●		●	●	●	●	●	●																													
	2.8	●																																				
8	2.8	●			●	●				●																												
	1.0	●				●				●	●			●																								
9	1.1	●			●	●	●			●	●			●																								
	2.0	●		●	●	●	●	●	●	●	●			●	●																							
	2.1	●					●			●	●			●																								
	2.8	●																																				
12	1.0	●													●																							
	2.0	●			●	●	●	●		●	●			●	●																							
	2.1	●													●																							
13	2.8	●								●				●																								
	1.0	●				●				●	●			●	●	●	●	●	●	●	●	●	●	●	●	●	●	●	●	●	●	●	●	●				
14	1.1	●				●				●	●			●	●	●	●	●	●	●	●	●	●	●	●	●	●	●	●	●	●	●	●	●	●			
	2.0	●			●	●	●	●	●	●	●			●	●	●	●	●	●	●	●	●	●	●	●	●	●	●	●	●	●	●	●	●	●			
	2.1	●								●	●			●	●	●	●	●	●	●	●	●	●	●	●	●	●	●	●	●	●	●	●	●	●	●		
16	2.8	●								●				●																								
	1.0	●								●	●			●	●	●	●	●	●	●	●	●	●	●	●	●	●	●	●	●	●	●	●	●	●	●		
19	2.5	●				■				●			●	●	●	●	●	●	●	●	●	●	●	●	●	●	●	●	●	●	●	●	●	●	●			
	2.6	●								●			●	●	●	●	●	●	●	●	●	●	●	●	●	●	●	●	●	●	●	●	●	●	●	●		
	2.8	●								●	●			●	●	●	●	●	●	●	●	●	●	●	●	●	●	●	●	●	●	●	●	●	●	●		
	6.0 light													●	●	●	●	●	●	●	●	●	●	●	●	●	●	●	●	●	●	●	●	●	●	●		
	6.0 P																																				●	
24	1.0	●								●	●			●	●	●	●	●	●	●	●	●	●	●	●	●	●	●	●	●	●	●	●	●	●	●		
	2.5	●								■				●	●	●	●	●	●	●	●	●	●	●	●	●	●	●	●	●	●	●	●	●	●	●	●	
	2.6	●													●	●	●	●	●	●	●	●	●	●	●	●	●	●	●	●	●	●	●	●	●	●	●	
	2.8	●														●	●	●	●	●	●	●	●	●	●	●	●	●	●	●	●	●	●	●	●	●	●	
	6.0 light														●																							
28	6.0 steel																																					
	6.0 P																																					
	1.0	●																																				
	2.5	●																																				
	2.6	●																																				
38	2.8	●																																				
	6.0 light																																					
	6.0 steel																																					
	6.0 P																																					
	1.0	●																																				
42	2.5	●																																				
	2.6	●																																				
	2.8	●																																				
	6.0 light																																					
48	6.0 steel																																					
	6.0 steel																																					
55	6.0 steel																																					
65	6.0 steel																																					
75	6.0 steel																																					
90	6.0 steel																																					

Taper bores for Fanuc motors:
 GS 19 1:10 Ø 11
 GS 24 1:10 Ø 16

		Finish bores [mm]														
Size	Hub type	Ø28	Ø30	Ø32	Ø35	Ø38	Ø40	Ø42	Ø45	Ø48	Ø50	Ø55	Ø60	Ø65	Ø70	Ø80
42	6.0 light	●		●	●	●		●	●		●					
	6.0 steel	●	●	●	●	●	●	●	●	●	●					
48	6.0 light			●	●	●	●	●	●	●	●					
	6.0 steel			●	●	●	●	●	●	●	●	●				
55	6.0 steel					●	●	●	●	●	●	●	●			
65	6.0 steel						●	●	●	●	●	●	●	●		
75	6.0 steel							●	●	●	●	●	●	●	●	●
90	6.0 steel											●	●	●	●	●

■ = Pilot bored clamping hubs
 ● = Standard bore from stock
 Unbored hubs up to size 65 available from stock.
 Other dimensions on request

ROTEX® GS

Backlash-free jaw couplings

Standard types



For legend of pictogram please refer to flapper on the cover

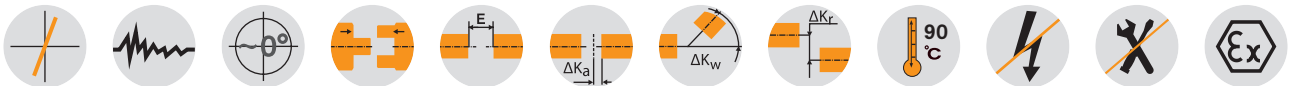

ROTEX® GS 5 - 38

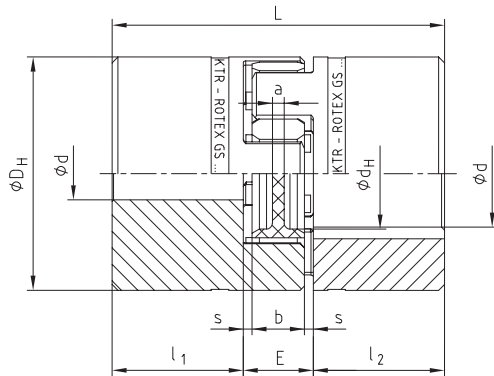

ROTEX® GS 42 - 90

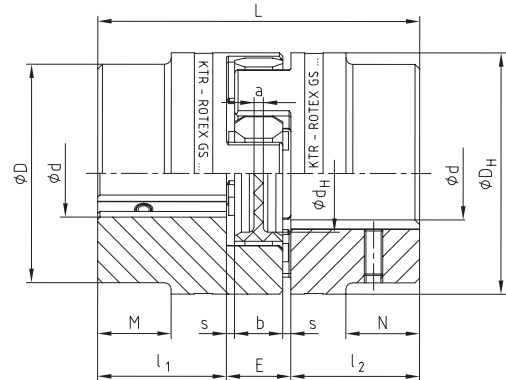

Hub types:

Type 1.0

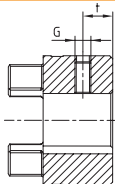

with keyway
and set screw

Type 1.1

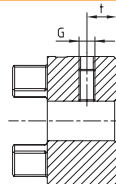

without keyway and with
set screw

Type 1.2

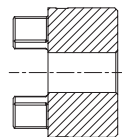

without keyway and
without set screw

ROTEX® GS standard types For size 5 to 38 hub material aluminium/for size 42 to 90 hub material steel

Size	Spider torque T _{KN} [Nm] for 98Sh-A ¹⁾	Maximum finish bore Ød for hub type			Dimensions [mm]										Setscrew DIN EN ISO 4029 hub type 1.0/1.1		
		1.0	1.1	1.2	D	D _H	d _H	L	l ₁ :l ₂	M:N	E	b	s	a	G	t	T _A
5	0,9	-	6	5	-	10	-	15	5	-	5	4	0,5	4,0	M2	2,5	0,2
7	2,0	7	7	7	-	14	-	22	7	-	8	6	1,0	6,0	M3	3,5	0,3
9	5,0	10	11	11	-	20	7,2	30	10	-	10	8	1,0	1,5	M4	5,0	1,5
12	9,0	12	12	12	-	25	8,5	34	11	-	12	10	1,0	3,5	M4	5,0	1,5
14	12,5	16	16	16	-	30	10,5	35	11	-	13	10	1,5	2,0	M4	5,0	1,5
19	21	24	-	-	-	40	18	66	25	-	16	12	2,0	3,0	M5	10	2,0
24	60	28	-	-	-	55	27	78	30	-	18	14	2,0	3,0	M5	10	2,0
28	160	38	-	-	-	65	30	90	35	-	20	15	2,5	4,0	M8	15	10
38	325	45	-	-	-	80	38	114	45	-	24	18	3,0	4,0	M8	15	10
42	450	55	-	-	85	95	46	126	50	28	26	20	3,0	4,0	M8	20	10
48	525	62	-	-	95	105	51	140	56	32	28	21	3,5	4,0	M8	20	10
55	685	74	-	-	110	120	60	160	65	37	30	22	4,0	4,5	M10	20	17
65	940	80	-	-	115	135	68	185	75	47	35	26	4,5	4,5	M10	20	17
75	1920	95	-	-	135	160	80	210	85	53	40	30	5,0	5,0	M10	25	17
90	3600	110	-	-	160	200	104	245	100	62	45	34	5,5	6,5	M12	30	40

¹⁾ Other spiders/selection see page 142/143

Ordering example:	ROTEX® GS 24	98 Sh-A-GS	d20	2.5 - Ø 24		1.0 - Ø 20	
	Coupling size	Spider hardness	Optional: Bore in spider	Hub type	Finish bore	Hub type	Finish bore

Hub types:

Type 2.0
Type 2.1

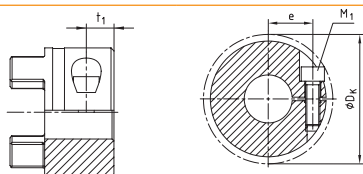

size 5 to 14
Type 2.0: Single slotted clamping hub without feather keyway (only for ATEX cat. 3), torque depending on bore Ø.
Type 2.1: single slotted clamping hub with feather keyway

Type 2.5
Type 2.6

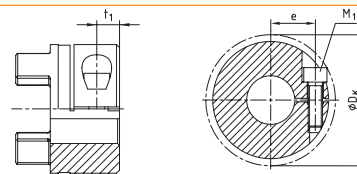

from size 19
Type 2.5: double slotted clamping hub without feather keyway (only for ATEX cat. 3), torque depending on bore Ø.
Type 2.6: double slotted clamping hub with feather keyway

ROTEX® GS standard types For size 5 to 38 hub material aluminium/for size 42 to 90 hub material steel

Size	Spider torque T _{KN} [Nm] for 98Sh-A ¹⁾	Maximum finish bore Ød for hub type				Dimensions [mm]													Clamping screw DIN EN ISO 4762 (ROTEX® 5 DIN 84) hub type 2.0/2.1/2.5/2.6				
		2.0	2.1	2.5	2.6	D	D _H	d _H	L	l _{1,2}	M;N	E	b	s	a	M ₁	t ₁	e	D _K	T _A [Nm]			
5	0,9	5	5	-	-	-	10	-	15	5	-	5	4	0,5	4,0	M1,2	2,5	3,5	11,4	- ²⁾			
7	2,0	7	7	-	-	-	14	-	22	7	-	8	6	1,0	6,0	M2	3,5	5,0	16,5	0,37			
9	5,0	11	11	-	-	-	20	7,2	30	10	-	10	8	1,0	1,5	M2,5	5,0	7,5	23,4	0,76			
12	9,0	12	12	-	-	-	25	8,5	34	11	-	12	10	1,0	3,5	M3	5,0	9,0	27,5	1,34			
14	12,5	16	16	-	-	-	30	10,5	35	11	-	13	10	1,5	2,0	M3	5,0	11,5	32,2	1,34			
19	21	-	-	24	24	-	40	18	66	25	-	16	12	2,0	3,0	M6	11,0	14,5	46	10,5			
24	60	-	-	28	28	-	55	27	78	30	-	18	14	2,0	3,0	M6	10,5	20,0	57,5	10,5			
28	160	-	-	38	38	-	65	30	90	35	-	20	15	2,5	4,0	M8	11,5	25,0	73	25			
38	325	-	-	45	45	-	80	38	114	45	-	24	18	3,0	4,0	M8	15,5	30,0	83,5	25			
42	450	-	-	50	45	85	95	46	126	50	28	26	20	3,0	4,0	M10	18	32,0	93,5	69			
48	525	-	-	55	55	95	105	51	140	56	32	28	21	3,5	4,0	M12	21	36,0	105	120			
55	685	-	-	68	68 ³⁾	110	120	60	160	65	37	30	22	4,0	4,5	M12	26	42,5	119,5	120			
65	940	-	-	70	70 ³⁾	115	135	68	185	75	47	35	26	4,5	4,5	M12	33	45,0	124	120			
75	1920	-	-	80	80	135	160	80	210	85	53	40	30	5,0	5,0	M16	36	51,0	147,5	295			
90	3600	-	-	90	90	160	200	104	245	100	62	45	34	5,5	6,5	M20	40	60,0	192	580			

¹⁾ Other spiders/selection see page 18 et seqq.

²⁾ No T_A defined (slotted screw)

³⁾ From Ø60 keyway opposite to the clamping screw

⁴⁾ Clamping hub single slotted with 2-off clamping screws M4 and dimension e=15

Review of shaft-hub-connection: Friction torques for hub type 2.0

Size	Ø2	Ø3	Ø4	Ø5	Ø6	Ø7	Ø8	Ø9	Ø10	Ø11	Ø12	Ø14	Ø15	Ø16
7		0,8	0,9	0,95	1,0	1,1								
9			2,1	2,2	2,3	2,4	2,5	2,6	2,7	2,8				
12			3,6	3,8	4,0	4,1	4,3	4,5	4,7	4,8	5,0			
14				4,7	4,8	5,0	5,1	5,3	5,5	5,6	5,8	6,1	6,3	6,5

Review of shaft-hub-connection: Friction torques for hub type 2.5

Size	Ø8	Ø10	Ø11	Ø14	Ø15	Ø16	Ø18	Ø19	Ø20	Ø22	Ø24	Ø25	Ø28	Ø30	Ø32	Ø35	Ø38	Ø40	Ø42	Ø45	Ø48	Ø50	Ø55	Ø60	Ø65	Ø70	Ø75	Ø80	Ø90
19	25	27	27	29	30	31	32	32	34	30 ⁴⁾	32 ⁴⁾																		
24		34	35	36	38	38	39	40	41	42	43	45	46																
28				80	81	81	84	85	87	89	91	92	97	99	102	105	109												
38				92	94	97	98	99	102	104	105	109	112	113	118	122	123	126	130										
42									232	238	244	246	255	260	266	274	283	288	294	301	309	315							
48												393	405	413	421	434	445	454	462	473	486	494	514						
55															473	486	498	507	514	526	539	547	567	587	608				
65															507	518	526	535	547	559	567	587	608	627	648				
75																		1102	1124	1148	1163	1201	1239	1278	1316	1354	1393		
90																		1944	1980	2016	2040	2100	2160	2220	2280	2340	2400	2520	

ROTEX® GS Compact

Backlash-free jaw couplings

Compact design



For legend of pictogram please refer to flapper on the cover

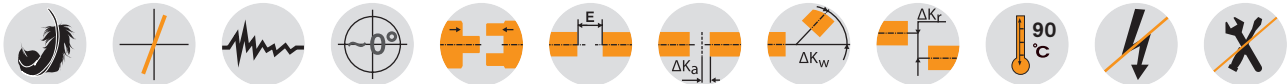

ROTEX® GS Compact																		
Size	Spider torque T_{KN} [Nm] ¹⁾				Dimensions [mm]													T_A [Nm]
	80Sh-A	92Sh-A	98Sh-A	64Sh-D	maximum d	D _H	D _K	L	l ₁ , l ₂	E	b	s	d _H	t	e	M		
Single slotted hub design 2.8/2.9																		
7	0,7	1,2	2,0	2,4	7	14	16,6	18	5	8	6	1	-	2,5	5	M2	0,37	
8	0,5	-	2,0	2	8	16	17,1	20	7	6	5	0,5	6,2	4	5,5	M2	0,52	
9	1,8	3,0	5,0	6	9	20	21,3	24	7	10	8	1	-	3,5	6,7	M2,5	0,76	
12	3,0	5,0	9,0	12	12	25	26,2	26	7	12	10	1	-	3,5	8,3	M3	1,34	
13	3,6	-	11	14,5	12,7	25	25,7	26	8	10	8	1	10	4	8	M3	1,9	
14	4,0	7,5	12,5	16	16 ²⁾	30	30,5	32	9,5	13	10	1,5	-	4,5	9,6	M4	2,9	
16	5,0	-	15	19	16	30	32,5	32	10,3	11,4	9,4	1	14	5,3	10,5	M4	4,1	
19	6,0	12,0	21,0	26,0	24 ²⁾	40	45,0	50	17	16	12	2	-	9	14,0	M6	10	
Axially slotted hub design 2.8/2.9																		
24	-	35	60	75	32	55	57,5	54	18	18	14	2	-	11	20,0	M6	10	
28	-	95	160	200	35	65	69,0	62	21	20	15	2,5	-	12	23,8	M8	25	
38	-	190	325	405	45	80	86,0	76	26	24	18	3	-	16	30,5	M10	49	

Review of shaft-hub-connection: Friction torques for hub type 2.8																											
Size	Ø3	Ø4	Ø5	Ø6	Ø7	Ø8	Ø9	Ø10	Ø11	Ø12	Ø14	Ø15	Ø16	Ø18	Ø19	Ø20	Ø24	Ø25	Ø28	Ø30	Ø32	Ø35	Ø38	Ø40	Ø42	Ø45	
Single slotted hub design 2.8																											
7	0,8	0,9	1,0	1,0	1,1																						
8	0,65	0,85	1,1	1,3	1,5	1,7																					
9		1,9	2,0	2,1	2,2	2,3	2,4																				
12		3,4	3,6	3,7	3,9	4,1	4,2	4,4	4,6	4,7																	
13		2,2	2,75	3,3	3,8	4,4	4,9	5,5	6	6,6																	
14			7,1	7,4	7,7	8,0	8,2	8,5	8,8	9,1	5,8 ²⁾	5,9 ²⁾	6,1 ²⁾														
16			4,8	5,8	6,4	7,7	8,7	9,6	11,6	11,5	13,5	14,5	15,4														
19						24,3	25,0	25,7	26,3	27,0	28,4	29,0	29,7	31,1	31,7	32,4	25,0 ²⁾										
Axially slotted hub design 2.8																											
24								21	23	25	30	32	34	38	40	42	51	53	59	63	68						
28											54	58	62	70	74	78	93	97	109	116	124	136					
38											92	99	111	117	123	148	154	173	185	197	216	234	247	259	278		

¹⁾ Other spiders/selection see page 18 et seqq.

²⁾ Size 14 with screw M3 and dimension e=10.4, size 19 with screw M5 and dimension e=15.5

2.8 = Without feather keyway

2.9 = With feather keyway

Ordering example:	ROTEX® GS 38	Compact	98 Sh-A-GS	d28	2.8 - Ø28		2.8 - Ø45	
	Coupling size	Type	Spider hardness	Optional Bore in spider	Hub type	Finish bore	Hub type	Finish bore

ROTEX® GS 8, 13, 16
Compact
Single slotted type 2.8

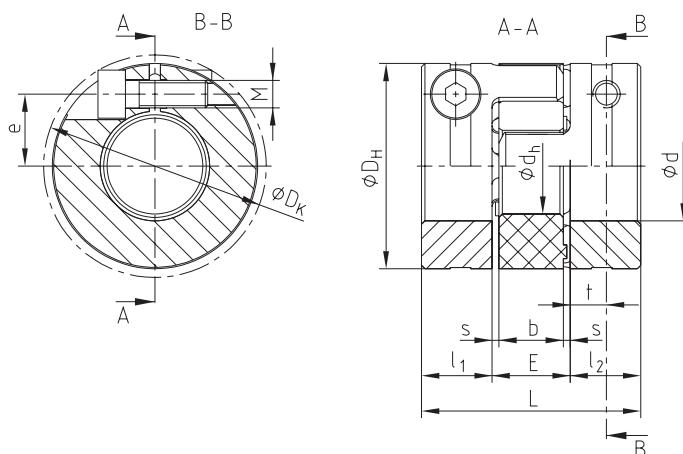

ROTEX® GS 7, 9, 12, 14, 19
Compact
Single slotted type 2.8

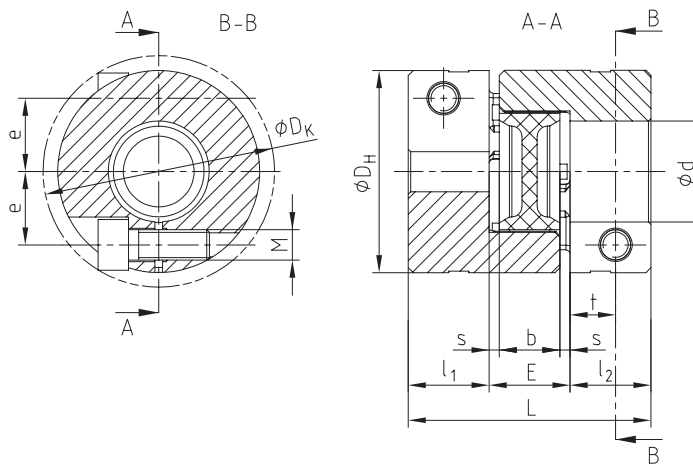

ROTEX® GS 24 - 38 Compact
Axially slotted type 2.8

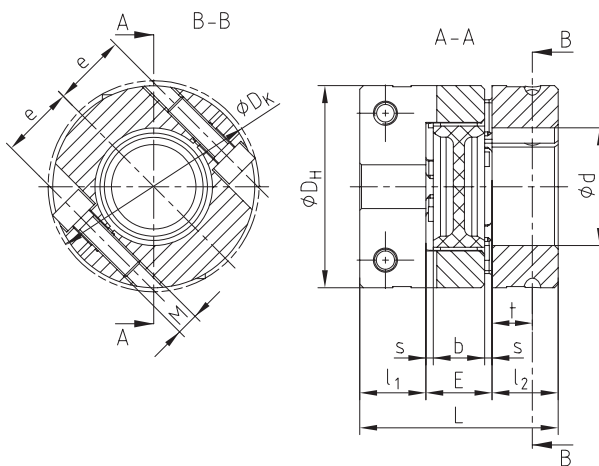

Hub types

Type 2.8

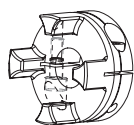

Short clamping hub C with axial slots without feather keyway
Type 2.8 from size 24 standard, size 7-19 type 2.8 single slotted

Type 2.9

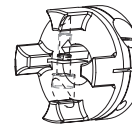

Short clamping hub C with axial slots with feather keyway
Type 2.9 from size 24 standard, size 7-19 type 2.9 single slotted

ROTEX® GS Clamping ring hubs light Backlash-free jaw couplings

Integrated clamping system made of aluminium

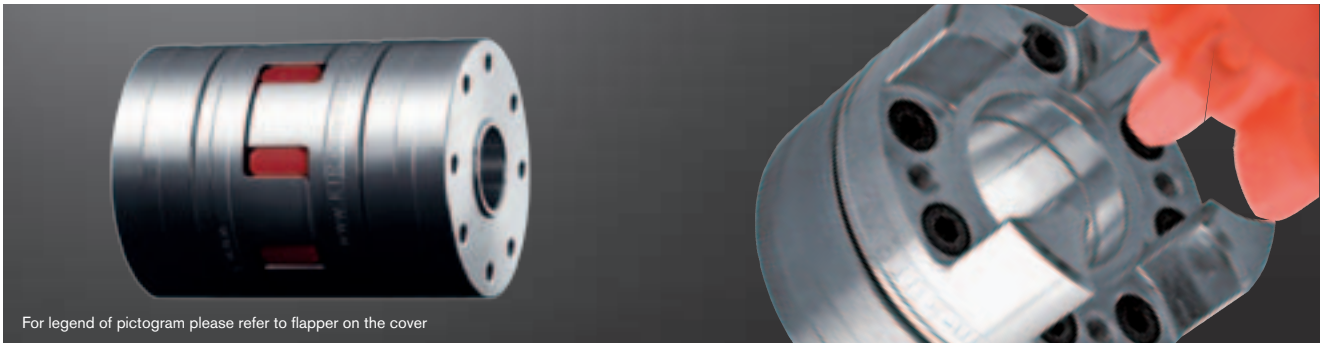

For legend of pictogram please refer to flapper on the cover



Tack thread M1 between clamping screws

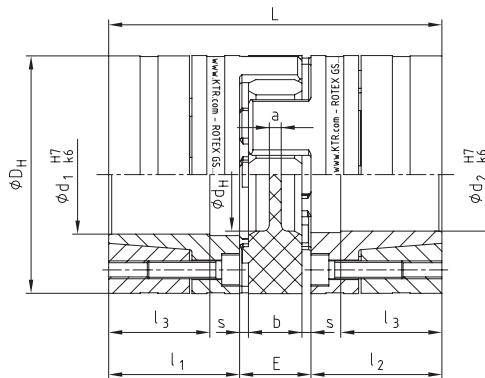

ROTEX® GS clamping ring hubs light

Size	Spider torque T _{KN} [Nm] ¹⁾					Dimensions [mm]								Clamping screws DIN EN ISO 4762				Weight per hub with max. bore [kg]	Mass moment of inertia per hub with max. bore [kg m ²]
	92 Sh-A	98Sh-A	64 Sh-D	maxi.d	D _H ²⁾	d _H	L	l ₁ ; l ₂	l ₃	E	b	s	a	M	Number z	T _A [Nm]	M ₁		
14	7,5	12,5	16,0	14	30	10,5	50	18,5	13,5	13	10	1,5	2,0	M3	4	1,34	M3	0,032	0,04 x 10 ⁻⁴
19	12	21	26	20	40	18	66	25	18	16	12	2,0	3,0	M4	6	3	M4	0,077	0,19 x 10 ⁻⁴
24	35	60	75	32	55	27	78	30	22	18	14	2,0	3,0	M5	4	6	M5	0,162	0,78 x 10 ⁻⁴
28	95	160	200	38	65	30	90	35	27	20	15	2,5	4,0	M5	8	6	M5	0,240	1,70 x 10 ⁻⁴
38	190	325	405	48	80	38	114	45	35	24	18	3,0	4,0	M6	8	10	M6	0,490	5,17 x 10 ⁻⁴
42	265	450	560	51	95	46	126	50	35	26	20	3,0	4,0	M8	4	25	M8	0,772	11,17 x 10 ⁻⁴
48	310	525	655	55	105	51	140	56	41	28	21	3,5	4,0	M10	4	49	M10	1,066	18,81 x 10 ⁻⁴

¹⁾ Other spiders/selection see page 18 et seqq.

²⁾ ØD_H + 2 mm with high speeds for expansion of spider

Review of shaft-hub-connection: Friction torques for hub type 6.0 light

Size		Ø6	Ø10	Ø11	Ø14	Ø15	Ø16	Ø19	Ø20	Ø24	Ø25	Ø28	Ø30	Ø32	Ø35	Ø38	Ø40	Ø42	Ø45	Ø48	Ø50	Ø55*	
14	H7/k6	6,9	17	22	31																		
	H7/h6	4,7	14	19	22																		
19	H7/k6		28	35	51	61	43	68	78														
	H7/h6		23	30	44	55	32	58	70														
24	H7/k6				72	85	79	119	134	145	160	211											
	H7/h6				64	79	67	106	124	108	123	172											
28	H7/k6						120	177	161	247	271	305	355	294	366	382							
	H7/h6						102	160	132	224	250	281	336	222	294	311							
38	H7/k6								248	376	411	486	563	553	673	665	748	832	732	848			
	H7/h6								210	344	382	453	536	454	577	550	632	718	614	732			
42	H7/k6											559	645	666	806	859	957	924	1069	1221	1229		
	H7/h6											522	616	558	703	800	909	806	960	1125	1173		
48	H7/k6												706	795	962	1047	1165	1160	1339	1527	1393	1652	
	H7/h6												650	735	914	983	1110	1025	1216	1422	1207	—	

* From Ø55 tolerance G7/m6

With bigger clearance the torque is reduced. As shaft material steel or nodular iron with a yield point of approx. 250 N/mm² or more can be used. For the stiffness calculation of the shaft/hollow shaft see KTR standard 45510 at our homepage www.ktr.com.

Ordering example:	ROTEX® GS 24	98 Sh-A-GS	d20	6.0 light – Ø 24		6.0 light – Ø 20	
		Coupling size	Spider hardness	Optional: Bore in spider	Hub type	Finish bore	Hub type

ROTEX® GS Clamping ring hubs made of steel

Backlash-free jaw couplings

Integrated clamping system made of steel

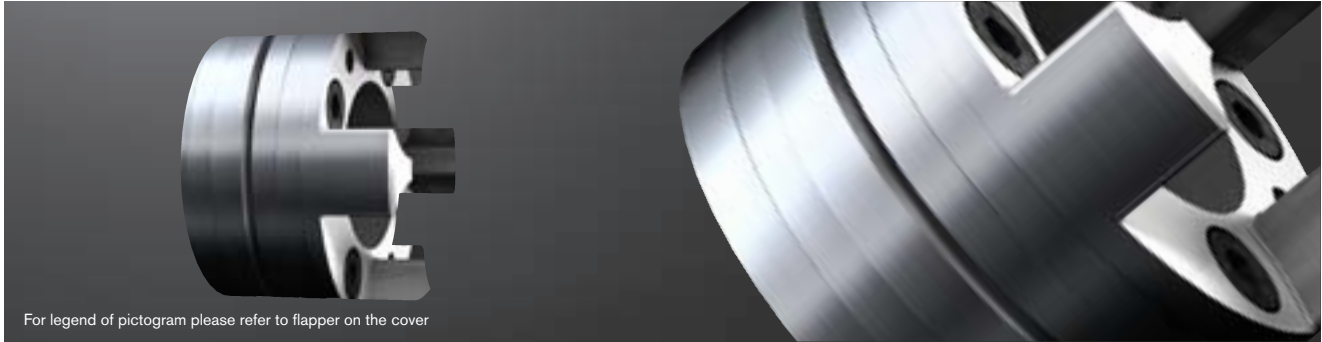

For legend of pictogram please refer to flapper on the cover

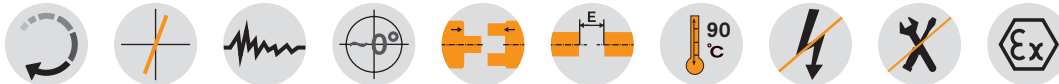

Tack thread M1 between clamping screws

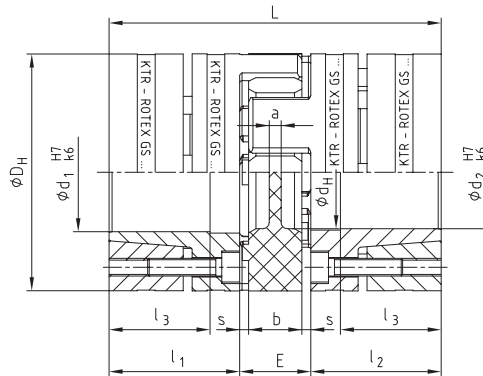

ROTEX® GS clamping ring hubs made of steel

Size	Spider torque T_{KN} [Nm] ¹⁾			Dimensions [mm]										Clamping screws DIN EN ISO 4762			Weight per hub with max. bore [kg]	Mass moment per hub with max. bore [kg m ²]
	98 Sh-A	64 Sh-D	72 Sh-D	maxi.d	D_H ²⁾	d_H	L	l_1 ; l_2	l_3	E	b	s	a	M	Num- ber z	T_A [Nm]		
19	21	26	—	20	40	18	66	25 18	16	12	2,0	3,0	M4	6	4,1	M4	0,179	$0,44 \times 10^{-4}$
24	60	75	97	28	55	27	78	30 22	18	14	2,0	3,0	M5	4	8,5	M5	0,399	$1,91 \times 10^{-4}$
28	160	200	260	38	65	30	90	35 27	20	15	2,5	4,0	M5	8	8,5	M5	0,592	$4,18 \times 10^{-4}$
38	325	405	525	48	80	38	114	45 35	24	18	3,0	4,0	M6	8	14	M6	1,225	$12,9 \times 10^{-4}$
42	450	560	728	51	95	46	126	50 35	26	20	3,0	4,0	M8	4	35	M8	2,30	$31,7 \times 10^{-4}$
48	525	655	852	55	105	51	140	56 41	28	21	3,5	4,0	M10	4	69	M10	3,08	$52,0 \times 10^{-4}$
55	685	825	1072	70	120	60	160	65 45	30	22	4,0	4,5	M10	4	69	M10	4,67	$103,0 \times 10^{-4}$
65	940	1175	1527	70	135	68	185	75 55	35	26	4,5	4,5	M12	4	120	M12	6,70	$191,0 \times 10^{-4}$
75	1920	2400	—	80	160	80	210	85 63	40	30	5,0	5,0	M12	5	120	M12	9,90	$396,8 \times 10^{-4}$
90	3600	4500	—	105	200	104	245	100 75	45	34	5,5	6,5	M16	5	295	M16	17,7	1136×10^{-4}

¹⁾ Other spiders/selection see page 18 et seqq.

²⁾ $\phi D_H + 2$ mm with high speeds for expansion of spider

Review of shaft-hub-connection: Friction torques for hub type 6.0 steel

Size		$\phi 10$	$\phi 11$	$\phi 14$	$\phi 15$	$\phi 16$	$\phi 19$	$\phi 20$	$\phi 24$	$\phi 25$	$\phi 28$	$\phi 30$	$\phi 32$	$\phi 35$	$\phi 38$	$\phi 40$	$\phi 42$	$\phi 45$	$\phi 48$	$\phi 50$	$\phi 55^*$	$\phi 60^*$	$\phi 65^*$	$\phi 70^*$	$\phi 80^*$	$\phi 90^*$	$\phi 95^*$	$\phi 100^*$	$\phi 105^*$
19	H7/k6	27	32	69	84	57	94	110																					
	H7/h6	15	18	57	74	38	76	94																					
24	H7/k6			70	87	56	97	114	116	133	192																		
	H7/h6			55	74	32	72	93	84	103	173																		
28	H7/k6				108	131	207	148	253	285	315	382	330	433	503														
	H7/h6				74	97	172	94	207	242	267	343	260	377	453														
38	H7/k6						208	353	395	439	531	463	603	593	689	793	776												
	H7/h6						136	290	337	373	476	367	525	491	601	721	677												
42	H7/k6							358	398	483	416	547	536	625	571	704	851	865											
	H7/h6							299	331	428	320	470	434	537	452	605	778	781											
48	H7/k6								616	704	899	896	1030	962	1160	1379	1222	1543											
	H7/h6							513	590	806	775	924	822	1042	1290	1073	—	—	—	—	—	—	—	—	—	—	—	—	—
55	H7/k6											863	856	991	918	1119	1110	1247	1277	1665	1605	2008							
	H7/h6											750	710	863	750	976	934	1089	—	—	—	—	—	—	—	—	—	—	
65	H7/k6													1446	1355	1637	1635	1827	1887	2429	2368	2930							
	H7/h6													1275	1135	1447	1404	1619	—	—	—	—	—	—	—	—	—	—	—
75	H7/k6														1710	2053	2059	2294	2384	3040	2983	3664	4293						
	H7/h6														1460	1836	1797	2056	—	—	—	—	—	—	—	—	—	—	—
90	H7/k6																	3845	4249	4794	5858	5900	7036	8047	9247	9575	10845		
	H7/h6																	3445	—	—	—	—	—	—	—	—	—	—	—

* From $\phi 55$ tolerance G7/m6

With bigger clearance the torque is reduced. For the stiffness calculation of the shaft/hollow shaft see KTR standard 45510 at our homepage at www.ktr.com.

Ordering example:	ROTEX® GS 24	98 Sh-A-GS	d20	6.0 steel	$\phi 24$	6.0 steel	$\phi 20$
		Coupling size	Spider hardness	Optional: Bore in spider	Hub type	Finish bore	Hub type

ROTEX® GS P

Backlash-free jaw couplings

Highly accurate type P according to DIN 69002



For legend of pictogram please refer to flapper on the cover

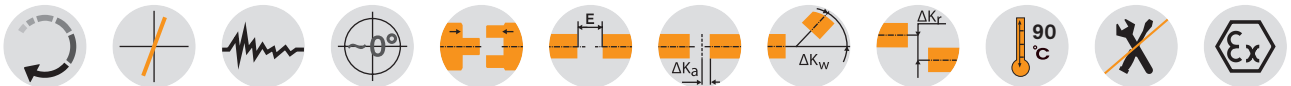

ROTEX® GS type P material of hub/clamping ring steel

Size	Spider torque T_{KN} [Nm] ¹⁾		Dimensions [mm]											Tightening torque of clamping screws TA [Nm]	Weight per hub with bore $\varnothing d$ standard [kg]	Mass moment of inertia with bore $\varnothing d$ standard [kgm ²]
	98 Sh-A	64 Sh-D	maximum d	D_H ²⁾	d_H	L	$l_1:l_2$	l	E	b	s	a	d_3			
14 P	12,5	16	15	32	10,5	50	18,5	15,5	13	10	1,5	2	—	1,89	0,08	$0,011 \times 10^{-3}$
19 P	21	26	20	40	18	66	25	21	16	12	2	3	—	3,05	0,19	$0,046 \times 10^{-3}$
24 P	60	75	28	55	27	78	30	25	18	14	2	3	—	8,5	0,44	$0,201 \times 10^{-3}$
28 P	160	200	38	65	30	90	35	30	20	15	2,5	4	—	8,5	0,64	$0,438 \times 10^{-3}$
38 P	325	405	48	80	38	114	45	40	24	18	3	4	—	14	1,32	$1,325 \times 10^{-3}$
42 P	450	560	51	95	46	126	50	45	26	20	3	4	18,5	35	2,23	$3,003 \times 10^{-3}$
48 P	525	655	55	105	51	140	56	50	28	21	3,5	4	20,5	69	3,09	$5,043 \times 10^{-3}$
55 P	685	825	70	120	60	160	65	58	30	22	4	4,5	22,5	69	4,74	$10,02 \times 10^{-3}$
65 P	940	1175	70	135	68	185	75	55	35	26	4,5	4,5	30	120	6,70	$191,0 \times 10^{-4}$
75 P	1920	2400	80	160	80	210	85	63	40	30	5,0	5,0	40	120	9,90	$396,8 \times 10^{-4}$
90 P	3600	4500	105	200	104	245	100	75	45	34	5,5	6,5	50	120	17,7	1136×10^{-4}

¹⁾ Other spiders/selection see page 18 et seqq.

²⁾ $\varnothing D_H + 2$ mm with high speeds for expansion of spider

For the stiffness calculation of the shaft/hollow shaft see KTR standard 45510 on our homepage www.ktr.com

Review of shaft-hub-connection: Friction torques for hub type 6.0P steel

Size		$\varnothing 10$	$\varnothing 11$	$\varnothing 14$	$\varnothing 15$	$\varnothing 16$	$\varnothing 19$	$\varnothing 20$	$\varnothing 24$	$\varnothing 25$	$\varnothing 28$	$\varnothing 30$	$\varnothing 32$	$\varnothing 35$	$\varnothing 38$	$\varnothing 40$	$\varnothing 42$	$\varnothing 45$	$\varnothing 48$	$\varnothing 50$	$\varnothing 55$	$\varnothing 60$	$\varnothing 65$	$\varnothing 70$	$\varnothing 80$	$\varnothing 90$	$\varnothing 95$	$\varnothing 100$	$\varnothing 105$	
14	H6/k6	11	13	29																										
19	H6/k6	34	41	75	90	68	104	119																						
24	H6/k6			79	95	70	110	126	134	149	201																			
28	H6/k6				128	150	225	177	278	307	341	403	366	461	528															
38	H6/k6							247	386	426	475	560	511	641	644	733	828	825												
42	H6/k6								389	433		512	464	585	586	669	631	753	888	906										
48	H6/k6											672	762	945	957	1082	1033	1219	1423	1296	1606									
55	H6/k6													920	929	1055	1002	1190	1198	1325	1388	1743	1722	2088						
65	H6/k6															1532	1465	1731	1750	1931	2034	2534	2521	3038						
75	H6/k6																1835	2161	2190	2413	2551	3161	3158	3789	4421					
90	H6/k6																				4046	4503	5057	6079	6181	7324	8398	9530	9892	11084

*From $\varnothing 55$ G6/m6.

With bigger clearance the torque is reduced. For the stiffness calculation of the shaft/hollow shaft see KTR standard 45510 at our homepage at www.ktr.com.

Selection for stub spindles according to DIN 69002

Spindle drive	ROTEX® GS P size	Dimensions to DIN 69002											Transmittable torque T_R with $\varnothing d$ [Nm] ³⁾	Weight per hub with bore $\varnothing d$ standard [kg] ³⁾	Mass moment of inertia with bore $\varnothing d$ standard [kgm ²] ³⁾	
		Standard spindle shaft diameter d	d_1	d_2	d_3	D_H	$l_1:l_2$	L	E							
25 x 20	14 P	14	17	17	8,5	32	18,5	50	13					25	0,08	$0,011 \times 10^{-3}$
32k x 25	19 P37.5	16	20	19	9,5	37,5	25	66	16					60	0,16	$0,037 \times 10^{-3}$
32g x 30	19 P	19	23	22	9,5	40	25	66	16					71	0,19	$0,046 \times 10^{-3}$
40 x 35	24 P50	24	28	29	12,5	50	30	78	18					108	0,331	$0,136 \times 10^{-3}$
50 x 45	24 P	25	30	30	12,5	55	30	78	18					170	0,44	$0,201 \times 10^{-3}$
63 x 55	28 P	35	40	40	14,5	65	35	90	20					506	0,64	$0,438 \times 10^{-3}$
80 x 75	38 P	40	46	46	16,5	80	45	114	24					821	1,32	$1,325 \times 10^{-3}$

³⁾ Standard spindle shaft diameters

Ordering example:	ROTEX® GS 24	P	98 Sh-A-GS	6.0 - $\varnothing 25$		6.0 - $\varnothing 25$	
	Coupling size	Type	Spider hardness	Hub type	Finish bore	Hub type	Finish bore

Components

Tack thread M1 between clamping screws

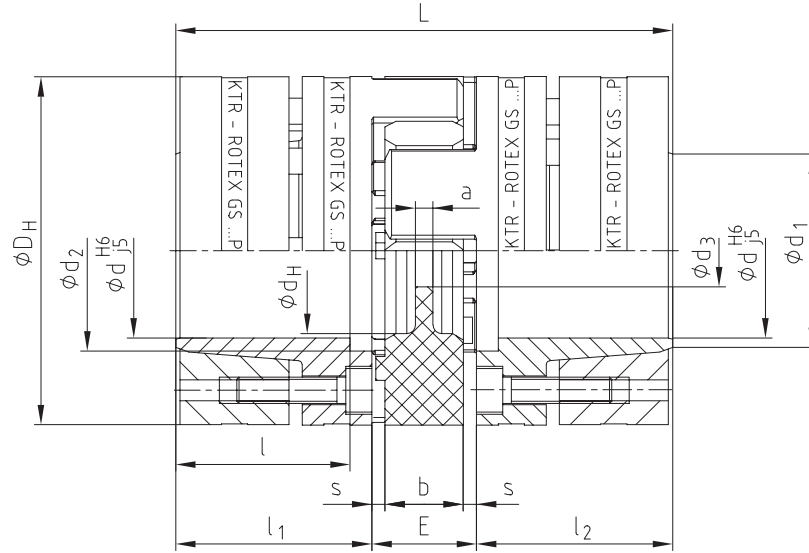

ROTEX® GS type P with central coolant supply for stub spindles and multiple spindle heads

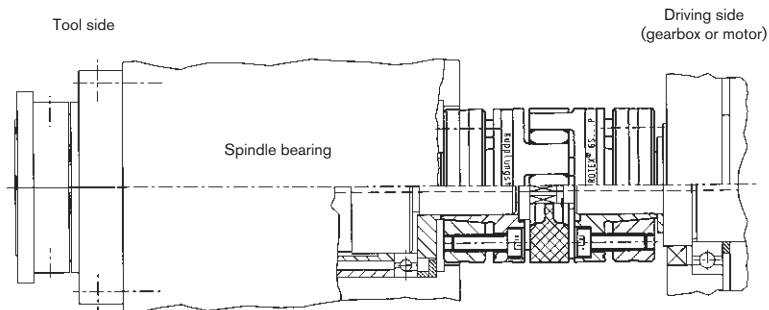

ROTEX® GS expansion hubs

Backlash-free jaw couplings

Clamping system for hollow shaft connection

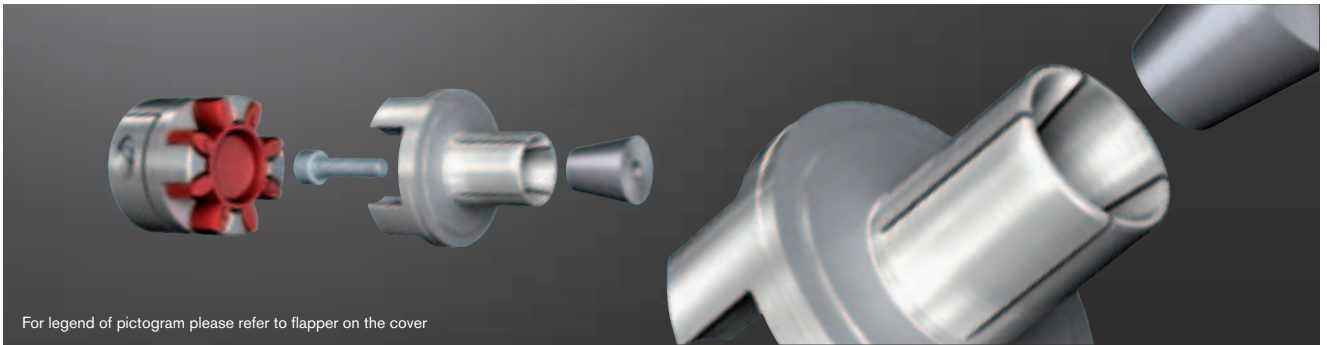

For legend of pictogram please refer to flapper on the cover

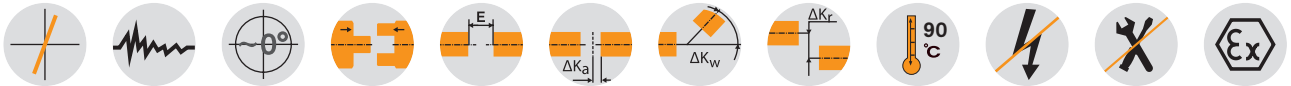

ROTEX® GS expansion hub		Material of expansion hub aluminium/material of clamp pin stainless steel													
Size	Spider torque TKN [Nm] 2)					Dimensions [mm]									
	80 Sh-A	92 Sh-A	98 Sh-A	64 Sh-D	72 Sh-D	D ₁ 3)	D ₂	D _H	l ₁ 3)	l ₄ 3)	l ₅ 3)	l ₆	E	b	s
9	1,8	3,0	5,0	6,0	–	10	–	20	20	11	–	0	10	8	1,0
12	3,0	5,0	9,0	12,0	–	10	20	25	19	14	1,5	2	12	10	1,0
14	4,0	7,5	12,5	16,0	–	12	24	30	18,5	12,5	3	2	13	10	1,5
19	6,0	12,0	21,0	26,0	–	20	35	40	28	20	1	0	16	12	2,0
24	–	35	60	75	97	25	45	55	38	30	1	4	18	14	2,0
28	–	95	160	200	260	35	55	65	44	36	1	5	20	15	2,5

¹⁾ Expansion hub can be combined with other hub designs as a counter side, too. l₂ depending on hub design. Other hub types see page 124

²⁾ For selection see page 18 et seqq.

³⁾ The dimensions D₁; l₁, l₄ and l₅ are examples. Other dimensions on customers' request.

Review of shaft-hub-connection: Friction torques for hub type 9.0*						
Size	D ₁	D ₂	l ₁	l ₄ 3)	l ₅	Friction torque [Nm]
9	10	–	20	11	–	6,4
12	10	20	19	14	1,5	7,7
14	12	24	18,5	12,5	3	7,7
19	20	35	28	20	1	35,7
24	25	45	38	30	1	82
28	35	55	44	36	1	182

* The transmittable torques of the clamping connection consider the dimensions D₁, D₂, l₄ and l₅ as specified with steel being the material of the hollow shaft.

Ordering example:	ROTEX® GS 24	98 Sh-A-GS	d20	9.0 – Ø 24		2.5 – Ø 20	
	Coupling size	Spider hardness	Optional: Bore in spider	Hub type	D ₁	Hub type	Finish bore

ROTEX® GS expansion hub type 9.0 with clamping hub ¹⁾

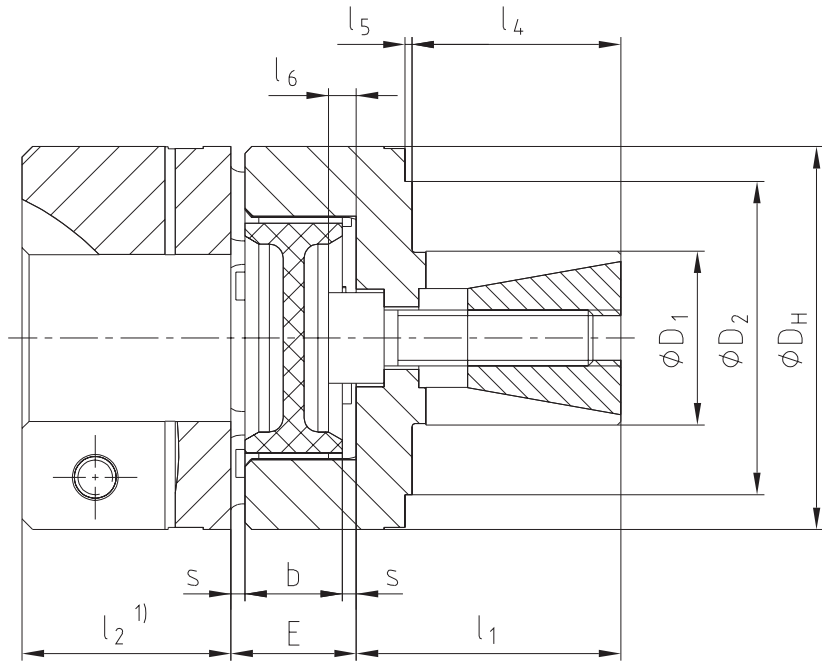

ROTEX® GS expansion hub for axis of belt

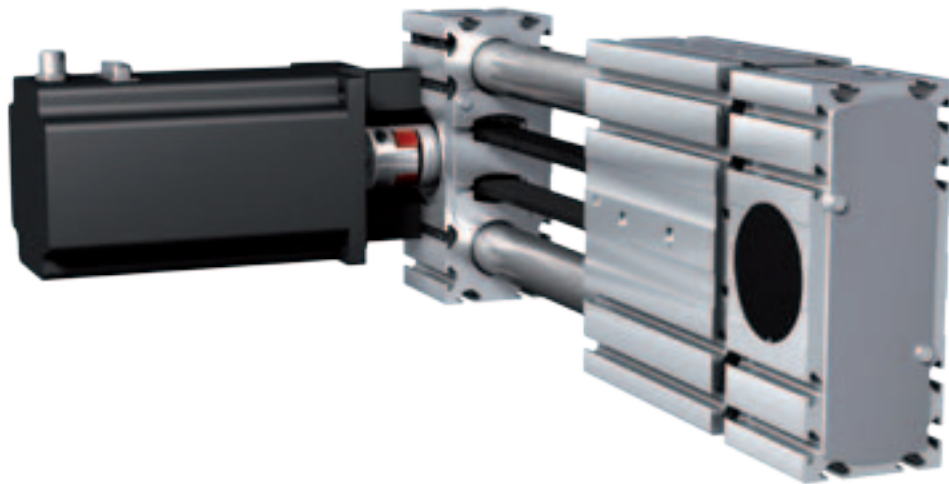

Special types for hollow shaft connections

Shaft extension

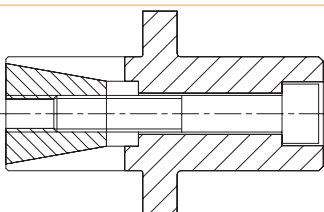

ROTEX® GS hub with CLAMPEX® KTR 150

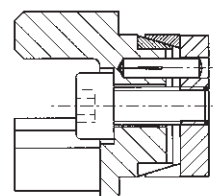

ROTEX® GS A-H

Backlash-free jaw couplings

Drop-out center design coupling

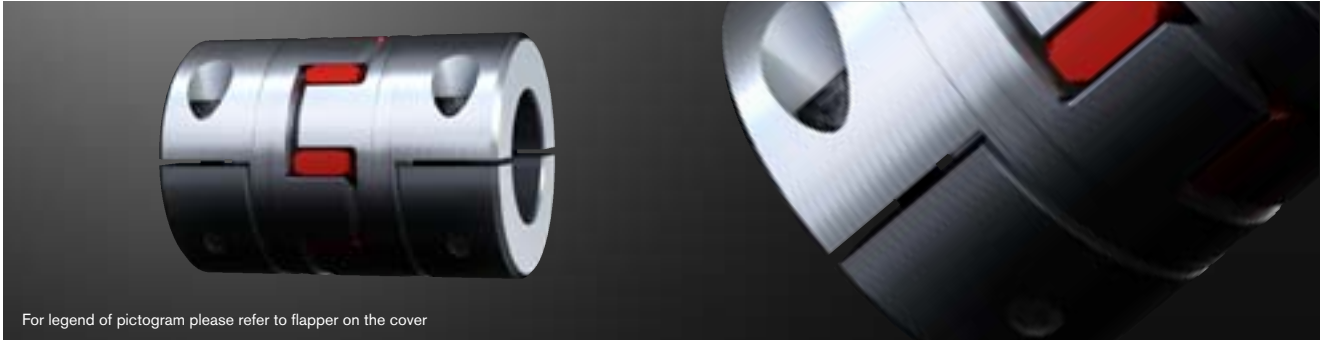

For legend of pictogram please refer to flapper on the cover

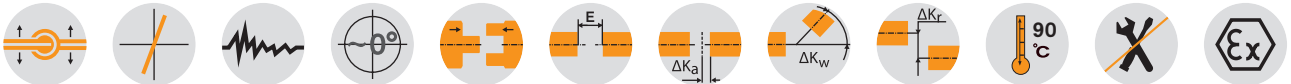

ROTEX® GS Type A-H hub material aluminium												
Size	Max. finish bore Ød [mm]	Dimensions [mm]									Cyl. screws DIN EN ISO 4762	
		L	l ₁ ; l ₂	E	b	s	D _H	D _K	x ₁ /x ₂	E ₁	Mxl	T _A [Nm]
19	20	66	25	16	12	2,0	40	46	17,5	31	M6x16	10
24	28	78	30	18	14	2,0	55	57,5	22,0	34	M6x20	10
28	38	90	35	20	15	2,5	65	73	25,0	40	M8x25	25
38	45	114	45	24	18	3,0	80	83,5	33,0	48	M8x30	25
42	50	126	50	26	20	3,0	95	93,5	39	48	M10x30	49

Technical data								
Size	Spider Shore-GS 1)	Shore range	Max. speed [rpm]	Torque [Nm]		Static torsion spring stiffness ²⁾ [Nm/rad]	Weight per hub with max. bore [kg]	Mass moment of inertia J of each hub with max. bore diameter [kgm ²]
				T _{KN}	T _{Kmax}			
19	80	A	9550	6,0	12,0	618	77 x 10 ⁻³	19,6 x 10 ⁻⁶
	92	A		12,0	24,0	1090		
	98	A		21,0	42,0	1512		
	64	D		26,0	52,0	2560		
24	92	A	6950	35	70	2280	161 x 10 ⁻³	77,3 x 10 ⁻⁶
	98	A		60	120	3640		
	64	D		75	150	5030		
28	92	A	5850	95	190	4080	240 x 10 ⁻³	173 x 10 ⁻⁶
	98	A		160	320	6410		
	64	D		200	400	10260		
38	92	A	4750	190	380	6525	470 x 10 ⁻³	496 x 10 ⁻⁶
	98	A		325	650	11800		
	64	D		405	810	26300		
42	92	A	4000	265	530	10870	1770 x 10 ⁻³	2409 x 10 ⁻⁶
	98	A		450	900	21594		
	64	D		560	1120	36860		

¹⁾ Other spiders/selection see page 18 et seqq.

²⁾ Static torsion spring stiffness with 0.5 x T_{KN}

To make sure that the coupling can be assembled/disassembled radially, please observe the insertion dimension x₁/x₂ of the shafts.

Review of shaft-hub-connection: Friction torques for hub type 7.8																							
Size	Ø8	Ø10	Ø11	Ø14	Ø15	Ø16	Ø18	Ø19	Ø20	Ø22	Ø24	Ø25	Ø28	Ø30	Ø32	Ø35	Ø38	Ø40	Ø42	Ø45	Ø46	Ø48	Ø50
19	17	21	23	30	32	34	38	40	42														
24		21	23	30	32	34	38	40	42	47	51	53	59										
28				54	58	62	70	74	78	86	93	97	109	117	124	136	148						
38							70	74	78	86	93	97	109	117	124	136	148	156	163	175			
42										136	149	155	174	186	198	217	235	248	260	279	285	297	310

Ordering example:	ROTEX® GS 38	A-H	98 Sh-A-GS	7.8 – Ø 38		7.9 – Ø 30	
	Coupling size	Type	Spider hardness	Hub type	Finish bore	Hub type	Finish bore

Type A-H

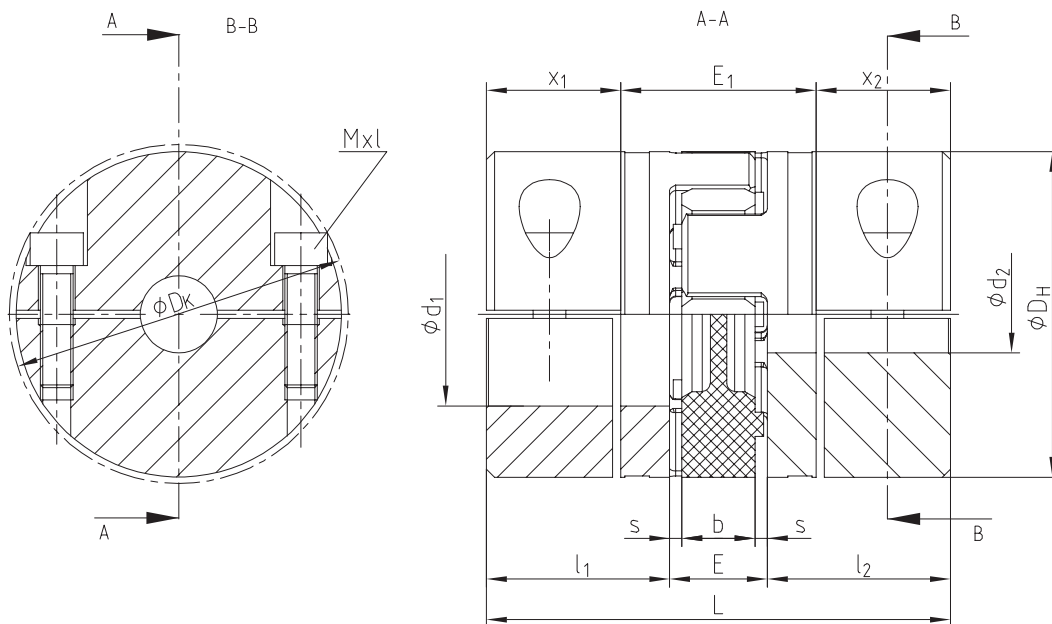

Please note:
The feather keys are offset to each other by approx. 5°!
Hub material: Al-H

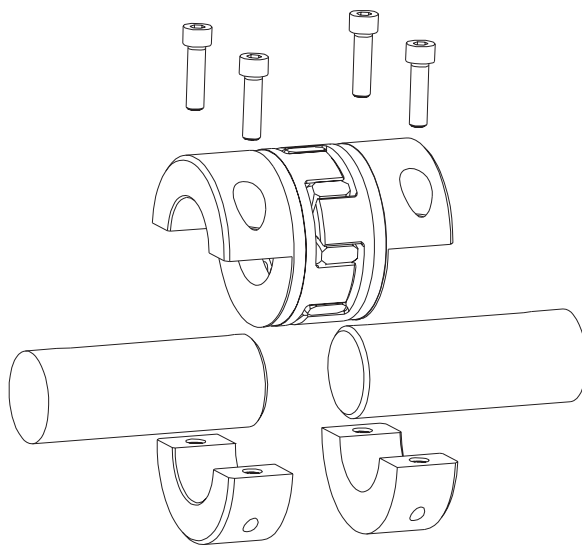

Hub types

Type 7.8

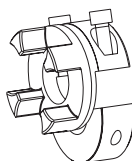

Clamping hub type H without feather keyway for single-cardanic connection

Type 7.9

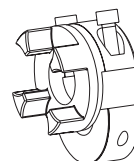

Clamping hub type H with feather keyway for single-cardanic connection

ROTEX® GS DKM

Backlash-free jaw couplings

Double-cardanic jaw coupling

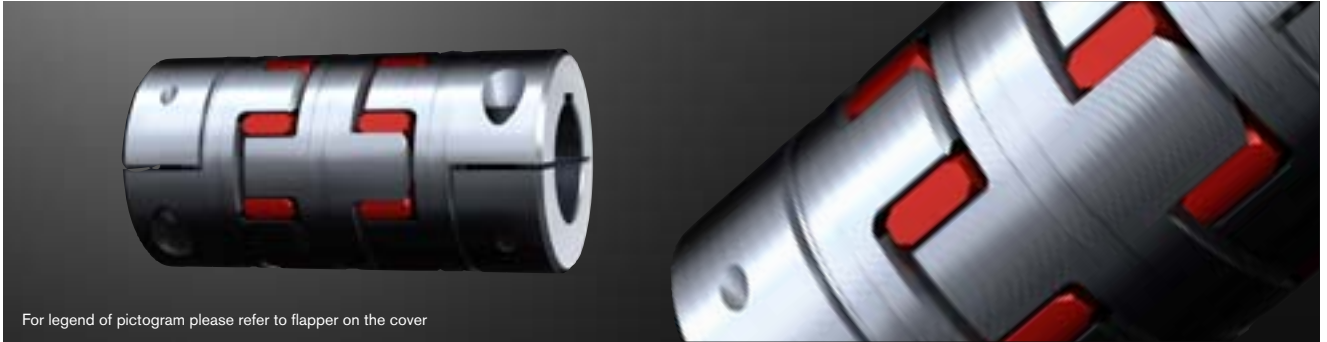

For legend of pictogram please refer to flapper on the cover

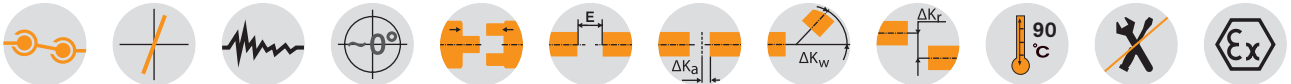

ROTEX® GS DKM Spider material aluminium/hub material depends on hub design

Size	Spider torque T _{KN} [Nm] ¹⁾		Dimensions [mm]													
	98 Sh-A	64 Sh-D	max. d ²⁾	D	D _H	d _H	d _{H1}	l ₁ ; l ₂	M; N	l ₁₁	l ₁₂	L _{DKM}	E	b	s	a
5	0,9	—	5	—	10	—	—	5	—	3	13	23	5	4	0,5	4,0
7	2,0	2,4	7	—	14	—	—	7	—	4	20	34	8	6	1,0	6,0
9	5,0	6,0	11	—	20	7,2	—	10	—	5	25	45	10	8	1,0	1,5
12	9,0	12,0	12	—	25	8,5	—	11	—	6	30	52	12	10	1,0	3,5
14	12,5	16,0	16	—	30	10,5	—	11	—	8	34	56	13	10	1,5	2,0
19	21,0	26,0	24	—	40	18,0	18	25	—	10	42	92	16	12	2,0	3,0
24	60	75	28	—	55	27,0	27	30	—	16	52	112	18	14	2,0	3,0
28	160	200	38	—	65	30,0	30	35	—	18	58	128	20	15	2,5	4,0
38	325	405	45	—	80	38,0	38	45	—	20	68	158	24	18	3,0	4,0
42	450	560	55	85	95	46	46	50	28	22	74	174	26	20	3,0	4,0
48	525	655	62	95	105	51	51	56	32	24	80	192	28	21	3,5	4,0
55	685	825	74	110	120	60	60	65	37	28	88	218	30	22	4,0	4,5

¹⁾ Other spiders/selection see page 18 et seqq.

²⁾ Depending on hub type. Hub types can be freely selected, for summary see page 124

Ordering example:

ROTEX® GS 24	DKM	98 Sh-A-GS	d25	1.0 - Ø38		2.5 - Ø25	
Coupling size	Type	Spider hardness	Optional: Bore in spider	Hub type	Finish bore	Hub type	Finish bore

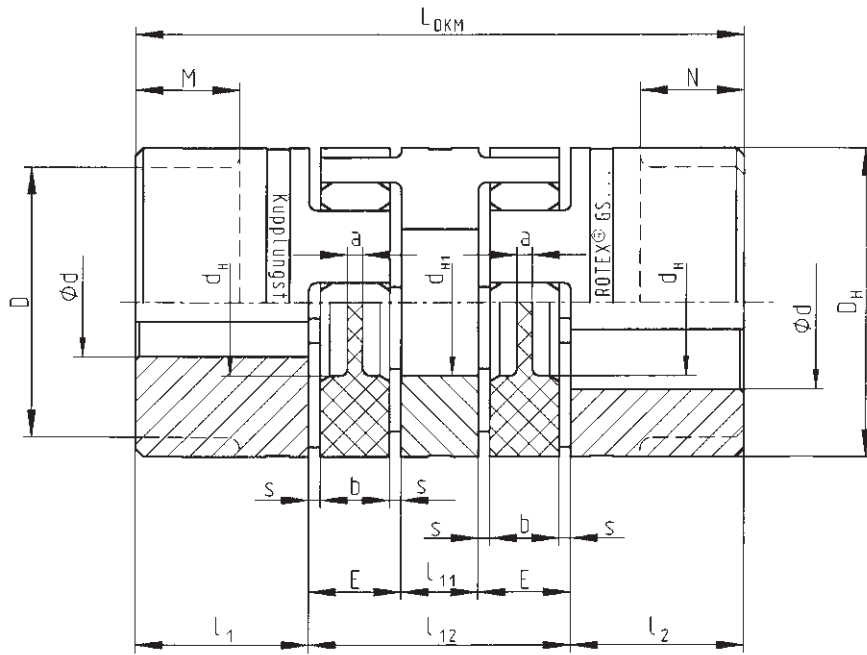

Other types:

ROTEX® GS - CF - DKM

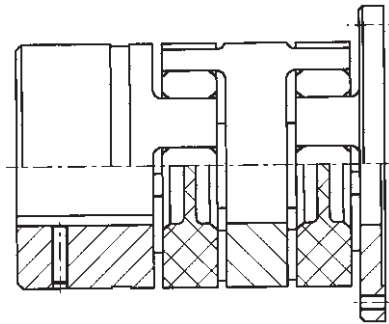

ROTEX® GS DKM with clamping hubs DH type 7.5/7.6

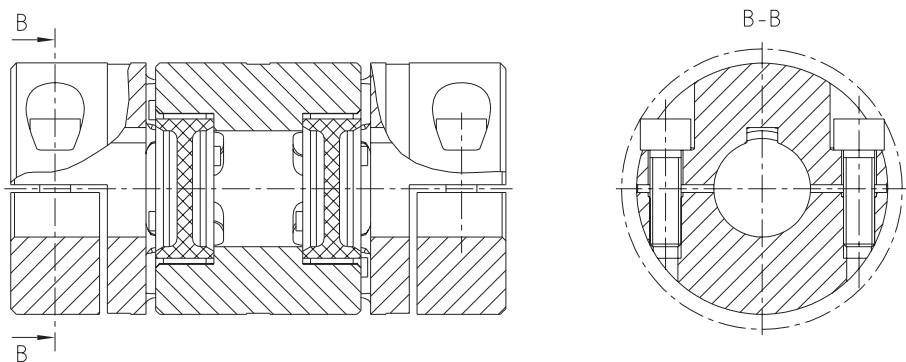

ROTEX® GS ZR3

Backlash-free intermediate shaft couplings

Intermediate shaft coupling with aluminium pipe bonded



For legend of pictogram please refer to flapper on the cover



ROTEX® GS type ZR3 hub material aluminium/intermediate pipe material aluminium

Size	Dimensions [mm]															Cyl. screw DIN EN ISO 4762	
	Minimum and maximum finish bore		General													8.8	T _A [Nm]
	d _{min.}	d _{max.}	D _H	l ₁	L	l ₃	E	LR		LZR = LR + 2 • l ₃		d _R	D _K	t ₁	e		
14	5	16	30	18,5	36,0	14,5	13	72	2971	101	3000	28	32,5	7,5	11,5	M3	1,34
19	8	20	40	25	49,0	17,5	16	98	2965	133	3000	40	46	8,0	14,5	M6	10
24	10	28	55	30	59,0	22,0	18	121	3456	165	3500	50	57,5	10,5	20	M6	10
28	14	38	65	35	67,0	25,0	20	137	3950	187	4000	60	73	11,5	25	M8	25
38	18	45	80	45	83,5	33,0	24	169	3934	235	4000	70	83,5	15,5	30	M8	25
42	22	50	95	50	93,0	36,5	26	180	3927	253	4000	80	93,5	18,0	32	M10	49
48	22	55	105	56	100,0	39,5	28	202	3921	281	4000	100	105	18,5	36	M12	86

Technical data of type ZR3

Size	Spider torque T _{KN} [Nm] ¹⁾		Moment of inertia [10 ⁻³ kgm ²]			Stat. torsion spring stiffness [Nm2/rad] ³⁾
	98 Sh-A	64 Sh-D	Hub ²⁾	ZR hub	Pipe/meter	
14	12,5	16,0	0,00406	0,00238	0,088	858
19	21,0	26,0	0,02002	0,01304	0,329	3243,6
24	60,0	75,0	0,07625	0,04481	0,673	6631,8
28	160	200	0,17629	0,10950	1,199	11814,1
38	325	405	0,50385	0,2572	2,972	29290,4
42	450	560	1,12166	0,5523	4,560	44929,7
48	525	655	1,87044	1,1834	9,251	91158,2

¹⁾ Other spiders/selection see page 18 et seqq.

²⁾ With d_{max.}

³⁾ Torsion spring stiffness with a length of 1 m of intermediate pipe with L_{Rohr} = LZR - 2 · L

For enquiries and orders please specify the shaft distance dimension LR along with the maximum speed to review the critical bending speed.

The intermediate pipe could be combined with other hub designs, but in that case it can no longer be radially disassembled. Please mention the shaft distance dimension required in your order.

With vertical application a support washer has to be used (please mention in your order).

Insertion dimension of shaft l₃, to make sure that the coupling can be assembled/disassembled radially.

Review of shaft-hub-connection: Friction torques for hub type 7.5

Size	Ø5	Ø6	Ø8	Ø10	Ø11	Ø14	Ø15	Ø16	Ø18	Ø19	Ø20	Ø22	Ø24	Ø25	Ø28	Ø30	Ø32	Ø35	Ø38	Ø40	Ø42	Ø45	Ø46	Ø48	Ø50	Ø55
14	2,6	3,1	4,2	5,2	5,7	7,3	7,8	8,3																		
19			17	21	23	30	32	34	38	40	42															
24				21	23	30	32	34	38	40	42	47	51	53	59											
28						54	58	62	70	74	78	86	93	97	109	117	124	136	148							
38									70	74	78	86	93	97	109	117	124	136	148	156	163	175				
42												136	149	155	174	186	198	217	235	248	260	279	285	297	310	
48												199	217	226	253	271	290	317	344	362	380	407	416	434	452	498

Ordering example:

ROTEX® GS 24	ZR3	1200 mm	98 Sh A-GS	7.5 - Ø24	7.5 - Ø24
Coupling size	Type	Shaft distance dimension (LR)	Spider hardness	Hub type	Finish bore
				Hub type	Finish bore

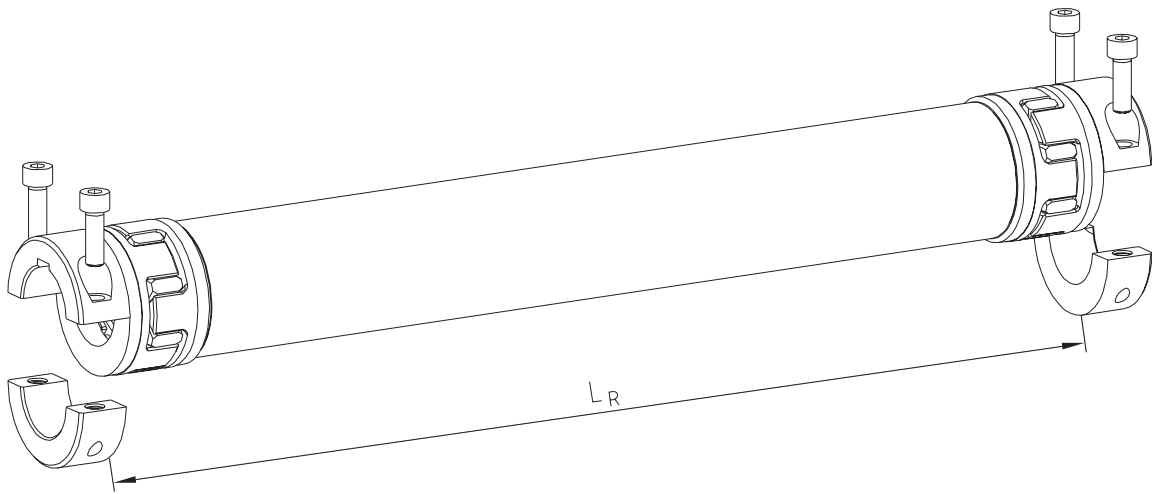
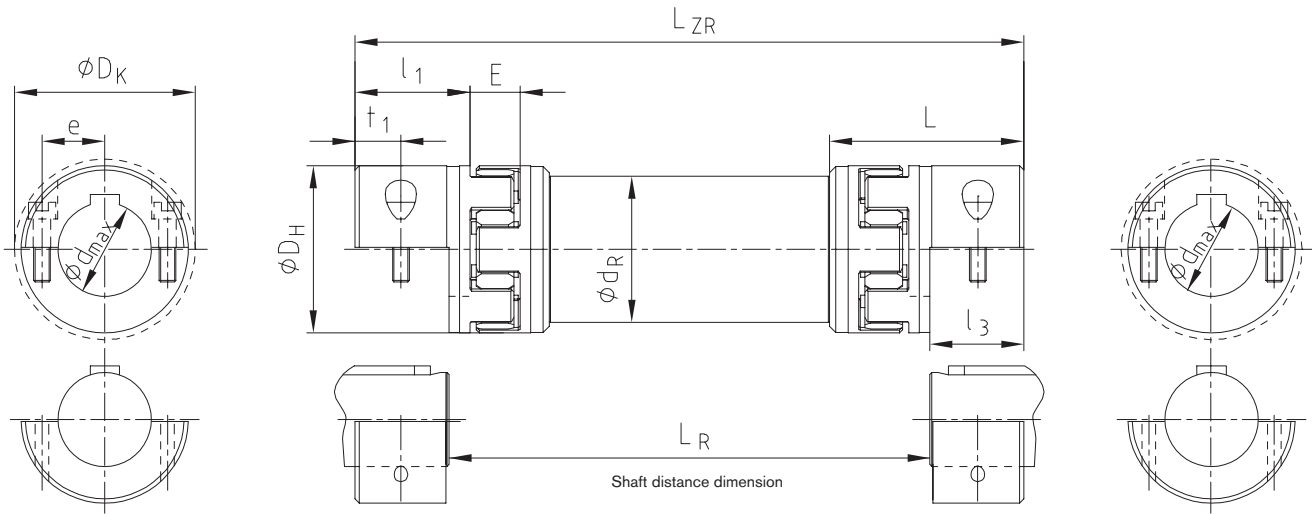

Hub types

Type 7.5

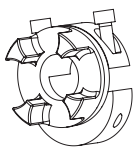

Clamping hub type DH without feather keyway for double-cardanic connections

Type 7.6

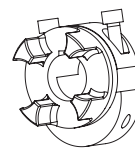

Clamping hub type DH with feather keyway for double-cardanic connections

ROTEX® GS ZR1 und ZR2

Backlash-free intermediate shaft couplings

Intermediate shaft couplings with steel pipe/steel shaft



For legend of pictogram please refer to flapper on the cover



ROTEX® GS Type ZR1																	
Size	Spider torque T _{KN} [Nm] ¹⁾		Maximum finish bore d ²⁾	Dimensions [mm]										Cyl. screw DIN EN ISO 4762 – 8.8 Mxl	Tightening torque T _A [Nm]	Friction torque T _R [Nm]	
	98 Sh-A	64 Sh-D		D _H	l ₁ ; l ₂	L	E	b	s	B	LR1	Minimum dimension for LR1	LZR1				d _R ³⁾
14 ZR1	12,5	16,0	16	30	11	35	13	10	1,5	11,5	Please mention with inquiries and orders	71	LR1+22	14x2,5	M3x12	1,34	6,1
19 ZR1	21,0	26,0	24	40	25	66	16	12	2,0	14,0		110	LR1+50	20x3,0	M6x16	10,5	34
24 ZR1	60	75	28	55	30	78	18	14	2,0	16,0		128	LR1+60	25x2,5	M6x20	10,5	45
28 ZR1	160	200	38	65	35	90	20	15	2,5	17,5		145	LR1+70	35x4,0	M8x25	25	105
38 ZR1	325	405	45	80	45	114	24	18	3,0	21,0		180	LR1+90	40x4,0	M8x30	25	123

ROTEX® GS Type ZR2																			
Size	Spider torque T _{KN} [Nm] ¹⁾		Maximum finish bore d ²⁾	Dimensions [mm]										Precision tube [mm] [Nm ² /rad]		Clamping set size KTR 250 dxD	Clamping screws DIN EN ISO 4762–12.9 Mxl	Tightening torque T _A [Nm]	
	98 Sh-A	64 Sh-D		D _H	l ₁ ; l ₂	l ₃	L	E	b	s	B	LR2	Minimum dimension for LR2	LZR2	d _R				C ₂ ⁴⁾
14 ZR2	12,5	16,0	16	30	11	26	50	13	10	1,5	11,5	Please mention with inquiries and orders	109	LR2+22	10x2,0	68,36	10x16	M4x10	5,2
19 ZR2	21,0	26,0	24	40	25	26	67	16	12	2,0	14,0		120	LR2+50	12x2,0	130	12x18	M4x10	5,2
24 ZR2	60	75	28	55	30	38	86	18	14	2,0	16,0		156	LR2+60	20x3,0	954,9	20x28	M6x18	17,0
28 ZR2	160	200	38	65	35	45	100	20	15	2,5	17,5		177	LR2+70	25x2,5	1811	25x34	M6x18	17,0
38 ZR2	325	405	45	80	45	45	114	24	18	3,0	21,0		192	LR2+90	32x3,5	5167	32x43	M6x18	17,0
42 ZR2	450	560	55	95	50	52	128	26	20	3,0	23,0		214	LR2+100	40x4,0	11870	40x53	M6x18	17,0
48 ZR2	525	655	62	105	56	70	154	28	21	3,5	24,5		261	LR2+112	45x4,0	17486	45x59	M8x22	41,0
55 ZR2	685	825	74	120	65	80	175	30	22	4,0	26,0		288	LR2+130	55x4,0	33543	55x71	M8x22	41,0
65 ZR2	940	1175	80	135	75	80	185	35	26	4,5	30,5	387	LR2+150	60x4,0	44362	60x77	M8x22	41,0	

¹⁾ Other spiders/selection see page 18 et seqq.

²⁾ Depending on hub type. Hub types can be freely selected, for summary see page 124

³⁾ Has to be remachined, if necessary

⁴⁾ Torsion spring stiffness with a length of 1 m of intermediate pipe

For inquiries and orders please specify the shaft distance dimension LR1/LR2 along with the maximum speed to review the critical bending speed. With vertical application a support washer has to be used (please mention in your order).

Ordering example:	ROTEX® GS 24	ZR1	1000 mm	98 Sh-A-GS	1.0 - Ø24		2.5 - Ø24	
	Coupling size	Type	Shaft distance dimension (LR)	Spider hardness	Hub type	Finish bore	Hub type	Finish bore

Type ZR1

- Double- and single-cardanic types

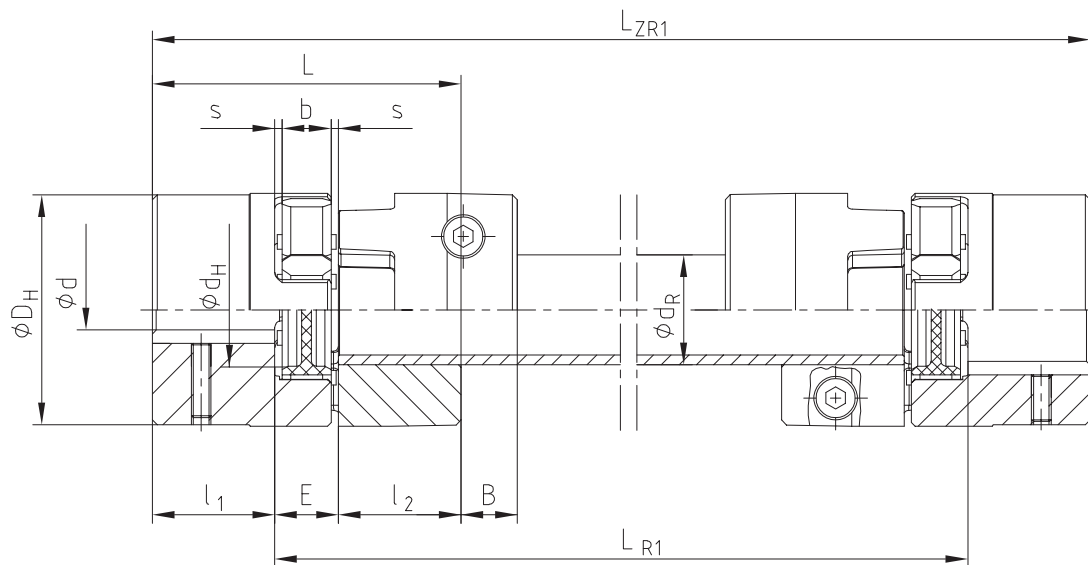

Type ZR2

