

BUMPER

Features

- **Durable NR/SBR rubber** for abrasion resistance and long life
- **Pre-drilled holes** for quick, secure installation
- **Multi-purpose use** for vehicles, warehouses, docks, doors, and furniture

Rectangular Buffer 400L x 80W x 72H

SKU.: 0734071



RS Professionally Approved Products bring to you professional quality parts across all product categories. Our product range has been tested by engineers and provides a comparable quality to the leading brands without paying a premium price.

BUMPER

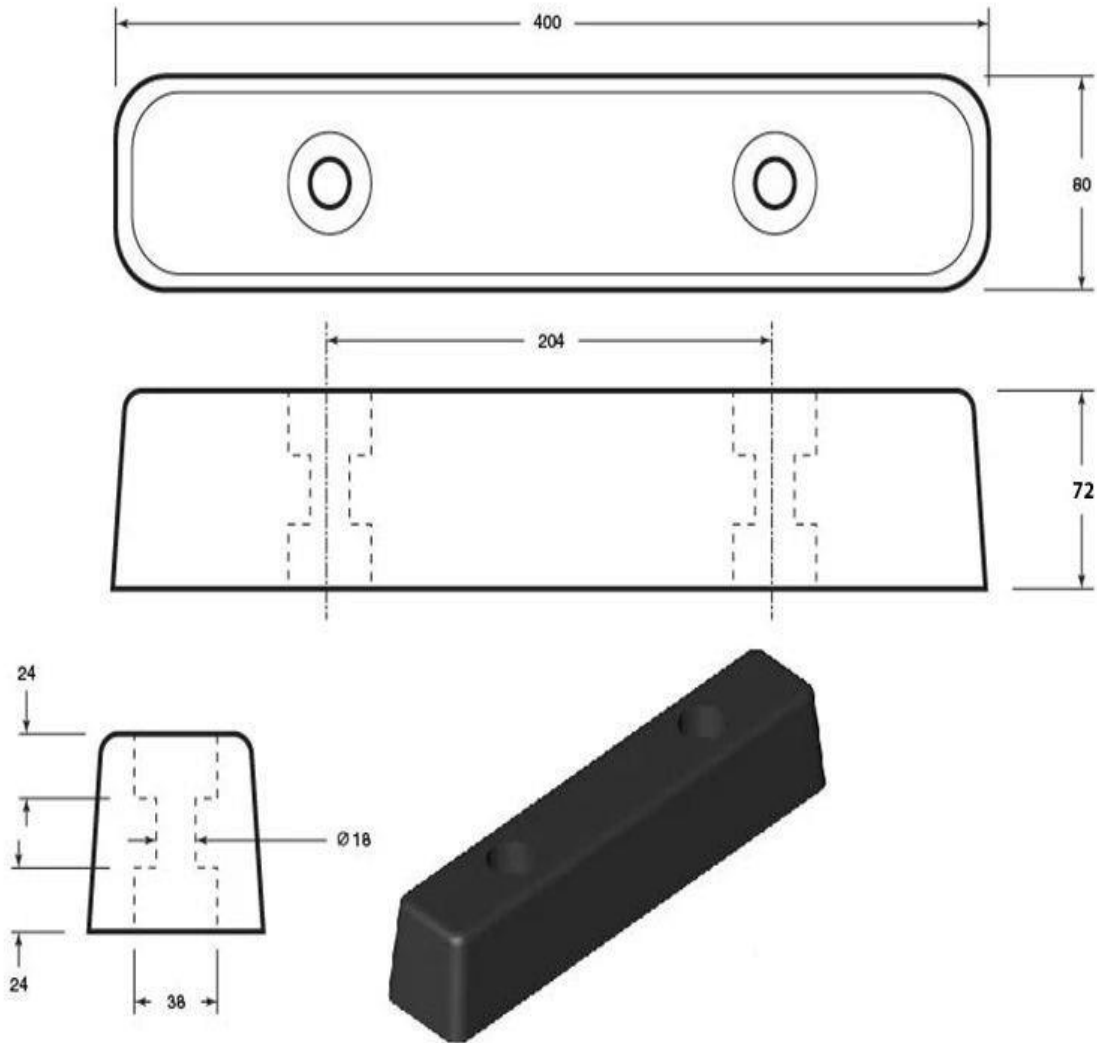

Bumper Dimensions

Length (mm)	400
Width (mm)	80
Height (mm)	72

BUMPER

Product Description

Rectangular Buffers are robust impact-protection solutions manufactured from a durable blend of NR and SBR rubber, engineered to deliver outstanding abrasion resistance, tear strength, and shock absorption in both industrial and everyday environments. Designed to withstand repeated collisions, these heavy-duty rubber bumpers are essential for safeguarding vehicles such as lorries, vans, and trailers during loading and unloading, while also enhancing safety in warehouses by reducing risks from forklift operations. Their versatile design makes them equally effective for protecting delicate glass rack carriers in transit, cushioning impacts in loading bays and docks, and serving as reliable door and furniture buffers to prevent damage in residential or commercial spaces. With pre-drilled countersunk holes for quick and secure installation, these buffers combine durability, functionality, and ease of use, offering a long-lasting solution wherever impact reduction and asset protection are crucial

General Specifications

Material	NR/SBR
Colour	Black

Mechanical Specifications

Weight	1.8KG
Tensile Strength	4Mpa
Elongation	200%
Hardness	75ShA

Operation Environment Specifications

Maximum Temperature	70°C
Minimum Temperature	-15°C