



# SAM R34 Xplained Pro Evaluation Kit (DM320111)

## SAM R34 Xplained Pro User Guide

### Introduction

Microchip's SAM R34 Xplained Pro Evaluation Kit is a hardware platform used to evaluate the ATSAMR34 Low Power LoRa<sup>®</sup> Sub-GHz SiP.

Supported by the Atmel Studio integrated development platform, the kit provides easy access to the features of the SAM R34 SiP and explains how to integrate the device in a custom design.

The Xplained Pro MCU series evaluation kits include an on-board Embedded Debugger, and no external tools are necessary to program or debug the SAM R34 devices.

The Xplained Pro extension kits offer additional peripherals to extend the features of the board and ease the development of custom designs.

**Figure 1. SAM R34 Xplained Pro Evaluation Board (DM320111)**

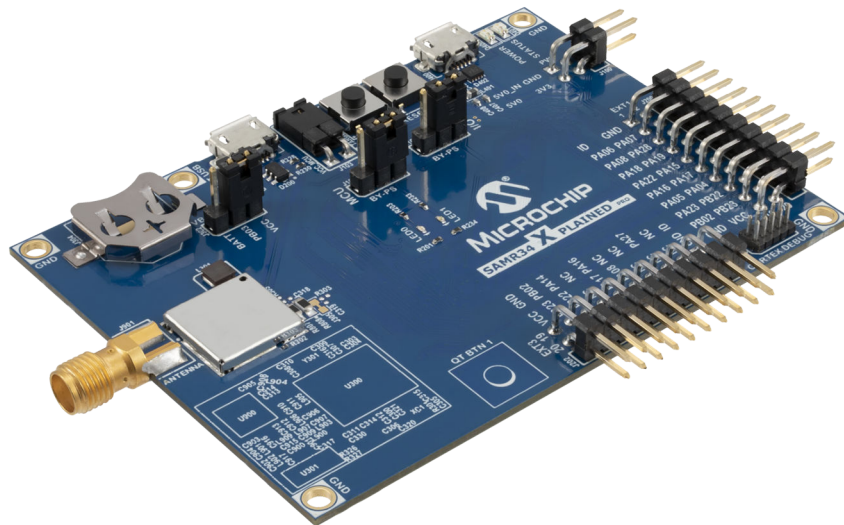

### Features

- SAM R34 SiP with Cortex<sup>®</sup> M0+ CPU and LoRa Transceiver
- Supports 868 MHz and 915 MHz Operation
- On-Board EDBG Debugger and Support for Atmel Studio 7 ICE
- Two Extension Headers for Signal Breakout and Expansion Boards
- On-Board Power Management System with Current Monitoring and USB Power Conditioning
- XPRO Current Measurement System Data Visualizer Support

# SAM R34 Xplained Pro Evaluation Kit...

---

- USB Power Inlet with ESD Protection and Buck Converter
- On-Board TCXO
- Up to +20 dBm Maximum Output Power
- +13 dBm High-Efficiency Operation
- +17 dBm High-Power Operation
- SMA RF Antenna Port with External Whip Antenna Included
- Manual Reset Button
- GPIO Button
- Indicator LEDs for Status and Power
- Auxiliary 10-Pin Cortex Programming Header
- Direct USB Connection to SAM R34 with ESD Protection
- Qtouch<sup>®</sup> Button
- CR1220 Backup Battery Holder
- Supported by Studio 7 Integrated Development Platform
- Software Examples Supported in Advanced Software Framework (ASF)

## Table of Contents

---

Introduction.....	1
Features.....	1
1. Kit Overview.....	5
2. Xplained Pro Getting Started.....	6
2.1. Xplained Pro Quick Start.....	6
2.2. Design Documentation and Relevant Links.....	6
2.3. Chip-Down Design Package .....	7
3. Xplained Pro.....	8
3.1. Xplained Pro.....	8
3.2. Embedded Debugger.....	8
3.3. Xplained Pro Analog Module.....	9
3.4. Hardware Identification System.....	11
3.5. Power Sources.....	11
3.6. Xplained Pro Headers and Connectors.....	12
4. Hardware User Guide.....	15
4.1. Schematics and BOM.....	15
4.2. Power Distribution.....	15
4.3. Connectors.....	16
4.4. Peripherals.....	19
4.5. Embedded Debugger Implementation.....	20
4.6. Kit Modifications.....	24
4.7. Limitations.....	25
5. Agency Certification.....	27
5.1. Antenna Considerations.....	27
5.2. A09-3167 Usage Instructions under Limited Modular Approval (FCC).....	27
5.3. United States.....	27
5.4. Canada.....	28
5.5. Europe.....	30
6. Hardware Revision History.....	31
6.1. Identifying Product ID and Revision.....	31
6.2. Hardware Revision.....	31
7. Document Revision History.....	33
The Microchip Web Site.....	34
Customer Change Notification Service.....	34

# SAM R34 Xplained Pro Evaluation Kit...

---

---

Customer Support.....	34
Microchip Devices Code Protection Feature.....	34
Legal Notice.....	35
Trademarks.....	35
Quality Management System Certified by DNV.....	36
Worldwide Sales and Service.....	37

### 1. Kit Overview

The SAM R34 Xplained Pro Evaluation Kit is a hardware platform used to evaluate the ATSAMR34 Low Power LoRa<sup>®</sup> Sub-GHz SiP module.

The kit offers a set of features that enable the user to get started with the ATSAMR34 Low Power LoRa<sup>®</sup> Sub-GHz SiP peripherals right away, and to understand how to integrate the device in their own design.

The SAM R34 Xplained Pro Evaluation Kit contains the following items:

- One SAM R34 Xplained Pro Evaluation Board
- One external antenna

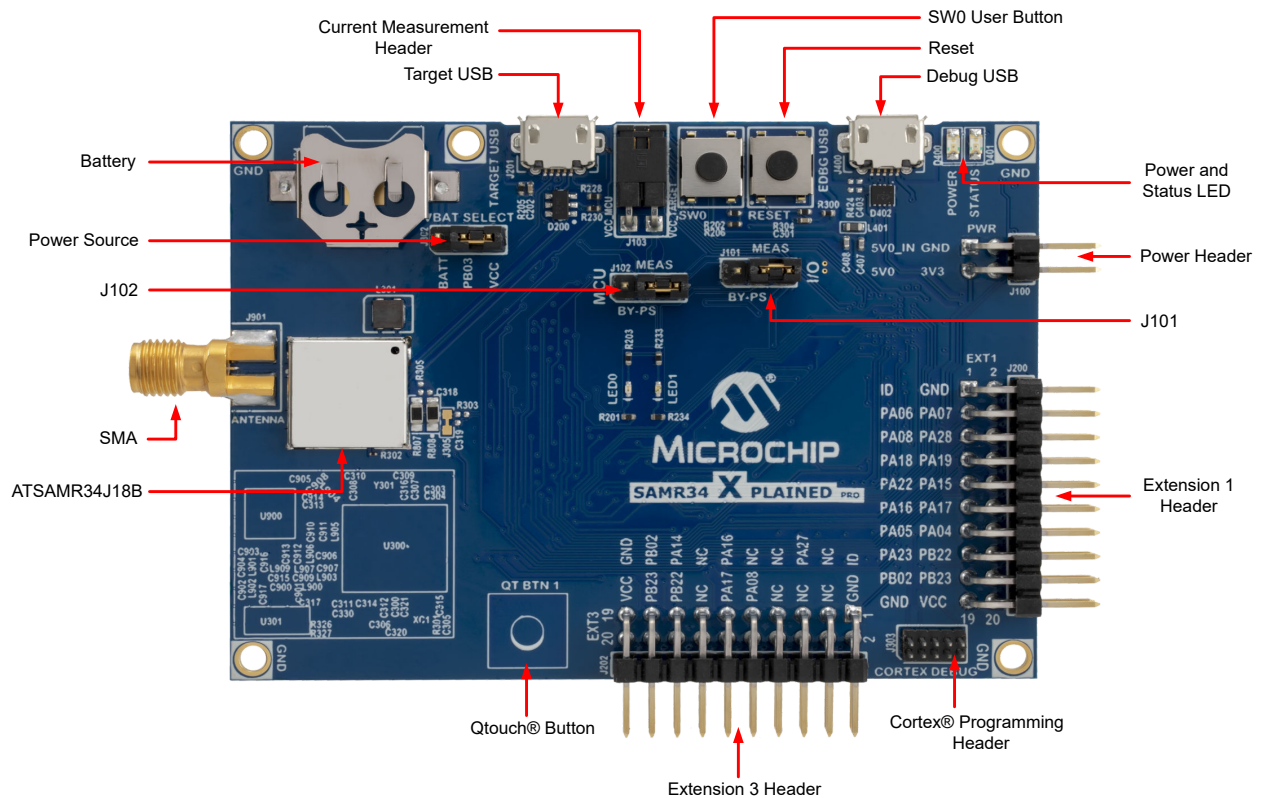

## 2. Xplained Pro Getting Started

### 2.1 Xplained Pro Quick Start

The steps to start exploring the Xplained Pro platform are listed below. See also: [SAM R34 Xplained Pro Evaluation Kit \(DM320111\) Quick Start Guide](#).

1. Download and install Atmel Studio.
2. Launch Atmel Studio.

When the Xplained Pro kit is connected to the computer for the first time, the operating system installs the driver software automatically. This driver supports 32-bit and 64-bit versions of Microsoft® Windows® XP, Windows Vista®, Windows 7, Windows 8, Windows 10, and Windows Server 2012.

When the Xplained Pro board is powered:

- The green power LED D400 is lit
- Atmel Studio automatically detects the connected Xplained Pro and extension board(s)
- In Atmel Studio, the landing page of the kit presents an option to launch the associated ASF. For more details, see the SAM R34 MLS Getting Started Guide (DS50002812).
- The SAM R34 device is programmed and debugged by the on-board Embedded Debugger
- No external programmer or debugger tool is required

### 2.2 Design Documentation and Relevant Links

The following list contains links to the most relevant documents and software for the SAM R34 Xplained Pro Evaluation Kit.

- **Ordering Code** – The SAM R34 Xplained Pro Evaluation Kit can be ordered from [www.microchipdirect.com](http://www.microchipdirect.com) using Ordering Code “DM320111”.
- **Atmel Studio** – Atmel Studio presents Free Atmel IDE for development of C/C++ and assembler code for microcontrollers and relevant documentation.
- **Microchip sample store** – Microchip sample store where samples of devices can be ordered.
- **EDBG User Guide** – User guide containing more information about the on-board Embedded Debugger.
- **Data Visualizer** – Data Visualizer is a program used for processing and visualizing data. Data Visualizer can receive data from various sources such as the Embedded Debugger Data Gateway Interface found on Xplained Pro boards and COM ports.
- **AN2842 SAM R34/R35 RF Hardware Design Guidelines Application Note** – This application note provides the RF design guidelines and circuit optimization techniques to design using the SAM R34. This document is available in the SAM R34 Chip-Down Design Package.
- **SAM R34/R35 Low Power LoRa® Sub-GHz SiP Data Sheet** (DS70005356)
- **SAM R34 MLS Getting Started User Guide** (DS50002812)
- **SAM R34 Xplained Pro Evaluation Kit (DM320111) Quick Start Guide** (DS30010200)
- **SAM L21 Family Data Sheet** (DS60001477A)
- **Semtech SX1276/77/78/79 Data Sheet rev 5**
- **SAM R34 Chip-down Design Package** – Includes SAMR34-XPRO Design Database and MCHPRT Test Application.

### 2.3 Chip-Down Design Package

The [Chip-Down Design Package](#) is a guide for customers wanting to do their own chip-level RF PCB designs. In addition, it contains software tools for manufacturing and regulatory testing. The package includes the following:

- AN2842 RF Hardware Design Guidelines
- Complete CAD source for SAMR34-XPRO
- MCHPRT PC Application for Production and Regulatory Testing
- Example Python<sup>®</sup> scripts
- SAMR34 Radio Utility Firmware

### 3. Xplained Pro

#### 3.1 Xplained Pro

Xplained Pro is an evaluation platform which contains a series of microcontroller boards (evaluation kits) and extension boards. Atmel Studio is used to program and debug the microcontrollers on these boards. Atmel Studio includes Advanced Software Framework (ASF) and Atmel START, which has drivers and demo code, and Data Visualizer, which supports data streaming and advanced debugging. Xplained Pro evaluation kits can be connected to a wide range of Xplained Pro extension boards through standardized headers and connectors. Xplained Pro extension boards have identification (ID) chips to uniquely identify which boards are connected to the Xplained Pro evaluation kits.

#### 3.2 Embedded Debugger

The SAM R34 Xplained Pro contains an Embedded Debugger (EDBG) for on-board debugging. The EDBG is a USB composite device with the following interfaces:

- Debugger
- Virtual COM Port
- Data Gateway Interface (DGI)

The EDBG can program and debug the SAM R34 with the help of Atmel Studio. The Serial Wire Debug (SWD) interface is connected between the EDBG and the SAM R34 on the SAM R34 Xplained Pro.

The Virtual COM Port is connected to a UART on the SAM R34 and provides an easy way to communicate with the target application through terminal software. It offers variable baud rate, parity, and stop bit settings. The settings on the SAM R34 must match the settings given in the terminal software.



**Info:** The Virtual COM Port in the EDBG requires the terminal software to set the Data Terminal Ready (DTR) signal to enable the UART pins connected to the SAM R34. If the DTR signal is not enabled, the UART pins on the EDBG are kept in tri-state (high-Z) to render the COM Port not usable. The DTR signal is automatically set by terminal software, but it may have to be manually enabled in your terminal.

The DGI consists of several physical interfaces for bidirectional communication with the host computer. Communication over the interfaces is bidirectional. It can be used to send event values and data from the SAM R34. Traffic over the interfaces can be timestamped by the EDBG for more accurate tracking of events, but timestamping reduces the maximal data throughput. The [Data Visualizer](#) is used to send and receive data through DGI.

The EDBG controls two LEDs on the SAM R34 Xplained Pro; a power LED and a status LED. The following table provides details on how the LEDs are controlled in different operation modes.

**Table 3-1. EDBG LED Control**

Mode	Power LED	Status LED
Normal mode	The power LED is ON when power is applied to the board.	Activity indicator, the LED flashes when any communication happens to the EDBG.



.....continued		
Mode	Power LED	Status LED
Bootloader mode (idle)	The power LED and the status LED blink simultaneously.	
Bootloader mode (firmware upgrade)	The power LED and the status LED blink in an alternating pattern.	

For additional information on the EDBG, see the [EDBG User Guide](#).

### 3.3 Xplained Pro Analog Module

#### 3.3.1 Overview

The Xplained Pro Analog Module (XAM) extends the embedded debugger with high dynamic range current measurement. This enables power profiling of the target system.

**Figure 3-1. XAM Block Diagram**

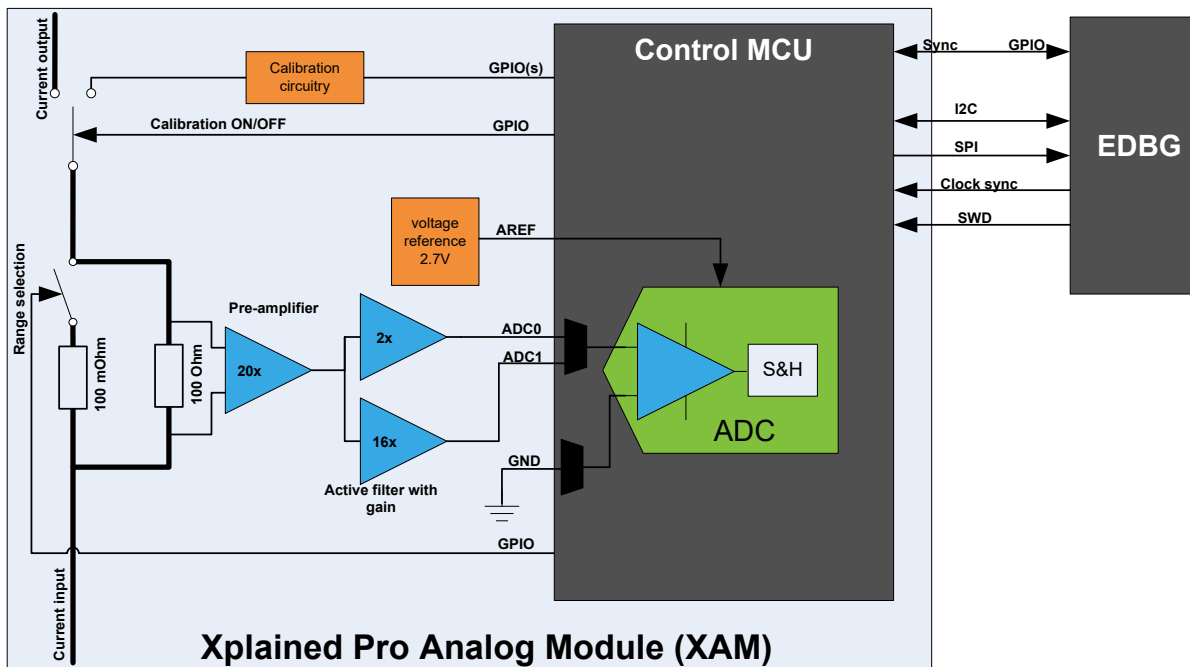

The XAM consists of:

- Calibration circuitry
- Voltage reference circuitry
- Analog front-end:
  - Shunt resistors with a range selection switch
  - Pre-amplifier
  - Two active filters with gain
- Control MCU
  - Analog-to-Digital Converter
  - Signal processing

- Control/communication interface to the EDBG

The current measurement front-end is a high side shunt measurement with a pre-amplifier and a second active filter stage with gain as shown in [Figure 3-1](#). The wide dynamic range is achieved by four measurement ranges, which are defined by two shunt resistors and the two parallel second stage active filters with gain.

### 3.3.2 EDBG Interface

The XAM is connected to the EDBG with the following interfaces:

- **I<sup>2</sup>C**: This is used to control and configure the XAM.
- **SPI**: Current measurement data is streamed to the EDBG via this interface. This is a unidirectional channel from the XAM to the EDBG.
- **SWD**: The MCU in the XAM is programmed via SWD from the EDBG.
- **Clock sync**: Signal used to synchronize ADC measurements with the EDBG.
- **Reference clock**: Reference clock for the XAM.

### 3.3.3 Sample Rate

The raw sampling rate of the XAM is up to 250 kHz and with the default averaging configuration (average of 16 samples), the actual output of the XAM is 16.67 ksps.



**Info:** The XAM output sample rate is not an integer fraction of the raw sampling.

### 3.3.4 Measurement Ranges and Accuracy

The XAM has four measurement ranges. These are defined by two shunt resistors and two gain stages.

**Table 3-2. XAM Measurement Ranges and Accuracy**

Measurement Range	Hardware	Resolution	Accuracy	Comments
Range 1	Low current shunt and high gain stage	20 nA	1 LSB ±1%	Accuracy will decrease below 1 µA. Typical accuracy for 300 nA is 1 LSB ±10%.
Range 2	Low current shunt and low gain stage	150 nA	1 LSB ±1%	
Range 3	High current shunt and high gain stage	10 µA	1 LSB ±1%	
Range 4	High current shunt and low gain stage	100 µA	1 LSB ±1%	Accuracy will decrease above 100 mA. Typical accuracy is 1 LSB ±5% at 400 mA. Maximum current is 400 mA.

The ranges are automatically switched by the XAM to achieve the best measurement results, and the currently active range is visualized in the [Data Visualizer](#) front-end tool. The maximum voltage drop over the shunt resistor is 100 mV, and the XAM switches the range automatically before reaching this limit.

### 3.4 Hardware Identification System

All Xplained Pro extension boards come with an identification chip (ATSHA204A CryptoAuthentication™ chip) to uniquely identify the boards that are connected to the Xplained Pro Evaluation Kit. This chip contains information that identifies the extension with its name and some extra data. When an Xplained Pro extension is connected to an Xplained Pro Evaluation Kit, the information is read and sent to the Atmel Studio. The following table shows the data fields stored in the ID chip with example content.

**Table 3-3. Xplained Pro ID Chip Content**

Data Field	Data Type	Example Content
Manufacturer	ASCII string	Microchip\0'
Product name	ASCII string	Segment LCD1 Xplained Pro\0'
Product revision	ASCII string	02\0'
Product serial number	ASCII string	1774020200000010\0'
Minimum voltage [mV]	uint16_t	3000
Maximum voltage [mV]	uint16_t	3600
Maximum current [mA]	uint16_t	30

### 3.5 Power Sources

The SAM R34 Xplained Pro Evaluation Kit can be powered by several power sources, as listed in the table below.

**Table 3-4. Power Sources for SAM R34 Xplained Pro**

Power input	Voltage requirements	Current requirements	Connector marking
External power	5V ±2% (±100 mV) for USB host operation. 4.3V to 5.5V if USB host operation is not required.	Recommended minimum is 1A to be able to provide enough current for connected USB devices and the board itself. Recommended maximum is 2A due to the input protection maximum current specification.	PWR
Embedded Debugger USB	4.4V to 5.25V (according to USB spec.)	500 mA (according to USB spec.)	DEBUG USB
Target USB	4.4V to 5.25V (according to USB spec.)	500 mA (according to USB spec.)	TARGET USB

The kit will automatically detect which power sources are available and choose which one to use according to the following priority:

1. External power
2. Embedded Debugger USB
3. Target USB

**Note:** If powering the board from the Target USB connector then jumpers J101 and J102 MUST be in the bypass position.



**Info:** External power is required when 500 mA from a USB connector is not enough to power the board with possible extension boards. A connected USB device in a USB host application might easily exceed this limit.

## 3.6 Xplained Pro Headers and Connectors

### 3.6.1 Xplained Pro Standard Extension Header

All Xplained Pro kits have many dual-row, 20-pin, 100 mil extension headers. The Xplained Pro MCU boards have male headers, while the Xplained Pro extensions have their female counterparts. The following table provides the pin description of all the connected pins.



**Info:** Not all pins are always connected on all extension headers.

The extension headers can be used to connect a variety of Xplained Pro extensions to Xplained Pro MCU boards or to access the pins of the target microcontroller on the Xplained Pro boards.

**Table 3-5. Xplained Pro Standard Extension Header**

Pin Number	Pin Name	Description
1	ID	Pin to communicate with the ID chip on an extension board.
2	GND	Ground
3	ADC(+)	Analog-to-Digital Converter; alternatively, a pin for the positive terminal of a differential ADC.
4	ADC(-)	Analog-to-Digital Converter; alternatively, a pin for the negative terminal of a differential ADC.
5	GPIO1	General purpose I/O pin.
6	GPIO2	General purpose I/O pin.
7	PWM(+)	Pulse-Width Modulation; alternatively, a pin for the positive part of a differential PWM.
8	PWM(-)	Pulse-Width Modulation; alternatively, a pin for the negative part of a differential PWM.
9	IRQ/GPIO	Interrupt request pin and/or general purpose I/O pin.

.....continued

Pin Number	Pin Name	Description
10	SPI_SS_B/ GPIO	Slave select pin for Serial Peripheral Interface (SPI) and/or general purpose I/O pin.
11	I <sup>2</sup> C_SDA	Data pin for I <sup>2</sup> C interface. Always connected, bus type.
12	I <sup>2</sup> C_SCL	Clock pin for I <sup>2</sup> C interface. Always connected, bus type.
13	UART_RX	Receiver pin of target device UART.
14	UART_TX	Transmitter pin of target device UART.
15	SPI_SS_A	Slave select for SPI. This pin should preferably not be connected to anything else.
16	SPI_MOSI	SPI master out slave in pin. Always connected, bus type.
17	SPI_MISO	SPI master in slave out pin. Always connected, bus type.
18	SPI_SCK	SPI clock pin. Always connected, bus type.
19	GND	Ground pin for extension boards.
20	VCC	Power pin for extension boards.

### 3.6.2 Xplained Pro Power Header

The power header can be used to connect external power to the SAM R34 Xplained Pro kit. The kit automatically detects and switches to an external power source, if supplied. The power header can also be used to supply power to external peripherals or extension boards. Ensure that the total current does not exceed the recommended current limit of the on-board regulator when using the 3.3V pin.

**Table 3-6. Xplained Pro Power Header**

Pin Number	Pin Name	Description
1	VEXT_P5V0	External 5V input pin
2	GND	Ground pin
3	VCC_P5V0	Unregulated 5V pin (an output, derived from one of the input sources)
4	VCC_P3V3	Regulated 3.3V pin (an output, used as the main power supply for the kit)

### 3.6.3 Interconnect with BTLC1000 XPRO Extension

The SAMR34 SERCOM5 is used for the UART connection to the EXT1 header. For more details, see [Peripherals](#) section. This UART port does not support the CTS/RTS hardware flow-control needed for BTLC1000 operation. To connect SAMR34-XPRO to BTLC1000-XPRO, use SERCOM 5 for the console UART and SERCOM 0 to connect to BTLC1000. The connection mapping is shown in the following table.

**Table 3-7. SAMR34-XPRO to BTLC1000-XPRO Connection Mapping**

SAMR34 XPRO		FTDI TTL-232R-3V3	BTLC1000 XPRO		
PIN	SIGNAL	PLUG RECEPTICAL	J100	PIN	SIGNAL
J200.3	PA06 (S0 UART RTS)		J100.16	16 (UART CTS)	BLE UART RTS/CTS
J200.4	PA07 (S0 UART CTS)		J100.18	18 (UART RTS)	BLE UART RTS/CTS
J200.13	PA05 (S0 UART RXD)		J100.15	15 (UART TXD)	BLE UART
J200.14	PA04 (S0 UART TXD)		J100.17	17 (UART RXD)	BLE UART
J200.5	PA08		J100.3	3	GPIO - WAKEUP PIN
J200.7	PA18		J100.7	7	GPIO - CHIP EN
J200.9	PA22		J100.9	9	IRQ
J200.15	PB02 S5 CONSOLE TXD	5 (Yellow)		FTDI Yellow Cable RXD	Console UART
J200.17	PA23 S5 CONSOLE RXD	4 (Orange)		FTDI Orange Cable TXD	Console UART
J200.19	GND	1 (Black)	J100.19		Power
J200.20	VCC		J100.20		Power

**Note:**

1. SERCOM 5 will be used for console UART.
2. SERCOM 0 will be used for BTLC1000 connection

**Cryptographic and Authentication demos**

Developers using CryptoAuthentication demo boards, such as 88CKSCKT or ECC608, must use EXT3.

## 4. Hardware User Guide

### 4.1 Schematics and BOM

Complete and up-to-date schematics, Bill of Materials (BOM) and design documentation for SAM R43 XPRO is available in the [SAM R34 Chip-Down Design Package](#).

Additionally, this package includes the MCHPRT test firmware, Python scripts and Radio Utility Commands Reference documentation for evaluation and test.

### 4.2 Power Distribution

The SAM R34 Xplained Pro Evaluation Kit can be powered by:

- EDBG USB
- TARGET USB
- External (5V)

The kit has a power mux which automatically chooses the power source if two or all three of the power sources are available to the kit at the same time.

The kit contains:

- Two on-board voltage regulators (3.3V):
  - One for an EDBG and XAM section
  - Another one for SAM R34
- IO peripherals
- Power Measurement Section (XAM)

**Figure 4-1. Power Supply Block Diagram**

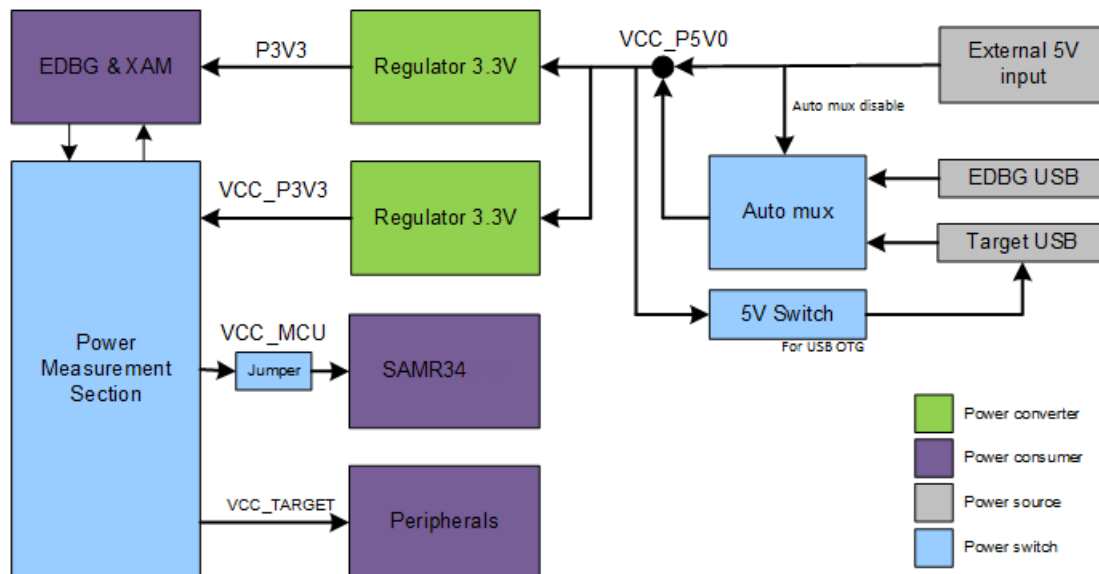

### 4.3 Connectors

The following sections describe the implementation of the relevant connectors and headers on the SAM R34 Xplained Pro Evaluation Kit and their connection to the SAM R34. The tables of connections in the sections also describe which signals are shared between the headers and on-board functionality.

#### 4.3.1 Xplained Pro Extension Headers

The SAM R34 Xplained Pro Evaluation Kit headers EXT1 and EXT3 offer access to the I/O of the microcontroller in order to expand the board e.g., by connecting extensions to the board. These headers are based on the standard extension header specified in [3.6.1 Xplained Pro Standard Extension Header](#). The headers have a pitch of 2.54 mm.

**Table 4-1. Extension Header EXT1**

EXT1		SAM R34		Shared Functionality
Pin	Signal	Port	Pin	
1	ID	-	-	-
2	GND	-	-	-
3	ADC(+)	PA06	E3	-
4	ADC(-)	PA07	F3	-
5	GPIO1	PA08	F4	EXT3
6	GPIO2	PA28	C6	<a href="#">4.4.2 Mechanical Buttons</a>
7	PWM(+)	PA18	E7	-
8	PWM(-)	PA19	E8	-
9	IRQ	PA22	D8	-
10	SPI_SS	PA15	G8	-
11	TWI_SDA	PA16	F7	EXT3
12	TWI_SCL	PA17	E6	EXT3
13	UART_RX	PA05	C4	<a href="#">4.5.2 Virtual COM Port</a>
14	UART_TX	PA04	D3	<a href="#">4.5.2 Virtual COM Port</a>
15	SPI_SS	PA23	D7	-
16	SPI_MOSI	PB22	E5	EXT3
17	SPI_MISO	PB02	B4	EXT3
18	SPI_SCK	PB23	C7	EXT3
19	GND	-	-	-
20	VCC	-	-	-



**Table 4-2. Extension Header EXT3**

EXT3		SAM R34		Shared Functionality
Pin	Signal	Port	Pin	
1	ID	-	-	-
2	GND	-	-	-
3	ADC(+)	-	-	-
4	ADC(-)	-	-	-
5	GPIO1	PA27	E4	-
6	GPIO2	-	-	-
7	PWM(+)	-	-	-
8	PWM(-)	-	-	-
9	IRQ	-	-	-
10	SPI_SS	PA08	F4	EXT1
11	TWI_SDA	PA16	F7	EXT1
12	TWI_SCL	PA17	E6	EXT1
13	UART_RX	-	-	-
14	UART_TX	-	-	-
15	SPI_SS	PA14	F8	-
16	SPI_MOSI	PB22	E5	EXT1
17	SPI_MISO	PB02	B4	EXT1
18	SPI_SCK	PB23	C7	EXT1
19	GND	-	-	-
20	VCC	-	-	-

### 4.3.2 Direct USB Connection

For USB applications on SAM R34, there is a directly connected USB port designated TARGET\_USB. This is exposed as a Micro-B jack designated J201. The TARGET\_USB port includes required ESD suppression and power management circuitry. A GPIO is used to detect the VBUS voltage on the connector, to detect when a TARGET USB cable is connected in Self-Powered mode. In USB Host mode, VBUS voltage is provided by the kit and cannot identify the connected device; therefore, another GPIO is used to detect the USB ID of the device.

**Note:** The SAMR35 does not have a USB PHY. The EDBG port is not directly connected to the SAM R34 USB PHY.

**Table 4-3. USB Connections**

SAM R34 Pin	USB Function	Shared Functionality
PA07	VBUS Detection	EXT1

.....continued

SAM R34 Pin	USB Function	Shared Functionality
PA15	USB ID	EXT3
PA24	USB D-	-
PA25	USB D+	-

### 4.3.3 Current Measurement Header

A right-angled 1x2, 100 mil pin header marked with the MCU current measurement is located at the upper edge of the SAM R34 Xplained Pro. All power to the SAM R34 is exclusively routed through this header (excluding power to extension headers and peripherals). To measure the power consumption of the device, remove the jumper and replace it with an ammeter.



Removing the jumper from the pin header while the kit is powered may cause the SAM R34 to be powered through its I/O pins. This may cause permanent damage to the device.

### 4.3.4 Cortex Debug Connector

SAM R34 Xplained Pro Evaluation Kit has a 10-pin 50-mil Cortex Debug Connector that can be used to attach external debuggers to the SAM R34.

**Table 4-4. Cortex Debug Connector**

Cortex Debug Connector pin	Pin / Net	Function	Shared functionality
1	VCC_TARGET_P3V3	SAM R34 voltage	-
2	PA31_SWDIO	SWD data signal	<a href="#">4.5.1 Serial Wire Debug</a>
3	GND	Ground	-
4	PA30_SWDCLK	SWD clock signal	<a href="#">4.5.1 Serial Wire Debug</a>
5	GND	Ground	-
6	-	-	-
7	-	-	-
8	-	-	-
9	GND	Ground	-
10	RESET*	Target reset signal	<a href="#">4.4.2 Mechanical Buttons</a>

**Note:** The target reset (RESET\* pin on the ATSAMR34 Low Power LoRa<sup>®</sup> Sub-GHz SiP) is isolated from the Cortex Debug Connector by R300 (0 Ohm link) which is not mounted by default in the PCBA.

## 4.4 Peripherals

### 4.4.1 External Clock

The SAM R34 Xplained Pro Evaluation Kit contains one mounted 32.768 kHz crystal that can be used as a clock source for the SAM R34. The RF transceiver uses a 32 MHz external TCXO for optimal performance at long range.

**Table 4-5. External Clock**

SAM R34 pin	Function
A3	PA00_XIN32
A4	PA01_XOUT32

**Table 4-6. External TCXO**

SAM R34 pin	Function
H6	RF_XTA
H7	NC

### 4.4.2 Mechanical Buttons

SAM R34 Xplained Pro Evaluation Kit contains two mechanical buttons:

- RESET button connected to the SAM R34 reset line
  - When the RESET button is pressed it drives the I/O line to ground
- Generic user configurable button
  - When the user button is pressed it drives the I/O line to target voltage

**Note:** There is no pull-up resistor connected to the generic user button. Remember to enable the internal pull up in the SAM R34 to use the button.

**Table 4-7. Mechanical Buttons**

SAM R34 pin	Silkscreen text	Shared functionality
RESET*	RESET	<a href="#">4.5.1 Serial Wire Debug</a>
PA28	SW0	EXT1

### 4.4.3 LEDs

There is one yellow LED available on the SAM R34 Xplained Pro board that can be turned on and off. The LED can be activated by driving the connected I/O line to GND.

**Table 4-8. LED Connections**

SAM R34 Pin	Function	Shared Functionality
PA19	Yellow LED0	EXT1
PA18	Green LED1	EXT1

### 4.4.4 UART Connection

The SAM R34 Xplained Pro Evaluation Kit exposes the UART on EXT1. This is useful for command line interfaces, debugging and application layer code.



**Info:** The TXD/RXD UART signals exposed on EXT1 are connected to SERCOM 5 which is in low-power domain PD0. Because of low-power constraints, SERCOM 5 does not support CTS/RTS flow-control signals.

The following table provides the UART signals pin description.

**Table 4-9. UART Signals Pin Description**

SAM R34 pin	Function	Shared Functionality
D3	PA04_S0_UART_TX	EXT1, EDBG
C4	PA05_S0_UART_RX	EXT1, EDBG

### 4.4.5 CryptoAuthentication Device

The SAM R34 Xplained Pro Evaluation Kit has a depopulated socket for ATECC608 Security IC. This is reserved for future revisions of the board.

### 4.4.6 QTouch Button

The SAM R34 Xplained Pro Evaluation Board contains a self-capacitance button, which can be used as an I/O. This QTouch button is intended to be driven by the built-in Peripheral Touch Controller (PTC) of the device. A zero ohm resistor is added on the board to easily disconnect the on-board touch buttons from the extension header since the I/O lines are shared between the QTouch button and extension header 1 (EXT1).



**note:** To get started with QTouch, refer to the [QTouch® Library](#) and [QTouch® Composer](#).

**Table 4-10. QTouch Connection**

SAM R34 Pin	Silkscreen Text	Shared Functionality
PA06	QT BTN1	<a href="#">EXT1</a>

### 4.4.7 Backup Battery

The SAM R34 Xplained Pro Evaluation Kit is equipped with a CR1220 backup battery holder. This provides 35 mAH of power for SRAM Backup.

**Note:** To comply with shipping regulations, Lithium batteries are not included in this product.

## 4.5 Embedded Debugger Implementation

The SAM R34 Xplained Pro Evaluation Kit contains an Embedded Debugger (EDBG) that can be used to program and debug the SAM R34 using Serial Wire Debug (SWD). The Embedded Debugger also includes a Virtual Com port interface over UART, a Data Gateway Interface (DGI) over SPI, and I<sup>2</sup>C, and also includes four of the SAM R34 GPIOs. The kit also includes a XAM extension processor to the

Embedded Debugger for on-board current measurement. Atmel Studio can be used as a front-end for the Embedded Debugger.

### 4.5.1 Serial Wire Debug

The Serial Wire Debug (SWD) uses two pins to communicate with the target. For further information on how to use the programming and debugging capabilities of the EDBG, see [3.2 Embedded Debugger](#).

**Table 4-11. SWD Connections**

SAM R34 pin	Function
PA30	SWD clock
PA31	SWD data

### 4.5.2 Virtual COM Port

The Embedded Debugger acts as a Virtual Com Port gateway by using one of the SAM R34 UARTs. For further information on how to use the Virtual COM port, see [3.2 Embedded Debugger](#).

**Table 4-12. Virtual COM Port Connections**

SAM R34 pin	Function	Shared functionality
PA05	RX line	EXT1, EXT3
PA04	TX line	EXT1, EXT3

### 4.5.3 Data Gateway Interface

The Embedded Debugger features a Data Gateway Interface (DGI) by using either an SPI or I<sup>2</sup>C. The DGI can be used for sending data from the SAM R34 to the host PC. For further information on how to use the DGI interface, refer to the [Data Visualizer](#) and the [EDBG User Guide](#).

**Table 4-13. DGI Interface Connections When Using SPI**

SAM R34 Pin	Function	Shared Functionality
PA27	GPIO/SPI SS (Slave Select) (SAM R34 is Master)	-
PB02	SERCOM5 PAD[0] SPI MISO (Master In, Slave Out)	<a href="#">EXT1</a> and <a href="#">EXT3</a>
PB22	SERCOM5 PAD[2] SPI MOSI (Master Out, Slave in)	<a href="#">EXT1</a> and <a href="#">EXT3</a>
PB23	SERCOM5 PAD[3] SPI SCK (Clock Out)	<a href="#">EXT1</a> and <a href="#">EXT3</a>

**Table 4-14. DGI Interface Connections When Using I<sup>2</sup>C**

SAM R34 Pin	Function	Shared Functionality
PA16	SERCOM1 PAD[0] SDA (Data line)	<a href="#">EXT1</a> and <a href="#">EXT3</a>
PA17	SERCOM1 PAD[1] SCL (Clock line)	<a href="#">EXT1</a> and <a href="#">EXT3</a>

Three GPIO lines are connected to the Embedded Debugger. The EDBG can monitor these lines and time stamp pin value changes. This makes it possible to accurately timestamp events in the SAM R34

application code. For further information on how to configure and use the GPIO monitoring features, refer to the [Data Visualizer](#) and the [EDBG User Guide](#).

**Table 4-15. GPIO Lines Connected to the EDBG**

SAM R34 Pin	Function	Shared Functionality
PA08	GPIO0	<a href="#">EXT3</a>
PA09	GPIO1	-
PA14	GPIO3	<a href="#">EXT3</a>

#### 4.5.4 SAM R34 Xplained Pro Evaluation Kit XAM Configuration

On the SAM R34 Xplained Pro Evaluation Kit the MCU and the MCU peripherals (e.g., extensions) are powered by their own regulator, as shown in the following figure. All other parts of the board, mainly the Embedded Debugger and accompanying Xplained Pro Analog Module (XAM), are powered from a separate regulator. The current to the MCU and peripherals can be measured by connecting them to the XAM output through jumper settings.

Figure 4-2. SAM R34 XAM Implementation Block Diagram

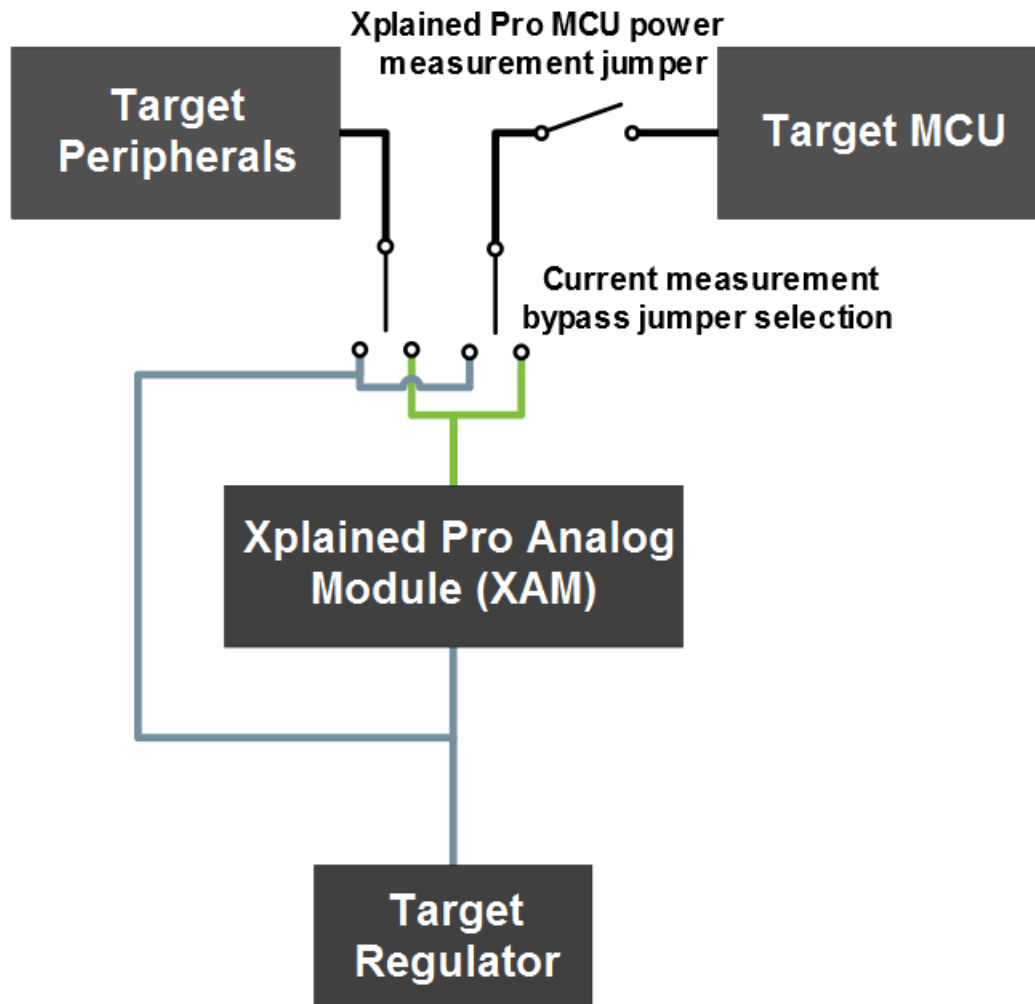

On the SAM R34 Xplained Pro Evaluation Kit, the XAM can be used in four configurations:

1. **No current measurement or external MCU current measurement:** The XAM is bypassed and thus the MCU and peripherals are supplied directly by the regulator. Set both jumpers in the "BYPASS" position. In this configuration it is also possible to connect external measurement tools on the Xplained Pro MCU power measurement header to measure MCU current directly instead of using the XAM.
2. **MCU current measurement:** The XAM measures only the MCU current while the peripherals are supplied directly by the regulator. For this configuration, place the jumper for "I/O" (peripherals) into the "BYPASS" position and the for "MCU" into the "MEASURE" position.
3. **Peripherals measurement:** The XAM measures only the peripherals current while the MCU is directly supplied by the regulator. For this configuration, place the jumper for "MCU" into the "BYPASS" position and the "I/O" jumper into the "MEASURE" position.
4. **MCU and peripherals measurement:** In this configuration both MCU and peripherals are measured by the XAM. Place both jumpers on "I/O" and "MCU" headers in the "MEASURE" position.

### 4.6 Kit Modifications

The SAM R34 Xplained Pro Evaluation Kit contains several resistors that can be used to disconnect I/O pins of the SAM R34 SiP from connectors and on-board ICs, and to disconnect power signals.

**Table 4-16. EDBG Disconnect Resistors**

Designator	Value	From	To	Comment
R322	0R	EDBG SWDIO	PA31 SWDIO	Debug interface from the EDBG to the SAM R34
R323	0R	EDBG SWDCLK	PA30 SWCLK	
R324	0R	EDBG TARGET RESET	TARGET MCU RESET	
R310	0R	EDBG SPI SS	PA27 GPIO	EDBG CDC and DGI interfaces to the SAM R34
R311	0R	EDBG SPI SCK	PB23 SPI SCK	
R312	0R	EDBG SPI MOSI	PB22 SPI MOSI	
R313	0R	EDBG SPI MISO	PB02 SPI MISO	
R314	0R	EDBG DGI SDA	PA16 I2C SDA	
R315	0R	EDBG DGI SCL	PA17 I2C SCL	
R316	0R	EDBG CDC RX	PA04 UART TX	
R317	0R	EDBG CDC TX	PA05 UART RX	
R318	0R	EDBG DGI_GPIO0	PA08 GPIO	
R319	0R	EDBG DGI_GPIO1	PA09 GPIO	
R320	0R	EDBG DGI_GPIO2	PA12 GPIO	
R321	0R	EDBG DGI_GPIO3	PA14 GPIO	
R229	0R	TARGET VUSB DETECT	PA07 ADC7	Used to detect if a USB cable is connected to the TARGET USB connector.
R109	47K	VCC_P3V3_CM_IN	TARGET VOLTAGE	Used in the voltage divider network to detect the target voltage of 3.3V.
R325	0R	RESET	TARGET RESET SENSE	Reset sense signal to EDBG, used to detect external resets.

#### 4.6.1 Operating at Other Voltages

The SAM R34 Xplained Pro board operates at 3.3V by default, but it is also possible to run the board at lower voltages from an external supply. The EDBG is designed to run from a 3.3V supply and won't work on other voltages; therefore, all connections from the EDBG and from the on-board 3.3V regulator to the SAM R34 SoC must be removed.

To completely disconnect the EDBG and the on-board power supply from the SAM R34 SoC, do the following:



- Remove the two jumpers from the on-board 3-pin current measurement headers (J101 and J102), and connect the two center pins (pin 2) together with a wire or an ammeter as shown in [Figure 4-3](#).
- Remove all the EDGB disconnect resistors (refer to [Table 4-16](#)).
- Power ON the SAM R34 Xplained Pro via pin 4 (3V3) and pin 2 (GND) of the Power Header J100.
- Program SAM R34 using industry standard 2x5 50-mil Cortex Debug Connector and external programmer such as Atmel ICE.



**Info:** Operating the SAM R34 SiP at voltages other than 3.3V requires physical modifications on the kit using a soldering iron and an external debugger for programming the SAM R34 SiP. The on-board current measurement only works at 3.3V. The on-board LED is selected for 3.3V operation; the LED brightness at 1.8V operation is dull. To increase the emitted light level, the value of the series resistor can be lowered. EDBG functionality can be restored by re-soldering the removed components.



The voltage supplied through the power header is applied directly to the SAM R34 SoC and the extension headers. Applying a voltage greater than 3.3V may damage the board permanently.

**Figure 4-3. SAM R34 Xplained Pro Current Measurement Headers**

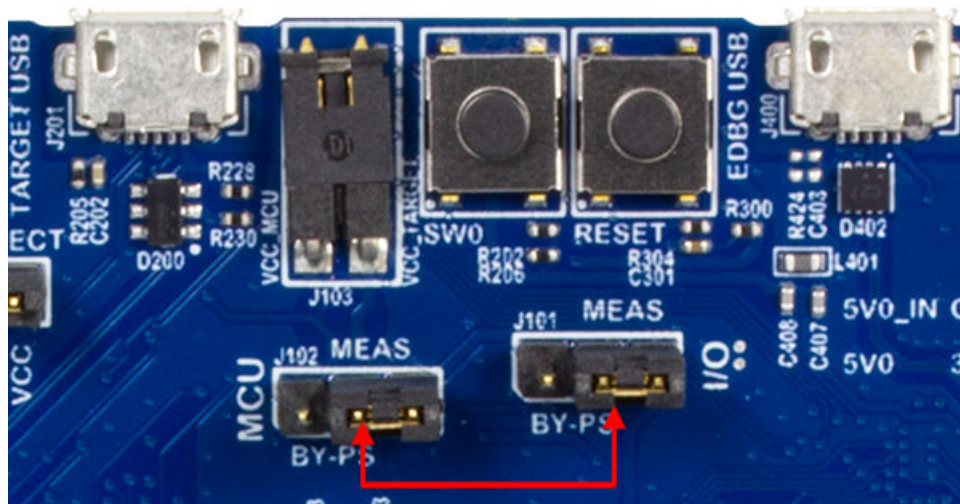

### Related Links

[3.6.2 Xplained Pro Power Header](#)

[4.3.4 Cortex Debug Connector](#)

## 4.7 Limitations

The SAM R34 Xplained Pro Evaluation Kit is optimized for operation in the 902-928 and 868 MHz bands. The RF signal path is not designed to operate in the 470 MHz band. The RFI\_LF and RFO\_LF signals are not connected. Contact Microchip technical support for advice on 470 MHz band operation.

The XPRO system includes an RF Switch and a Temperature Controlled Crystal Oscillator (TCXO). The TCXO is required to achieve the exceptionally low receiver-sensitivity and generous link-budget. The RF switch directs TX/RX signal flow in the RF signal path. It also allows users to evaluate both the high-

power PA\_BOOST and high-efficiency RFO\_HF modes. Both the TCXO and RF Switch consume additional power when compared to the SAMR34 Data Sheet specifications. The additional consumption needs to be factored into laboratory measurements with the SAM R34 XPRO. See the following table for details.

**Table 4-17. SAM R34 Xplained Pro Evaluation Kit Additional Power Consumers**

REF_DES	Description	MFG	MPN	Typical Sleep Current	Typical Active Current
U900	RF Switch	Skyworks	SKY13373-460LF	5 $\mu$ A	60 $\mu$ A
XC1	TCXO	Epson	TG2016SMN	N/A	1.8 mA

## 5. Agency Certification

This equipment (SAM R34 Xplained Pro Evaluation Kit / A09-3167) is intended for evaluation purposes only. The following regulatory notices are to cover the requirements under the regulatory approval.

### 5.1 Antenna Considerations

The following table provides the list of approved antennas along with the manufacturer and part number details.

**Table 5-1. A09-3167 with Antenna Types**

S. No.	Part Number	Vendor	Antenna Gain at 824 ~ 960 MHz Band	Antenna Type
1	AL-A80355-UB701	Alead Technology	2 dBi	Dipole

### 5.2 A09-3167 Usage Instructions under Limited Modular Approval (FCC)

When used in USA and Canada, the Evaluation Kit will only work on the 902-928 MHz Frequency band, with hopping activated if the 125 kHz channels are enabled.

The host product manufacturer must ensure that the RF behavior adheres to the certification (e.g. FCC, ISED) requirements when the module is installed in the final host product.

### 5.3 United States

The A09-3167 module has received Federal Communications Commission (FCC) CFR47 Telecommunications, Part 15 Subpart C “Intentional Radiators” limited single-modular approval in accordance with Part 15.212 Modular Transmitter approval.

The user must comply with all of the instructions provided by the Grantee, which indicate installation and/or operating conditions necessary for compliance.

#### 5.3.1 Labeling and User Information Requirements

The A09-3167 has been labeled with their own FCC ID number. If the FCC ID is not visible when the module is installed inside another device, then the outside of the finished product into which the module is installed must display a label referring to the enclosed module. This exterior label can use wording as follows:

For the A09-3167:

**Contains Transmitter Module FCC ID: 2ADHKA093167**

or

**Contains FCC ID: 2ADHKA093167**

**This device complies with Part 15 of the FCC Rules. Operation is subject to the following two conditions: (1) this device may not cause harmful interference, and (2) this device must accept any interference received, including interference that may cause undesired operation.**

A user's manual for the finished product should include the following statement:

This equipment has been tested and found to comply with the limits for a Class B digital device, pursuant to part 15 of the FCC Rules. These limits are designed to provide reasonable protection against harmful

interference in a residential installation. This equipment generates, uses and can radiate radio frequency energy, and if not installed and used in accordance with the instructions, may cause harmful interference to radio communications. However, there is no guarantee interference will not occur in a particular installation. If this equipment does cause harmful interference to radio or television reception, which can be determined by turning the equipment off and on, the user is encouraged to try to correct the interference by one or more of the following measures:

- Reorient or relocate the receiving antenna
- Increase the separation between the equipment and receiver
- Connect the equipment into an outlet on a circuit different from that to which the receiver is connected
- Consult the dealer or an experienced radio/TV technician for help

Additional information on labeling and user information requirements for Part 15 devices can be found in KDB Publication 784748, which is available at the FCC Office of Engineering and Technology (OET) Laboratory Division Knowledge Database (KDB) <https://apps.fcc.gov/oetcf/kdb/index.cfm>

### 5.3.2 RF Exposure

All transmitters regulated by FCC must comply with RF exposure requirements. KDB 447498 General RF Exposure Guidance provides guidance in determining whether proposed or existing transmitting facilities, operations or devices comply with limits for human exposure to Radio Frequency (RF) fields adopted by the Federal Communications Commission (FCC).

From the FCC Grant: Output power listed is conducted.

This transmitter is restricted for use with the specific antenna(s) tested in this application for Certification and must not be co-located or operating in conjunction with any other antenna or transmitters within a host device, except in accordance with FCC multi-transmitter product procedures. The antenna of this transmitter must be installed to provide a separation distance of at least 20 cm from all persons.

### 5.3.3 Information for the OEMs or Integrators

This grant is valid only when the device is sold to OEM integrators and installation is done under the control of the Grantee.

### 5.3.4 Approved Antenna Types

To maintain modular approval in the United States, only the antenna types that have been tested shall be used.

Antennas approved for A09-3167 with the antenna types are listed in [Table 5-1](#).

### 5.3.5 Helpful Web Sites

Federal Communications Commission (FCC): <http://www.fcc.gov>

FCC Office of Engineering and Technology (OET) Laboratory Division Knowledge Database (KDB):  
<https://apps.fcc.gov/oetcf/kdb/index.cfm>

## 5.4 Canada

The A09-3167 has been certified for use in Canada under Innovation, Science and Economic Development Canada (ISED, formerly Industry Canada) Radio Standards Procedure (RSP) RSP-100, Radio Standards Specification (RSS) RSS-Gen and RSS-247.

### 5.4.1 Labeling and User Information Requirements

Label Requirements (from RSP-100 Issue 11, Section 3): The host device shall be properly labeled to identify the module within the host device.

The Innovation, Science and Economic Development Canada certification label of a module shall be clearly visible at all times when installed in the host device, otherwise the host device must be labeled to display the Innovation, Science and Economic Development Canada certification number of the module, preceded by the words “Contains”, or similar wording expressing the same meaning, as follows:

For the A09-3167:

#### **Contains IC: 20266-093167**

User Manual Notice for License-Exempt Radio Apparatus (from Section 8.4 RSS-Gen, Issue 5, April 2018): User manuals for license-exempt radio apparatus shall contain the following or equivalent notice in a conspicuous location in the user manual or alternatively on the device or both:

**This device contains licence-exempt transmitter(s)/receiver(s) that comply with Innovation, Science and Economic Development Canada’s licence-exempt RSS(s). Operation is subject to the following two conditions:**

**(1) This device may not cause interference;**

**(2) This device must accept any interference, including interference that may cause undesired operation of the device.**

**L’émetteur/récepteur exempt de licence contenu dans le présent appareil est conforme aux CNR d’Innovation, Sciences et Développement économique Canada applicables aux appareils radio exempts de licence. L’exploitation est autorisée aux deux conditions suivantes:**

- **L’appareil ne doit pas produire de brouillage;**
- **L’appareil doit accepter tout brouillage radioélectrique subi, même si le brouillage est susceptible d’en compromettre le fonctionnement.**

Transmitter Antenna (From Section 6.8 RSS-GEN, Issue 5, April 2018): User manuals, for transmitters shall display the following notice in a conspicuous location:

**This radio transmitter [IC: 20266-093167] has been approved by Innovation, Science and Economic Development Canada to operate with the antenna types listed below, with the maximum permissible gain indicated. Antenna types not included in this list that have a gain greater than the maximum gain indicated for any type listed are strictly prohibited for use with this device.**

**Le présent émetteur radio [IC: 20266-093167] a été approuvé par Innovation, Sciences et Développement économique Canada pour fonctionner avec les types d’antenne énumérés ci-dessous et ayant un gain admissible maximal. Les types d’antenne non inclus dans cette liste, et dont le gain est supérieur au gain maximal indiqué pour tout type figurant sur la liste, sont strictement interdits pour l’exploitation de l’émetteur.**

Immediately following the above notice, the manufacturer shall provide a list of all antenna types which can be used with the transmitter, indicating the maximum permissible antenna gain (in dBi) and the required impedance for each antenna type.

### 5.4.2 RF Exposure

All transmitters regulated by ISED must comply with RF exposure requirements listed in RSS-102 - Radio Frequency (RF) Exposure Compliance of Radio communication Apparatus (All Frequency Bands).

This transmitter is restricted for use with a specific antenna tested in this application for certification, and must not be co-located or operating in conjunction with any other antenna or transmitters within a host device, except in accordance with Canada multi-transmitter product procedures.

The installation of the transmitter must ensure compliance is demonstrated according to the ISED SAR procedures.

### 5.4.3 Helpful Websites

Industry Canada: <http://www.ic.gc.ca/>

## 5.5 Europe

This equipment (A09-3167) has been assessed under the Radio Equipment Directive (RED) for use in European Union countries. A Declaration of Conformity must be issued for each of these standards and kept on file as described in Radio Equipment Directive.

Furthermore, the manufacturer must maintain a copy of the module's documentation and ensure the final product does not exceed the specified power ratings, antenna specifications, and/or installation requirements as specified in the user manual. If any of these specifications are exceeded in the final product, a submission must be made to a notified body for compliance testing to all required standards.



#### **Important:**

On account of the nature of radio equipment, the height of the CE marking affixed to radio equipment may be lower than 5 mm, provided that it remains visible and legible.

More detailed information about CE marking requirements, refer [Article 19](#) of "DIRECTIVE 2014/53/EU OF THE EUROPEAN PARLIAMENT AND OF THE COUNCIL" of 16 April 2014.

---

#### SIMPLIFIED EU DECLARATION OF CONFORMITY

Hereby, Microchip Technology Inc. declares that the radio equipment type [A09-3167] is in compliance with Directive 2014/53/EU.

The full text of the EU declaration of conformity is available at the following internet address (refer product specific pages): <http://www.microchip.com/design-centers/wireless-connectivity/>

## 6. Hardware Revision History

### 6.1 Identifying Product ID and Revision

There are two ways to find the revision and product identifier of the Xplained Pro boards: either through Atmel Studio or by looking at the sticker on the bottom side of the PCB.

When an Xplained Pro MCU board is connected to a computer with Atmel Studio running, an information window with the serial number is shown. The first six digits of the serial number contain the product identifier and revision. Information about connected Xplained Pro extension boards is also shown in the window.

The same information can be found on the sticker on the bottom side of the PCB. Most kits have stickers that have the identifier and revision printed in plain text as A09-nnnn/rr, where nnnn is the identifier and rr is the revision. Boards with limited space have a sticker with only a data matrix code, which contains a serial number string.

The serial number string has the following format:

```
"nnnnrrssssssss"
```

n = product identifier

r = revision

s = serial number

The product identifier for the SAM R34 Xplained Pro is A09-3167.

### 6.2 Hardware Revision

#### Revision 1

This is an internal release of a small lot for engineering validation testing.

#### Revision 2

This is an internal release of a small lot for regulatory pre-testing.

#### Revision 3

This is the first public release. This revision contains known errors on the silkscreen. The reference designators for EXT1.15 and EXT1.10 are mismarked. For extension header (EXT1) pin details, see [Table 4-1](#). Revision 3 may be identified on the bottom side silkscreen as shown in the following image.

**Figure 6-1. Bottom Side of Silkscreen**



# SAM R34 Xplained Pro Evaluation Kit...

## Hardware Revision History

---

### Revision 4

This revision is the second public release. Silkscreen errors were corrected. Revision 4 PCB may be identified by the markings shown below.

**Figure 6-2. Revision 4 Bottom Side Silkscreen**





**7. Document Revision History**

Revision	Date	Section	Description
C	05/2019	Introduction	Updated Figure 1.
		Kit Overview	Updated image.
		Hardware Revision History	Added Revision 4 description and image.
B	03/2019	Limitations	Added a new section.
		Reference Schematics	Added a new section.
		Bill of Materials	Added a new section.
A	10/2018	Document	Initial Release

## The Microchip Web Site

---

Microchip provides online support via our web site at <http://www.microchip.com/>. This web site is used as a means to make files and information easily available to customers. Accessible by using your favorite Internet browser, the web site contains the following information:

- **Product Support** – Data sheets and errata, application notes and sample programs, design resources, user's guides and hardware support documents, latest software releases and archived software
- **General Technical Support** – Frequently Asked Questions (FAQ), technical support requests, online discussion groups, Microchip consultant program member listing
- **Business of Microchip** – Product selector and ordering guides, latest Microchip press releases, listing of seminars and events, listings of Microchip sales offices, distributors and factory representatives

## Customer Change Notification Service

---

Microchip's customer notification service helps keep customers current on Microchip products. Subscribers will receive e-mail notification whenever there are changes, updates, revisions or errata related to a specified product family or development tool of interest.

To register, access the Microchip web site at <http://www.microchip.com/>. Under "Support", click on "Customer Change Notification" and follow the registration instructions.

## Customer Support

---

Users of Microchip products can receive assistance through several channels:

- Distributor or Representative
- Local Sales Office
- Field Application Engineer (FAE)
- Technical Support

Customers should contact their distributor, representative or Field Application Engineer (FAE) for support. Local sales offices are also available to help customers. A listing of sales offices and locations is included in the back of this document.

Technical support is available through the web site at: <http://www.microchip.com/support>

## Microchip Devices Code Protection Feature

---

Note the following details of the code protection feature on Microchip devices:

- Microchip products meet the specification contained in their particular Microchip Data Sheet.
- Microchip believes that its family of products is one of the most secure families of its kind on the market today, when used in the intended manner and under normal conditions.
- There are dishonest and possibly illegal methods used to breach the code protection feature. All of these methods, to our knowledge, require using the Microchip products in a manner outside the operating specifications contained in Microchip's Data Sheets. Most likely, the person doing so is engaged in theft of intellectual property.
- Microchip is willing to work with the customer who is concerned about the integrity of their code.

- Neither Microchip nor any other semiconductor manufacturer can guarantee the security of their code. Code protection does not mean that we are guaranteeing the product as “unbreakable.”

Code protection is constantly evolving. We at Microchip are committed to continuously improving the code protection features of our products. Attempts to break Microchip’s code protection feature may be a violation of the Digital Millennium Copyright Act. If such acts allow unauthorized access to your software or other copyrighted work, you may have a right to sue for relief under that Act.

## Legal Notice

---

Information contained in this publication regarding device applications and the like is provided only for your convenience and may be superseded by updates. It is your responsibility to ensure that your application meets with your specifications. MICROCHIP MAKES NO REPRESENTATIONS OR WARRANTIES OF ANY KIND WHETHER EXPRESS OR IMPLIED, WRITTEN OR ORAL, STATUTORY OR OTHERWISE, RELATED TO THE INFORMATION, INCLUDING BUT NOT LIMITED TO ITS CONDITION, QUALITY, PERFORMANCE, MERCHANTABILITY OR FITNESS FOR PURPOSE. Microchip disclaims all liability arising from this information and its use. Use of Microchip devices in life support and/or safety applications is entirely at the buyer’s risk, and the buyer agrees to defend, indemnify and hold harmless Microchip from any and all damages, claims, suits, or expenses resulting from such use. No licenses are conveyed, implicitly or otherwise, under any Microchip intellectual property rights unless otherwise stated.

## Trademarks

---

The Microchip name and logo, the Microchip logo, AnyRate, AVR, AVR logo, AVR Freaks, BitCloud, chipKIT, chipKIT logo, CryptoMemory, CryptoRF, dsPIC, FlashFlex, flexPWR, Heldo, JukeBlox, KeeLoq, Kleer, LANCheck, LINK MD, maXStylus, maXTouch, MediaLB, megaAVR, MOST, MOST logo, MPLAB, OptoLyzer, PIC, picoPower, PICSTART, PIC32 logo, Prochip Designer, QTouch, SAM-BA, SpyNIC, SST, SST Logo, SuperFlash, tinyAVR, UNI/O, and XMEGA are registered trademarks of Microchip Technology Incorporated in the U.S.A. and other countries.

ClockWorks, The Embedded Control Solutions Company, EtherSynch, Hyper Speed Control, HyperLight Load, IntelliMOS, mTouch, Precision Edge, and Quiet-Wire are registered trademarks of Microchip Technology Incorporated in the U.S.A.

Adjacent Key Suppression, AKS, Analog-for-the-Digital Age, Any Capacitor, AnyIn, AnyOut, BodyCom, CodeGuard, CryptoAuthentication, CryptoAutomotive, CryptoCompanion, CryptoController, dsPICDEM, dsPICDEM.net, Dynamic Average Matching, DAM, ECAN, EtherGREEN, In-Circuit Serial Programming, ICSP, INICnet, Inter-Chip Connectivity, JitterBlocker, KleerNet, KleerNet logo, memBrain, Mindi, MiWi, motorBench, MPASM, MPF, MPLAB Certified logo, MPLIB, MPLINK, MultiTRAK, NetDetach, Omniscient Code Generation, PICDEM, PICDEM.net, PICKit, PICtail, PowerSmart, PureSilicon, QMatrix, REAL ICE, Ripple Blocker, SAM-ICE, Serial Quad I/O, SMART-I.S., SQI, SuperSwitcher, SuperSwitcher II, Total Endurance, TSHARC, USBCheck, VariSense, ViewSpan, WiperLock, Wireless DNA, and ZENA are trademarks of Microchip Technology Incorporated in the U.S.A. and other countries.

SQTP is a service mark of Microchip Technology Incorporated in the U.S.A.

Silicon Storage Technology is a registered trademark of Microchip Technology Inc. in other countries.

GestIC is a registered trademark of Microchip Technology Germany II GmbH & Co. KG, a subsidiary of Microchip Technology Inc., in other countries.

All other trademarks mentioned herein are property of their respective companies.

© 2019, Microchip Technology Incorporated, Printed in the U.S.A., All Rights Reserved.

ISBN: 978-1-5224-4456-5

## Quality Management System Certified by DNV

---

### ISO/TS 16949

Microchip received ISO/TS-16949:2009 certification for its worldwide headquarters, design and wafer fabrication facilities in Chandler and Tempe, Arizona; Gresham, Oregon and design centers in California and India. The Company's quality system processes and procedures are for its PIC<sup>®</sup> MCUs and dsPIC<sup>®</sup> DSCs, KEELOQ<sup>®</sup> code hopping devices, Serial EEPROMs, microperipherals, nonvolatile memory and analog products. In addition, Microchip's quality system for the design and manufacture of development systems is ISO 9001:2000 certified.

## Worldwide Sales and Service

AMERICAS	ASIA/PACIFIC	ASIA/PACIFIC	EUROPE
<p><b>Corporate Office</b> 2355 West Chandler Blvd. Chandler, AZ 85224-6199 Tel: 480-792-7200 Fax: 480-792-7277 Technical Support: <a href="http://www.microchip.com/support">http://www.microchip.com/support</a> Web Address: <a href="http://www.microchip.com">www.microchip.com</a></p> <p><b>Atlanta</b> Duluth, GA Tel: 678-957-9614 Fax: 678-957-1455</p> <p><b>Austin, TX</b> Tel: 512-257-3370</p> <p><b>Boston</b> Westborough, MA Tel: 774-760-0087 Fax: 774-760-0088</p> <p><b>Chicago</b> Itasca, IL Tel: 630-285-0071 Fax: 630-285-0075</p> <p><b>Dallas</b> Addison, TX Tel: 972-818-7423 Fax: 972-818-2924</p> <p><b>Detroit</b> Novi, MI Tel: 248-848-4000</p> <p><b>Houston, TX</b> Tel: 281-894-5983</p> <p><b>Indianapolis</b> Noblesville, IN Tel: 317-773-8323 Fax: 317-773-5453 Tel: 317-536-2380</p> <p><b>Los Angeles</b> Mission Viejo, CA Tel: 949-462-9523 Fax: 949-462-9608 Tel: 951-273-7800</p> <p><b>Raleigh, NC</b> Tel: 919-844-7510</p> <p><b>New York, NY</b> Tel: 631-435-6000</p> <p><b>San Jose, CA</b> Tel: 408-735-9110 Tel: 408-436-4270</p> <p><b>Canada - Toronto</b> Tel: 905-695-1980 Fax: 905-695-2078</p>	<p><b>Australia - Sydney</b> Tel: 61-2-9868-6733</p> <p><b>China - Beijing</b> Tel: 86-10-8569-7000</p> <p><b>China - Chengdu</b> Tel: 86-28-8665-5511</p> <p><b>China - Chongqing</b> Tel: 86-23-8980-9588</p> <p><b>China - Dongguan</b> Tel: 86-769-8702-9880</p> <p><b>China - Guangzhou</b> Tel: 86-20-8755-8029</p> <p><b>China - Hangzhou</b> Tel: 86-571-8792-8115</p> <p><b>China - Hong Kong SAR</b> Tel: 852-2943-5100</p> <p><b>China - Nanjing</b> Tel: 86-25-8473-2460</p> <p><b>China - Qingdao</b> Tel: 86-532-8502-7355</p> <p><b>China - Shanghai</b> Tel: 86-21-3326-8000</p> <p><b>China - Shenyang</b> Tel: 86-24-2334-2829</p> <p><b>China - Shenzhen</b> Tel: 86-755-8864-2200</p> <p><b>China - Suzhou</b> Tel: 86-186-6233-1526</p> <p><b>China - Wuhan</b> Tel: 86-27-5980-5300</p> <p><b>China - Xian</b> Tel: 86-29-8833-7252</p> <p><b>China - Xiamen</b> Tel: 86-592-2388138</p> <p><b>China - Zhuhai</b> Tel: 86-756-3210040</p>	<p><b>India - Bangalore</b> Tel: 91-80-3090-4444</p> <p><b>India - New Delhi</b> Tel: 91-11-4160-8631</p> <p><b>India - Pune</b> Tel: 91-20-4121-0141</p> <p><b>Japan - Osaka</b> Tel: 81-6-6152-7160</p> <p><b>Japan - Tokyo</b> Tel: 81-3-6880-3770</p> <p><b>Korea - Daegu</b> Tel: 82-53-744-4301</p> <p><b>Korea - Seoul</b> Tel: 82-2-554-7200</p> <p><b>Malaysia - Kuala Lumpur</b> Tel: 60-3-7651-7906</p> <p><b>Malaysia - Penang</b> Tel: 60-4-227-8870</p> <p><b>Philippines - Manila</b> Tel: 63-2-634-9065</p> <p><b>Singapore</b> Tel: 65-6334-8870</p> <p><b>Taiwan - Hsin Chu</b> Tel: 886-3-577-8366</p> <p><b>Taiwan - Kaohsiung</b> Tel: 886-7-213-7830</p> <p><b>Taiwan - Taipei</b> Tel: 886-2-2508-8600</p> <p><b>Thailand - Bangkok</b> Tel: 66-2-694-1351</p> <p><b>Vietnam - Ho Chi Minh</b> Tel: 84-28-5448-2100</p>	<p><b>Austria - Wels</b> Tel: 43-7242-2244-39 Fax: 43-7242-2244-393</p> <p><b>Denmark - Copenhagen</b> Tel: 45-4450-2828 Fax: 45-4485-2829</p> <p><b>Finland - Espoo</b> Tel: 358-9-4520-820</p> <p><b>France - Paris</b> Tel: 33-1-69-53-63-20 Fax: 33-1-69-30-90-79</p> <p><b>Germany - Garching</b> Tel: 49-8931-9700</p> <p><b>Germany - Haan</b> Tel: 49-2129-3766400</p> <p><b>Germany - Heilbronn</b> Tel: 49-7131-67-3636</p> <p><b>Germany - Karlsruhe</b> Tel: 49-721-625370</p> <p><b>Germany - Munich</b> Tel: 49-89-627-144-0 Fax: 49-89-627-144-44</p> <p><b>Germany - Rosenheim</b> Tel: 49-8031-354-560</p> <p><b>Israel - Ra'anana</b> Tel: 972-9-744-7705</p> <p><b>Italy - Milan</b> Tel: 39-0331-742611 Fax: 39-0331-466781</p> <p><b>Italy - Padova</b> Tel: 39-049-7625286</p> <p><b>Netherlands - Drunen</b> Tel: 31-416-690399 Fax: 31-416-690340</p> <p><b>Norway - Trondheim</b> Tel: 47-72884388</p> <p><b>Poland - Warsaw</b> Tel: 48-22-3325737</p> <p><b>Romania - Bucharest</b> Tel: 40-21-407-87-50</p> <p><b>Spain - Madrid</b> Tel: 34-91-708-08-90 Fax: 34-91-708-08-91</p> <p><b>Sweden - Gothenberg</b> Tel: 46-31-704-60-40</p> <p><b>Sweden - Stockholm</b> Tel: 46-8-5090-4654</p> <p><b>UK - Wokingham</b> Tel: 44-118-921-5800 Fax: 44-118-921-5820</p>