

THIS DRAWING IS UNPUBLISHED. RELEASED FOR PUBLICATION
 © COPYRIGHT - By - ALL RIGHTS RESERVED.

LOC	DIST	REVISIONS					
FT	0	P	LTR	DESCRIPTION	DATE	DWN	APVD
		AY1		REVISED PER ECO-11-004587	11MAR11	RK	HMR

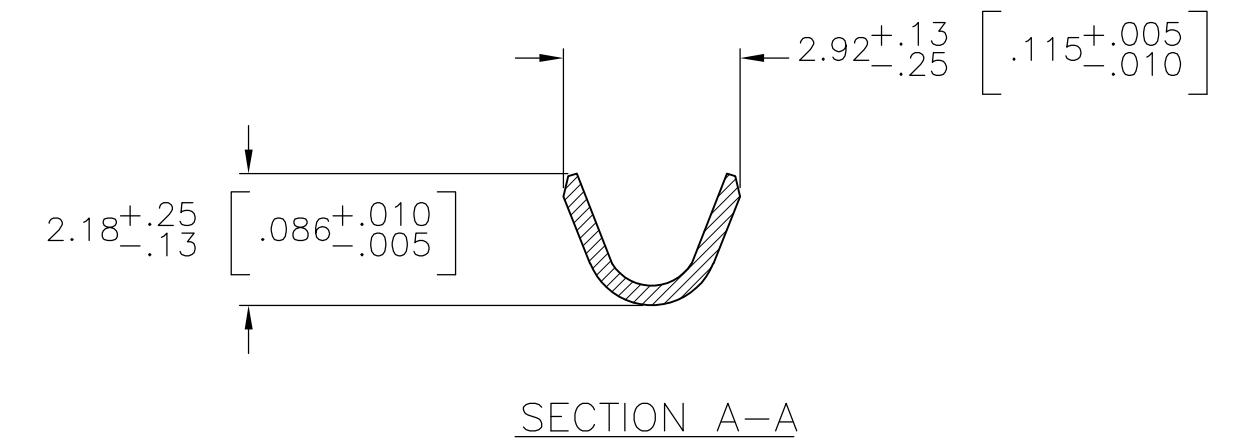

$\phi 1.689 \pm .051$ [$\phi 0.665 \pm .0020$]

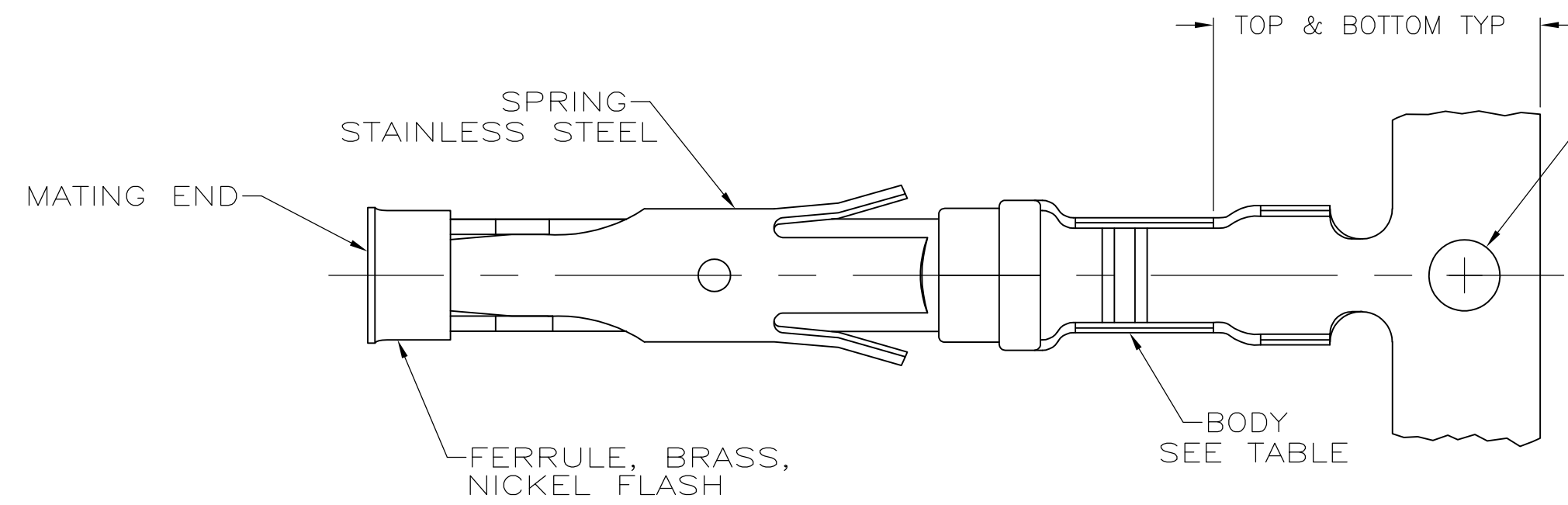
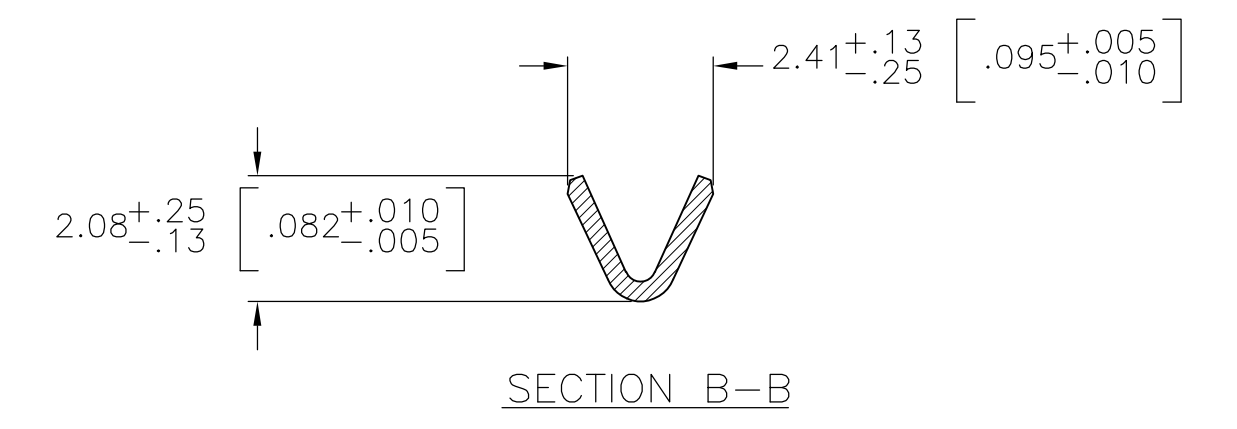
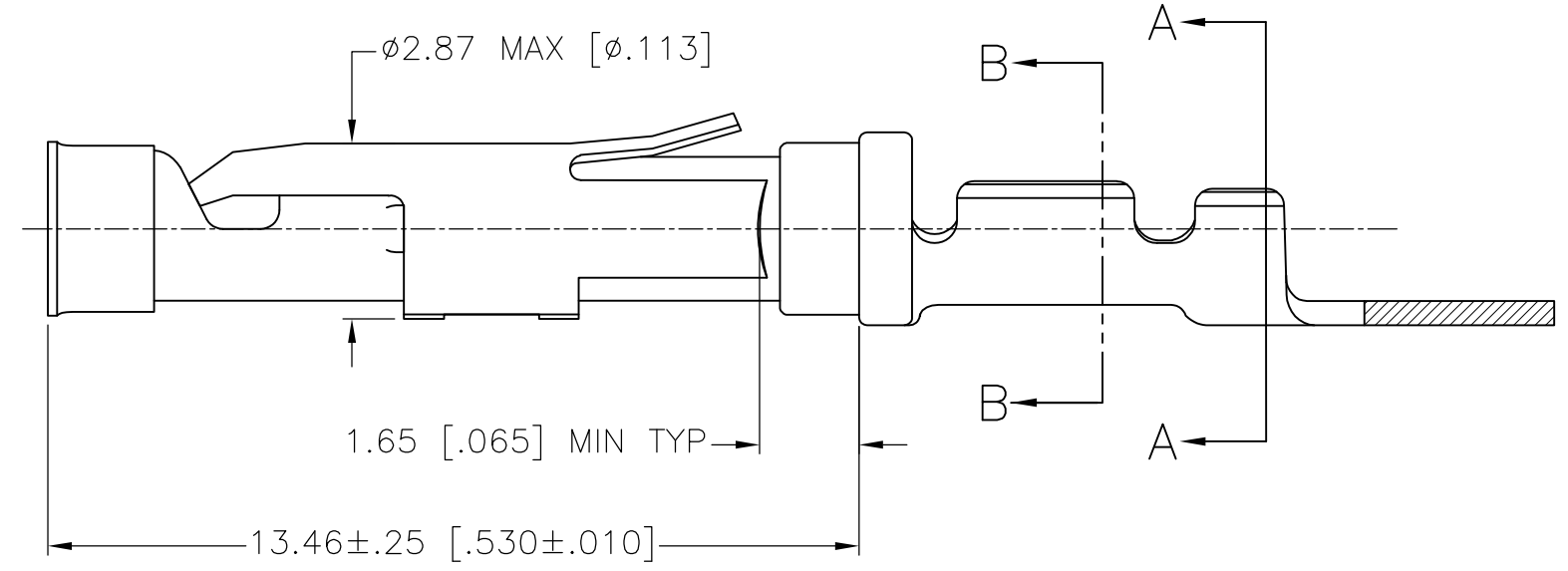
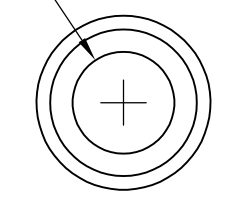

- 1 0.76µm [.000030] MIN GOLD PER MIL-G-45204 ON MATING END FOR A LENGTH OF 5.08 [.200] MIN WITH GOLD FLASH ON THE REMAINDER OVER 0.76µm [.000030] MIN NICKEL PER QQ-N-290.
- 2 1.27µm [.000050] MIN TIN-LEAD PER MIL-T-10727 OVER 0.76µm [.000030] MIN NICKEL PER QQ-N-290.
- 3 0.76µm [.000030] MIN GOLD PER MIL-G-45204 ON MATING END FOR A LENGTH OF 5.08 [.200] MIN WITH A UNIFORM GRADIENT TO 0.25 [.000010] MIN GOLD PER MIL-G-45204 ON THE REMAINDER OVER 0.76µm [.000030] NICKEL PER QQ-N-290.
- 4 0.38µm [.000015] MIN GOLD PER MIL-G-45204 ON MATING END FOR A LENGTH OF 5.08 [.200] MIN WITH GOLD FLASH ON THE REMAINDER OVER 0.76µm [.000030] MIN NICKEL PER QQ-N-290.
- 5 1.27µm [.000050] MIN GOLD PER MIL-G-45204 ON MATING END FOR A LENGTH OF 5.08 [.200] MIN WITH GOLD FLASH ON REMAINDER OVER 1.90µm [.000075] MIN NICKEL PER QQ-N-290.
- 6 0.15µm [.000020] MIN GOLD PER MIL-G-45204 ON MATING END FOR A LENGTH OF 5.08 [.200] MIN WITH GOLD FLASH ON REMAINDER OVER 1.27µm [.000050] MIN NICKEL PER QQ-N-290.
- 7 GOLD PLATING NEED NOT APPEAR IN THIS AREA EXCEPT 1-66104-6 & 1-66104-7 HAVE GOLD PLATING ON INSULATION BARREL.
- 8 REVERSE REELED FOR MINI-APPLICATOR.
- 9 WIRE RANGE 24-20 AWG. INSULATION RANGE 1.02 [.040]-2.03 [.080].
- 10 0.38µm [.000015] MIN GOLD PER MIL-G-45204 ON MATING END FOR A LENGTH OF 5.08 [.200] MIN, 1.27µm [.000050] MIN TIN-LEAD PER MIL-T-10727 FOR A LENGTH OF 5.69 [.224] MIN ON OPPOSITE END, BOTH OVER 1.27µm [.000050] MIN NICKEL PER QQ-N-290 ON ENTIRE CONTACT.
- 11 0.76µm [.000030] MIN GOLD PER MIL-G-45204 ON MATING END FOR A LENGTH OF 5.08 [.200] MIN WITH GOLD FLASH ON THE REMAINDER OVER 1.27µm [.000050] MIN NICKEL PER QQ-N-290.
- 12 1.27µm [.000050] MIN TIN PER MIL-T-10727 OVER .076µm [.000030] MIN NICKEL PER QQ-N-290.
- 13 0.38µm [.000015] MIN GOLD PER MIL-G-45204 ON MATING END FOR A LENGTH OF 5.08 [.200] MIN, 1.27µm [.000050] MIN TIN PER MIL-T-10727 FOR A LENGTH OF 5.69 [.224] MIN ON OPPOSITE END, BOTH OVER 1.27µm [.000050] MIN NICKEL PER QQ-N-290 ON ENTIRE CONTACT.
- 15 2.54µm [.000100] MIN SILVER OVER 0.76µm [.000030] MIN NICKEL PER QQ-N-290
- 16 OBSOLETE PARTS: OBSOLETE CIS STREAMLINING PER D.RENAUD/D.SINISI
- 17 SUPERCEDED BY 3-66104-2

REV	DESCRIPTION	DATE	BY	CHKD	APVD	REASON
8	15					BRASS
8	13					BRASS
8	12					BRASS
8	12					BRASS
STANDARD	12					BRASS
14	11					BRASS
OBSOLETE	10					BRASS
8	2					BRASS
OBSOLETE	1					PHOSPHOR BRONZE
OBSOLETE	2					PHOSPHOR BRONZE
OBSOLETE	6					BRASS
OBSOLETE	5					BRASS
OBSOLETE	5					BRASS
8	1					BRASS
8	4					BRASS
8	2					BRASS
8	3					BRASS
STANDARD	1					BRASS
STANDARD	4					BRASS
STANDARD	2					BRASS
STANDARD	3					BRASS
REELING	FINISH					BRASS

THIS DRAWING IS A CONTROLLED DOCUMENT.

DWN V. FURLER 22JUL2003
 CHK G. STEINHAEUER 22JUL03
 APVD G. STEINHAEUER 22JUL03

TE TE Connectivity

NAME: SOCKET ASSEMBLY, .062 TYPE III+

SIZE: A2 CAGE CODE: 00779 DRAWING NO: 66104 RESTRICTED TO: -

MATERIAL: SEE CALLOUTS FINISH: SEE CALLOUTS WEIGHT: - SCALE: 8:1 SHEET: 1 OF 1 REV: AY1

CUSTOMER DRAWING