

DRAWING MADE IN THIRD ANGLE PROJECTION
 © COPYRIGHT 1977 BY AMP INCORPORATED, HARRISBURG, PA.
 ALL INTERNATIONAL RIGHTS RESERVED. AMP INCORPORATED PRODUCTS
 COVERED BY U. S. AND FOREIGN PATENTS AND/OR PATENTS PENDING.

1 SHEET METAL SCREWS NOT SUPPLIED
 2 TWO REQUIRED PER CONNECTOR.
 3 FOR USE WITH 2,3,4 CIRCUIT HOUSINGS WITH A MAXIMUM
 WIRE BUNDLE DIAMETER OF 5/16".

		REVISIONS			LOC	DIST
P	F	ZONE	LTR	DESCRIPTION	DATE	APPROVED
✓	✓		C	REV PER EC0730-0201-94	4-25-80	JH RS
✓						
✓						

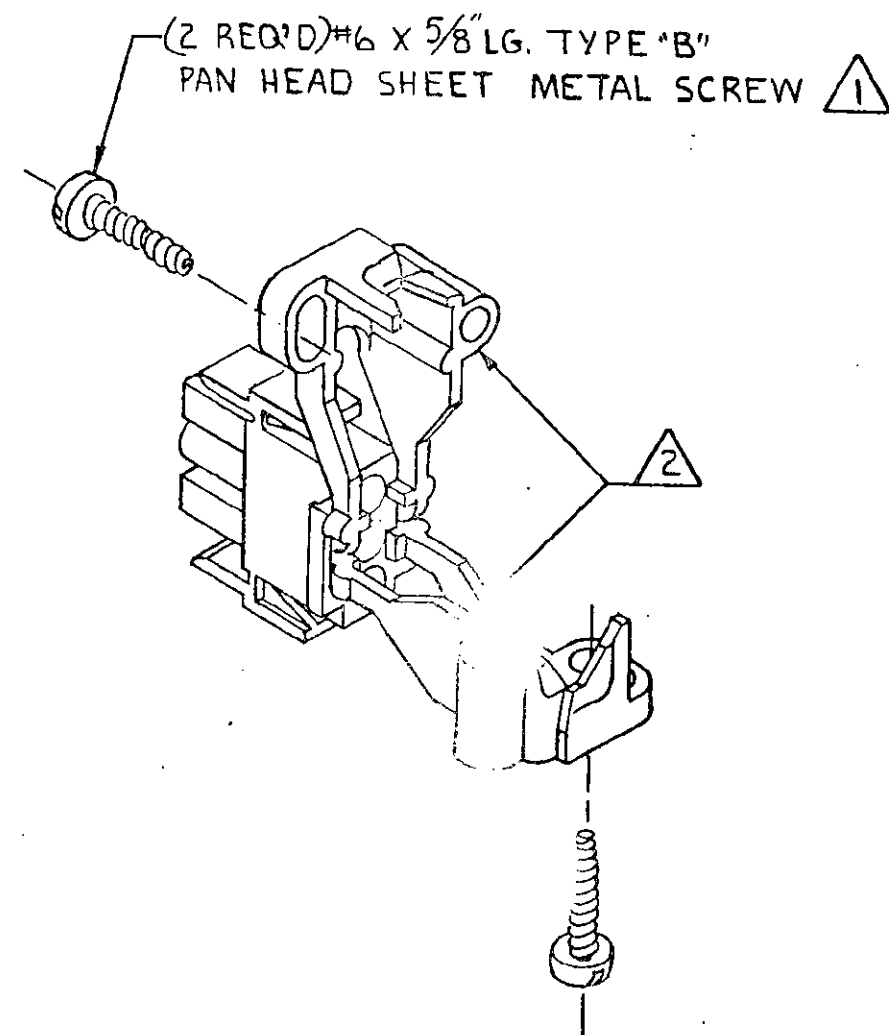
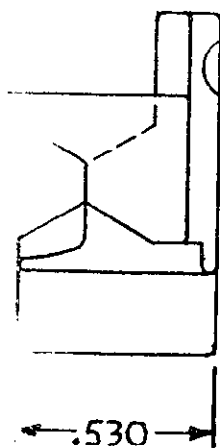
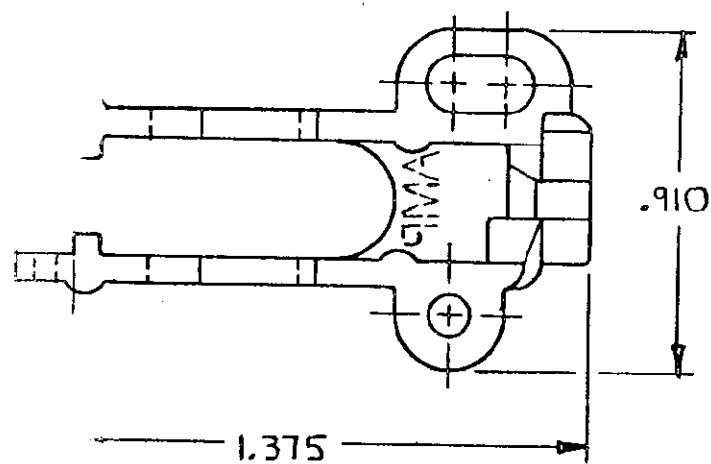
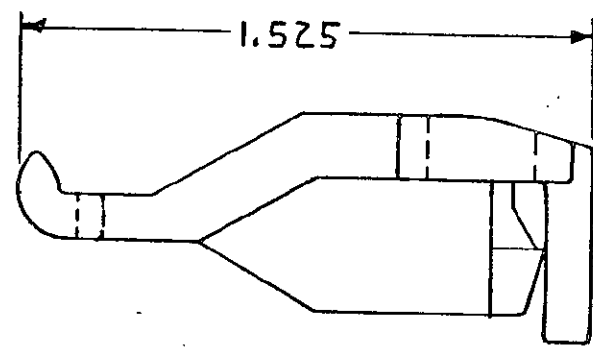

350811-1

PART NC

UNLESS OTHERWISE SPECIFIED DIMENSIONS ARE IN INCHES. TOLERANCES ON: DECIMALS ±.015 ANGLES ±	CONTRACT NO	AMP INCORPORATED Harrisburg, Pa.	
	DR M. FEHER 2-19-80		
MATERIAL NYLON 94V-0	CHK D.S. Heide 2/29/80	STRAIN RELIEF FOR UNIVERSAL MATE-N-LOK HOUSING	
	APPD J.C. Fisher 2-29-80	APPD	
	DSGN APPD	SIZE C	CODE IDENT NO 00779
	OTHER APPD	DRAWING NO 350811	
		SCALE 2-1	SHEET