

Verpackt in Gurtverpackung
Verpackungseinheit: 560 Stück

- Tape on Reel Packaging
- Packaging unit: 560 pcs

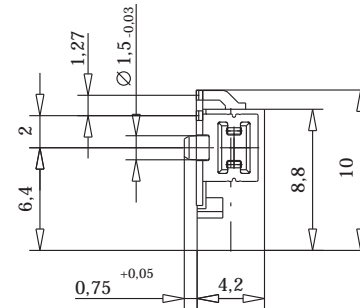

Abspulrichtung - Reel off Direction

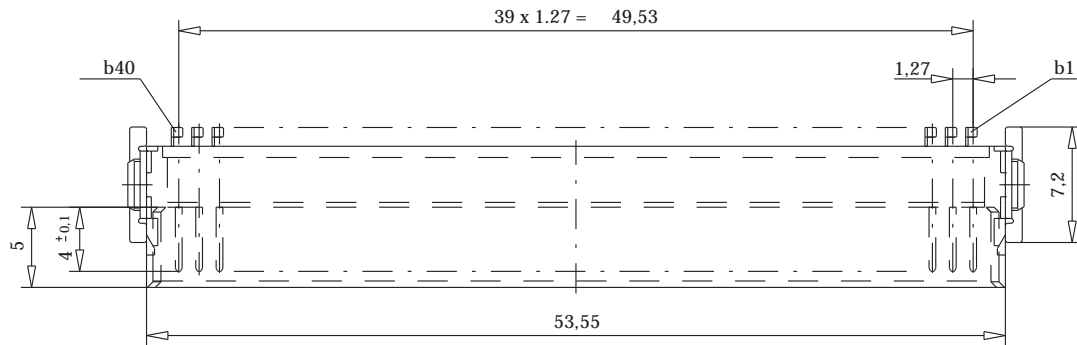
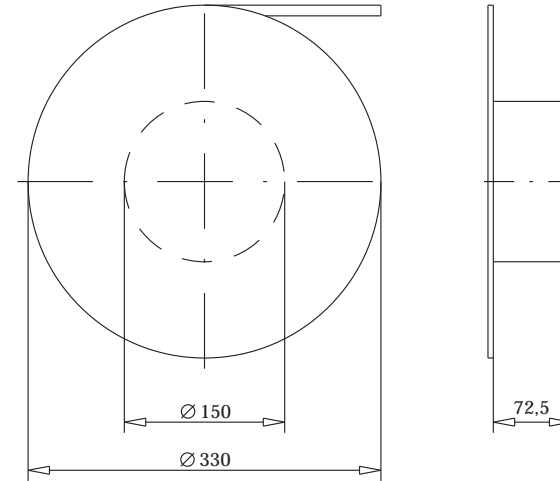
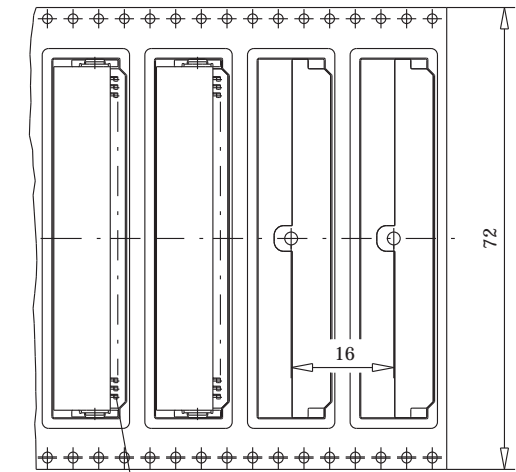

Leiterplatten-Layout Vorschlag für SMT
PCB-Layout Proposal for SMT

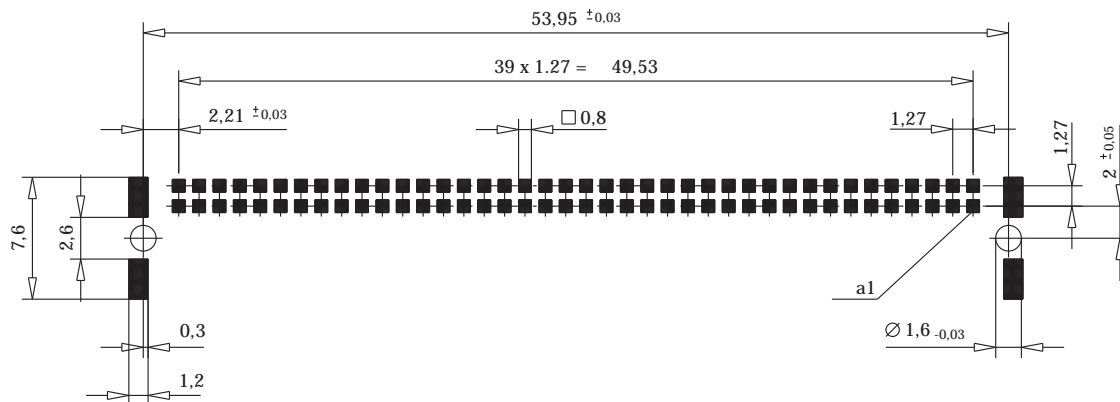

Anforderungsstufe 1
Performance Level 1

Kontaktbereich vergoldet
Mating Area gold plating

Anschlussbereich verzinkt 4-6 µm
Terminal Area 4-6 µm tin plating

Koplanarität der Anschlüsse ≤ 0.1mm
Coplanarity Area of Termination ≤ 0.1 mm

BA7-03 - Standard Bauhöhe

type7-03 - Standard Assembly Height

Information:	Tolerances  All Dimensions in mm	Scale	3:1
		XXXXX Angaben zu entsprechender klen-Nr. siehe Fertigungsunterlagen For further information about LD. number see manufacturing document.	
All rights reserved. Only for information. To insure that this is the latest version of this drawing, please contact one of the ERNI companies before using.	Subject to modification without prior notice. Drawing will not be updated.	Designation	
		Messerl. SMC-B 80-SMD-BA7-03 Male SMC-B 80-SMD-type7-03	
Index	Date	www.ERNI.com	
		154767	
V:00039958.SZN		SMCB	

Consider protection memo from DIN 34