



### Main

Range of product	Modicon TM3
Product or component type	Discrete input module
Range compatibility	Modicon M221 Modicon M241 Modicon M251
Discrete input number	8 input conforming to IEC 61131-2 Type 1
Discrete input voltage	120 V
Discrete input current	7.5 mA for input

### Complementary

Discrete I/O number	8
Current consumption	0 mA at 24 V DC via bus connector at state on 0 mA at 24 V DC via bus connector at state off 70 mA at 5 V DC via bus connector at state on 25 mA at 5 V DC via bus connector at state off
Discrete input voltage type	AC
Voltage state1 guaranteed	79...132 V for input
Current state 1 guaranteed	2...15 mA for input
Voltage state 0 guaranteed	0...20 V for input
Current state 0 guaranteed	0...15 mA for input
Input impedance	11 kOhm
Response time	25 ms for turn-on 30 ms for turn-off
Local signalling	Green for input status
Electrical connection	Removable screw terminal block pitch 5.08 mm with 11 terminal(s) of 2.5 mm <sup>2</sup> connection capacity for inputs
Insulation	Non-insulated between inputs 1500 V AC between input and internal logic 1500 V AC between input groups
Marking	CE
Mounting support	Top hat type TH35-15 rail conforming to IEC 60715 Top hat type TH35-7.5 rail conforming to IEC 60715 Plate or panel with fixing kit
Height	90 mm
Depth	84.6 mm
Width	27.4 mm

### Environment

standards	EN/IEC 61131-2 EN/IEC 61010-2-201
product certifications	C-Tick CULus
resistance to electrostatic discharge	4 kV (on contact) conforming to EN/IEC 61000-4-2 8 kV (in air) conforming to EN/IEC 61000-4-2
resistance to electromagnetic fields	10 V/m at 80 MHz...1 GHz conforming to EN/IEC 61000-4-3 3 V/m at 1.4 GHz...2 GHz conforming to EN/IEC 61000-4-3 1 V/m at 2 GHz...3 GHz conforming to EN/IEC 61000-4-3
resistance to magnetic fields	30 A/m at 50...60 Hz conforming to EN/IEC 61000-4-8
resistance to fast transients	1 kV for I/O conforming to EN/IEC 61000-4-4
surge withstand	2 kV for I/O (AC) in common mode conforming to EN/IEC 61000-4-5

The information provided in this documentation contains general descriptions and/or technical characteristics of the products contained herein. This documentation is not intended as a substitute for and is not to be used for determining suitability or reliability of these products for specific user applications. It is the duty of any such user or integrator to perform the appropriate and complete risk analysis, evaluation and testing of the products with respect to the relevant specific application or use thereof. Neither Schneider Electric Industries SAS nor any of its affiliates or subsidiaries shall be responsible or liable for misuse of the information contained herein.

resistance to conducted disturbances, induced by radio frequency fields	10 Vrms at 0.15...80 MHz conforming to EN/IEC 61000-4-6 3 Vrms at spot frequency (2, 3, 4, 6.2, 8.2, 12.6, 16.5, 18.8, 22, 25 MHz) conforming to Marine specification (LR, ABS, DNV, GL)
electromagnetic emission	Radiated emissions, test level: 40 dB $\mu$ V/m QP with class A, condition of test: 10 m (radio frequency: 30...230 MHz) conforming to EN/IEC 55011 Radiated emissions, test level: 47 dB $\mu$ V/m QP with class A, condition of test: 10 m (radio frequency: 230 MHz...1 GHz) conforming to EN/IEC 55011
ambient air temperature for operation	-10...55 °C for horizontal installation -10...35 °C for vertical installation
ambient air temperature for storage	-25...70 °C
relative humidity	10...95 % without condensation in operation 10...95 % without condensation in storage
IP degree of protection	IP20 with protective cover in place
pollution degree	2
operating altitude	0...2000 m
storage altitude	0...3000 m
vibration resistance	3.5 mm (vibration frequency: 5...8.4 Hz) on DIN rail 3 gn (vibration frequency: 8.4...150 Hz) on DIN rail 3.5 mm (vibration frequency: 5...8.4 Hz) on panel 3 gn (vibration frequency: 8.4...150 Hz) on panel
shock resistance	15 gn (test wave duration: 11 ms)

## Offer Sustainability

Sustainable offer status	Green Premium product
RoHS (date code: YYWW)	Compliant - since 1348 - Schneider Electric declaration of conformity
REACH	Reference not containing SVHC above the threshold
Product environmental profile	Available
Product end of life instructions	Available

## Dimensions

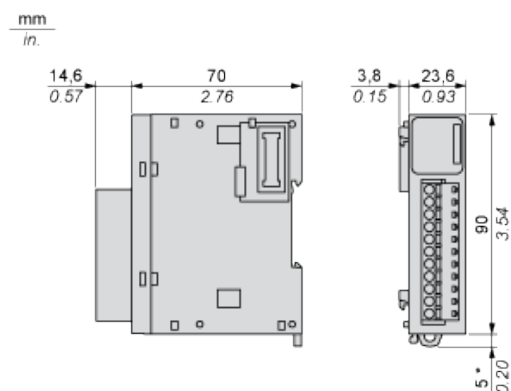

(\*) 8.5 mm/0.33 in. when the clamp is pulled out.

## Spacing Requirements

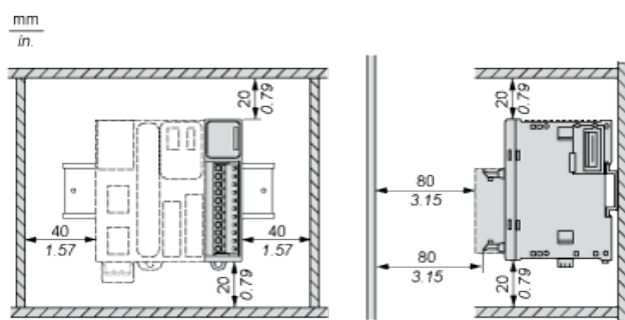

## Mounting on a Rail

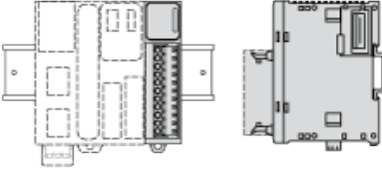

## Incorrect Mounting

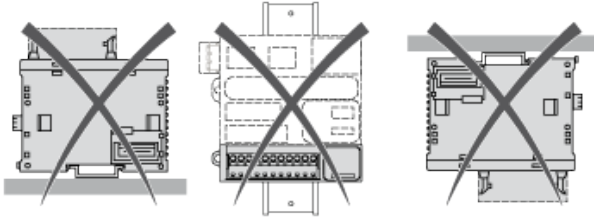

## Mounting on a Panel Surface

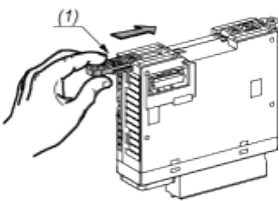

(1) Install a mounting strip

## Mounting Hole Layout

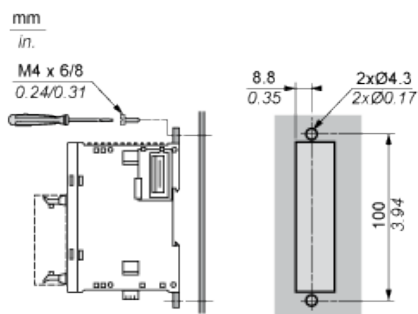

## Digital Input Module (8-channel, 120 Vac)

### Wiring Diagram

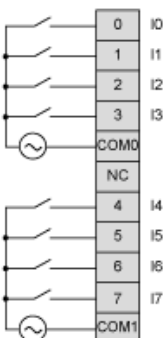

The COM0 and COM1 terminal are **not** connected internally.