

THIS DRAWING IS UNPUBLISHED. RELEASED FOR PUBLICATION
 © COPYRIGHT - By - ALL RIGHTS RESERVED.

LOC		DIST		REVISIONS			
P	LTR	DESCRIPTION		DATE	DWN	APVD	
CM	00	AA3	REVISED PER ECR-11-006429	12APR11	HMR	TM	

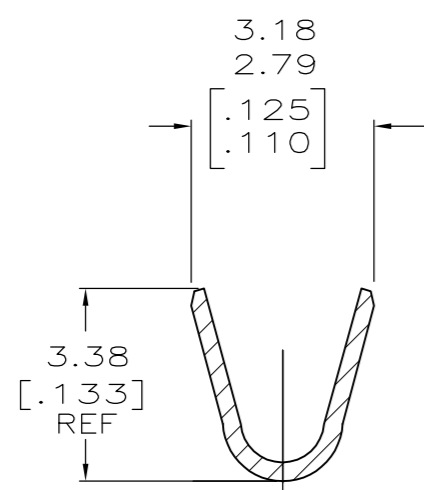

SECTION A-A
SCALE 10:1

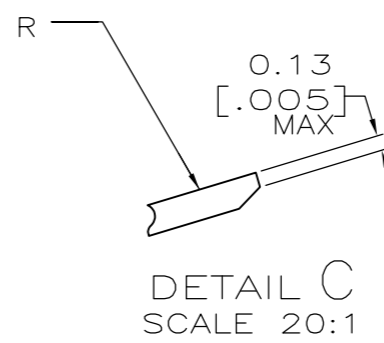
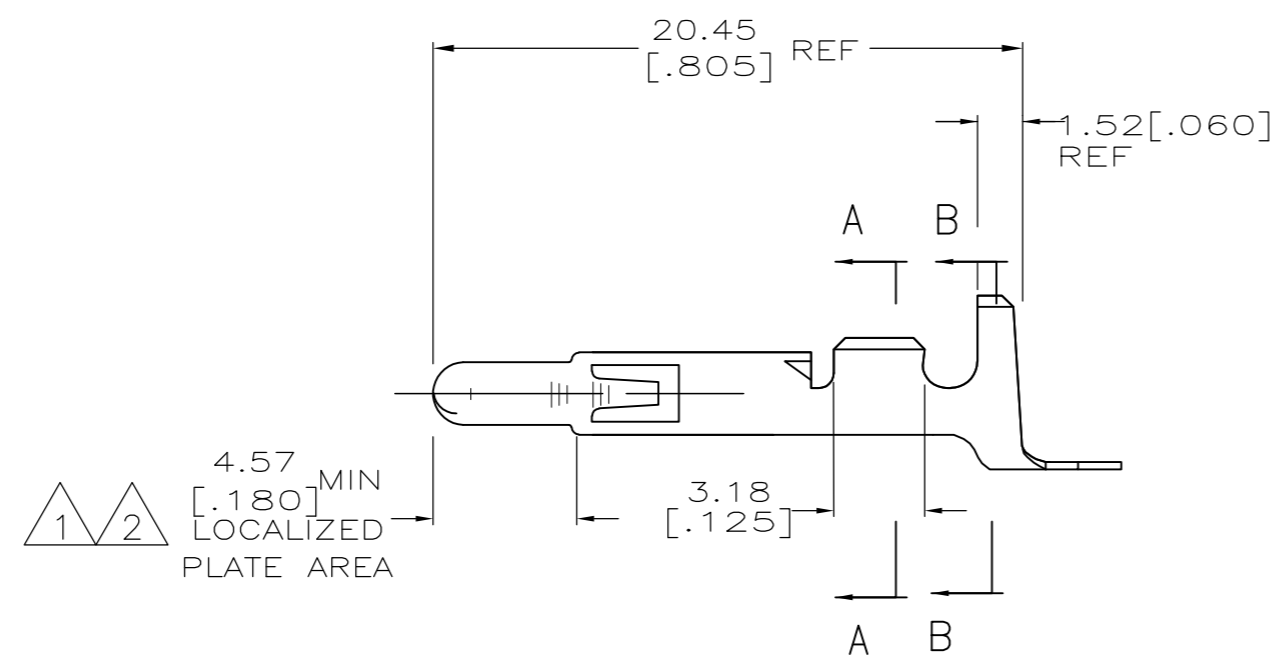
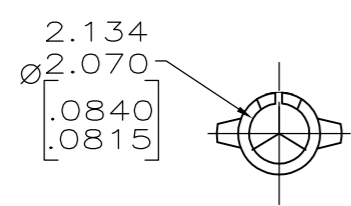
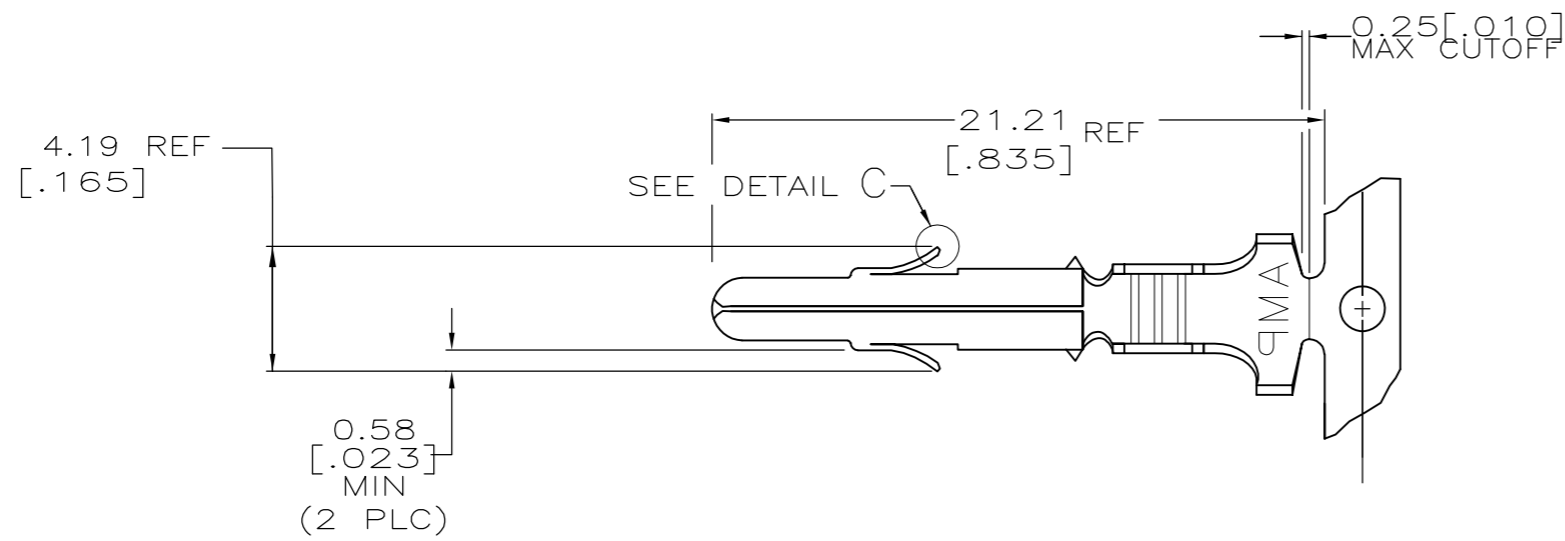
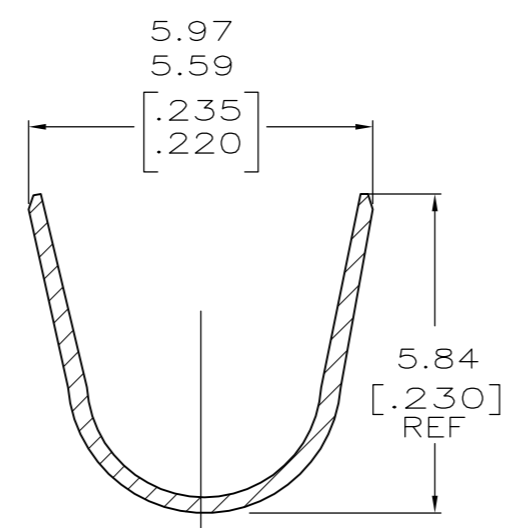

SECTION B-B
SCALE 10:1

- 1 0.00076[.000030] MIN THK GOLD IN LOCALIZED PLATE AREA AND 0.000127[.000005] MIN THK GOLD FLASH ON REMAINDER OF CONTACT OVER 0.00127[.000050] MIN THK NICKEL UNDERPLATE.
- 2 0.00076[.000030] MIN THK GOLD IN LOCALIZED PLATE AREA OVER 0.00127[.000050] MIN THK NICKEL UNDERPLATE.
- 3 DIMENSIONS IN BRACKETS ARE IN INCHES.

350552-7	GOLD	2	0.30 [.012]	BRASS	350538-7
350552-6	GOLD	2	0.30 [.012]	PH BZ	350538-6
350552-3	TIN		0.30 [.012]	PH BZ	350538-3
350552-2	GOLD	1	0.30 [.012]	BRASS	350538-2
350552-1	TIN		0.30 [.012]	BRASS	350538-1
LOOSE PIECE (REF)	FINISH		MATERIAL	PART NO	

THIS DRAWING IS A CONTROLLED DOCUMENT.		DWN K. WHITAKER 16-FEB-04	TE Connectivity		
DIMENSIONS: mm [INCHES]		CHK S. RIDGILL 16-FEB-04			
TOLERANCES UNLESS OTHERWISE SPECIFIED:		APVD S. RIDGILL 16-FEB-04	NAME PIN, UNIVERSAL MATE-N-LOK™		
0 PLC ± - 1 PLC ± - 2 PLC ± - 3 PLC ± 0.20.008 4 PLC ± - ANGLES ± -		PRODUCT SPEC	SIZE A2		
MATERIAL SEE TABLE		APPLICATION SPEC	CAGE CODE 00779	DRAWING NO C=350538	RESTRICTED TO
FINISH SEE TABLE		WEIGHT -	SCALE 4:1	SHEET 1 OF 1	REV AA3
CUSTOMER DRAWING					