



# har-bus® HM female connector



## General information

Design	IEC 61076-4-101	
No. of contacts	55 - 220 signal (77 - 308 fully shielded); or customised	
Contact spacing	2,0mm	
Test voltage	750V AC	
Contact resistance	max. 20mOhm	
Insulation resistance	min. 10 <sup>10</sup> Ohm	
Working current	1A at 70°C	(see derating diagram)
Temperature range	-55°C ... +125°C	
Termination technology	press-in	
Clearance & creepage distance	0,6 mm each for free connector	
Insertion and withdrawal force	insertion force per contact:	0,75N max.
	withdrawal force per contact:	0,15N min.
Mating cycles	- PL1 acc. to IEC 61076-4-101 =>	500 mating cycles
	- PL2 acc. to IEC 61076-4-101 =>	250 mating cycles
UL file	E102079	
RoHS - compliant	Yes	
Leadfree	Yes	

## Insulator material

Material	PBT (thermoplastics, glass fiber reinforcement 30%)	
Colour	RAL 7032 (grey)	
UL classification	UL 94-V0	
Material group acc. to IEC 60664-1	IIIa (175 ≤ CTI < 400)	
NFF classification	I3, F4	

## Contact material

Contact material	Copper alloy	
Treatment contact zone	Bellcore recommended lubricant (PPE)	
Plating press-in zone	Ni	
Plating contact zone	- PL 1 / PL 2	Au over Ni
	- "S4" acc. to HARTING internal PL =>	0,8µm Au over 2,0µm Ni

## Derating diagram acc. to IEC 60512-5 (Current carrying capacity)

The current carrying capacity is limited by maximum temperature of materials for inserts and contacts including terminals.  
The current capacity curve is valid for continuous, non interrupted current loaded contacts of connectors when simultaneous power on all contacts is given, without exceeding the maximum temperature.

Control and test procedures according to DIN IEC 60512-5

Curve 1 shows raise in temperature  
Curve 2 shows nominal derating Date Name  
Curve 3 shows reduced values as per IEC512

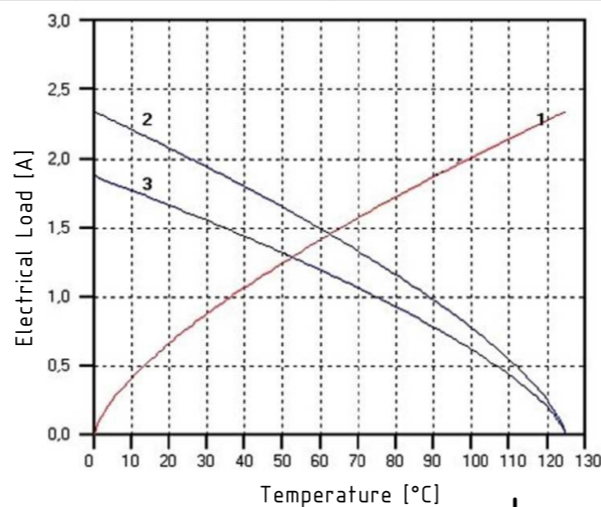

## Recommended configuration of plated through holes for press-in termination

In addition to the hot-air-level (HAL), other PCB surfaces are getting more important. Due to their different properties - such as mechanical strength and coefficient of friction - we recommend the following configuration of PCB through holes.

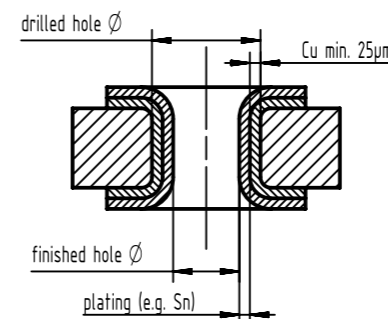

PCB Type	Plating	Drilled hole Ø	Plated hole Ø
Tin plated PCB (HAL) acc. to EN 60352-5	Sn	0,7±0,02 mm	max. 15 µm
			0,60 - 0,65 mm
Chemical tin plated PCB	Sn	0,7±0,02 mm	min. 0,8µm
			0,60 - 0,65 mm
Gold /Nickel plated PCB	Ni	0,7±0,02 mm	3 - 7 µm
	Au		0,05 - 0,12 µm
			0,60 - 0,65 mm
Silver plated PCB	Ag	0,7±0,02 mm	0,1 - 0,3 µm
			0,60 - 0,65 mm
Copper plated PCB (OSP)		0,7±0,02 mm	
			0,60 - 0,65 mm

## Assembly instructions

It is highly recommended to use HARTING press-in tools to ensure a reliable press-in process. Please refer to the catalogue for tools, machines and further information about the press-in process.

## Circuit density

When using the specified diameter of the finished through hole according to IEC 61 076-4-101 (0.6 ± 0.05mm) with an appropriate annular ring, the remaining distance between the rings is about 1mm.

Under the condition that the width of the track and the space between should be equal, two tracks of 0.2mm width or three tracks of 0.14mm width can be placed between two rings.

Typical designs are shown in the drawing on the right side.

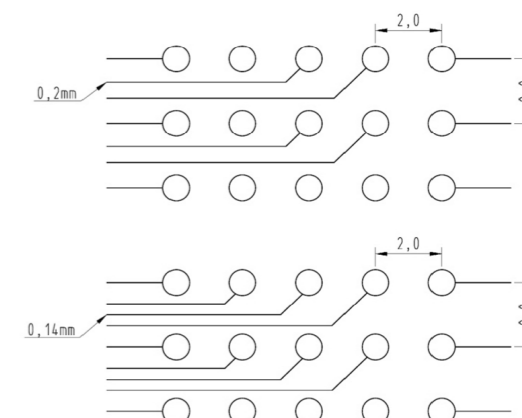

		All Dimensions in mm Original Size DIN A3	Scale 1:1	Free size tol.	Ref. Sub. DS 17 00 220 0101 / ECM1567 / 22.05.2012	
		All rights reserved Department EC PD - DE	Created by TADJE	Inspected by DAHMS	Standardisation HOFFMANN	Date 2016-06-28
HARTING Electronics GmbH D-32339 Espelkamp		Title har-bus® HM female connector			Doc-Key / ECM-Nr. 100580923/UGD/000/A 500000105974	
		Type DS	Number 17002200101		Rev. A	Page 1/1