

## Solid-state Multi-functional Timer

## H3DE-M/-S

- Eight operating modes (H3DE-M) and four operating modes (H3DE-S) cover a wide range of applications.
- Programmable contact enables the building of a self-holding relay circuit (-□2 models).
- A wide time setting range of 0.10 s to 120 h.

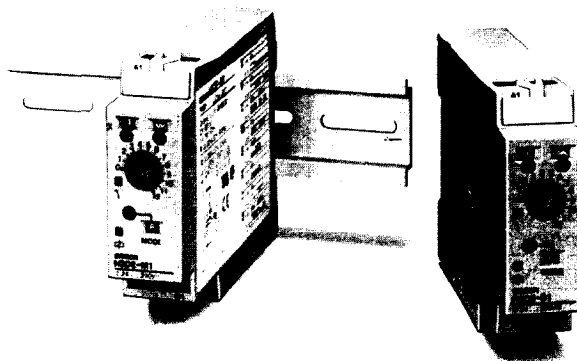

## Ordering Information

Supply voltage	Control output	Model	
		Multi-function type	Standard type
24 to 230 VAC/DC	Contact output: DPDT (time-limit output SPDT and switchable SPDT (time-limit ←→ instantaneous))	H3DE-M2	H3DE-S2
	Contact output: SPDT (time-limit output SPDT)	H3DE-M1	H3DE-S1

### Model Number Legend

H3DE -    
           1    2

1. M: Multi-function type  
S: Standard type
2. 2: DPDT  
1: SPDT

### Accessories (Order Separately)

Mounting Track	50 cm (l) x 7.3 mm (t)	PFP-50N
	1 m (l) x 7.3 mm (t)	PFP-100N
	1 m (l) x 16 mm (t)	PFP-100N2
End Plate	PFP-M	
Spacer	PFP-S	

# Specifications

## ■ General

Item	H3DE-M2	H3DE-M1	H3DE-S2	H3DE-S1
Operating mode	A: ON-delay (Signal or Power) B: Flicker OFF start (Signal or Power) B2: Flicker ON start (Signal or Power) C: Signal ON/OFF-delay D: Signal OFF-delay E: Interval (Signal or Power) G: Signal ON/OFF-delay J: One-shot (Signal or Power)		A: ON-delay B2: Flicker ON start E: Interval J: One-shot	
Terminal block	Clamps two 2.5 mm <sup>2</sup> max. bar terminals without sleeves.			
Terminal screw tightening torque	10 kgf max.			
Input type	Voltage input		---	
Output type	Relay: DPDT	Relay: SPDT	Relay: DPDT	Relay: SPDT
Mounting method	DIN track mounting			
Attachment	Nameplate			
Approved standards	UL508, CSA 22.2 No.14 Conforms to EN61812-1 (VDE0435/P2021), IEC60664-1 (VDE0110) 4 kV/2, VDE0106/P100 Conforms to IEC60947-5-1 (AC-13; 250 V 5A/AC-15; 250 V 3 A/DC-13; 30 V 0.1 A) Conforms to EN50081-1 and EN50082-2			

## ■ Time Ranges

Time scale display	Time unit display			
	sec	min	hrs	10 h
x 0.1	0.1 to 1.2 s	0.1 to 1.2 min	0.1 to 1.2 h	1 to 12 h
x 1	1 to 12 s	1 to 12 min	1 to 12 h	10 to 120 h

Note: When the main dial is set to "0" for all settings, the output will operate instantaneously.

## ■ Ratings

Rated supply voltage (see notes 1 and 2)	24 to 230 VAC/DC (50/60 Hz)	
Operating voltage range	85% to 110% of rated supply voltage	
Power reset	Minimum power-off time: 0.1 s	
Reset voltage	2.4 VAC/DC max.	
Power consumption (see note 3)	H3DE-M1	AC: approx. 2.8 VA (1.8 W) at 230 VAC DC: approx. 0.7 W at 24 VDC
	H3DE-M2	AC: approx. 3.3 VA (2.1 W) at 230 VAC DC: approx. 1.0 W at 24 VDC
	H3DE-S1	AC: approx. 2.7 VA (1.6 W) at 230 VAC DC: approx. 0.7 W at 24 VDC
	H3DE-S2	AC: approx. 3.2 VA (1.9 W) at 230 VAC DC: approx. 1.0 W at 24 VDC
Voltage input	H-level: 20.4 to 253 VAC/DC L-level: 0 to 2.4 VAC/DC	
Control output	Contact output: 5 A at 250 VAC with resistive load ( $\cos\phi = 1$ ) 5 A at 30 VDC with resistive load ( $\cos\phi = 1$ )	
Ambient temperature	Operating: -10°C to 55°C (with no icing) Storage: -25°C to 65°C (with no icing)	
Ambient humidity	Operating: 35% to 85%	

Note: 1. DC ripple rate: 20% max.

2. Since an inrush current of 0.25 A will occur when using the power supply voltage at 24 VDC, pay careful attention when turning on or off the power supply to the Timer with a solid-state output such as a sensor.

3. The power consumption is for mode A after the Timer counts the time-up time and for the AC input at 50 Hz. The power consumption of the H3DE-M□ includes the input circuit with the B1 and A1 terminals short-circuited.

## ■ Characteristics

<b>Accuracy of operating time</b>	±1% max. of FS (±1% ±10 ms max. at 1.2-s range)
<b>Setting error</b>	±10% ±0.05 s max. of FS
<b>Signal input time</b>	50 ms min.
<b>Influence of voltage</b>	±0.5% max. of FS (±0.5% ±10 ms max. at 1.2-s range)
<b>Influence of temperature</b>	±2% max. of FS (±2% ±10 ms max. at 1.2-s range)
<b>Insulation resistance</b>	100 MΩ min. at 500 VDC
<b>Dielectric strength</b>	Between current-carrying metal parts and exposed non-current-carrying metal parts: 2,000 VAC for 1 min. Between control output terminals and operating circuit: 2,000 VAC for 1 min. Between contacts not located next to each other: 1,000 VAC for 1 min.
<b>Vibration resistance</b>	Malfunction: 0.5-mm single amplitude at 10 to 55 Hz Destruction: 0.75-mm single amplitude at 10 to 55 Hz
<b>Shock resistance</b>	Malfunction: 100 m/s <sup>2</sup> (approximately 10G) Destruction: 1,000 m/s <sup>2</sup> (approximately 100G)
<b>Contact material</b>	AGNi+gold plating (Use the G6RN-1 at 12 VDC.)
<b>Impulse withstand voltage</b>	3 kV (between power terminals) 4.5 kV (between current-carrying metal parts and exposed non-current-carrying metal parts)
<b>Noise immunity</b>	Square-wave noise generated by noise simulator (pulse width: 100 ns/1 μs, 1-ns rise) ±1.5 kV
<b>Static immunity</b>	Malfunction: 4 kV Destruction: 8 kV
<b>Life expectancy</b>	Mechanical: 10 million operations min. (under no load at 1,800 operations/h) Electrical: 100,000 operations min. (5 A at 250 VAC, resistive load at 360 operations/h) (see note)
<b>EMC</b>	(EMI): EN50081-1 Emission Enclosure: EN55022 class B Emission AC Mains: EN55022 class B Harmonic Current: EN61000-3-2 Voltage Fluctuation and Flickering: EN61000-3-3 (EMS): EN50082-2 Immunity ESD: EN61000-4-2: 4 kV contact discharge (level 2) 8 kV air discharge (level 3) Immunity RF-interference from AM Radio Waves: ENV50140: 10 V/m (80 MHz to 1 GHz) (level 3) Immunity RF-interference from Pulse-modulated Radio Waves: ENV50204: 10 V/m (900 ±5 MHz) (level 3) Immunity Conducted Disturbance: ENV50141: 10 V (0.15 to 80 MHz) (level 3) Immunity Burst: EN61000-4-4: 2 kV power line (level 3) 2 kV I/O signal line (level 4)
<b>Enclosure rating</b>	IP30 (Terminal block: IP20)
<b>Weight</b>	120 g

**Note:** For reference:

A maximum current of 0.15 A can be switched at 125 VDC (cosφ=1).

A maximum current of 0.1 A can be switched if L/R is 7 ms.

In both cases, a life of 100,000 operations can be expected.

The minimum applicable load is 10 mA at 5 VDC (failure level: P).

# Nomenclature

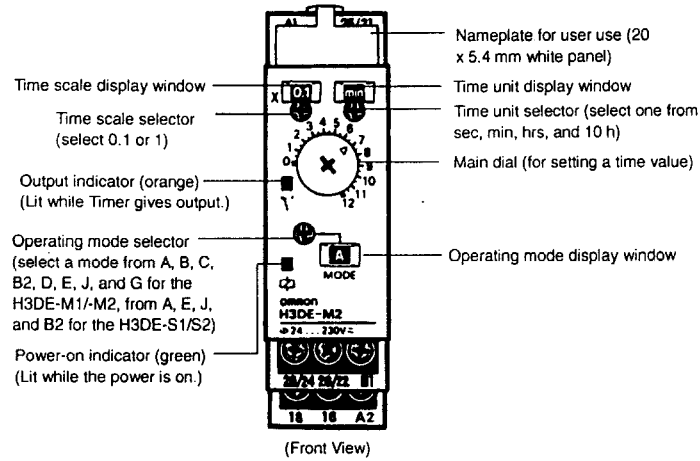

Output Type Selector Switch Settings

Setting	Output type
	Time-limit output (terminal numbers 25, 26 and 28) (default setting)
	Instantaneous output (terminal numbers 21, 22 and 24)

# Operation

## Block Diagram

H3DE-M1/-M2

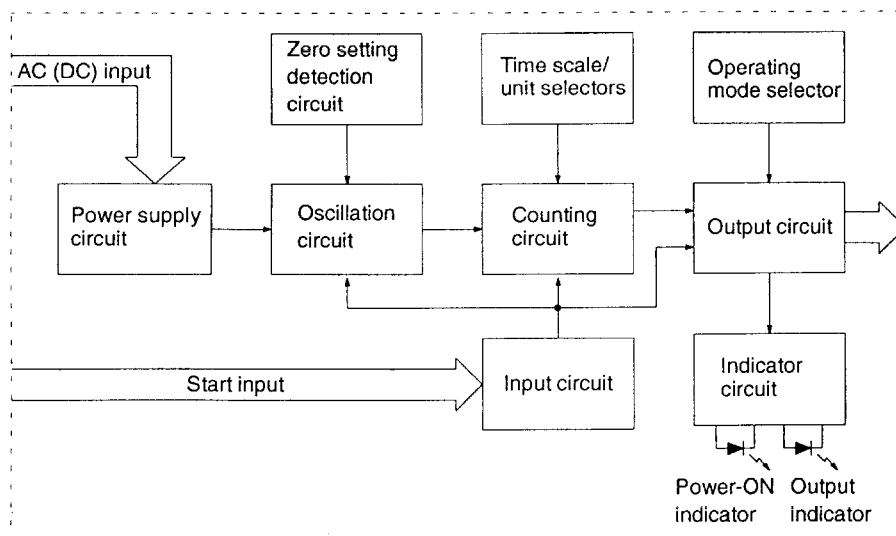

H3DE-S1/-S2

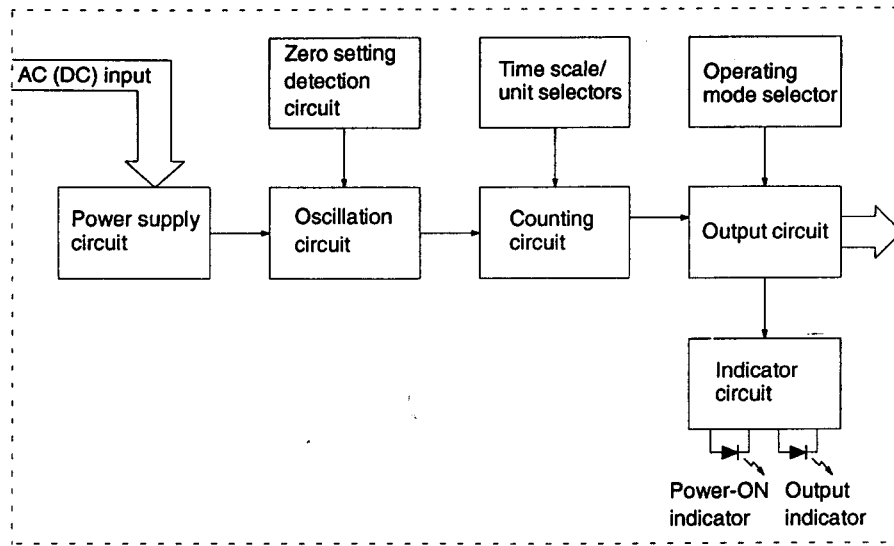

■ I/O Functions

Item		H3DE-M1/-M2	H3DE-S1/-S2
Input	Start	Starts operation.	No input is available.
Output	Control output	Outputs are turned ON according to designated output mode when preset value is reached. (See note.)	Outputs are turned ON according to designated output mode when preset value is reached. (see note.)

**Note:** When the output type selector switch on the bottom of the Timer is set to the instantaneous side, the relay R2 (terminal numbers 21/25, 22/26, and 24/28) becomes an instantaneous contact and turns ON/OFF in synchronization with the changes in the power supply.

■ Basic Operation

Setting of Selector

The selectors can be turned clockwise and counterclockwise to select the desired time unit, time scale, or operating mode.

Each selector has a snap mechanism that secures the selector at a given position. Set the selector at a position at which it is secured. Do not set it midway between two securing positions or a malfunction could result from improper setting.

Selection of Time Unit and Time Scale

The desired time unit (s, m, h, or 10h) can be displayed in the time unit display window above the time setting dial by turning the time unit selector located at the upper right corner of the front panel. Time scale (0.1 or 1) is selected with the time scale selector at the upper left corner of the front panel, it appears in the time scale display window above the selector.

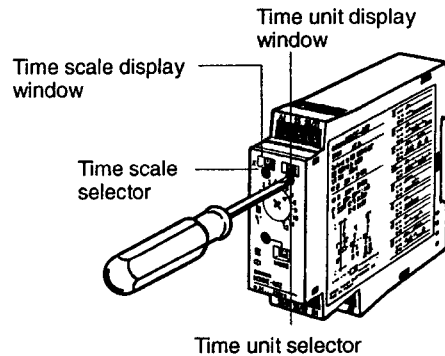
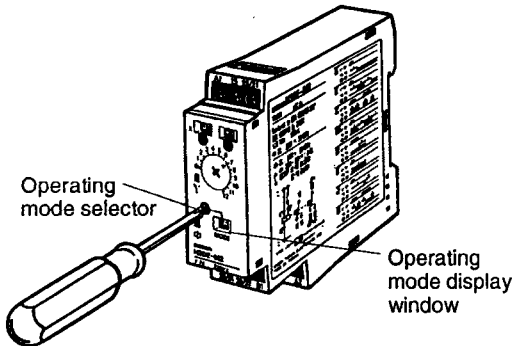

Selection of Operating Mode

The H3DE-M/-S can be set to any one of the operating modes A to J. Turn the operating mode selector with a screwdriver until the desired operating mode (A, B, C, B2, D, E, J, or G for the H3DE-M and A, E, J, or B2 for the H3DE-S) appears in the operating mode display window located below the selector.

■ Timing Chart

- Note:** 1. The minimum power reset time is 0.1 s and the minimum signal input time is 0.05 s.  
 2. The letter "t" in the timing charts stands for the set time and "t-a" means that the period is less than the time set.

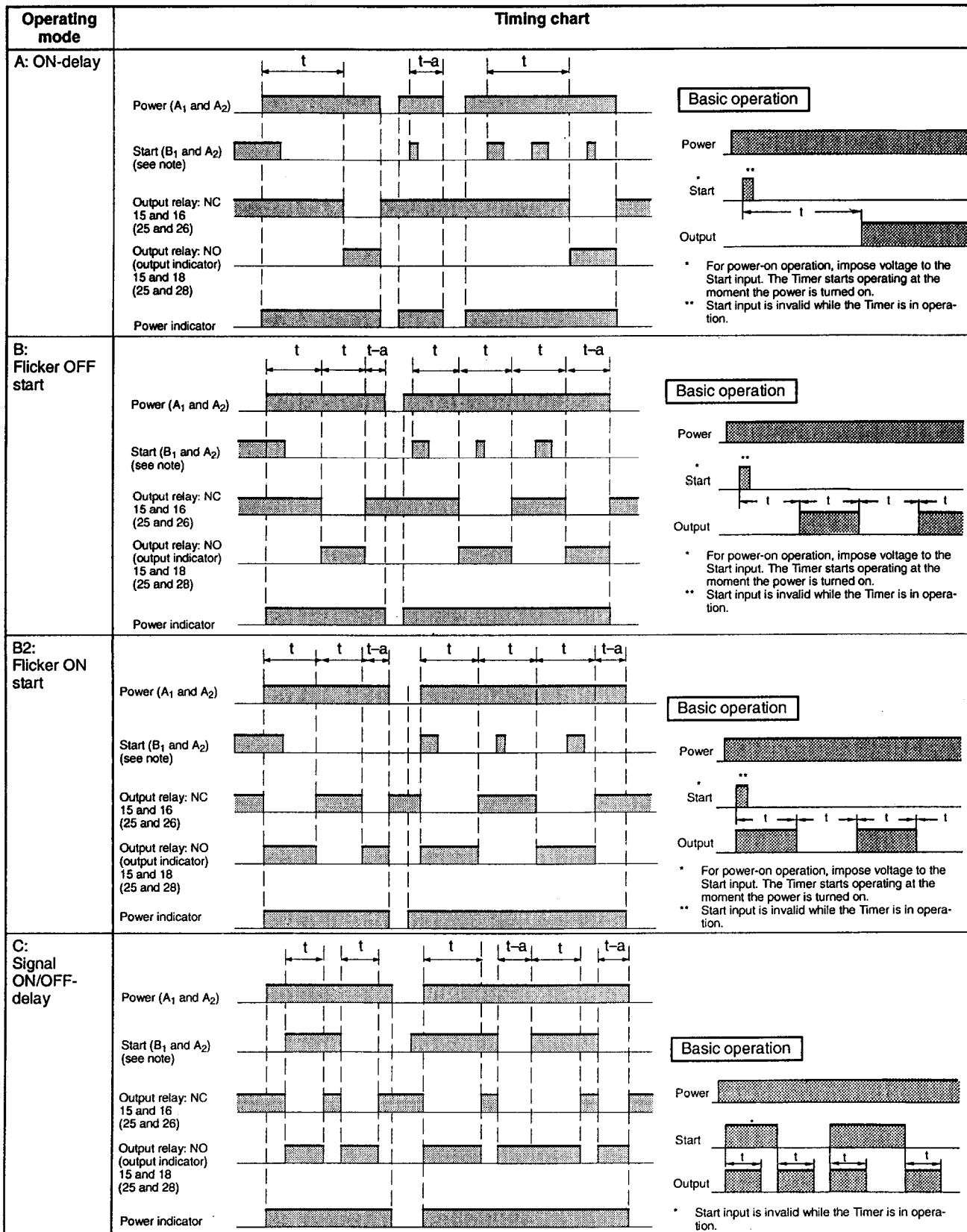

**Note:** The start input of the H3DE-M1 or H3DE-M2 model is activated by applying a voltage to B1 and A2 terminals. The voltage can be applied by turning on the contact between B1 and A1 (Refer to *Terminal Arrangement*).

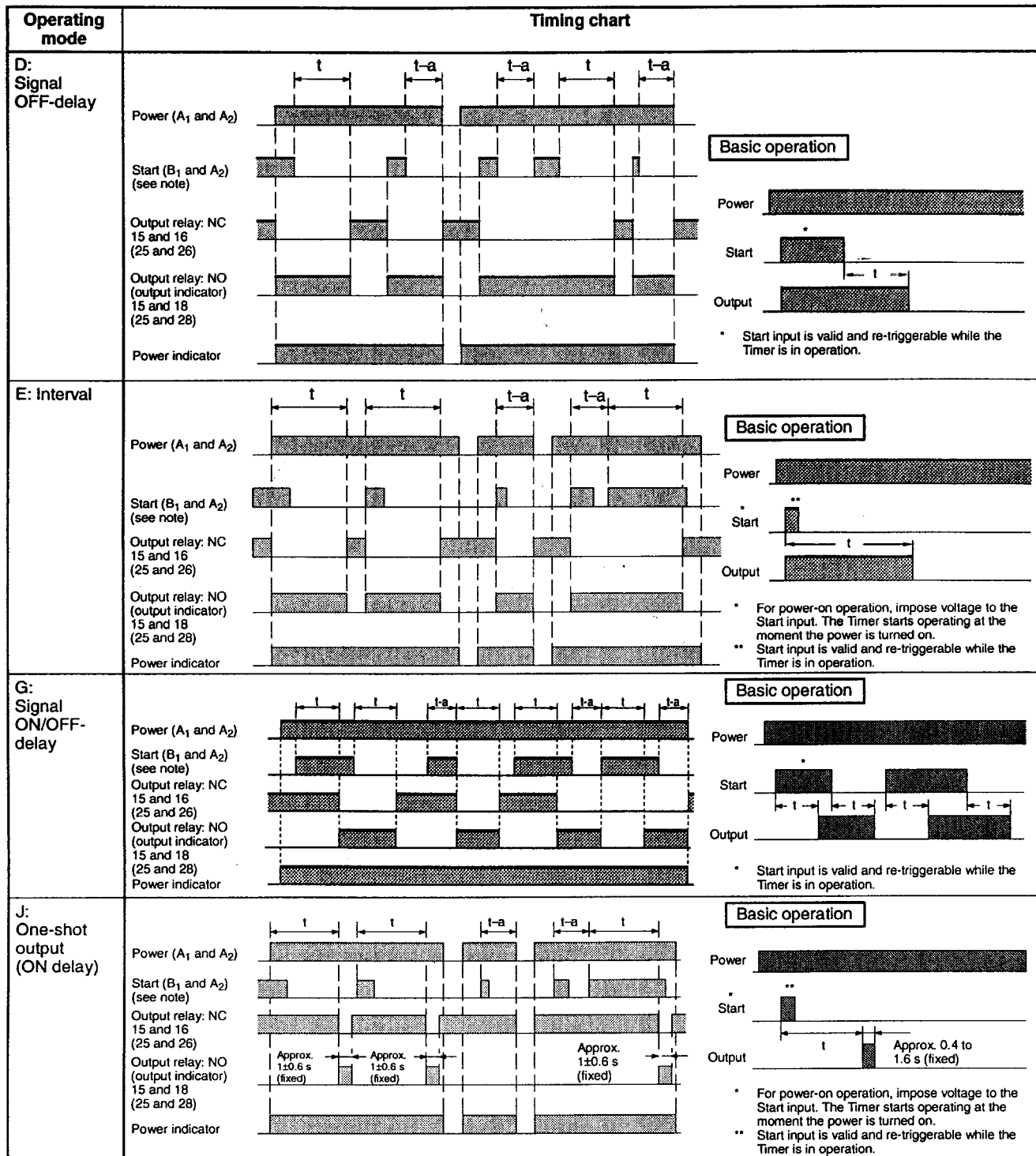

**Note:** The start input of the H3DE-M1 or H3DE-M2 model is activated by applying a voltage to B1 and A2 terminals. The voltage can be applied by turning on the contact between B1 and A1 (Refer to *Terminal Arrangement*).

**ALL DIMENSIONS SHOWN ARE IN MILLIMETERS.**

To convert millimeters into inches, multiply by 0.03937. To convert grams into ounces, multiply by 0.03527.

Cat. No. L92-E1-3 In the interest of product improvement, specifications are subject to change without notice.

**OMRON Corporation**

Supervisory Control Devices Division

28th Fl., Crystal Tower Bldg.

1-2-27, Shiromi, Chuo-ku,

Osaka 540-6028 Japan

Phone: (81)6-949-6035 Fax: (81)6-949-6069

Printed in Japan

0398-3M Ⓐ



## ■ Precautions for VDE Conformance

The H3DE as a built-in timer conforms to VDE 0435/P2021 provided that the following conditions are satisfied:

The output section of the H3DE is provided only with basic isolation. To ensure reinforced isolation required by the VDE standards, provide supplementary basic isolation on the load side connected to the output.

The H3DE itself is designed according to the following:

- Overvoltage category III
- Pollution degree 2

On the above basis:

Operation parts on the front and bottom: Reinforced isolation

- With clearance of 5.5 mm and creepage distance of 5.5 mm at 230 VAC

Output: Basic isolation

- With clearance of 3 mm and creepage distance of 3 mm at 230 VAC

## ■ Environment

When using the Timer in an area with excess electronic noise, separate the Timer, wiring, and the equipment which generates the input signals as far as possible from the noise sources. It is also recommended to shield the input signal wiring to prevent electronic interference.

Organic solvents (such as paint thinner), as well as very acidic or basic solutions can damage the outer casing of the Timer.

Do not use the Timer in places where it is exposed to dust, corrosive gas, or direct sunlight.

When storing the Timer, make sure that the ambient temperature and humidity are within the rated values. Leave the Timer at room temperature for at least three hours before using the Timer if it has been stored at an ambient temperature of  $-10^{\circ}\text{C}$  or below.

## ■ Others

If the Timer is mounted on a control board, dismount the Timer from the control board or short-circuit the circuitry of the power board before carrying out a voltage withstand test between the electric circuitry and non current-carrying metal part of the Timer, in order to prevent the internal circuitry of the Timer from damage.

It must be noted that although the electrical life expectancy of the H3DE Timer shown in the catalog is the same as the H3DR Timer shown in the catalog, the actual performance varies because the built-in relays are different as follows:

Built-in relay for the H3DR: G2R; 100,000 operations min.  
(10 A for SPDT and 5 A for DPDT at 250 VAC, resistive load at 1,800 operations/h.)

Built-in relay for the H3DE: G6RN; 50,000 operations min.  
(8 A at 250 VAC, resistive load at 360 operations/h.)

**Switching Current vs. Ambient Temperature  
(When Mounting Two or More H3DE Units Side-by-Side)**

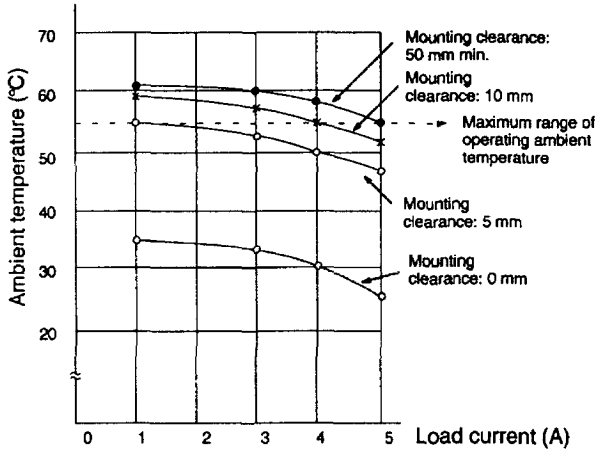

(Measurement Condition: Input voltage of 230 VAC)

**Input/Output**

**Relationship between Input and Power Supply Circuits**

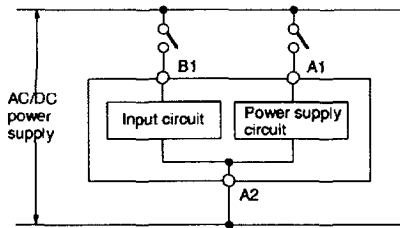

Since the input circuit and the power supply circuit are configured independently, the input circuit can be turned on or off irrespective of the on/off state of the power supply. It must be noted that a voltage equivalent to the power supply voltage is applied to the input circuit.

When connecting a relay or a transistor as an external signal input device, pay attention to the following points to prevent short-circuiting due to a sneak current to the transformerless power supply.

If a relay or transistor is connected to two or more Timers, the input terminals of those Timers must be wired properly so that they will not be different in phase or the terminals will be short-circuited to one another (refer to the figures below).

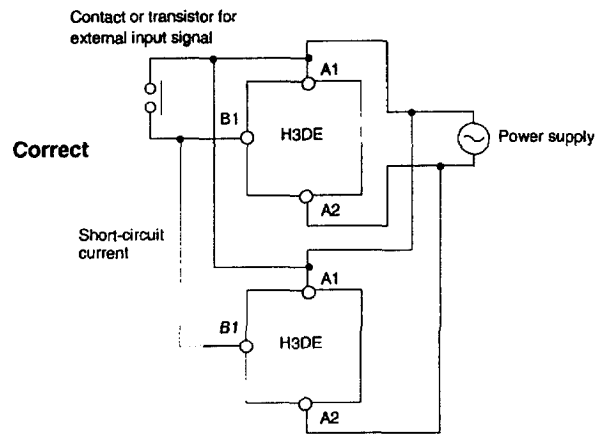
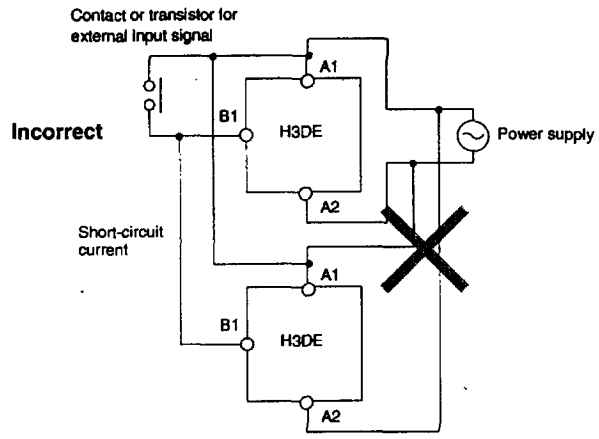

The H3DE Series is provided with a transformerless power supply system.

**Wiring (H3DE-H)**

The H3DE has a high impedance circuit. Therefore, the H3DE may not be reset if the H3DE is influenced by inductive voltage. In order to eliminate any influence of inductive voltage, the wires connected to the H3DE must be as short as possible and should not be installed alongside power lines. If the H3DE is influenced by inductive voltage that is 30% or more of the rated voltage, connect a CR filter with a capacitance of approximately 0.1 μF and a resistance of approximately 120 Ω or a bleeder resistor between the power supply terminals. If there is any residual voltage due to current leakage, connect a bleeder resistor between the power supply terminals.

**Operation (H3DE-H)**

An interval of 3 s minimum is required to turn on the H3DE after the H3DE is turned off. If the H3DE is turned on and off repeatedly with an interval of shorter than 3 s, the internal parts of the H3DE may deteriorate and the H3DE may malfunction.

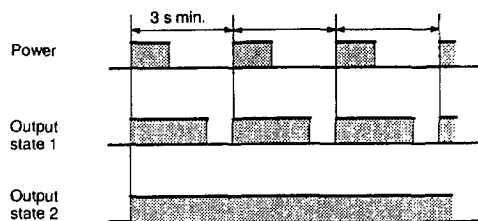

If it is required that the output be turned on repeatedly with an interval of shorter than 3 s, consider use of the H3DE-M2/-M1 in mode D (signal OFF-delay).

## Precautions

**Note:** The undermentioned is common for all H3DE models.

### ■ Changing of Setting

**NOTICE:** Do not change the time unit, time scale, operating mode, or output type selector switch while the Timer is in operation or malfunction could result.

### ■ Mounting and Dismounting

The H3DE should be mounted as horizontally as possible.

When mounting the H3DE on a socket mounting track, hook portion (A) of the Timer to an edge of the track first, and then depress the Timer in the direction of (B).

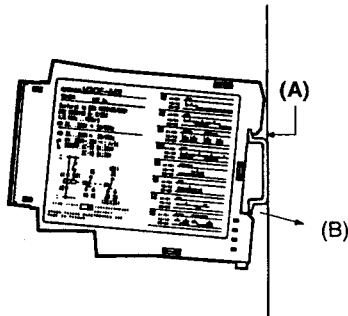

When dismantling the H3DE, pull out portion (C) with a flat-blade screwdriver and remove the Timer from the mounting track.

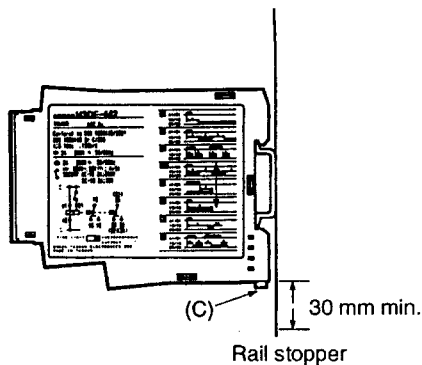

The H3DE can be mounted and dismantled with ease if a distance of 30 mm or more is kept between the H3DE and the top surface of other equipment located below the H3DE.

### ■ Power Supplies

The H3DE Series is provided with a transformerless power supply system. An electric shock may be received if the input terminal or the output type selector switch is touched while power is being supplied.

Use the bar terminal for wiring the H3DE. Using a stranded-wire terminal may cause a short-circuit due to a stray wire entering into the Timer.

Both AC and DC power supplies can be connected to the power input terminals without regarding polarity.

With the H3DE only, a DC power supply must be connected to the power input terminals as designated according to the polarity of the terminals.

A DC power supply can be connected if its ripple factor is 20% or less and the mean voltage is within the rated operating voltage range of the Timer.

Connect the power supply voltage through a relay or switch in such a way that the voltage reaches a fixed value at once or the Timer may not be reset or a timer error could result.

For the power supply of an input device, use an isolating transformer, of which the primary and secondary windings are mutually isolated and the secondary winding is not grounded.

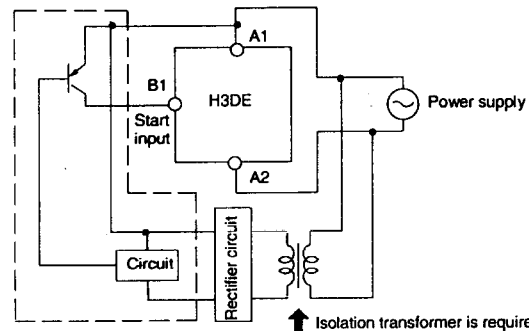

The H3DE-H has a large inrush current; provide sufficient power supply capacity. If the power supply capacity is too small, there may be delays in turning ON the output.

### ■ Installation

If the load current is continuously being supplied to the Timer for a long period of time, be sure to provide the mounting clearance as shown in the figure below. If used under the conditions other than those specified below, the life of internal components may be shortened due to an excessive rise in the internal temperature.

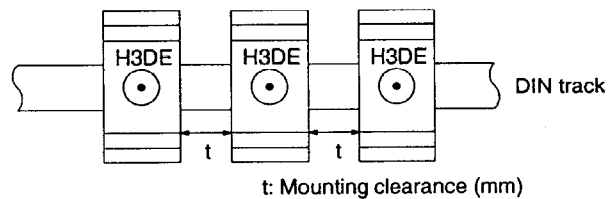

### Input Connections

The inputs of the H3DE-M1/-M2 are voltage (voltage imposition or open) inputs.

**No-contact Input**  
(Connection to PNP output sensor.)

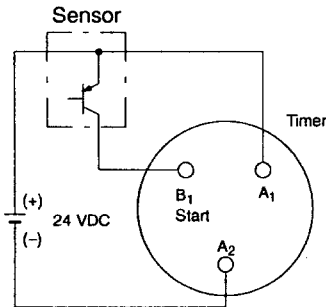

Operates with PNP transistor ON

**No-contact Input**  
(Connection to NPN output sensor.)

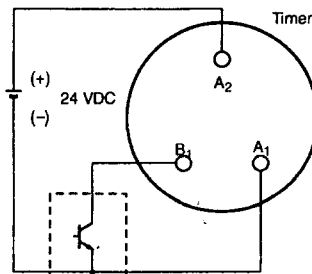

Operates with NPN transistor ON

**Contact Input**

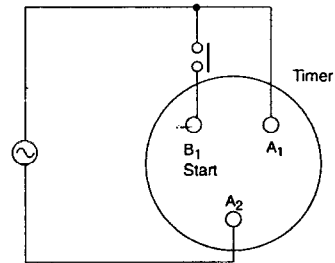

Operates with relay ON

### Voltage Input Signal Levels

No-contact input	1. Transistor ON Residual voltage: 1 V max. (Voltage between terminals B <sub>1</sub> and A <sub>2</sub> must be more than the rated "H-level" voltage (20.4 VDC min..))
	2. Transistor OFF Leakage current: 0.01 mA max. (Voltage between terminals B <sub>1</sub> and A <sub>2</sub> must be less than the rated "L-level" voltage (2.4 VDC max..))
Contact input	Use contacts that can adequately switch 0.1 mA at each voltage to be imposed. (When the contacts are ON or OFF, voltage between terminals B <sub>1</sub> and A <sub>2</sub> must be within the following ranges: When contacts are ON: 20.4 to 253 VAC/DC When contacts are OFF: 0 to 2.4 VAC/DC

# Dimensions

**Note:** All units are in millimeters unless otherwise indicated.

H3DE-M/-S

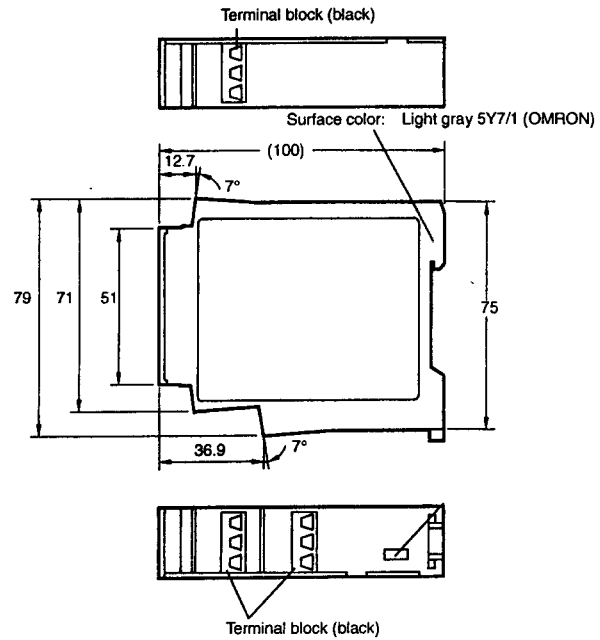
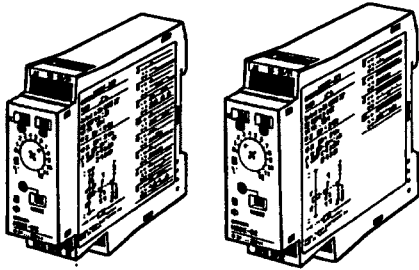

# Installation

## Terminal Arrangement

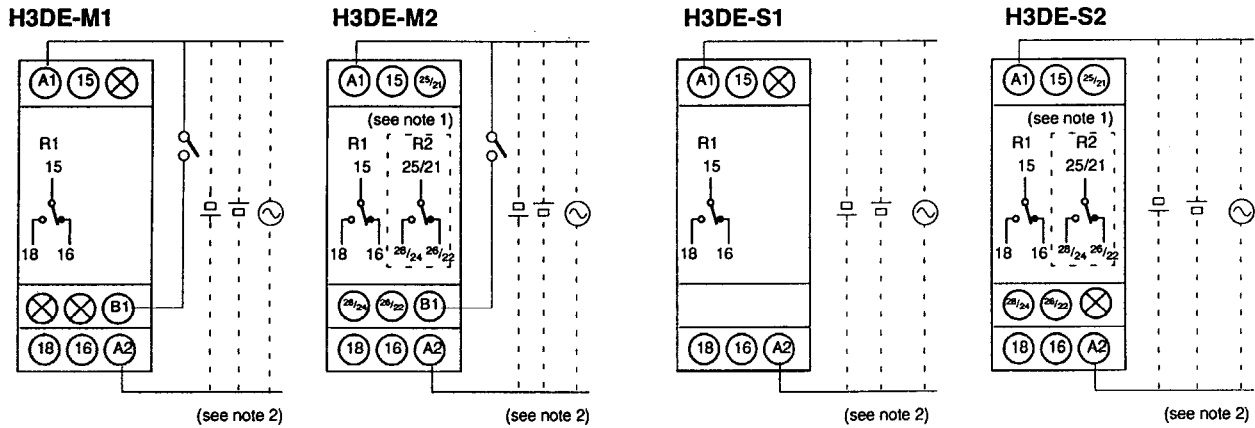

- Note:**
1. The relay R2 can be set to either instantaneous or time-limit contact using the switch located on the bottom of the Timer.
  2. DC supply voltage does not require the designation of polarity.
  3. The contact symbol for the H3DE is indicated with  because it offers multiple operating modes and is different from the delayed contact for conventional timers.