

För icke direkt toleranssatta mått gäller toleransklass
General tolerances if not otherwise stated

NOM DIM MM		TOL CLASS		
From	To	A	B	C
(1)	6	±0.05	±0.1	±0.2
(6)	30	±0.1	±0.2	±0.5
(30)	100	±0.15	±0.3	±0.8
(100)	300	±0.2	±0.5	±1.2
(300)	1000	±0.3	±0.8	±2

Hål / Holes H13

Skarpa kanter brutna där ej annat anges.
No sharp edges unless otherwise specified.

Övriga generella toleranser enligt ritning 4100-4644.
Additional general tolerances in accordance with drawing 4100-4644.

MÄRKT ENLIGT RITNING 4101-0261 D
MARKED IN ACCORDANCE WITH DRAWING 4101-0261 D



Rev	Change order	Change: A = Added W = Was D = Deleted	Date	Sign
3	1014994000	4101-0265 ÄNDRAD/CHANGED	021017	SE
4	1016252000	4101-0261D ÄNDRAD/CHANGED	030508	SE

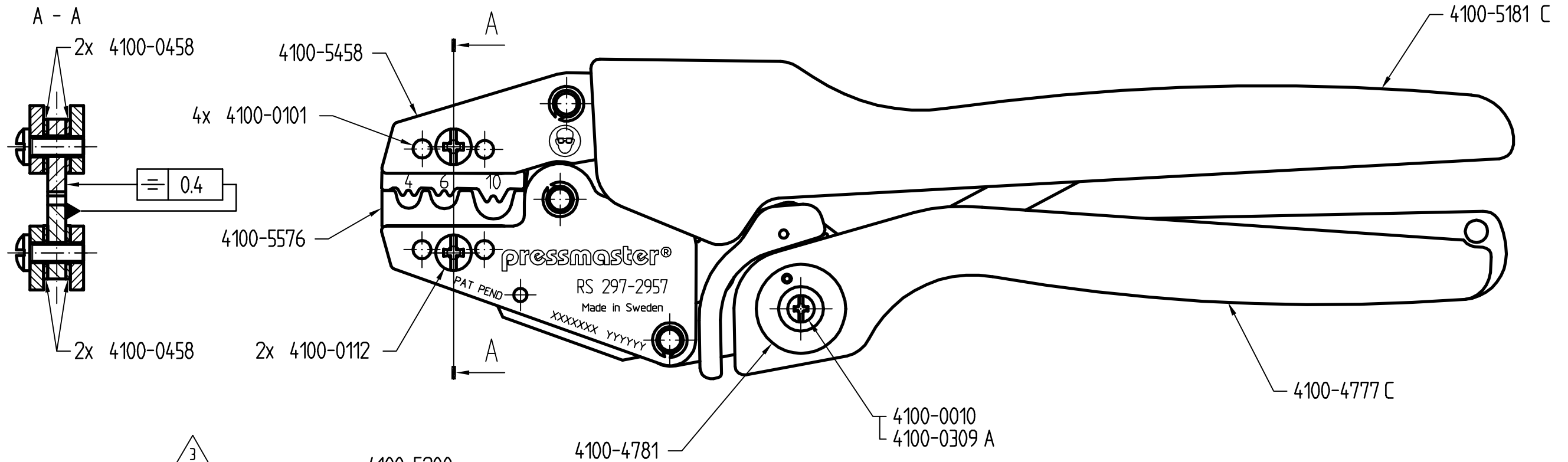
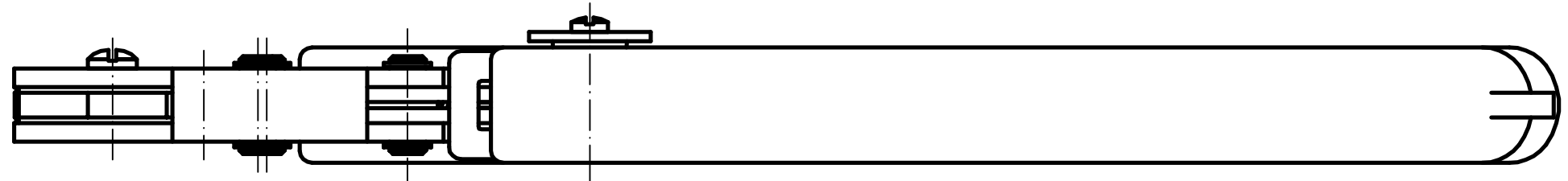

FÖRSPÄNNING / PRELOAD: 180 ± 20 N

Tolkmått / Gauge dimensions (mm)		
URTAG NEST	Gåtolk GO	Stopptolk NO GO
4	Ø3.05	Ø3.30
6	Ø3.10	Ø3.35
10	Ø3.85	Ø4.10

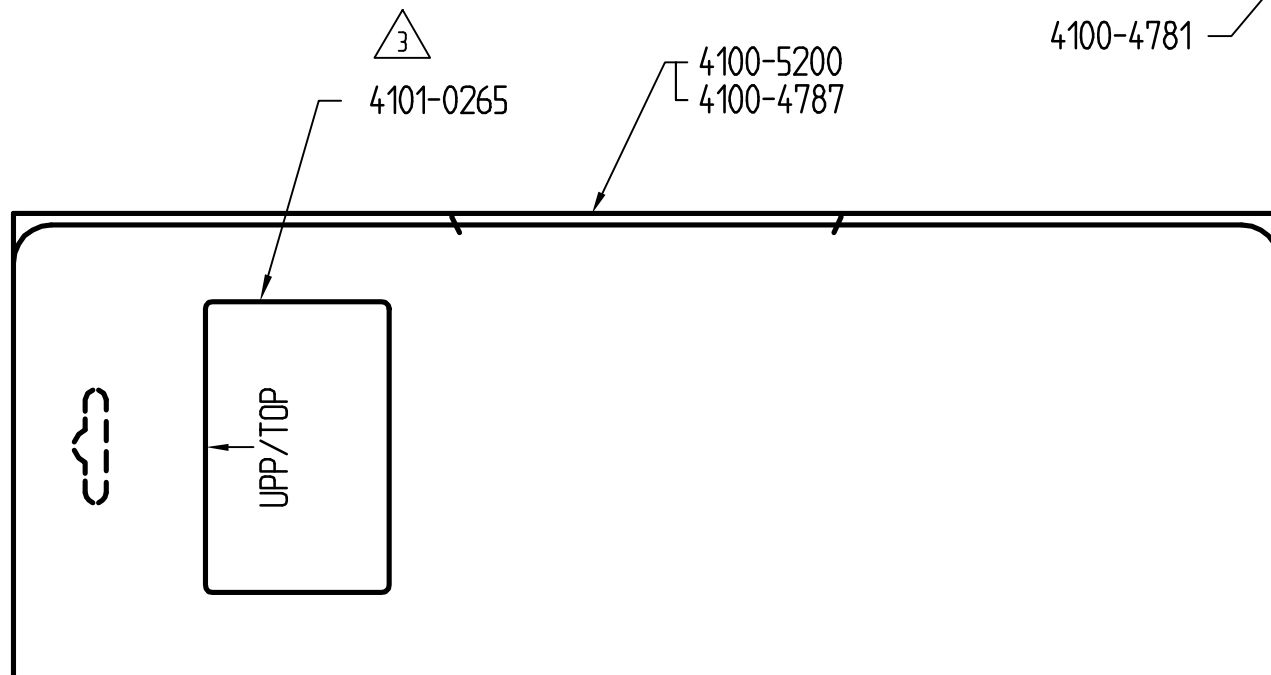

Denna ritning är Pressmaster AB:s egendom. Skyddad av gällande lag.
This drawing is the property of Pressmaster AB. Protected in accordance with prevailing law.

Material		Behandling/Treatment			Status PreLutc.	
Konstr./Design CF	Ritad/Drawn LJ	Datum/Date 980420	Skala/Scale 1:1	Kontr./Checked	Godk./Approved	Anne/Blank
pressmaster®				Benämning/Denomination KRIMPTÅNG 297-2957		Vikt/Weight, gram Art grp 012
REG NR FM13687				CRIMPING TOOL		Ritn nr/Drawing no 43002433 REV 004