

Product datasheet

Specifications



Modicon TM3 Safety module - 3 Function, Cat 4 PL e/SIL CL3 (spring) 24Vdc

TM3SAK6RG

EAN Code: 3606485393049

Main

Range of product	Modicon TM3 Safety
Product or component type	Safety module
Device short name	TM3SAK
Safety module application	For emergency stop, switch, sensing mat/edges or safety light curtain monitoring
Function of module	Emergency stop monitoring 1-channel wiring Emergency stop monitoring 2-channel wiring Monitoring of a movable guard with 2 switches and automatic start Monitoring of a movable guard Multiple emergency stop monitoring 2-channel wiring Proximity sensor monitoring PNP/PNP Proximity sensor monitoring PNP/NPN Sensing mat and edges monitoring Monitoring of electro-sensitive protection equipment (ESPE) PNP/PNP Monitoring of electro-sensitive protection equipment (ESPE) PNP/NPN
Safety level	Can reach PL e/category 4 conforming to ISO 13849-1: 2008 Can reach PL e/category 4 conforming to ISO 13849-2: 2012 Can reach SILCL 3 conforming to IEC 62061: 2005 Can reach SIL 3 conforming to IEC 61508: 2010

Complementary

Safety reliability data	DC = 95 % conforming to ISO 13849-1 PFHd = 5E-9 1/h conforming to IEC 61508-1 1 operation/hour DC-13 24 V DC, <4 A PFHd = 30E-9 1/h conforming to IEC 61508-1 60 operations/hour DC-13 24 V DC, <1 A MTTFd = 500 years conforming to ISO 13849-1 1 operation/hour DC-13 24 V DC, <4 A MTTFd = 85 years conforming to ISO 13849-1 60 operations/hour DC-13 24 V DC, <1 A SFF = 95 % conforming to IEC 61508-1 HFT = 1 conforming to IEC 61508-1 Type = A conforming to IEC 61508-1
Synchronisation time between inputs	Unlimited 2 or 4 s depending of wiring configurable by software
Connections - terminals	Captive spring terminals, removable terminal block 1 x 0.2...1 x 2.5 mm ² flexible without cable end 13-14, 23-24, 33-34 Captive spring terminals, removable terminal block 1 x 0.2...1 x 2.5 mm ² solid without cable end 13-14, 23-24, 33-34 Captive spring terminals, removable terminal block 1 x 0.25...1 x 2.5 mm ² flexible with cable end, with bezel 13-14, 23-24, 33-34 Captive spring terminals, removable terminal block 1 x 0.25...1 x 2.5 mm ² flexible with cable end, without bezel 13-14, 23-24, 33-34 Captive spring terminals, removable terminal block 2 x 0.5...2 x 1.5 mm ² flexible with cable end, with double bezel 13-14, 23-24, 33-34 Captive spring terminals, removable terminal block 1 x 0.14...1 x 1.5 mm ² flexible without cable end other terminals Captive spring terminals, removable terminal block 1 x 0.14...1 x 1.5 mm ² solid without cable end other terminals Captive spring terminals, removable terminal block 1 x 0.25...1 x 0.5 mm ² flexible with cable end, with bezel other terminals Captive spring terminals, removable terminal block 1 x 0.25...1 x 1.5 mm ² flexible with cable end, without bezel other terminals

Output type	Relay instantaneous opening, 3 NO circuit(s), potential free
Number of safety circuits	3 NO for relay instantaneous opening
Maximum switching voltage	230 V utilisation category AC-15 at 50 Hz (relay instantaneous opening) 24 V utilisation category DC-13 (relay instantaneous opening)
[Us] rated supply voltage	24 V - 15...20 % DC
Power consumption in W	0.2 W at 5 V DC 3.6 W at 24 V DC
Input protection type	Internal, electronic
[Uc] control circuit voltage	24 V DC
Maximum cable distance between devices	30 m
Breaking capacity	360 VA holding AC-15 B300 relay output 3600 VA inrush AC-15 B300 relay output
Breaking capacity	4 A 24 V 50 ms DC-13 relay output
Output thermal current	6 A per relay for relay output
[Ith] conventional free air thermal current	18 A
Associated fuse rating	4 A gG or gL for relay output conforming to IEC 60947-5-1 6 A fast blow for relay output conforming to IEC 60947-5-1
Minimum output current	10 mA for relay output
Output voltage	10 V relay output
Maximum response time on input open	40 ms
[Ui] rated insulation voltage	300 V (pollution degree 2) conforming to IEC 60647-5-1
[Uimp] rated impulse withstand voltage	4 kV overvoltage category III conforming to IEC 60647-5-1
Current consumption	100 mA at 24 V DC external supply
Local signalling	8 LEDs (green/red) for user
Electrical connection	Spring terminal
Product compatibility	Safety light curtains conforming to EN/IEC 61496-1 (type 4) Sensing mat/edges conforming to EN 1760-1
Standards	ISO 13849-1:2008 ISO 13849-2:2012 IEC 62061:2005 IEC 61508:2010 IEC 60947-5-1:2010 IEC 61131-2:2007 IEC 60204-1:2005 IEC 60204-1:2009/A1 IEC 61010-1:2010 EN 50581:2012
Product certifications	CSA 61010-2-201 (pending) TÜV CSA Haz Loc Class 1 Division 2 (pending) EAC RCM UL 61010-2-201 ANSI Haz Loc Class 1 Division 2 (pending)
Marking	CSA RCM UL EFUP 10 CE TÜV EAC

Electromagnetic compatibility	<p>Electrostatic discharge immunity test - test level: 8 kV (air discharge) conforming to IEC 61000-4-2</p> <p>Electrostatic discharge immunity test - test level: 6 kV (contact discharge) conforming to IEC 61000-4-2</p> <p>Susceptibility to electromagnetic fields - test level: 10 V/m (80 MHz to 1 GHz) conforming to IEC 61000-4-3</p> <p>Susceptibility to electromagnetic fields - test level: 3 V/m (1.4 GHz...2 GHz) conforming to IEC 61000-4-3</p> <p>Susceptibility to electromagnetic fields - test level: 1 V/m (2 GHz...3 GHz) conforming to IEC 61000-4-3</p> <p>Magnetic field at power frequency - test level: 30 A/m (50...60 Hz) conforming to IEC 61000-4-8</p> <p>Electrical fast transient/burst immunity test - test level: 3 kV (power lines (DC)) conforming to IEC 61000-4-4</p> <p>Electrical fast transient/burst immunity test - test level: 2 kV (I/O) conforming to IEC 61000-4-4</p> <p>1.2/50 μs shock waves immunity test - test level: 1 kV (power lines (DC)) conforming to IEC 61000-4-5</p> <p>Conducted RF disturbances - test level: 10 V (0.15...80 MHz) conforming to IEC 61000-4-6</p> <p>Radiated emission - test level: 40 dBμV/m class A (24 V) conforming to IEC 55011</p> <p>Radiated emission - test level: 47 dBμV/m class A (24 V) conforming to IEC 55011</p>
--------------------------------------	--

Mounting support	<p>Top hat type TH35-7.5 rail conforming to IEC 60715</p> <p>Top hat type TH35-15 rail conforming to IEC 60715</p> <p>wall mount using attached fasteners</p>
-------------------------	---

Height	94 mm
---------------	-------

Depth	73 mm
--------------	-------

Width	43.7 mm
--------------	---------

Net weight	0.19 kg
-------------------	---------

Environment

Standards	<p>EN 1088/ISO 14119</p> <p>IEC 60947-5-1</p> <p>IEC 60947-1</p> <p>IEC 60204-1</p> <p>ISO 13850</p>
------------------	--

Resistance to electrostatic discharge	<p>8 kV in air conforming to IEC 61000-4-2</p> <p>6 kV on contact conforming to IEC 61000-4-2</p>
--	---

Resistance to electromagnetic fields	<p>10 V/m 80 MHz...1 GHz conforming to IEC 61000-4-3</p> <p>3 V/m 1.4 GHz...2 GHz conforming to IEC 61000-4-3</p> <p>1 V/m 2 GHz...3 GHz conforming to IEC 61000-4-3</p>
---	--

Resistance to magnetic fields	30 A/m 50/60 Hz conforming to IEC 61000-4-8
--------------------------------------	---

Resistance to fast transients	<p>3 kV for power lines (DC) (DC) conforming to IEC 61000-4-4</p> <p>2 kV for I/O lines conforming to IEC 61000-4-4</p>
--------------------------------------	---

Surge withstand	<p>1 kV power lines (DC) differential mode conforming to IEC 61000-4-5 DC</p> <p>1 kV power lines (DC) common mode conforming to IEC 61000-4-5 DC</p>
------------------------	---

Resistance to conducted disturbances	10 V 0.15...80 MHz conforming to IEC 61000-4-6
---	--

Electromagnetic emission	<p>Radiated emissions - test level: 50 dBμV/m class A (24 V DC) at 30...230 Hz conforming to IEC 61131-3</p> <p>Radiated emissions - test level: 57 dBμV/m class A (24 V DC) at 230...1000 Hz conforming to IEC 61131-3</p>
---------------------------------	---

Ambient air temperature for operation	-10...55 °C horizontal installation
--	-------------------------------------

Ambient air temperature for storage	-25...70 °C
--	-------------

Relative humidity	<p>10...95 %, without condensation (in operation)</p> <p>10...95 %, without condensation (in storage)</p>
--------------------------	---

IP degree of protection	IP20 (terminals) conforming to IEC 60529
--------------------------------	--

Pollution degree	2
-------------------------	---

Operating altitude	0...2000 m
---------------------------	------------

Storage altitude	0...3000 m
Vibration resistance	+/- 3.5 mm (f= 5...150 Hz) conforming to IEC 60068-2-6
Shock resistance	15 gn for 11 ms conforming to IEC 60068-2-27
Mechanical robustness	Bumps 6 ms 300 shocks (25 gn) conforming to IEC 60068-2-27

Packing Units

Unit Type of Package 1	PCE
Number of Units in Package 1	1
Package 1 Height	7.500 cm
Package 1 Width	10.600 cm
Package 1 Length	12.500 cm
Package 1 Weight	236.000 g
Unit Type of Package 2	S03
Number of Units in Package 2	18
Package 2 Height	30.000 cm
Package 2 Width	30.000 cm
Package 2 Length	40.000 cm
Package 2 Weight	5.344 kg

Logistical informations

Country of origin	FR
--------------------------	----

Contractual warranty

Warranty (in months)	18
-----------------------------	----



Environmental Data

Schneider Electric aims to achieve Net Zero status by 2050 through supply chain partnerships, lower impact materials, and circularity via our ongoing “Use Better, Use Longer, Use Again” campaign to extend product lifetimes and recyclability.

[Environmental Data explained >](#)

[How we assess product sustainability >](#)



Environmental footprint

[Environmental Disclosure](#)

[Product Environmental Profile](#)

Use Better



Materials and Substances

Packaging made with recycled cardboard

Yes

Packaging without single use plastic

Yes

SCIP Number

99cae485-192a-4a91-bc99-8cce8f6405e4

EU RoHS Directive

[Compliant By Exemption](#)

REACH Regulation

[Reference contains Substances of Very High Concern above the threshold](#)

PVC free

Yes

Use Longer



Lifetime extension

Repair

No

Use Again



Repack and remanufacture

End of life manual availability

[End of Life Information](#)

Take-back

Nej

WEEE Label

 The product must be disposed on European Union markets following specific waste collection and never end up in rubbish bins

Dimensions Drawings

Dimensions

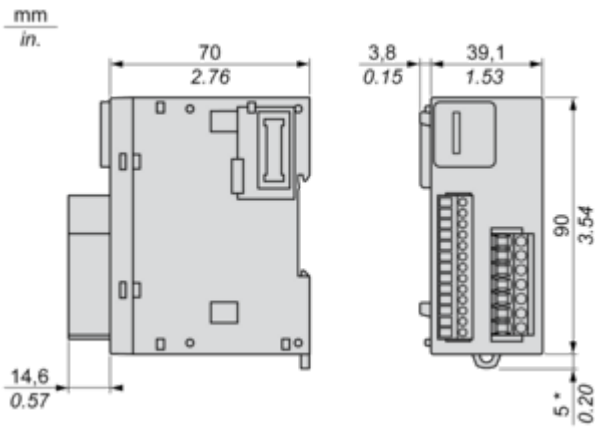

(*) 8.5 mm/0.33 in when the clamp is pulled out.

Mounting and Clearance

Spacing Requirements

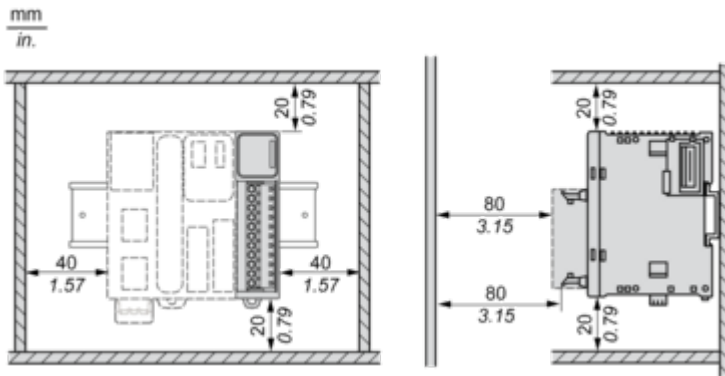

Mounting on a Rail

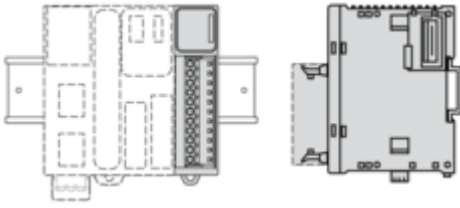

Incorrect Mounting

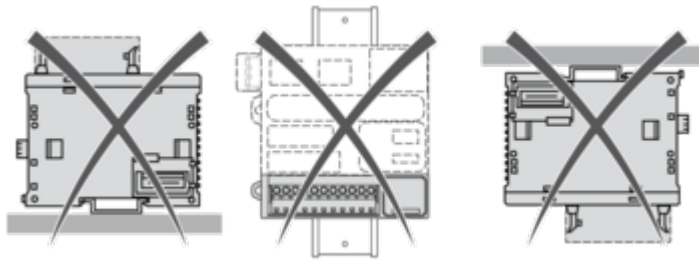

Mounting on a Panel Surface

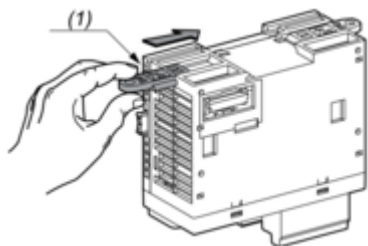

(1) Install a mounting strip

Mounting Hole Layout

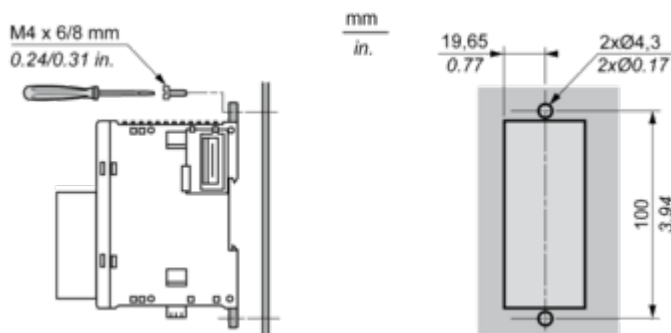

Connections and Schema

Emergency Stop Wiring Diagram

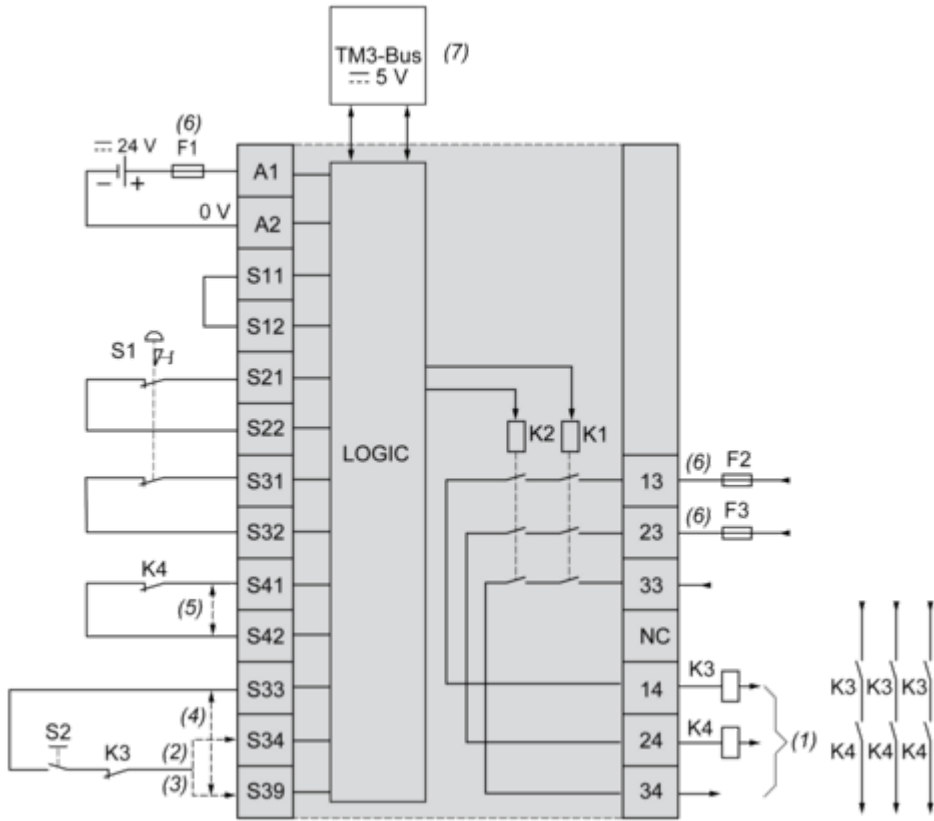

S1 : Emergency stop switch

S2 : Start switch

(1) Safety outputs

(2) Monitored start

(3) Non-monitored start

(4) For automatic start, directly connect [S33] and [S39] terminals

(5) Second external device monitoring channel. Connect [S41] and [S42] terminals if not used

(6) Fuses. Refer to technical specifications for fuse values

(7) Non-safety related TM3 Bus communication with logic controller

Protective Guard Wiring

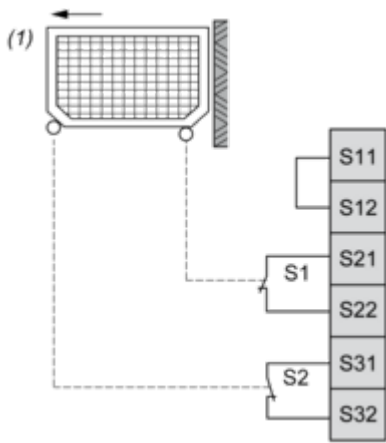

(1) Protective guard

Electro-Sensitive Protective Equipment (ESPE) Wiring

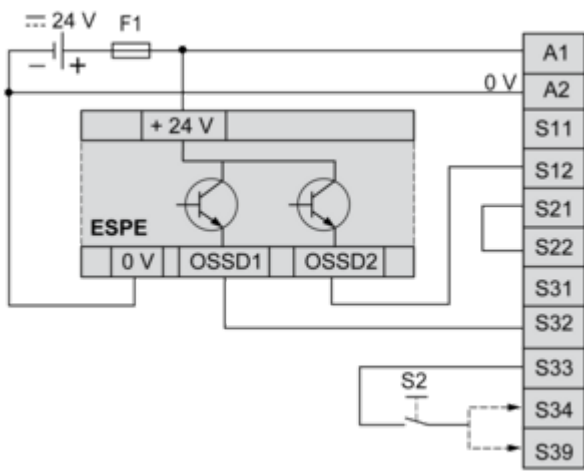

S2: Start switch

NOTE: The ESPE must be supplied by the same PELV/SELV power supply as the safety module.

Safety-Mat Wiring

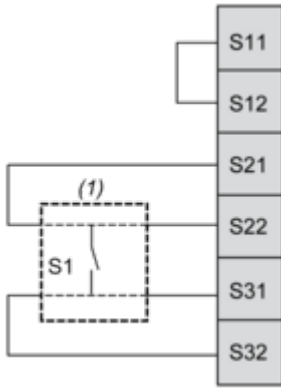

(1) Safety-mat

NOTE: Normally, most safety-mats are maladapted for use in combination with the automatic start mode. In addition, if you use the safety-mat in your application which includes the automatic startmode, you should consider this in your risk analysis.

Emergency Stop Wiring

One Channel

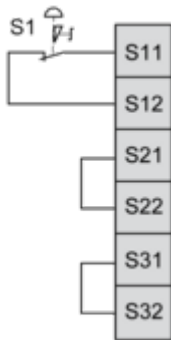

S1: Emergency stop switch

Two Channel

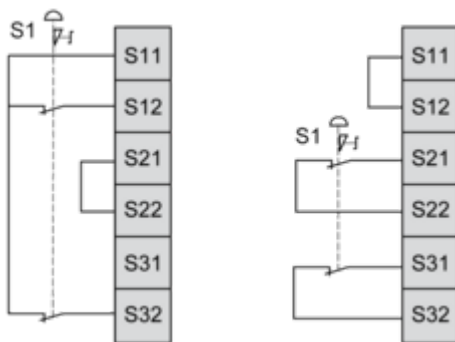

S1: Emergency stop switch

NOTE: Inputs S11 and S12 are not intended for the monitoring of short circuits in external wiring.

Proximity Sensors Wiring

Without Short Circuit Detection

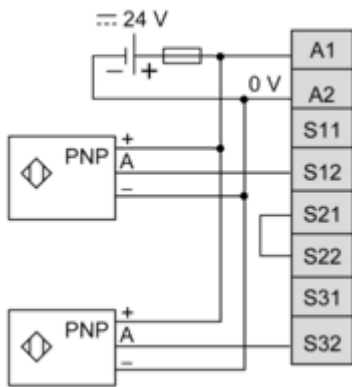

NOTE: The sensors must be supplied by the same PELV/SELV power supply as the safety module.

With Short Circuit Detection

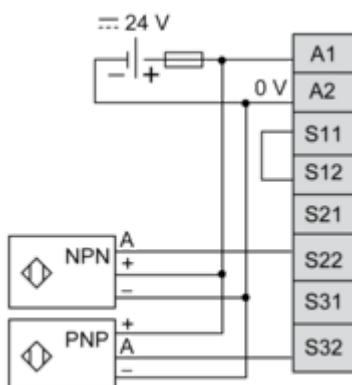

NOTE: The sensors must be supplied by the same PELV/SELV power supply as the safety module.

Synchronization Time Monitoring Chronogram

2 Channel Application

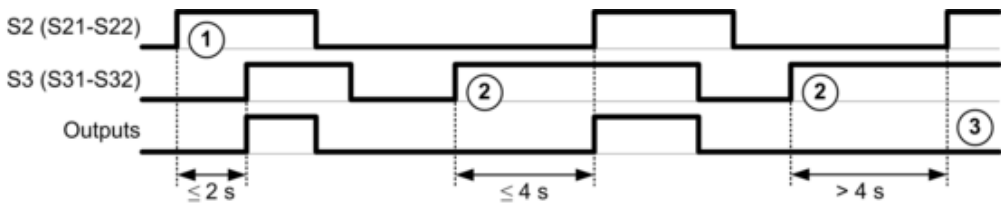

- 1 : S2 operated before S3
- 2 : S3 operated before S2
- 3 : Outputs are not activated because the synchronization time is expired.

Image of product / Alternate images

Alternative

