

MODEL CSSG1 – MODULAR CONTROLLER SERIES STRAIN GAGE MODULE



- STRAIN GAGE MODULE FOR THE MODULAR CONTROLLER SERIES
- HOT-SWAPPABLE REPLACEMENT REDUCES DOWNTIME
- AUTO ADDRESSING MINIMIZES CONFIGURATION TIME
- PID CONTROL WITH REDUCED OVERSHOOT
- LOAD CELL, PRESSURE AND TORQUE BRIDGE INPUTS
- SOFTWARE SELECTABLE LOW LEVEL INPUTS (20 mV, 33 mV or 200 mV FULL SCALE)
- SOFTWARE SELECTABLE 5 VDC or 10 VDC BRIDGE EXCITATION
- DIGITAL TARE (re-zero), BATCH TOTALIZER, AND PEAK/VALLEY (max/min) RECORDING
- ON DEMAND AUTO-TUNING OF PID SETTINGS
- DC ANALOG OUTPUT
- WINDOWS® CONFIGURATION SOFTWARE



GENERAL DESCRIPTION

The Model CSSG is a full featured single loop PID controller designed for use with the Modular Controller Series. The module accepts low level signals from a variety of bridge-type transducers, such as load cells, pressure transducers, torque transducers, etc. An optional second signal input is available, providing math capabilities between the two input channels (average, differential, etc.). Each input channel provides a software selectable 5 V or 10 V stable bridge excitation voltage, capable of driving up to four 350 Ω bridges (combined total per module). The inputs are software selectable for ±20 mV, ±33 mV, or ±200 mV full scale. With solid state or relay outputs, plus an analog output, the CSSG module can perform virtually any combination of time-proportioning or linear control. The discrete outputs may also be assigned to one of seven internal soft alarms; and the linear output can be assigned to transmit virtually any internal variable. In addition, digital tare (re-zero), batch totalizer, and peak/valley (max/min) are provided.

The modules connect and communicate via a backplane connection to the CSMSTR Master module. The Master, equipped with serial ports as well as an Ethernet port, allows the system to share data with PCs, PLCs, and SCADA systems. The Master supports up to 16 CS Series modules (when using CSSG modules, refer to “Power” specifications).

The CSSG modules are available with relays, or open drain MOSFET outputs. For applications requiring large loads to be controlled, several DIN rail mount relays are available.

The modules can operate in On/Off, P, PI, or PID control mode, and use an on-demand Auto-Tune that establishes the tuning constants. The PID constants may be fine-tuned through the serial or Ethernet interface. The modules employ a unique overshoot suppression feature, which allows the quickest response without excessive overshoot. The modules can also be operated in manual mode, providing the operator with direct control of the output.

Internal power management circuits allow the modules to be replaced while power is applied, which reduces downtime in the event of a relay failure. All configuration information is stored locally within each module, as well as in the Master, so replacement modules do not need to be configured.

The Modular Controller Series’ high density packaging and DIN rail mounting saves time and panel space. The backplane connection provides power and communication to the module and snaps easily onto standard top hat (T) profile DIN rail.

CONFIGURATION

The Modular Controller Series is configured with Windows® compatible Crimson® software. The software is an easy to use, graphical interface which provides a means of configuration and commissioning of new systems, as well as routine module re-calibration.

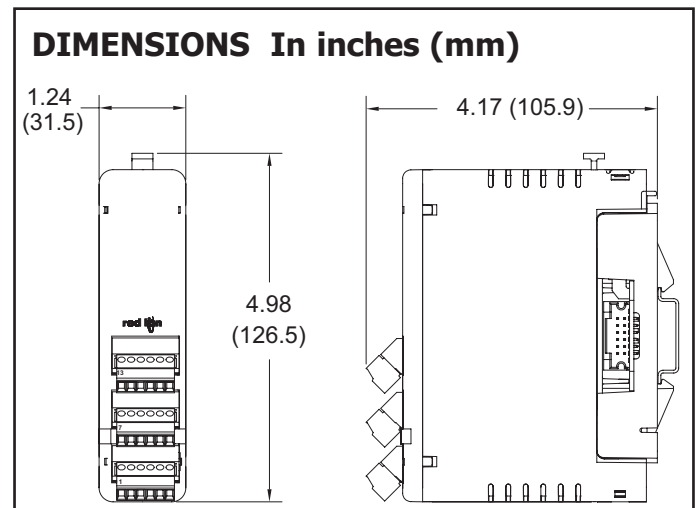

SAFETY SUMMARY

All safety related regulations, local codes and instructions that appear in the manual or on equipment must be observed to ensure personal safety and to prevent damage to either the instrument or equipment connected to it. If equipment is used in a manner not specified by the manufacturer, the protection provided by the equipment may be impaired.

Do not use the controller to directly command motors, valves, or other actuators not equipped with safeguards. To do so can be potentially harmful to persons or equipment in the event of a fault to the controller.

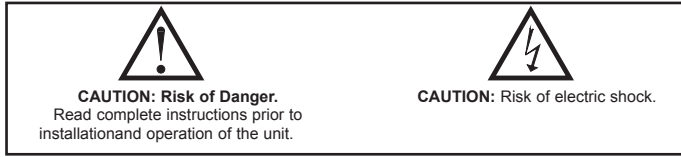

SPECIFICATIONS

- POWER:** Derived from system backplane. 250 mA max. load on power input of MASTER. Module may be hot-swapped (replaced while powered up).
Modules per Master: A single Master can support up to 11 CSSG1 modules combined with any 5 other module types. For applications that require more than 11 CSSG1 modules, please contact technical support.
- LEDs*:**
STS - Status LED shows module condition.
OP1, OP2, OP3 - Indicate status of outputs 1, 2, and 3
ALM - Alarm LED is lit during an internal alarm condition.
* Default configuration.
- MEMORY:** Non-volatile memory retains all programmable parameters. The MASTER also stores the parameters in order to reprogram any modules that are replaced.
- INPUTS:**

SOFTWARE SELECTABLE INPUT RANGE	ACCURACY * 18 TO 28°C 10 TO 75% RH	ACCURACY * 0 TO 50°C 0 TO 85% RH
±20.000 mVDC	0.02% of reading +3 µV	0.07% of reading +4 µV
±33.000 mVDC	0.02% of reading +5 µV	0.07% of reading +7 µV
±200.00 mVDC	0.02% of reading +30 µV	0.07% of reading +40 µV

* After 20 minute warm-up. Accuracy over the 0 to 50°C range includes the temperature coefficient.

Connection Type:

- 4-wire bridge (differential)
- 2-wire (single-ended)

Sample Time: 67 msec (15 readings per second)

Common Mode Range (with respect to input common): 0 to +5 VDC

Common Mode Rejection: > 100 dB, DC to 120 Hz

Temperature Coefficient (ratio metric): 20 ppm/°C max.

Step Response Time: 200 msec max. to within 99% of final process value

Input Impedance: 100 MΩ

Max Continuous Overload: 30 V

PV Range: -30,000 to 30,000

Effective Resolution: 16-bit

5. BRIDGE EXCITATIONS:

Software selectable:

5 VDC, ±2%, 65 mA max.

10 VDC, ±2%, 125 mA max. combined (excitation 1 plus excitation 2).

Temperature coefficient (ratio metric): 20 ppm/°C max.

Max. four 350Ω bridges per module.

6. ISOLATION LEVEL: 500 Vrms @ 50/60 Hz for 1 minute between the following:

OP1 * OP2 * OP3

Linear Output

Signal Inputs (the 2 input channels are not isolated from each other)

CS Master Power Supply Input

* Outputs OP1 and OP2 of SSR model are not isolated from each other

7. COMMUNICATIONS: Provided by the CS Master.

8. DISCRETE OUTPUTS:

Outputs 1 and 2 are available as Solid State NFET, or Form A relay. Output 3 is a Form C relay.

Solid State Output:

Type: Switched DC, N Channel open drain MOSFET

Current Rating: 1 A max

VDS ON: 0.3 V @ 1 A

VDS MAX: 30 VDC

Offstate Leakage Current: 0.5 mA max

Form A Relay Output:

Type: N.O.

Current Rating: 3 Amps @ 125 VAC

1/10 HP @ 125 VAC

Life Expectancy: 200,000 cycles at maximum load rating. (Decreasing load, increasing cycle time, and use of surge suppression such as RC snubbers increases life expectancy.)

Form C Relay Output:

Type: SPDT

Current Rating: 5 Amps @ 125 VAC or 28 VDC (resistive load)

1/8 HP @ 125 VAC

Life Expectancy: 100,000 cycles at maximum load rating. (Decreasing load, increasing cycle time, and use of surge suppression such as RC snubbers increases life expectancy.)

9. CONTROL MODES:

Control: On/Off, P, PI, or PID

Output: Time proportioning or linear

Cycle Time: Programmable from 0.0 to 60.0 sec

Auto-Tune: When selected, sets proportional band, integral time, derivative time values, and output dampening time

Input Fault Response: Upscale

10. ALARMS:

Modes: Manual

Absolute High Acting

Absolute Low Acting

Deviation High Acting

Deviation Low Acting

Inside Band Acting

Outside Band Acting

Reset Action: Programmable; automatic or latched

Standby Mode: Programmable; enable or disable

Hysteresis: Programmable

Input Fault Response: Upscale

11. ANALOG DC OUTPUT:

Jumper Selectable/programmable for 0-10 VDC, 0-20 mA, or 4-20 mA

Resolution:

Voltage: 500 µV

Current: 1 µA

Accuracy:

0.1% of full scale (18 to 28°C)

0.2% of full scale (0 to 50°C)

Update Time: 0.0 to 60.0 sec

Compliance (for current output only): 500 Ω max.

Minimum load (voltage output only): 10 KΩ min.

Output is independently jumper selectable for either 10 V or 20 mA. The output range may be field calibrated to yield approximate 10% overrange and a small underrange (negative) signal.

12. ENVIRONMENTAL CONDITIONS:

Operating Temperature Range: 0 to +50°C

Storage Temperature Range: -40 to +85°C

Operating and Storage Humidity: 85% max relative humidity, non-condensing, from 0 to +50°C

Vibration to IEC 68-2-6: 10 to 150 Hz, 1 g.

Shock to IEC 68-2-27: Operational 25 g (10 g relay).

Altitude: Up to 2000 meters

13. CERTIFICATIONS AND COMPLIANCES:

CE Approved

EN 61326-1 Immunity to Industrial Locations

Emission CISPR 11 Class A

Safety requirements for electrical equipment for measurement, control, and laboratory use:

EN 61010-1: General Requirements

EN 61010-2-030: Particular Requirements for Testing and Measuring Circuits

EN 61010-2-201: Particular Requirements for Control Equipment

RoHS Compliant

UL Listed: File #E302106

ABS Certificate #09-HS426719-B-4-PDA

Refer to EMC Installation Guidelines section of the bulletin for additional information.

14. CONSTRUCTION: Case body is burgundy high impact plastic. For indoor use only. Installation Category II, Pollution Degree 2.

15. CONNECTIONS: Removable wire clamp screw terminal blocks.

Wire Gage: 28-16 AWG terminal gage wire

Torque: 1.96-2.23 inch/lbs (0.22-0.25 N-m)

16. MOUNTING: Snaps on to standard DIN style top hat (T) profile mounting rails according to EN50022 -35 x 7.5 and -35 x 15.

17. WEIGHT: 7 oz (198.4 g)

BLOCK DIAGRAM

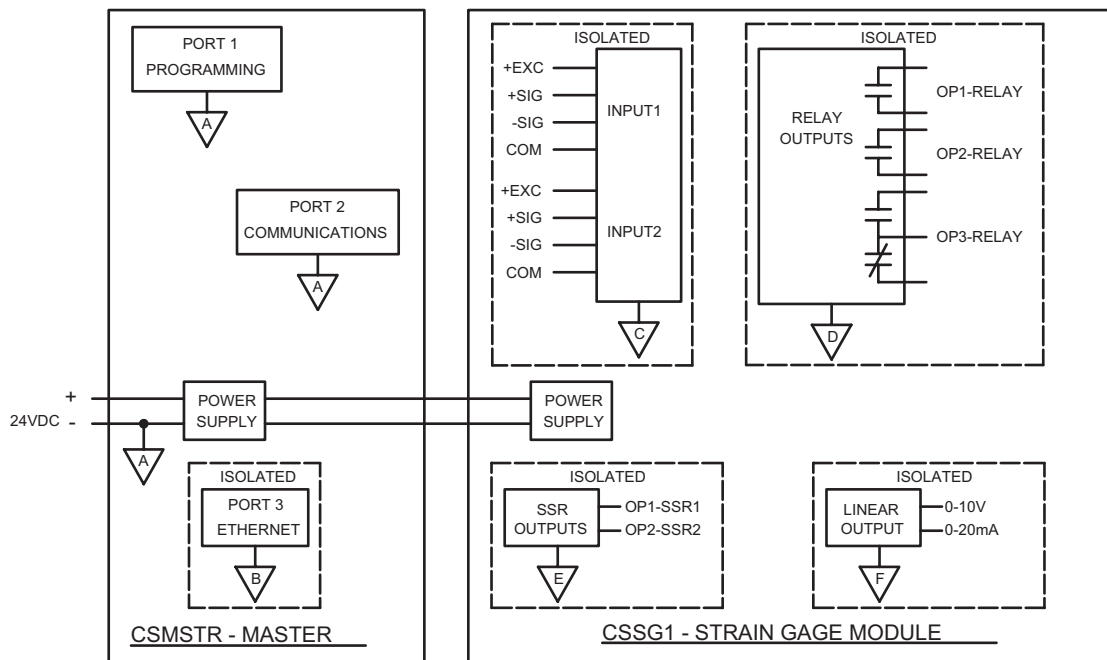

EMC INSTALLATION GUIDELINES

Although Red Lion Controls Products are designed with a high degree of immunity to Electromagnetic Interference (EMI), proper installation and wiring methods must be followed to ensure compatibility in each application. The type of the electrical noise, source or coupling method into a unit may be different for various installations. Cable length, routing, and shield termination are very important and can mean the difference between a successful or troublesome installation. Listed are some EMI guidelines for a successful installation in an industrial environment.

1. A unit should be mounted in a metal enclosure, which is properly connected to protective earth.
2. Use shielded cables for all Signal and Control inputs. The shield connection should be made as short as possible. The connection point for the shield depends somewhat upon the application. Listed below are the recommended methods of connecting the shield, in order of their effectiveness.
 - a. Connect the shield to earth ground (protective earth) at one end where the unit is mounted.
 - b. Connect the shield to earth ground at both ends of the cable, usually when the noise source frequency is over 1 MHz.
3. Never run Signal or Control cables in the same conduit or raceway with AC power lines, conductors, feeding motors, solenoids, SCR controls, and heaters, etc. The cables should be run through metal conduit that is properly grounded. This is especially useful in applications where cable runs are long and portable two-way radios are used in close proximity or if the installation is near a commercial radio transmitter. Also, Signal or Control cables within an enclosure should be routed as far away as possible from contactors, control relays, transformers, and other noisy components.
4. Long cable runs are more susceptible to EMI pickup than short cable runs.
5. In extremely high EMI environments, the use of external EMI suppression devices such as Ferrite Suppression Cores for signal and control cables is

effective. The following EMI suppression devices (or equivalent) are recommended:

Fair-Rite part number 0443167251 (RLC part number FCOR0000)

Line Filters for input power cables:

Schaffner # FN2010-1/07 (Red Lion Controls # LFIL0000)

6. To protect relay contacts that control inductive loads and to minimize radiated and conducted noise (EMI), some type of contact protection network is normally installed across the load, the contacts or both. The most effective location is across the load.
 - a. Using a snubber, which is a resistor-capacitor (RC) network or metal oxide varistor (MOV) across an AC inductive load is very effective at reducing EMI and increasing relay contact life.
 - b. If a DC inductive load (such as a DC relay coil) is controlled by a transistor switch, care must be taken not to exceed the breakdown voltage of the transistor when the load is switched. One of the most effective ways is to place a diode across the inductive load. Most RLC products with solid state outputs have internal zener diode protection. However external diode protection at the load is always a good design practice to limit EMI. Although the use of a snubber or varistor could be used.
RLC part numbers: Snubber: SNUB0000
Varistor: ILS11500 or ILS23000
7. Care should be taken when connecting input and output devices to the instrument. When a separate input and output common is provided, they should not be mixed. Therefore a sensor common should NOT be connected to an output common. This would cause EMI on the sensitive input common, which could affect the instrument's operation.

Visit RLC's web site at <http://www.redlion.net/emi> for more information on EMI guidelines, Safety and CE issues as they relate to Red Lion Controls products.

HARDWARE

ANALOG OUTPUT OPTION

Select either Voltage or Current output by placing the output jumpers in the appropriate location. The output jumpers are located on the side of the CSSG1 module.

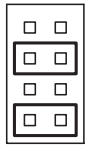

Current

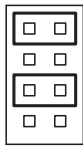

Voltage

INSTALLATION

SEPARATE BASE FROM MODULE

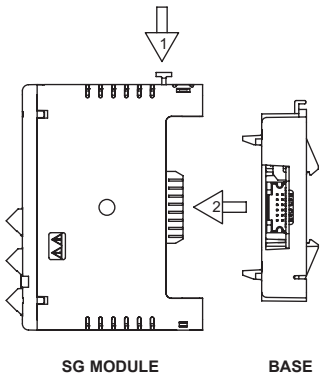

ATTACH THE MODULE BASE TO THE DIN RAIL

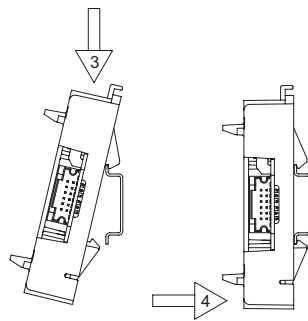

ATTACH MODULE TO BASE

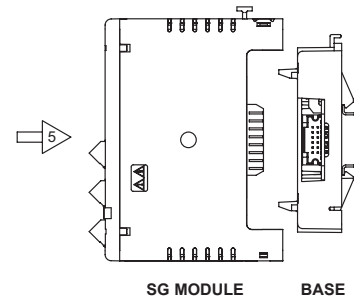

WIRING

WIRING CONNECTIONS

All conductors should meet voltage and current ratings for each terminal. Also, cabling should conform to appropriate standards of good installation, local codes and regulations. When wiring the module, use the numbers on the label to identify the position number with the proper function. Strip the wire, leaving approximately 1/4" (6 mm) of bare wire exposed. Insert the wire into the terminal, and tighten.

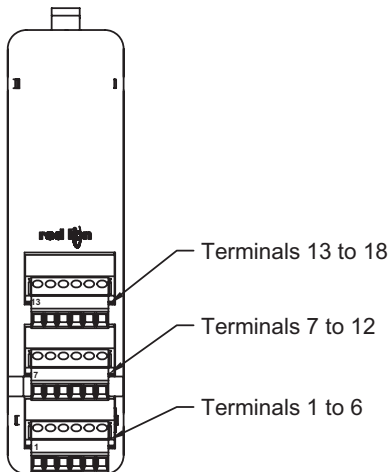

OP3 COM.	OP3 N.O.	OP3 N.C.	N/C	ANALOG+	ANALOG-
13	14	15	16	17	18
□	□	□	□	□	□

(OPT.)

OP1 COM.	OP1 +	OP2 COM.	OP2 +	+SIG.	+EXC.
7	8	9	10	11	12
□	□	□	□	□	□

(OPT.)

COM.	-SIG.	+SIG.	+EXC.	COM.	-SIG.
1	2	3	4	5	6
□	□	□	□	□	□

INPUT CONNECTIONS

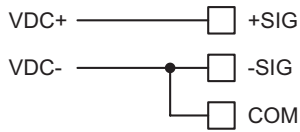

2-Wire Single Ended Input

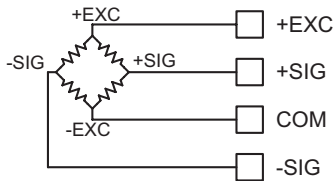

4-Wire Bridge Input

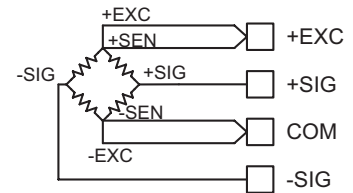

6-Wire Bridge Input

BRIDGE COMPLETION RESISTORS

For single strain gage applications, bridge completion resistors must be employed externally to the module. Only use metal film resistors with a low temperature coefficient of resistance.

Load cells and pressure transducers are normally implemented as full resistance bridges and do not require bridge completion resistors.

OUTPUT CONNECTIONS

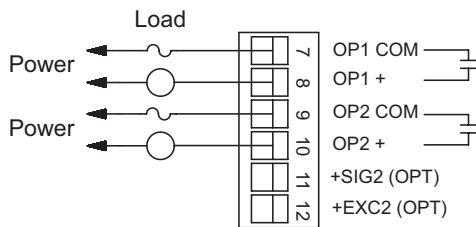

Outputs 1 and 2 - Relay Version

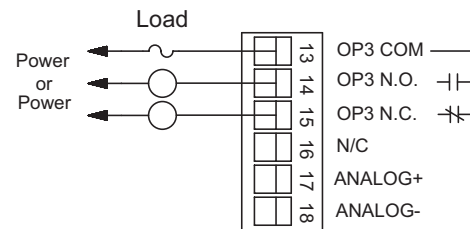

Output 3

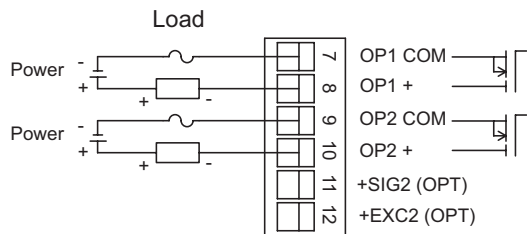

Outputs 1 and 2 - Solid State Version

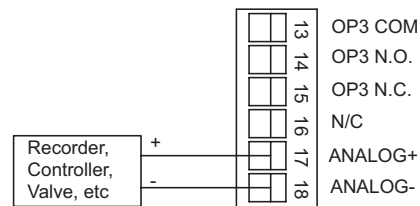

Analog Output

LEDS

STS – STATUS LED

The Status LED is a dual color LED that provides information regarding the state of the module. This includes indication of the various stages of the start-up routine (power-up), as well as any errors that may occur.

Startup Routine

Rapidly Flashing Red	Module is currently running the boot loader and/or being flash upgraded by Crimson. This occurs for four seconds during a power up.
Steady Red	Module switching to configuration.
Green	Module performing normally.

Error States

Solid Red	Module not controlling, and not communicating.
Green/Pulsing Red	Module is controlling properly, but has lost communication with the Master.

OP1, OP2, OP3, – OUTPUT STATUS LED

The OP1, OP2, and OP3 LEDs are factory configured to indicate the status of the outputs. The LEDs turn on when the output is active.

These LEDs may be remapped to various other module properties.

ALM – ALARM LED

The Alarm LED is factory configured to indicate the presence of an alarm. Whenever one of the seven alarms is active, the LED turns on.

This LED may be remapped to various other module properties.

FIRMWARE UPGRADE

The module's firmware is stored in flash memory to prevent software/hardware conflicts, and so that software features may be added in the future.

During a download, Crimson compares its own library of firmware files with those stored in the Master module. If they do not match, Crimson will download the necessary files. The Master then checks to make sure that the I/O modules contain the same firmware. If they contain a different revision, the Master will automatically copy those files into the module's flash memory. During this process, the module LEDs will flash rapidly, starting with the top row, and progressing through the remaining rows until the process is complete.

CONFIGURATION

Programming is done via Crimson[®] software, a Windows[®] compatible configuration interface. Please see the Crimson manual for more information.

ORDERING INFORMATION

TYPE	MODEL NO.	DESCRIPTION	PART NUMBER
Master Module	CSMSTR	Modular Controller Master, Multi Comms ports and Ethernet	CSMSTRV2
		Modular Controller Master with multiple protocol converter, data logger, web server with Virtual HMI up to QVGA (320 x 240) size and expansion slot.	CSMSTRSX
		Modular Controller Master with multiple protocol converter, data logger, web server with Virtual HMI up to VGA (640 x 480) size and expansion slot with increased SDRAM	CSMSTRGT
Strain Gage Control Modules	CSSG1 ¹	Single Loop, One SG Input, Relay Outputs, Analog Out	CSSG10RA
		Single Loop, One SG Input, Solid State Outputs, Analog Out	CSSG10SA
		Single Loop, Two SG Inputs, Relay Outputs, Analog Out	CSSG11RA
		Single Loop, Two SG Inputs, Solid State Outputs, Analog Out	CSSG11SA
Communications Cables (10 feet)	CBL	Programming Cable for CS, G3, & Paradigm Series	CBLPROG0
		Communications Cables ¹	CBLxxxx
Software		Crimson [®] Programming Software ²	SFCRM
		Crimson [®] Programming Software, Manual, and Download Cable	SFCRK
Accessories		Rail Stops (Qty 2)	RSRSTP00
		Replacement Base	CSBASE00
		Replacement Termination Plug	CSTERM00

¹ Visit www.redlion.net for a complete list of PID modules, data acquisition modules, communications drivers and cables.

² Free at www.redlion.net

This page intentionally left blank

LIMITED WARRANTY

The Company warrants the products it manufactures against defects in materials and workmanship for a period limited to two years from the date of shipment, provided the products have been stored, handled, installed, and used under proper conditions. The Company's liability under this limited warranty shall extend only to the repair or replacement of a defective product, at The Company's option. The Company disclaims all liability for any affirmation, promise or representation with respect to the products.

The customer agrees to hold Red Lion Controls harmless from, defend, and indemnify RLC against damages, claims, and expenses arising out of subsequent sales of RLC products or products containing components manufactured by RLC and based upon personal injuries, deaths, property damage, lost profits, and other matters which Buyer, its employees, or sub-contractors are or may be to any extent liable, including without limitation penalties imposed by the Consumer Product Safety Act (P.L. 92-573) and liability imposed upon any person pursuant to the Magnuson-Moss Warranty Act (P.L. 93-637), as now in effect or as amended hereafter.

No warranties expressed or implied are created with respect to The Company's products except those expressly contained herein. The Customer acknowledges the disclaimers and limitations contained herein and relies on no other warranties or affirmations.

Red Lion Controls
Headquarters
20 Willow Springs Circle
York PA 17406
Tel +1 (717) 767-6511
Fax +1 (717) 764-0839

Red Lion Controls
Europe
Softwareweg 9
NL - 3821 BN Amersfoort
Tel +31 (0) 334 723 225
Fax +31 (0) 334 893 793

Red Lion Controls
India
201-B, 2nd Floor, Park Centra
Opp 32 Mile Stone, Sector-30
Gurgaon-122002 Haryana, India
Tel +91 984 487 0503

Red Lion Controls
China
Unit 1102, XinMao Plaza
Building 9, No.99 Tianzhou Road
ShangHai, P.R. China 200223
Tel +86 21 6113 3688
Fax +86 21 6113 3683