

THIS DRAWING IS UNPUBLISHED. RELEASED FOR PUBLICATION 20
 © COPYRIGHT 20 BY TYCO ELECTRONICS CORPORATION. ALL RIGHTS RESERVED.

LOC	DIST	REVISIONS					
		P	LTR	DESCRIPTION	DATE	DWN	APVD
E	B		0	RELEASE TO PRODUCTION	25/02/92	RR	PT
			A	EB00-0065-02	21/02/02	MJG	BB
			B	EB00-0158-02	28/05/02	MJG	BB
			-	-	-	-	-

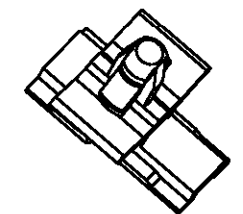
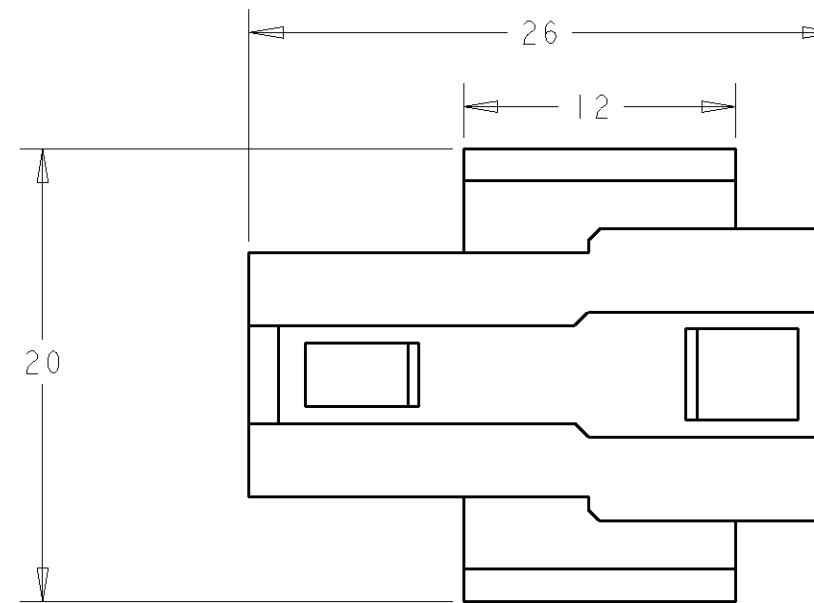
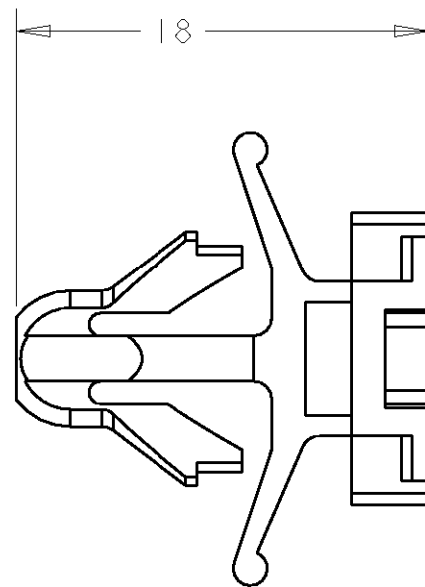
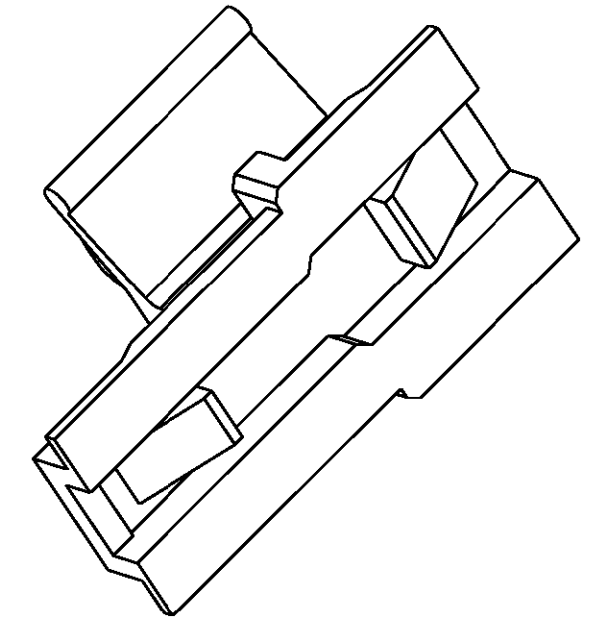
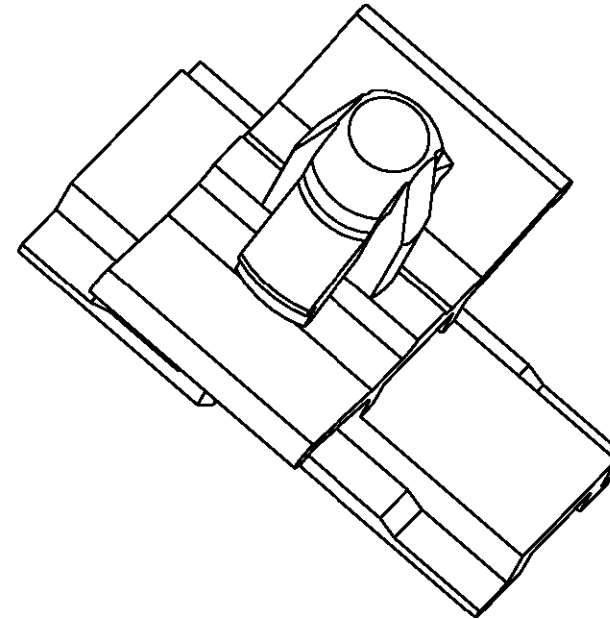
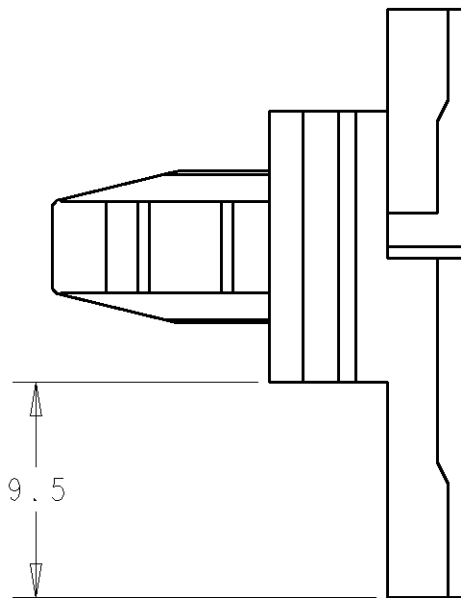

SCALE 1:1

NOTE:
 PRODUCT MAY EXHIBIT A GREEN TINGE DUE TO COPPER SALTS
 IN THE NATURAL RESIN MATERIAL ON PART NUMBER 345484-1

PANEL THICKNESS - 0.8 - 1.6mm
 PANEL HOLE SIZE - 6.5 - 7.0 mm
 MINIMUM PULL OUT FORCE - 10 KG

NATURAL	NYLON 66	345484-1
COLOUR	MATERIAL	PART NUMBER

<small>THIS DRAWING IS A CONTROLLED DOCUMENT FOR TYCO ELECTRONICS CORPORATION IT IS SUBJECT TO CHANGE AND THE CONTROLLING ENGINEERING ORGANIZATION SHOULD BE CONTACTED FOR THE LATEST REVISION.</small>		DWN R. RUNAGAL 14AUG1990 CHK P. TANNER 14AUG1990 APVD J. PALMER 14AUG1990		tyco Electronics Tyco Electronics UK Ltd, Stanmore, Middx, HA7 4RS.	
DIMENSIONS: mm		TOLERANCES UNLESS OTHERWISE SPECIFIED: 0 PLC ±- 1 PLC ±0.5 2 PLC ±0.5 3 PLC ±0.5 4 PLC ±- ANGLES ±5		NAME DUAL PURPOSE BODY CLIP FOR 040 OR 070 MULTILOCK HOUSINGS	
MATERIAL -		FINISH -		PRODUCT SPEC - APPLICATION SPEC - WEIGHT -	
		CUSTOMER DRAWING		SIZE A3 CAGE CODE 00779 DRAWING NO C-345484 RESTRICTED TO -	
				SCALE 3:1 SHEET 1 OF 1 REV B	