

TC74AC166P, TC74AC166F, TC74AC166FN

8-Bit Shift Register (P-IN, S-OUT)

The TC74AC166 is an advanced high speed CMOS 8-BIT PARALLEL/SERIAL-IN, SERIAL-OUT SHIFT REGISTER fabricated with silicon gate and double-layer metal wiring C²MOS technology.

It achieves the high speed operation similar to equivalent Bipolar Schottky TTL while maintaining the CMOS low power dissipation.

It consists of parallel-in or serial-in, serial-out 8-bit shift register with a gated clock input and an overriding clear input. The parallel-in or serial-in modes are controlled by the SHIFT/LOAD input. When the SHIFT/LOAD input is held high, the serial data input is enabled and the eight flip-flops perform serial shifting on each clock pulse. When held low, the parallel data inputs are enabled and synchronous loading occurs on the next clock pulse. Clocking is accomplished on the low-to-high transition of the clock pulse. The CLOCK-INHIBIT input should be shifted high only while the CLOCK input is held high. A direct clear input overrides all other inputs, including the clock, and sets all the flip-flops to zero. Functional details are shown in the truth table and the timing charts.

All inputs are equipped with protection circuits against static discharge or transient excess voltage.

Features

- High speed: $f_{max} = 170 \text{ MHz (typ.)}$ at $V_{CC} = 5 \text{ V}$
- Low power dissipation: $I_{CC} = 8 \mu\text{A (max)}$ at $T_a = 25^\circ\text{C}$
- High noise immunity: $V_{NIH} = V_{NIL} = 28\% V_{CC} \text{ (min)}$
- Symmetrical output impedance: $|I_{OH}| = I_{OL} = 24 \text{ mA (min)}$
Capability of driving 50Ω transmission lines.
- Balanced propagation delays: $t_{pLH} \approx t_{pHL}$
- Wide operating voltage range: $V_{CC} \text{ (opr)} = 2 \text{ to } 5.5 \text{ V}$
- Pin and function compatible with 74HC166

Pin Assignment

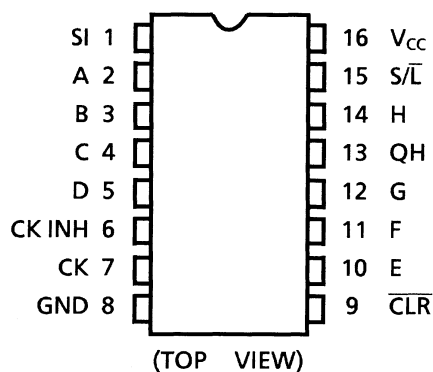

Note: xxxFN (JEDEC SOP) is not available in Japan.

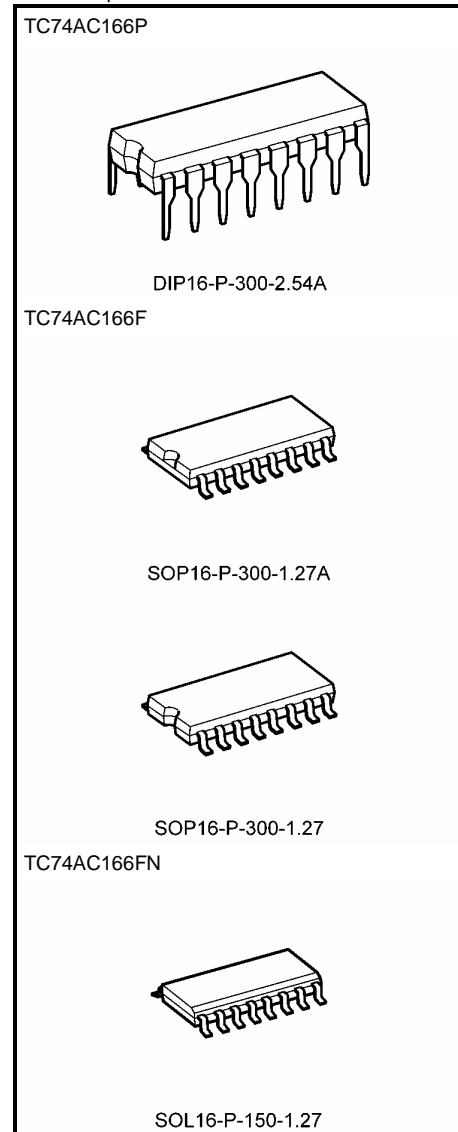

Weight	
DIP16-P-300-2.54A	: 1.00 g (typ.)
SOP16-P-300-1.27A	: 0.18 g (typ.)
SOP16-P-300-1.27	: 0.18 g (typ.)
SOL16-P-150-1.27	: 0.13 g (typ.)

IEC Logic Symbol

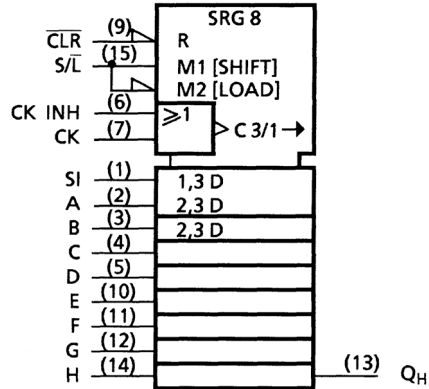

Truth Table

Inputs						Internal Output		Output
$\overline{\text{CLR}}$	SHIFT/LOAD	CK INH.	CK	SERIAL IN	PARALLEL A.....H	QA	QB	QH
L	X	X	X	X	X	L	L	L
H	X	X	\downarrow	X	X	No Change		
H	L	L	\uparrow	X	a.....h	a	b	h
H	H	L	\uparrow	H	X	H QAn		QGn
H	H	L	\uparrow	L	X	L QAn		QGn
H	X	H	X	X	X	No Change		

X: Don't care

a.....h: The level of steady state input voltage at inputs A through H respectively

Timing Chart

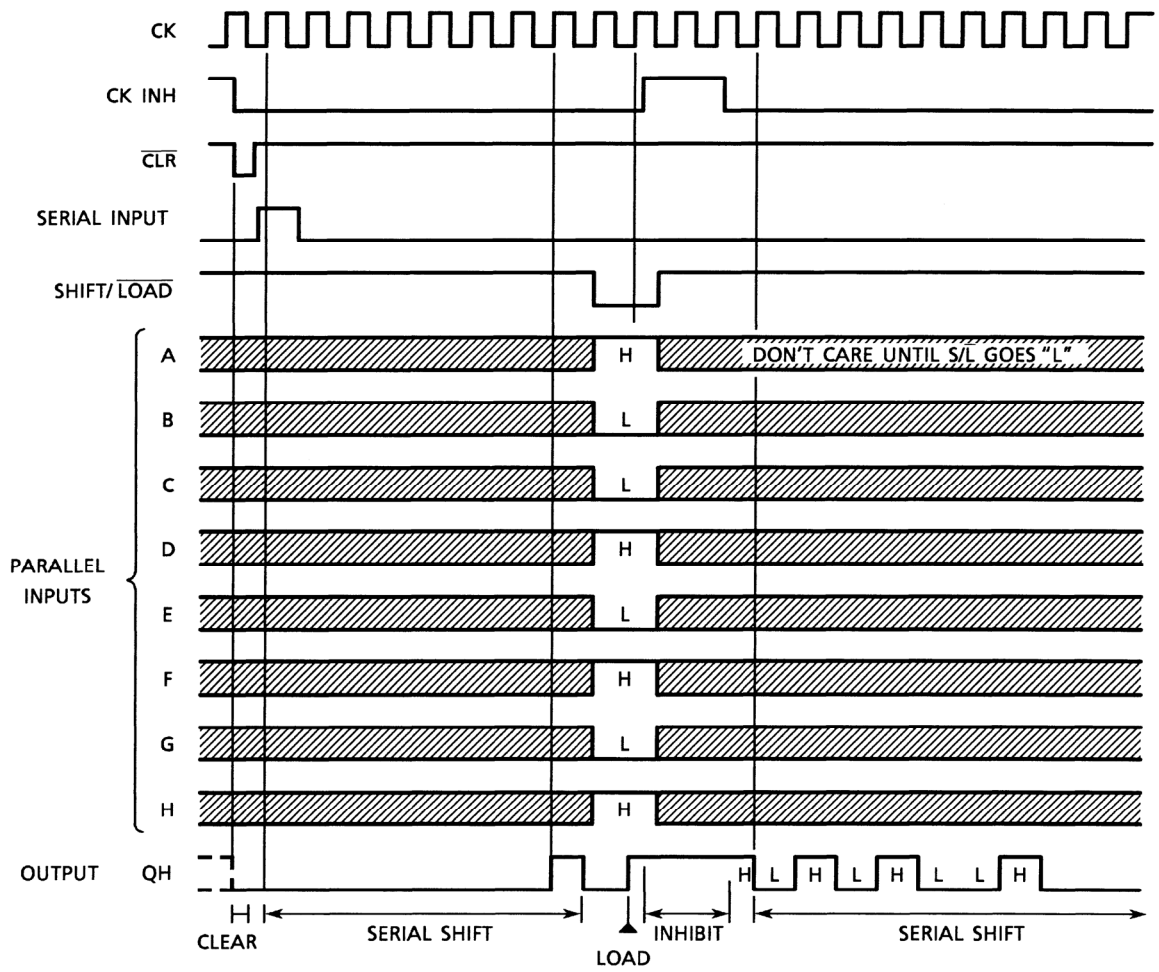

System Diagram

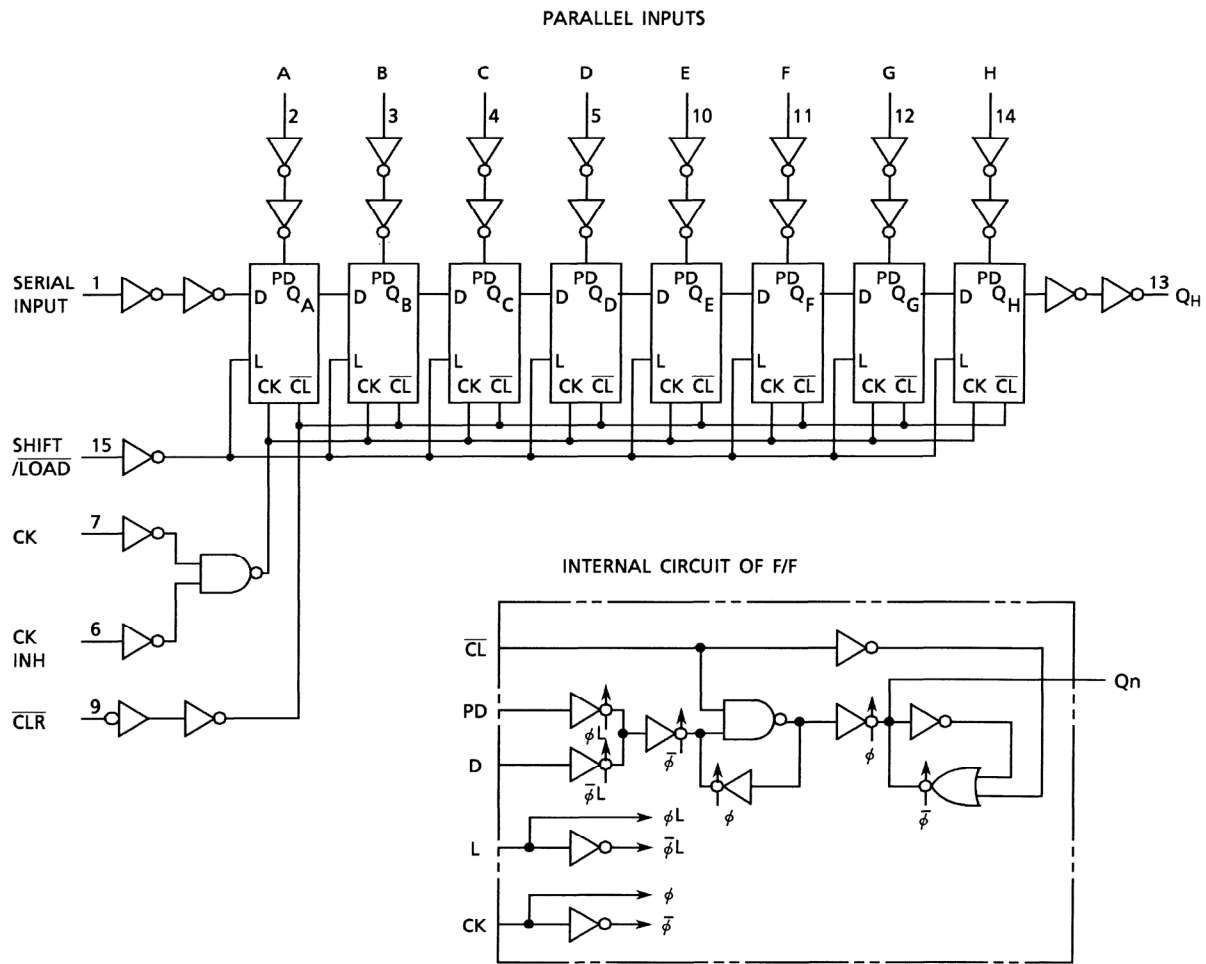

Absolute Maximum Ratings (Note 1)

Characteristics	Symbol	Rating	Unit
Supply voltage range	V_{CC}	-0.5 to 7.0	V
DC input voltage	V_{IN}	-0.5 to $V_{CC} + 0.5$	V
DC output voltage	V_{OUT}	-0.5 to $V_{CC} + 0.5$	V
Input diode current	I_{IK}	± 20	mA
Output diode current	I_{OK}	± 50	mA
DC output current	I_{OUT}	± 50	mA
DC V_{CC} /ground current	I_{CC}	± 100	mA
Power dissipation	P_D	500 (DIP) (Note 2)/180 (SOP)	mW
Storage temperature	T_{stg}	-65 to 150	$^{\circ}C$

Note1: Exceeding any of the absolute maximum ratings, even briefly, lead to deterioration in IC performance or even destruction.

Note2: 500 mW in the range of $T_a = -40$ to $65^{\circ}C$. From $T_a = 65$ to $85^{\circ}C$ a derating factor of -10 mW/ $^{\circ}C$ should be applied up to 300 mW.

Recommended Operating Conditions (Note)

Characteristics	Symbol	Rating	Unit
Supply voltage	V_{CC}	2.0 to 5.5	V
Input voltage	V_{IN}	0 to V_{CC}	V
Output voltage	V_{OUT}	0 to V_{CC}	V
Operating temperature	T_{opr}	-40 to 85	°C
Input rise and fall time	dt/dV	0 to 100 ($V_{CC} = 3.3 \pm 0.3$ V) 0 to 20 ($V_{CC} = 5 \pm 0.5$ V)	ns/V

Note: The recommended operating conditions are required to ensure the normal operation of the device. Unused inputs must be tied to either VCC or GND.

Electrical Characteristics

DC Characteristics

Characteristics	Symbol	Test Condition	$T_a = 25^\circ\text{C}$			$T_a = -40$ to 85°C		Unit		
			V_{CC} (V)	Min	Typ.	Max	Min		Max	
High-level input voltage	V_{IH}	—	2.0	1.50	—	—	1.50	—	V	
			3.0	2.10	—	—	2.10	—		
			5.5	3.85	—	—	3.85	—		
Low-level input voltage	V_{IL}	—	2.0	—	—	0.50	—	0.50	V	
			3.0	—	—	0.90	—	0.90		
			5.5	—	—	1.65	—	1.65		
High-level output voltage	V_{OH}	$V_{IN} = V_{IH}$ or V_{IL}	$I_{OH} = -50 \mu\text{A}$	2.0	1.9	2.0	—	1.9	—	V
				3.0	2.9	3.0	—	2.9	—	
				4.5	4.4	4.5	—	4.4	—	
				5.5	—	—	—	—	—	
Low-level output voltage	V_{OL}	$V_{IN} = V_{IH}$ or V_{IL}	$I_{OL} = 50 \mu\text{A}$	2.0	—	0.0	0.1	—	0.1	V
				3.0	—	0.0	0.1	—	0.1	
				4.5	—	0.0	0.1	—	0.1	
				5.5	—	—	—	—	—	
Low-level output voltage	V_{OL}	$V_{IN} = V_{IH}$ or V_{IL}	$I_{OL} = 12 \text{ mA}$	3.0	—	—	0.36	—	0.44	V
				4.5	—	—	0.36	—	0.44	
				5.5	—	—	—	—	1.65	
				5.5	—	—	—	—	—	
Input leakage current	I_{IN}	$V_{IN} = V_{CC}$ or GND	5.5	—	—	± 0.1	—	± 1.0	μA	
			5.5	—	—	8.0	—	80.0	μA	

Note: This spec indicates the capability of driving 50 Ω transmission lines.
One output should be tested at a time for a 10 ms maximum duration.

Timing Requirements (input: $t_r = t_f = 3 \text{ ns}$)

Characteristics	Symbol	Test Condition	V _{CC} (V)	Ta = 25°C	Ta = -40 to 85°C	Unit
				Limit	Limit	
Minimum pulse width (CK)	t_W (H)	—	3.3 ± 0.3	7.0	7.0	ns
	t_W (L)	—	5.0 ± 0.5	5.0	5.0	
Minimum pulse width ($\overline{\text{CLR}}$)	t_W (L)	—	3.3 ± 0.3 5.0 ± 0.5	8.0 5.0	8.0 5.0	ns
Minimum set-up time (SI, PI)	t_s	—	3.3 ± 0.3	8.0	8.0	ns
			5.0 ± 0.5	4.0	4.0	
Minimum set-up time (S/\overline{L})	t_s	—	3.3 ± 0.3	7.0	7.0	ns
			5.0 ± 0.5	4.0	4.0	
Minimum hold time (SI, PI)	t_h	—	3.3 ± 0.3	0.5	0.5	ns
			5.0 ± 0.5	0.5	0.5	
Minimum hold time (S/\overline{L})	t_h	—	3.3 ± 0.3	1.0	1.0	ns
			5.0 ± 0.5	1.0	1.0	
Minimum removal time ($\overline{\text{CLR}}$)	t_{rem}	—	3.3 ± 0.3	4.0	4.0	ns
			5.0 ± 0.5	1.5	1.5	

AC Characteristics ($C_L = 50 \text{ pF}$, $R_L = 500 \Omega$, input: $t_r = t_f = 3 \text{ ns}$)

Characteristics	Symbol	Test Condition	Ta = 25°C			Ta = -40 to 85°C		Unit	
			V _{CC} (V)	Min	Typ.	Max	Min		Max
Propagation delay time (CK-QH)	t_{pLH} t_{pHL}	—	3.3 ± 0.3	—	9.4	16.1	1.0	18.3	ns
			5.0 ± 0.5	—	6.6	10.0	1.0	11.4	
Propagation delay time ($\overline{\text{CLR}}$ -QH)	t_{pHL}	—	3.3 ± 0.3	—	9.2	15.2	1.0	17.4	ns
			5.0 ± 0.5	—	6.4	9.6	1.0	10.9	
Maximum clock frequency	f_{max}	—	3.3 ± 0.3	55	105	—	55	—	MHz
			5.0 ± 0.5	90	150	—	90	—	
Input capacitance	C_{IN}	—	—	5	10	—	10	pF	
Power dissipation capacitance (Note)	C_{PD}	—	—	67	—	—	—	pF	

Note: C_{PD} is defined as the value of the internal equivalent capacitance which is calculated from the operating current consumption without load.

Average operating current can be obtained by the equation:

$$I_{\text{CC (opr)}} = C_{\text{PD}} \cdot V_{\text{CC}} \cdot f_{\text{IN}} + I_{\text{CC}}$$

Package Dimensions

DIP16-P-300-2.54A

Unit : mm

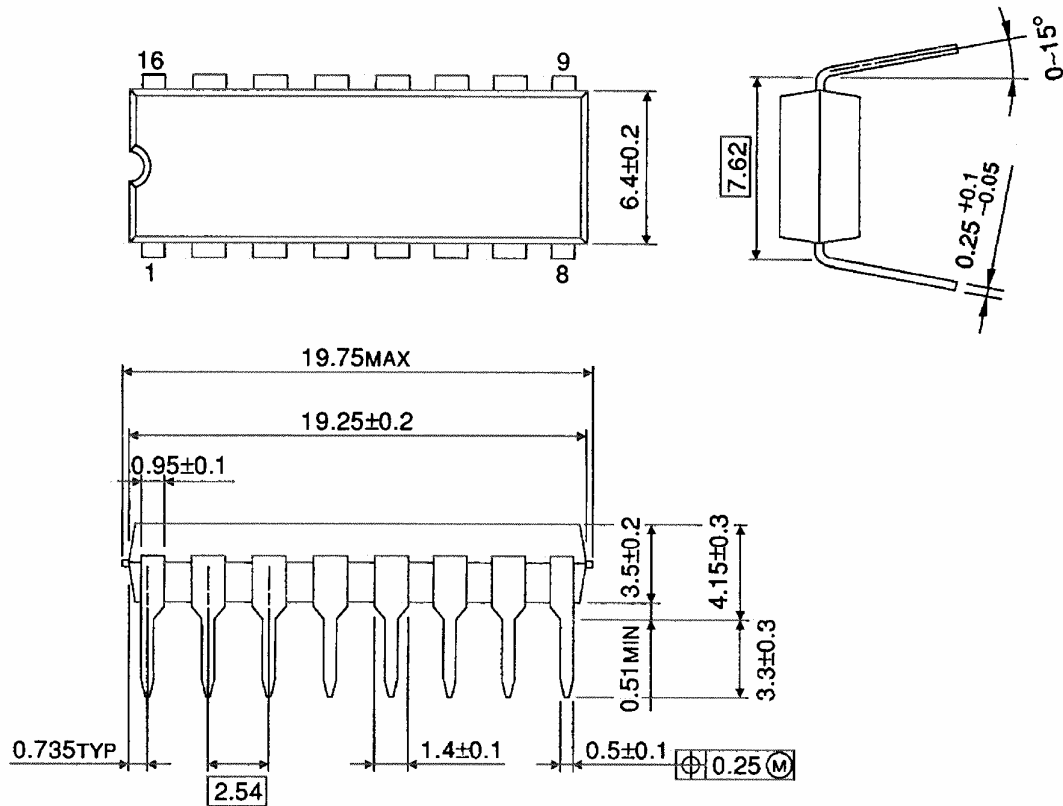

Weight: 1.00 g (typ.)

Package Dimensions

SOP16-P-300-1.27A

Unit: mm

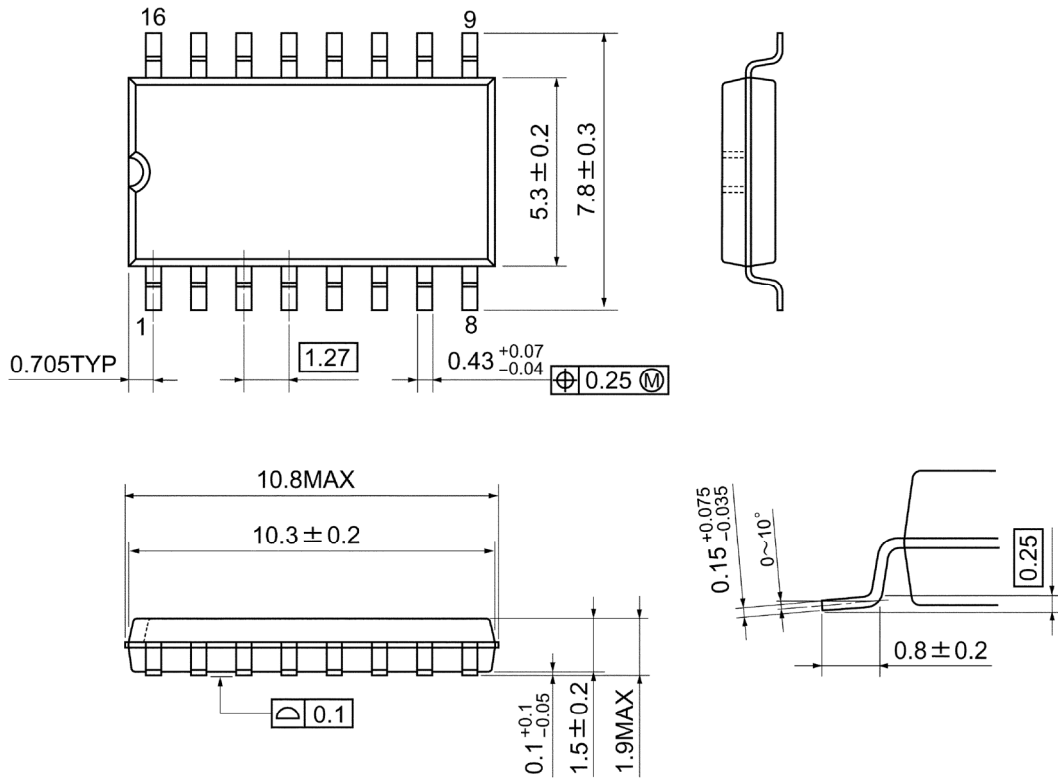

Weight: 0.18 g (typ.)

Package Dimensions

SOP16-P-300-1.27

Unit : mm

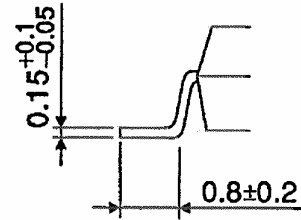
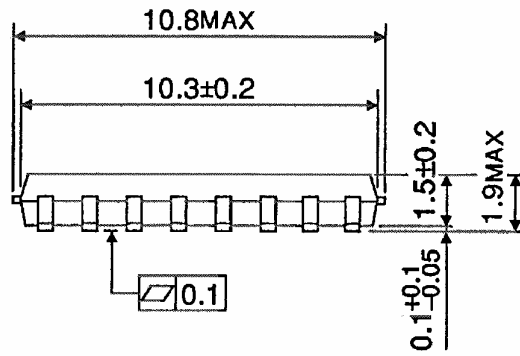
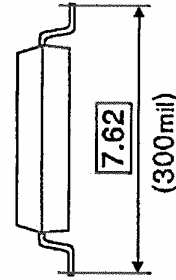
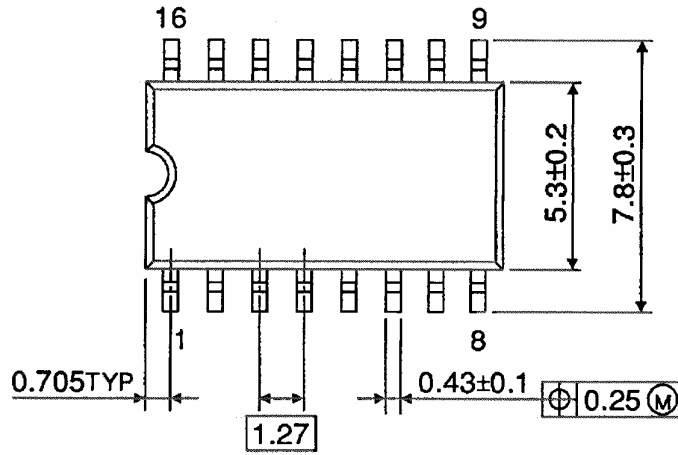

Weight: 0.18 g (typ.)

Package Dimensions (Note)

SOL16-P-150-1.27

Unit : mm

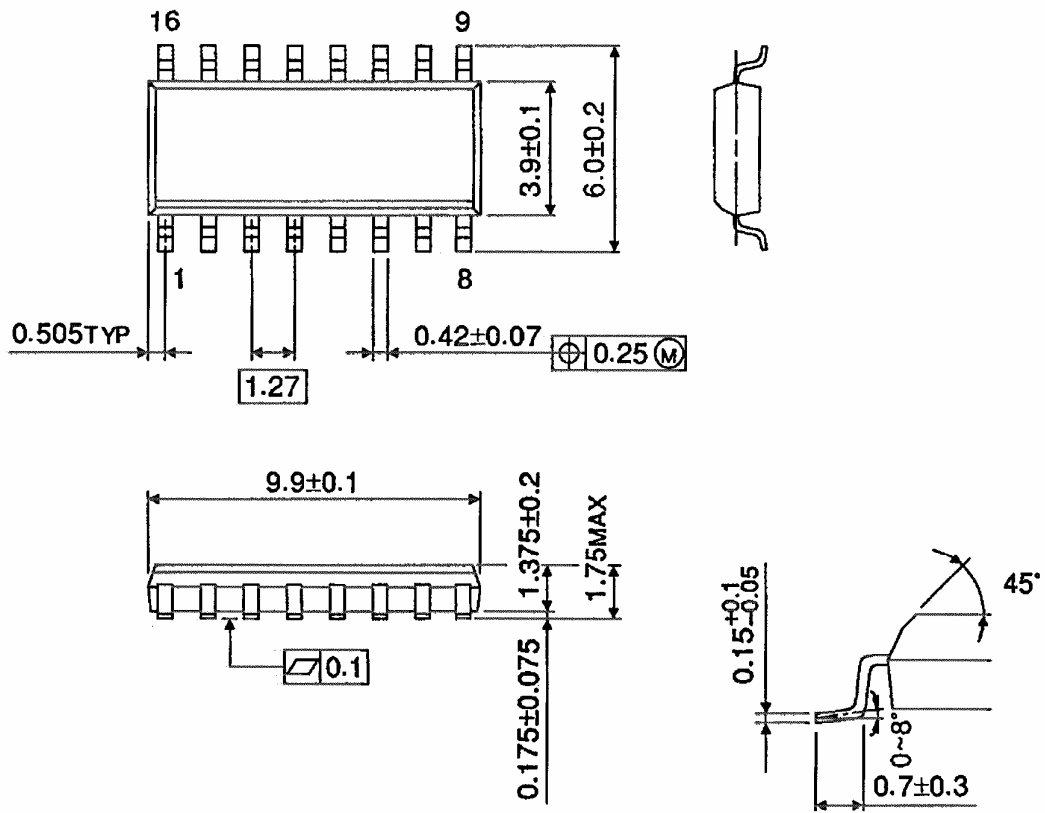

Note: This package is not available in Japan.

Weight: 0.13 g (typ.)

Note: Lead (Pb)-Free Packages**DIP16-P-300-2.54A SOP16-P-300-1.27A SOL16-P-150-1.27****RESTRICTIONS ON PRODUCT USE**

060116EBA

- The information contained herein is subject to change without notice. 021023_D
- TOSHIBA is continually working to improve the quality and reliability of its products. Nevertheless, semiconductor devices in general can malfunction or fail due to their inherent electrical sensitivity and vulnerability to physical stress. It is the responsibility of the buyer, when utilizing TOSHIBA products, to comply with the standards of safety in making a safe design for the entire system, and to avoid situations in which a malfunction or failure of such TOSHIBA products could cause loss of human life, bodily injury or damage to property.
In developing your designs, please ensure that TOSHIBA products are used within specified operating ranges as set forth in the most recent TOSHIBA products specifications. Also, please keep in mind the precautions and conditions set forth in the "Handling Guide for Semiconductor Devices," or "TOSHIBA Semiconductor Reliability Handbook" etc. 021023_A
- The TOSHIBA products listed in this document are intended for usage in general electronics applications (computer, personal equipment, office equipment, measuring equipment, industrial robotics, domestic appliances, etc.). These TOSHIBA products are neither intended nor warranted for usage in equipment that requires extraordinarily high quality and/or reliability or a malfunction or failure of which may cause loss of human life or bodily injury ("Unintended Usage"). Unintended Usage include atomic energy control instruments, airplane or spaceship instruments, transportation instruments, traffic signal instruments, combustion control instruments, medical instruments, all types of safety devices, etc. Unintended Usage of TOSHIBA products listed in this document shall be made at the customer's own risk. 021023_B
- The products described in this document shall not be used or embedded to any downstream products of which manufacture, use and/or sale are prohibited under any applicable laws and regulations. 060106_Q
- The information contained herein is presented only as a guide for the applications of our products. No responsibility is assumed by TOSHIBA for any infringements of patents or other rights of the third parties which may result from its use. No license is granted by implication or otherwise under any patent or patent rights of TOSHIBA or others. 021023_C
- The products described in this document are subject to the foreign exchange and foreign trade laws. 021023_E