

SIEMENS

SIMATIC ET 200BL Distributed I/O system



System Manual

Introduction	1
Safety information	2
Industrial cybersecurity	3
System overview	4
Application planning	5
Installation	6
Wiring	7
Configuring	8
Commissioning	9
Maintenance	10
Technical specifications	11
Dimension drawings	A
Accessories/spare parts	B
Calculating the leakage resistance	C

Legal information

Warning notice system

This manual contains notices you have to observe in order to ensure your personal safety, as well as to prevent damage to property. The notices referring to your personal safety are highlighted in the manual by a safety alert symbol, notices referring only to property damage have no safety alert symbol. These notices shown below are graded according to the degree of danger.

 DANGER
indicates that death or severe personal injury will result if proper precautions are not taken.
 WARNING
indicates that death or severe personal injury may result if proper precautions are not taken.
 CAUTION
indicates that minor personal injury can result if proper precautions are not taken.
NOTICE
indicates that property damage can result if proper precautions are not taken.

If more than one degree of danger is present, the warning notice representing the highest degree of danger will be used. A notice warning of injury to persons with a safety alert symbol may also include a warning relating to property damage.

Qualified Personnel

The product/system described in this documentation may be operated only by **personnel qualified** for the specific task in accordance with the relevant documentation, in particular its warning notices and safety instructions. Qualified persons are those who, because of their training and experience, are familiar with the installation, assembly, commissioning, operation, decommissioning and disassembly of the product and can recognize risks and avoid possible hazards.

Proper use of Siemens products

Note the following:

 WARNING
Siemens products may only be used for the application described in the catalog and the associated usage information. If products and components from other manufacturers are used, these must be recommended or approved by Siemens. Proper transport, storage, installation, assembly, commissioning, operation and maintenance are required to ensure that the products operate safely and without any problems. The permissible ambient conditions must be complied with. The information in the relevant documentation must be observed.

Trademarks

All names identified by ® are registered trademarks of Siemens Aktiengesellschaft. The remaining trademarks in this publication may be trademarks whose use by third parties for their own purposes could violate the rights of the owner.

Disclaimer of Liability

We have reviewed the contents of this publication to ensure consistency with the hardware and software described. Since variance cannot be precluded entirely, we cannot guarantee full consistency. However, the information in this publication is reviewed regularly and any necessary corrections are included in subsequent editions.

Table of contents

1	Introduction.....	7
1.1	Introduction.....	7
1.2	Siemens Industry Online Support.....	8
1.3	SiePortal.....	8
1.4	ET 200BL Documentation Guide.....	9
1.4.1	Tool support.....	10
1.4.2	MultiFieldbus Configuration Tool (MFCT).....	10
1.4.3	SIMATIC Technical Documentation.....	12
2	Safety information.....	14
2.1	Warnings in this document.....	14
2.2	Safety-related symbols.....	14
2.2.1	Devices without explosion protection.....	14
2.3	Intended use.....	15
2.4	Changes to the device and spare parts.....	15
2.5	Target group and personnel qualifications.....	16
2.6	Personal protective equipment.....	16
2.7	Safe working.....	17
2.7.1	Working on electrical parts.....	17
2.8	Residual risks.....	18
2.8.1	Live parts.....	18
2.8.2	External power supply to modules.....	19
2.8.3	Voltage dangerous to touch due to permissible electric potential difference.....	19
2.8.4	Conductive pollution.....	19
2.8.5	Overheating.....	20
2.8.6	Uncontrolled movements.....	20
2.8.7	Unsafe operating states.....	20
2.9	Behavior in case of emergency.....	21
2.10	Material damage.....	21
2.10.1	Transport and storage.....	21
2.10.2	Installation and connection.....	21
3	Industrial cybersecurity.....	22
3.1	Cybersecurity information.....	22
3.2	Security update notification.....	23
3.3	Basic information on industrial cybersecurity.....	23
3.3.1	Definition of industrial cybersecurity.....	23

3.3.2	Objectives of industrial cybersecurity.....	24
3.4	Integrated security concept and security strategies.....	24
3.4.1	Comprehensive security concept "Defense in Depth".....	24
3.4.2	Security management.....	25
3.5	Operational application environment and security assumptions.....	27
3.5.1	Intended use.....	27
3.5.2	Requirements for the operational application environment and security assumptions.....	28
3.6	Security properties of the devices.....	29
3.7	Secure operation of the system.....	29
3.7.1	Introduction to secure operation of the system.....	29
3.7.2	Hardening measures.....	29
3.7.3	Secure configuration.....	30
3.7.4	Access control.....	30
3.7.5	Handling of sensitive data.....	30
3.7.6	Regular firmware updates.....	31
3.7.7	Notifications about security vulnerabilities (Siemens Security Advisories).....	31
3.7.8	Data backup.....	32
3.7.9	Security checks.....	32
3.7.10	Secure decommissioning.....	32
3.7.10.1	Introduction.....	32
3.7.10.2	Securely removing data.....	33
3.7.10.3	Recycling and disposal.....	34
3.8	Secure operation of the engineering software.....	34
3.9	Secure operation of interface modules.....	34
3.9.1	Signed firmware update for interface modules.....	34
3.9.2	Secure Boot for interface modules.....	36
3.10	Secure operation of I/O modules.....	36
4	System overview.....	37
4.1	What is the SIMATIC ET 200BL distributed I/O system?.....	37
4.2	Components.....	39
5	Application planning.....	41
5.1	Hardware configuration.....	41
5.2	Forming potential groups.....	41
6	Installation.....	43
6.1	Basics.....	43
6.2	Installing/removing an interface module.....	47
6.3	Installing/removing I/O modules.....	50
6.4	Installing/uninstalling the end cover.....	52

7	Wiring	54
7.1	Rules and regulations for operation	54
7.2	Operation of ET 200BL on grounded infeed	56
7.3	Electrical configuration of the ET 200BL	59
7.4	Wiring rules	60
7.5	Wiring I/O modules	62
7.6	Connecting supply voltage on the interface module	64
7.7	Connecting interfaces for communication	65
7.8	Labeling the ET 200BL	66
7.8.1	Factory markings	66
7.8.2	Optional markings	68
7.8.3	Applying color identification labels	70
7.8.4	Applying labeling strips	71
7.8.5	Applying reference identification labels	72
8	Configuring	73
8.1	Configuring ET 200BL	73
8.2	Configuring the interface module	74
8.3	Substitute value behavior	74
9	Commissioning	75
9.1	Overview	75
9.2	Commissioning ET 200BL on PROFINET IO	76
9.2.1	ET 200BL as IO device	76
9.3	Identification and maintenance data	77
9.3.1	Reading out and entering I&M data	77
9.3.2	Data record structure for I&M data	79
10	Maintenance	81
10.1	Removing and inserting I/O modules	81
10.2	Exchanging the terminal block	82
10.3	Firmware update	84
10.4	Resetting interface module (PROFINET IO) to factory settings	87
10.5	Maintenance and repair	88
10.6	Warranty	89

11	Technical specifications.....	90
11.1	Introduction.....	90
11.2	Safety information.....	90
11.3	Marks and approvals.....	91
11.4	Standards and requirements.....	92
11.5	Electromagnetic compatibility.....	95
11.6	Shipping and storage conditions.....	97
11.7	Mechanical and climatic environmental conditions.....	97
11.8	Insulation, protection class, degree of protection and rated voltage.....	99
A	Dimension drawings.....	101
A.1	Labeling strip.....	101
A.2	Reference identification labels.....	102
B	Accessories/spare parts.....	103
C	Calculating the leakage resistance.....	105
	Glossary.....	106
	Index.....	112

Introduction

1.1 Introduction

Purpose of the documentation

This documentation provides important information on configuring, installing, wiring and commissioning the ET 200BL distributed I/O system.

Basic knowledge required

A basic knowledge of automation technology is required to understand the documentation.

Validity of the documentation

This documentation applies to the distributed I/O system, ET 200BL.

Conventions

Please pay particular attention to notes highlighted as follows:

NOTE

Notes contain important information on the product, handling the product or on part of the documentation to which you should pay particular attention.

ID link for the digital nameplate



The ID Link is a globally unique identifier according to IEC 61406, which you will find in the future as a QR code on your product.

The figure shows an example of an ID link for the digital input module DI 16x24 VDC.

You can recognize the ID link by the frame with a black frame corner at the bottom right. The ID link takes you to the digital nameplate of your product.

Scan the QR code on the product or on the packaging label with a smartphone camera, barcode scanner or reader app. Call the ID link.

In the digital nameplate, you will find product data, manuals, declarations of conformity, certificates and other helpful information about your product.

Standards

You can find a dated reference to the respective standards or the EU Declaration of Conformity on the Internet (<https://sieportal.siemens.com/su/blGul>).

1.2 Siemens Industry Online Support

You can find current information on the following topics quickly and easily here:

- **Product support**

All the information and extensive know-how on your product, technical specifications, FAQs, certificates, downloads, and manuals.

- **Application examples**

Tools and examples to solve your automation tasks – as well as function blocks, performance information and videos.

- **Services**

Information about Industry Services, Field Services, Technical Support, spare parts and training offers.

- **Forums**

For answers and solutions concerning automation technology.

- **mySupport**

Your personal working area in Industry Online Support for messages, support queries, and configurable documents.

This information is provided by the Siemens Industry Online Support in the Internet (<https://support.industry.siemens.com>).

1.3 SiePortal

SiePortal is the catalog and ordering system of Siemens AG for automation and drive solutions on the basis of Totally Integrated Automation (TIA) and Totally Integrated Power (TIP).

You can find catalogs for all automation and drive products on the Internet (<https://mall.industry.siemens.com>).

1.4 ET 200BL Documentation Guide



The documentation for the SIMATIC ET 200BL distributed I/O system is arranged into three areas.

This arrangement enables you to access the specific content you require.

You can download the documentation free of charge from the Internet (<https://support.industry.siemens.com/cs/de/en/view/109987785>).

Basic information



The System Manual describes in detail the configuration, installation, wiring and commissioning of the SIMATIC ET 200BL distributed I/O system.

The online help of STEP 7 (TIA Portal) and STEP 7 MicroWIN support you during configuration and programming.

Examples:

- ET 200BL System Manual
- Online help TIA Portal
- STEP 7 MicroWIN online help

Device information



Equipment manuals contain a compact description of the module-specific information, such as properties, wiring diagrams, characteristics and technical specifications.

Examples:

- Equipment Manuals Interface Modules
- Equipment Manuals Digital Modules
- Equipment Manuals Analog Modules

General information



The function manuals contain detailed descriptions on general topics relating to the SIMATIC ET 200BL distributed I/O system.

Examples:

- Function Manual Diagnostics
- Function Manual Communication
- PROFINET Function Manual
- Function Manual Designing Interference-free Controllers

Manual Collection ET 200BL

The Manual Collection contains the complete documentation on the SIMATIC ET 200BL distributed I/O system gathered together in one file.

You can find the Manual Collection on the Internet.

(<https://support.automation.siemens.com/WW/view/en/109987784>)

1.4.1 Tool support

Tools

The tools described below support you in all steps: from planning, over commissioning, all the way to analysis of your system.

TIA Selection Tool

The TIA Selection Tool tool supports you in the selection, configuration, and ordering of devices for Totally Integrated Automation (TIA).

As successor of the SIMATIC Selection Tools , the TIA Selection Tool assembles the already known configurators for automation technology into a single tool.

With the TIA Selection Tool , you can generate a complete order list from your product selection or product configuration.

You can find the TIA Selection Tool on the Internet.

(<https://support.industry.siemens.com/cs/ww/en/view/109767888>)

1.4.2 MultiFieldbus Configuration Tool (MFCT)

MultiFieldbus Configuration Tool

MultiFieldbus Configuration Tool (MFCT) is a PC-based software and supports the configuration of MultiFieldbus- and DALI-devices. In addition, the MFCT offers convenient options for mass firmware updates of ET 200 devices with MultiFieldbus- support and reading service data for many other Siemens devices.

Functional scope of the MFCT

- MultiFieldbus configuration:
Engineering, configuration and diagnostics of MultiFieldbus-devices, provision of the required project files (project, UDT-, CSV- and EDS-file), transfer/export of the files to device and/or data memory.
- DALI configuration:
Device selection and online configuration of DALI devices.
- TM FAST:
Generation and download of FPGA-UPD- and FPGA-DB-files.

- Maintenance:
Topology scan of a Ethernet network, reading of service data, parameter assignment and firmware update.
- Settings:
Language switching German / English, network scanner speed, setting of the network adapter, installation of GSDML-and EDS-files.

System/installation requirements for MFCT

The MFCT runs under Microsoft Windows and does not require installation or administrator rights.

For MFCT you must also install the following software:

- Microsoft .NET Framework 4.8 (You can find an Offline Installer on the Internet. (<https://support.microsoft.com/en-us/topic/microsoft-net-framework-4-8-offline-installer-for-windows-9d23f658-3b97-68ab-d013-aa3c3e7495e0>))
- NPcap from directory "Misc"
- PG/PC interface from directory "Misc"
- Microsoft C++ Redistributable for x86-systems (you can find the installation data for download on the Internet. (https://aka.ms/vs/15/release/vc_redist.x86.exe))

The download of the tool and further information as well as documentation on the individual functions of the MFCT can be found on the Internet.

(<https://support.industry.siemens.com/cs/de/en/view/109773881>)

1.4.3 SIMATIC Technical Documentation

Additional SIMATIC documents will complete your information. You can find these documents and their use at the following links and QR codes.

The Industry Online Support gives you the option to get information on all topics. Application examples support you in solving your automation tasks.

Overview of the SIMATIC Technical Documentation

Here you will find an overview of the SIMATIC documentation available in Siemens Industry Online Support:



Industry Online Support International

(<https://support.industry.siemens.com/cs/ww/en/view/109742705>)

Watch this short video to find out where you can find the overview directly in Siemens Industry Online Support and how to use Siemens Industry Online Support on your mobile device:



Quick introduction to the technical documentation of automation products per video (<https://support.industry.siemens.com/cs/us/en/view/109780491>)



YouTube video: Siemens Automation Products - Technical Documentation at a Glance (<https://youtu.be/TwLSxxRQsA>)

Retention of the documentation

Retain the documentation for later use.

For documentation provided in digital form:

1. Download the associated documentation after receiving your product and before initial installation/commissioning. Use the following download options:
 - Industry Online Support International: (<https://support.industry.siemens.com>)
The article number is used to assign the documentation to the product. The article number is specified on the product and on the packaging label. Products with new, non-compatible functions are provided with a new article number and documentation.
 - ID link:
Your product may have an ID link. The ID link is a QR code with a frame and a black frame corner at the bottom right. The ID link takes you to the digital nameplate of your product. Scan the QR code on the product or on the packaging label with a smartphone camera, barcode scanner, or reader app. Call up the ID link.
2. Retain this version of the documentation.

Updating the documentation

The documentation of the product is updated in digital form. In particular in the case of function extensions, the new performance features are provided in an updated version.

1. Download the current version as described above via the Industry Online Support or the ID link.
2. Also retain this version of the documentation.

mySupport

With "mySupport" you can get the most out of your Industry Online Support.

Registration	You must register once to use the full functionality of "mySupport". After registration, you can create filters, favorites and tabs in your personal workspace.
Support requests	Your data is already filled out in support requests, and you can get an overview of your current requests at any time.
Documentation	In the Documentation area you can build your personal library.
Favorites	You can use the "Add to mySupport favorites" to flag especially interesting or frequently needed content. Under "Favorites", you will find a list of your flagged entries.
Recently viewed articles	The most recently viewed pages in mySupport are available under "Recently viewed articles".
CAX data	The CAX data area gives you access to the latest product data for your CAX or CAE system. You configure your own download package with a few clicks: <ul style="list-style-type: none"> • Product images, 2D dimension drawings, 3D models, internal circuit diagrams, EPLAN macro files • Manuals, characteristics, operating manuals, certificates • Product master data

You can find "mySupport" on the Internet. (<https://support.industry.siemens.com/My/ww/en>)

Application examples

The application examples support you with various tools and examples for solving your automation tasks. Solutions are shown in interplay with multiple components in the system - separated from the focus on individual products.

You can find the application examples on the Internet. (<https://support.industry.siemens.com/cs/ww/en/ps/ae>)

Safety information







2.1 Warnings in this document



You can find explanations of the warnings used in this document in the "Legal information" section.

2.2 Safety-related symbols

2.2.1 Devices without explosion protection

The following table contains an explanation of the symbols located in your SIMATIC device, its packaging or the accompanying documentation.

Symbol	Meaning
	General warning sign Caution/Notice You must read the product documentation. The product documentation contains information about the potential risks and enable you to recognize risks and implement countermeasures.
	Read the information provided by the product documentation. ISO 7010 M002
	Ensure the device is only installed by electrically skilled person. IEC 60417 No. 6182
 CABLE SPEC.	Note that connected mains lines must be designed according to the expected minimum and maximum ambient temperature.
 EMC	Note that the device must be constructed and connected in accordance with EMC regulations.
 230V MODULES	Note that a 230 V device can be exposed to electrical voltages which can be dangerous. ANSI Z535.2

Symbol	Meaning
	Note that a device of Protection Class III may only be supplied with a protective low voltage according to the standard SELV/PELV. IEC 60417-1-5180 "Class III equipment"
	Be aware that the device is only approved for the industrial field and only for indoor use.
	Note that an enclosure is required for installing the device. Enclosures are considered: <ul style="list-style-type: none"> • Standing control cabinet • Serial control cabinet • Terminal boxes • Wall enclosure

2.3 Intended use

The system is used to control machines and plants.

Intended use also includes observance of this documentation, in particular the safety instructions and conditions of use. See Technical specifications ([Page 90](#)) section.

2.4 Changes to the device and spare parts

Modifications to the device can impair the safety and function of the device:

- Do not make any changes or modifications to the device.
- Do not remove or tape over safety instructions on the device.
- Do not tape over, cover or obstruct ventilation slots.
- Only use original spare parts and accessories.

2.5 Target group and personnel qualifications

All persons working with this device require the following knowledge:

- Contents of this document as well as contents of the enclosed documents
- Handling the device (after instruction)
- Relevant standards and regulations
- Accident prevention regulations

The following activities are reserved for specially qualified personnel:

Working on electrical parts

Work on electrical parts may only be performed by the following persons:

- Qualified electricians
- Persons trained in electrical engineering under the direction and supervision of qualified personnel

Commissioning and configuration

Commissioning and configuration requires general knowledge in the field of automation technology.

2.6 Personal protective equipment

The personal protective equipment depends on the activity and is determined by the operator.

To avoid material damage during packing, unpacking and installation activities we recommend:

- ESD wrist strap
- ESD shoes

2.7 Safe working

2.7.1 Working on electrical parts

- Only work on electrical parts if you are a qualified specialist (see section Target group and personnel qualifications [\(Page 16\)](#)).
- Always observe the country-specific safety rules.
- Notify all those who will be affected by the procedure.
- Follow the 5 safety rules according to DIN EN 50110-1 (VDE 0105-1):
 1. Disconnect
 2. Secure to prevent reconnection
 3. Verify safe isolation from the supply (all poles)
 4. Ground and short-circuit
 5. Erect barriers around or cover adjacent live parts

The 5 safety rules must be applied in the above order prior to starting work on an electrical system. After completing the work, proceed in the reverse order.

It is assumed that every electrician is familiar with the 5 rules.

2.8 Residual risks

Despite all the technical and procedural risk reductions that have been carried out, not all dangers can be avoided.

The following sections describe these residual risks and measures to avoid them.

2.8.1 Live parts

Electrocution on contact with live parts leads to life-threatening injuries (death).

Operation

- Do not open the device.
- Never use damaged devices.
- Pull the plug and not the cable.

Installation and connection

- Only work on electrical parts if you are a qualified specialist (see section Target group and personnel qualifications [\(Page 16\)](#)).
- Adhere to the protective measures for safe working on electrical parts (see section Working on electrical parts [\(Page 17\)](#)).
- Fuse the connection cables according to the current-carrying capacity of the cable used, taking into account the applicable standards.
- Install the device in a control cabinet. The enclosures, cabinets or electrical equipment rooms must guarantee protection against electric shock and spread of fire.
- Ground the device in compliance with the applicable regulations.
- For the 24 V DC supply (SELV/PELV), only use power supply units that provide safe electrical extra-low voltage in accordance with IEC 61131-2 or IEC 61010-2-201.

Maintenance

- Only work on electrical parts if you are a qualified specialist (see section Target group and personnel qualifications [\(Page 16\)](#)).
- Adhere to the protective measures for safe working on electrical parts (see section Working on electrical parts [\(Page 17\)](#)).

2.8.2 External power supply to modules

Even if the main supply to the plant is disconnected, externally supplied modules can continue to carry voltage. An electric shock on contact with live parts can lead to death or serious injury.

For special SIMATIC modules, e.g. relay modules, you can connect or switch voltages larger than 24 V DC, e.g. 230 V AC. In some applications, these modules are supplied with voltages from outside the system (external power supply). In the event of an external power supply, a dangerous voltage may still be present on these modules even if the system is disconnected.

Maintenance

Ensure the following points before starting work:

- The plant is completely disconnected from the power supply.
- All externally supplied plant units are disconnected from the power supply

2.8.3 Voltage dangerous to touch due to permissible electric potential difference

Due to the permissible electric potential difference, a dangerous voltage may be present at the inputs of modules. An electric shock on contact with live parts can lead to death or serious injury.

Special SIMATIC modules, such as analog input modules, have isolated channels. In this case, there is no connection between the potential of the sensor and the potential of the module. If a dangerous voltage within the permissible electric potential difference occurs at the sensor, this voltage may also be present at the measurement channel of the module.

You can find the permissible electric potential differences in the technical specifications section of the modules' Equipment Manuals.

Maintenance

Ensure the following points before starting work:

- The plant is completely disconnected from the power supply.
- All externally supplied plant units are disconnected from the power supply

2.8.4 Conductive pollution

Electrocution during transmission of electrical energy via conductive contamination to the body leads to life-threatening injuries (death).

- Install the device in a control cabinet.
- Keep the control cabinet free of conductive contamination.

2.8.5 Overheating

Smoke development and fire due to overheating of the device and cables lead to burns and life-threatening injuries (death).

To avoid overheating:

- Ensure the correct installation position.
- Ensure sufficient air supply (e.g. do not tape over or cover ventilation slots, maintain mounting clearances).
- Only use undamaged cables.

Installation and connection

- Follow the instructions for the mounting position.
- Adhere to the specified ventilation clearances.
- Fuse the connecting cables according to the cable cross-section.

Maintenance

- Check plug-in connections and cables regularly for damage.

2.8.6 Uncontrolled movements

Uncontrolled movements of driven machine or system parts during commissioning, operation, maintenance and repair.

- Follow the safety instructions described in the function manuals.

2.8.7 Unsafe operating states

Unsafe operating states may result in personal injury of unknown extent.

The following factors can be triggers:

- Manipulation of the software, e.g. viruses, trojans or worms

Manipulation of the software, e.g. viruses, trojans or worms

- Adhere to the protective measures against tampering with the software (see section Industrial cybersecurity ([Page 22](#))).
- Perform available updates in a timely manner.
- Protect files stored on removable media from malware with appropriate protective measures, e.g. virus scanner.
- Set up access protection for the CPU.

2.9 Behavior in case of emergency

- Force EMERGENCY OFF

When the safe operating state has been restored:

- Unlock the EMERGENCY OFF mechanism.
- The person responsible for the system ensures that the system starts up in a controlled and defined manner.

2.10 Material damage

2.10.1 Transport and storage

- Only pack, store, transport and ship electronic components, modules or devices in the original product packaging or in other suitable materials, e.g. conductive foam rubber or aluminum foil.
- Observe the limits during transport and storage. See Technical specifications [\(Page 90\)](#) section.

2.10.2 Installation and connection

- We recommend touching components, modules and devices only if they are grounded by one of the following measures:
 - With an ESD wrist strap.
 - With ESD shoes or ESD grounding strips in ESD areas with conductive flooring.
- Place electronic components, modules and devices only on conductive surfaces (e.g. tables with ESD coating, conducting ESD plastic foam, ESD packing bags, ESD transport containers).
- Ensure that there is sufficient overvoltage protection.

Industrial cybersecurity

Due to the digitalization and increasing networking of machines and industrial plants, the risk of cyberattacks is also growing. Appropriate protective measures are therefore mandatory, particularly in the case of critical infrastructure facilities.

In the first part of this section you will find basic information on the subject of industrial cybersecurity. Subsequent sections describe recommended measures for protecting the entire system and individual components from manipulation and unwanted access.

3.1 Cybersecurity information

Siemens provides products and solutions with industrial cybersecurity functions that support the secure operation of plants, systems, machines and networks.

In order to protect plants, systems, machines and networks against cyber threats, it is necessary to implement – and continuously maintain – a holistic, state-of-the-art industrial cybersecurity concept. Siemens' products and solutions constitute one element of such a concept.

Customers are responsible for preventing unauthorized access to their plants, systems, machines and networks. Such systems, machines and components should only be connected to an enterprise network or the internet if and to the extent such a connection is necessary and only when appropriate security measures (e.g. firewalls and/or network segmentation) are in place.

For additional information on industrial cybersecurity measures that may be implemented, please visit <https://www.siemens.com/cybersecurity-industry>.

Siemens' products and solutions undergo continuous development to make them more secure. Siemens strongly recommends that product updates are applied as soon as they are available and that the latest product versions are used. Use of product versions that are no longer supported, and failure to apply the latest updates may increase customer's exposure to cyber threats.

To stay informed about product updates, subscribe to the Siemens Industrial Cybersecurity RSS Feed under <https://new.siemens.com/cert>.

3.2 Security update notification

Observe the special information on maintaining the operational security of your plant in the section Introduction.

Set up notification of security updates

To receive notifications about security updates, proceed as follows:

1. Register on mySiePortal (<https://sieportal.siemens.com/en-ww/home>).
2. Enter the keyword "Security" in the search engine.
3. Choose the "Search in Knowledge base" option.
4. Select your product or product group in the "Product tree" filter menu, e.g. "Automation technology" > "Automation systems" > "SIMATIC industrial automation systems" > "Advanced Controller" > "S7-1500".
5. Select the "Other types" option from the filter menu for "Type," and then choose "Download" and "Product note".
6. Select the document with which you want to create notifications.
For example, if you would like to be informed about all firmware versions of the CPUs, select the entry "Firmware update S7-1500 CPUs incl. displays and ET 200 CPUs (ET 200SP, ET 200pro)".
7. Select "Add to my favorites" using the 3 dots on the right.
8. In the following dialog, enter the name, select the storage location and the "Notify me" option for the favorite. Then click on the "+ Add to my favorites" button.

Result: You will be notified by email each time the document is changed.

Under "mySiePortal" > "Lists & notifications" > "My notifications", you can display your notifications and delete them if necessary.

3.3 Basic information on industrial cybersecurity

3.3.1 Definition of industrial cybersecurity

Industrial cybersecurity is generally understood to mean all measures to protect against the following threats:

- Loss of confidentiality due to unauthorized access to data
- Loss of integrity due to manipulation of data
- Loss of availability (e.g. due to the destruction of data or denial of service (DoS))

3.3.2 Objectives of industrial cybersecurity

The objectives of industrial cybersecurity are:

- Ensuring trouble-free operation of industrial plants and production processes
- Prevention of risks to people and production from cybersecurity attacks
- Protection of industrial plants against espionage and manipulation
- Protection of industrial automation systems and components against unauthorized access and data loss
- Provision of a practical and cost-effective concept for securing existing plants and devices without their own security functions
- Use of existing, open, and proven industrial cybersecurity standards
- Compliance with legal requirements

An optimized and adapted security concept applies to automation and drive technology. The security measures must not impede or endanger production.

3.4 Integrated security concept and security strategies

3.4.1 Comprehensive security concept "Defense in Depth"

With Defense in Depth, Siemens provides a multi-layer security concept that offers industrial plants comprehensive and far-reaching protection in accordance with the recommendations of the IEC 62443 international standard.

Productivity and know-how are protected on 3 levels:

Plant security

Plant security uses various methods to secure the physical access of people to critical components. This starts with classic building access and extends to securing sensitive areas using access control (for example, code card, iris scan, fingerprint or access code).

Network security

Automation networks must be protected against unauthorized access. This is achieved through security measures on the product, but also those in the product-related environment.

System integrity

Targeted measures must be taken to protect existing know-how or prevent unauthorized access to automation processes.

The measures protect against unauthorized configuration changes and identify attempts at manipulation.

You can find more information on the topics of Defense in Depth, plant security, network security, and system integrity on the SIEMENS Industrial cybersecurity

(<https://www.siemens.com/us/en/company/topic-areas/cybersecurity/industrial-security.html>) Web page.

You can also visit the download center (<https://www.siemens.com/us/en/company/topic-areas/cybersecurity/industrial-security/downloads.html>) to obtain more information on the topic of industrial cybersecurity. The "Operational Guidelines", for example, provide

recommendations on basic security measures for secure machine and plant operation in an industrial environment.

3.4.2 Security management

The ISO 27001 and IEC 62443 standards call for a comprehensive approach in information technology (IT) and operational technology (OT) to protect against cyber attacks.

Responsibility for cybersecurity and IT security

Every operator of machinery and equipment is responsible for:

- Establishment of cybersecurity and IT security as an important criterion in the procurement and selection of machines and software applications.
- Use of suitable measures to protect production resources, data, and communication from manipulation and theft
- Provision of all necessary resources and training to employees to fully support these goals

For this purpose, suitable measures must be selected after a risk assessment and a cost-benefit analysis in order to protect material and intellectual property and prevent damage from occurring. These measures should be integrated into corporate processes and procedures, evaluated regularly, and firmly anchored in the corporate culture. In addition to protecting intellectual property, the protection of personal data must be ensured at all organizational units and levels.

Siemens will provide you with information and support. Subscribe to the Security feeds (<https://www.siemens.com/cert>) for information on vulnerabilities. Register on mySiePortal (<https://sieportal.siemens.com/en-ww/home>) and create filters to be notified when important information is published. The procedure is described in the section Notification of security updates. Consider using Siemens Cybersecurity Services.

Responsibility in the digital supply chain

Cybersecurity should play a critical role in the evaluation and procurement process. The entire life cycle of a product should be considered to ensure protection against current and future risks. These include, for example, security updates throughout the product life cycle, including guidelines for secure disposal of the product.

Siemens plans and announces the provision of security updates, as well as total discontinuation of products, as part of product support.

Employee awareness

Regular training in cybersecurity and continuous testing of training success are essential so that cybersecurity measures are internalized in processes and work instructions. This involves general training in the use of software and IT hardware for company communication and as work tools, e.g.:

- secure handling of USB devices
- encrypted communication
- use of VPN
- rules for passwords and use of access
- setting up two-factor authentication
- educating employees about the dangers posed by malware, phishing, social engineering, etc.

Furthermore, if applicable, production equipment and software training should always include the topic of cybersecurity.

Maintaining the security concept through updates

Keeping software up-to-date is essential, for example, to benefit from the following measures:

- Implementation of new security strategies, protocols and techniques
- Closing of security vulnerabilities
- Elimination of security vulnerabilities

To this end, it is necessary to keep a constant eye on the further development of protective measures and, if necessary, the expansion of requirements.

Recommendations:

- Set up notifications for (security) updates
- Subscribe to information on vulnerabilities
- Monitor and implement the further development of the technology, especially in the area of cybersecurity

Always keep technology and knowledge up to date.

Consideration of the risks posed by cyber attacks in the Threat and Risk Assessment (TRA)

Make an inventory of all software, hardware, and infrastructure devices, in order to identify risks to the location or organization. Incident response procedures must be incorporated into all IT and manufacturing processes. The choice of risk mitigation measures should be based on a cost-benefit analysis and classification of risks. This is followed by the introduction of cybersecurity rules and procedures and the training of personnel.

Living the concept

Technical solutions alone are not sufficient to effectively counter threats.

Cybersecurity must be part of the corporate culture and process landscape and must be internalized and lived by all employees.

Continuously monitoring the security situation

You have the following options to monitor the cybersecurity situation continuously:

- Setting anomaly references and creating allow and deny lists based on normal network communication and production machine behavior. The SINEC software family offers you reliable security tools (<https://www.siemens.com/global/en/products/automation/industrial-communication/sinec-network-software/cybersecurity.html>) to detect potential vulnerabilities in OT networks, quickly initiate suitable measures and effectively resolve security vulnerabilities.
- Establishment of an intrusion detection system (IDS) that generates alarms when unusual behavior occurs in the network
- Introduction of a Security Information and Event Management (SIEM) system to collect, analyze, and evaluate events in real time to enable early countermeasures
- Measures regarding network security: e.g. network segmentation, firewalls, VPN, DMZ (demilitarized zones)

3.5 Operational application environment and security assumptions

3.5.1 Intended use

SIMATIC products are intended for use in industry. If you plan to use the product in a different environment, check the conditions required for such use.

The product may be operated only by personnel qualified for the specific task in accordance with the relevant documentation, in particular its warning notices and safety information. Qualified personnel are those who, based on their training and experience, are capable of identifying risks and avoiding potential hazards when working with these products.

Operational reliability and intended use

Observe the "Special information" section in Introduction.

Area of application

Observe the "Area of application" section in System overview.

3.5.2 Requirements for the operational application environment and security assumptions

Siemens recommends the following security measures:

- Threat and Risk Assessments (as part of security management)
- Network security concepts
 - Network segmentation
 - Asset and network management
 - Network protection
 - Remote access
- Access control concepts (utilizing access control systems)
 - Physical protection
 - Physical enterprise security
 - Physical product security

Threat and Risk Assessment

Vulnerabilities and risks are identified, and countermeasures are proposed to ensure the security of the system, networks, and data.

Network security concepts

You can find information on network security in the white paper "Industrial Network Security Architecture", available from the Download Center (<https://www.siemens.com/us/en/company/topic-areas/cybersecurity/industrial-security/downloads.html>) on the Industrial Cybersecurity (<https://www.siemens.com/us/en/company/topic-areas/cybersecurity/industrial-security.html>) website.

Access control concepts

Physical protection

In addition to closing off and/or monitoring entire production facilities, it may be necessary to physically secure cabinets or even individual components such as circuit breakers.

Physical enterprise security

You can ensure physical corporate security by the following measures, among others:

- Closed off and monitored company premises
- Access control, locks/card readers, and/or security personnel
- Accompaniment of non-employees by company personnel
- Employees are trained on and embrace security processes within the company

Physical production security

You can ensure physical production security by the following measures, among others:

- Separate access control for critical areas, such as production areas.
- Installation of critical components in lockable cabinets/control rooms with monitoring and alarm capabilities. The cabinets/control rooms must be secured with a cylinder lock. Do not use simple locks, such as universal, triangular/square, or double-bit locks.
- Radio field planning to limit WLAN coverage areas, preventing them from extending beyond defined zones (e.g. factory floor).
- Guidelines that prohibit the use of external, insecure data storage media (such as USB flash drives) and IT devices (such as laptops) on systems.

3.6 Security properties of the devices

The security properties of the individual devices are listed in the Equipment Manuals.

3.7 Secure operation of the system

3.7.1 Introduction to secure operation of the system

This section describes measures recommended by Siemens to protect your system from manipulation and unauthorized access.

3.7.2 Hardening measures

System hardening, also referred to simply as hardening, is the secure configuration of products or systems. The aim is to close vulnerabilities and take various measures to reduce the attack surfaces for cyberattacks.

Measures for system hardening include, for example:

- Secure configuration in which only software components and services actually needed for operation are installed or activated.
- Access control in which restrictive user and rights management system is implemented.

3.7.3 Secure configuration

Secure configuration involves control over all software components, along with their interfaces, ports, and services.

Activated services and ports pose a risk, for example of unauthorized access to the network and to programs.

To minimize the risk, activate solely the required services at all the automation components. Take into account all activated services (especially web servers, FTP, remote maintenance etc.) in the security concept. Consider the default states of ports and services in your security concept.

You can find an overview of all ports and services used in the Communication Function Manual (<https://support.industry.siemens.com/cs/ww/en/view/59192925>).

3.7.4 Access control

In addition to physical protection, also establish logical safeguards to control access to your system:

- Use a restrictive user and rights management system, e.g. for accessing the CPUs and TIA Portal
- Observe the information regarding password management in the section Protection and in the STEP 7 online help (TIA Portal).

3.7.5 Handling of sensitive data

Data protection information

Siemens Aktiengesellschaft observes the applicable data protection laws, including the General Data Protection Regulation (GDPR), in particular the rules of data minimization and data-protection-friendly default settings (privacy by design, privacy by default).

This means for the products in this system:

Products with user management save user names and passwords to manage access rights. User names are also saved in logging alarms. These logging alarms are provided with a time stamp and stored in the internal cache of the CPU. They can be forwarded to a central syslog server.

You can find more information in the section Syslog messages.

In addition, the products do not store any personal data.

If you establish a reference to an identifiable person by linking these data with other data (for example shift schedules), or if you store personal data on the same medium (for example a hard disk), you must yourself ensure that the data protection regulations are observed.

Information on the secure removal of data from the CPU, interface module, and SIMATIC Memory Card is provided in the section Secure decommissioning.

Storage of security-related data

When storing your security-relevant data on your PC, independently ensure secure data storage.

Observe also the section Data worth protecting.

3.7.6 Regular firmware updates

NOTE

Outdated firmware versions might not be monitored for security vulnerabilities.

- Always keep your plant/products up to date to benefit from bug fixes and to minimize potential risks.
 - Use email notifications to be automatically informed about firmware updates.
-

For more information, refer to:

- The section Firmware update ([Page 84](#))
- The section Notification of security updates ([Page 23](#))

3.7.7 Notifications about security vulnerabilities (Siemens Security Advisories)

A vulnerability is a security vulnerability in information security. It can pose a threat as it provides intruders with the opportunity to access system resources and manipulate or steal data. Many vulnerabilities allow availability to be impaired.

Siemens ProductCERT

When Siemens identifies Vulnerabilities in their products, this is published in Security Advisories.

You can find the documents for SIMATIC on the following Siemens AG Web page: Siemens ProductCERT and Siemens CERT
(<https://new.siemens.com/global/en/products/services/cert.html?s=SIMATIC#SecurityPublications>)

"SIMATIC" is the default in the "Search Security Advisories" search field. You can also enter other product names or other terms in the search field and search for them.

On this page, you will also find all necessary information on handling vulnerabilities:

- Contact persons for matters related to vulnerabilities
- Options for automated notifications regarding vulnerabilities
- Notifications are also possible in CSAF format
- Option to subscribe to RSS feeds and newsletters

3.7 Secure operation of the system

- List of all current vulnerabilities and detailed information such as:
 - Description
 - Score according to Common Vulnerability Scoring System (CVSS)
 - Measures
 - Availability
 - Etc.

Set up Security feeds (<https://www.siemens.com/cert>) to receive notifications about security-related topics.

If you suspect or have discovered a vulnerability in a Siemens product, please inform us immediately. To do this, press the "Contact" button on the CERT Services page (<https://www.siemens.com/cert>) and follow the instructions.

3.7.8 Data backup

Secure your configuration and parameter settings so that you can quickly restore this data if needed.

3.7.9 Security checks

Security checks for data, files and archives serve to protect data integrity at the storage location and during file transfer from manipulation and transmission errors. This is often achieved using digital checksums that are provided alongside the data. Tools (such as SHA-256 or SHA-512) for calculating and verifying these checksums are provided in many systems and named according to their respective calculation methods.

File Integrity Guidelines describe the prescribed procedure for integrity checks.

Integrity protection is a protection function for engineering data and firmware files.

Communication integrity means protecting communication against unauthorized manipulations to ensure high system availability. A central element in this regard is, for example, the use of digital checksums when accessing controllers. (Source: Industrial Cybersecurity website (<https://www.siemens.com/us/en/company/topic-areas/cybersecurity/industrial-security.html>))

3.7.10 Secure decommissioning

3.7.10.1 Introduction

In the following section, you will find information on how to properly decommission individual components of your automation system. Decommissioning is necessary when the component has reached the end of its service life.

Decommissioning includes environmentally sound disposal and secure removal of all digital data of electronic components with storage medium.

3.7.10.2 Securely removing data

Before disposing of components of your automation system, you should securely delete all data from the storage media of these components. How to securely delete data from the devices so that it cannot be recovered is described below.

NOTICE

Data misuse resulting from non-secure deletion of data

Incomplete or non-secure deletion of data from data memories can result in data misuse by third parties.

For this reason, ensure secure deletion of data from all storage media used before disposing of the product.

Secure erasure of data from the interface module

With the following tools, you can securely erase the data from the interface module:

- STEP 7 < V19
- SIMATIC Automation Tool
- MultiFieldbus Configuration Tool (MFCT)
- PRONETA

Follow these steps in the order given:

1. Establish an online connection.
2. Open the Online and Diagnostics view of the IM (either from the project context or via "Accessible devices").
3. In the dialog box "Functions > Reset to factory settings", select the option "Delete I&M data" and then the "Reset" button.

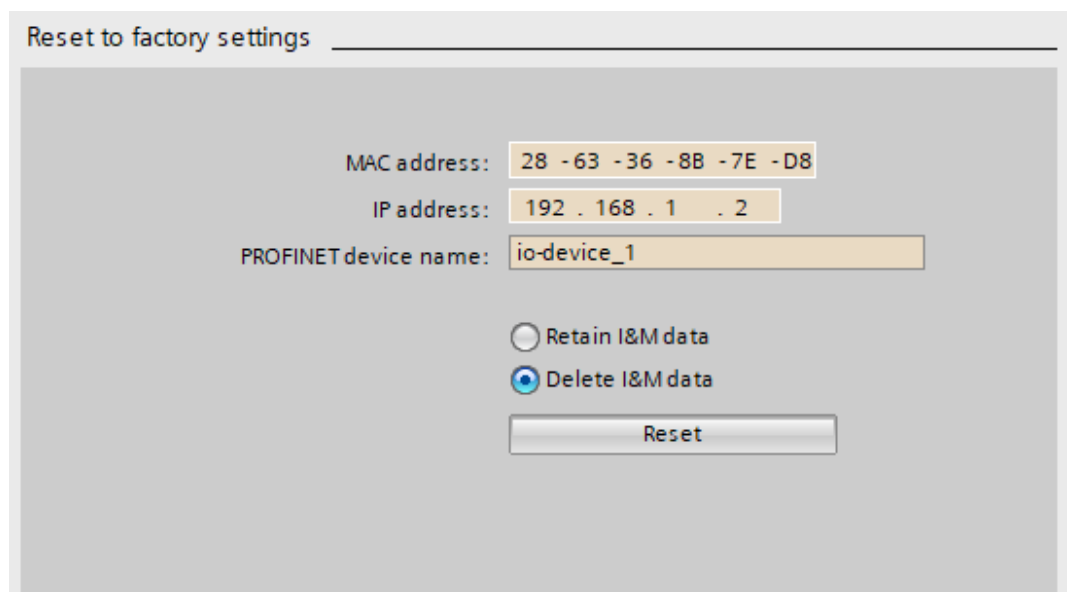

Figure 3-1 Resetting an interface module to factory settings

3.9 Secure operation of interface modules

Result: All the data that was still in the data memories of the interface module was deleted. You can now dispose of the components.

For more information on resetting the interface module to factory settings, refer to the section Resetting an interface module to factory settings.

NOTE

STEP 7 ≥ V19

Only the communication parameters will be securely deleted for "Reset to factory settings" with the "Delete I&M data" option enabled when you use STEP 7 ≥ V19.

Deleted communication parameters:

- IP address
- Device name
- PROFINET configuration data

If you want to securely remove all data, use one of the tools listed above for this purpose.

3.7.10.3 Recycling and disposal

For environmentally sustainable recycling and disposal of your old equipment, contact a certified electronic waste disposal service and dispose of the equipment according to the applicable regulations in your country.

3.8 Secure operation of the engineering software

For more information on secure operation of the engineering software, refer to the TIA Portal online help.

3.9 Secure operation of interface modules

Device-specific security information and instructions for interface modules can be found in the respective Equipment Manual.

3.9.1 Signed firmware update for interface modules

Signed firmware update

A signed firmware update ensures the authenticity and integrity of the firmware loaded onto a device.

It protects you against installing malicious firmware in case:

- Firmware was modified
- Firmware was downloaded from an incorrect internet source

Information on whether your interface module supports signed firmware updates is available in the Technical specifications section of the corresponding Equipment Manual.

Principle of signed firmware updates for interface modules

Firmware updates of interface modules may include a digital signature. The digitally signed firmware update files are available for download on the Siemens Support website.

The interface module verifies the authenticity and integrity of the firmware update file before installation using the digital signature with standardized asymmetric cryptography methods. As a result, the interface module can detect a manipulated or corrupted firmware update file and reject it.

Note that the interface module performs the verification only after the complete firmware download has taken place.

Subsequently, a notification is sent to the firmware update tool regarding the success or failure of the signature verification.

You still have all the options for firmware updates, as described in the Firmware update (Page 84) section, when performing signed firmware updates for interface modules. If the firmware update was not successful, the module will continue to run with the previous firmware.

Diagnostics alarms and remedy

When performing a firmware update for an interface module with an established connection between the IM and CPU, there are the following options for notifications in the CPU's diagnostic buffer:

- Successful integrity check of the firmware for the interface module
- Rejection of non-secure firmware for the interface module

You can find more information in the channel diagnostics table in the equipment manual of the interface module.

In case of firmware update rejection, proceed as follows:

1. Check whether the firmware update file used by you originates from a secure source and was downloaded unchanged. As a check, calculate the hash value of the downloaded firmware update file and compare it with the value specified on the download page.
2. Download the firmware again from the Siemens Support Web page.
3. Repeat the firmware update.

You can find information on the procedure for calculating and comparing hash values on the Internet (<https://support.industry.siemens.com/cs/de/de/view/109483101/en>).

3.9.2 Secure Boot for interface modules

Secure Boot

Secure Boot verifies, before the boot process, whether firmware has been falsified, for example through manipulation or accidental falsification.

Secure Boot ensures the authenticity and integrity of the firmware executed by the device.

Information on whether your interface module supports Secure Boot is available in the Technical specifications section of the corresponding Equipment Manual.

Principle of "Secure Boot" for interface modules

Interface modules verify the authenticity and integrity of the firmware to be executed using "Secure Boot" before being executed.

The verification is carried out using standardized asymmetric cryptography methods.

In addition to signed firmware updates for interface modules, Secure Boot also prevents manipulation of the firmware through physical intervention in the interface module.

Secure Boot is integrated into the interface module and cannot be deactivated for security reasons.

NOTE

Longer startup duration of the interface module

The signature verification of Secure Boot significantly extends the startup time of the interface module. You can find time specifications in the Equipment Manual of the interface module, in the Technical specifications section.

LED display on the interface module

If the Secure Boot verification results in an invalid signature, the LEDs RUN, ERROR, and MAINT on the interface module will flash. In this case, you need to replace the interface module.

3.10 Secure operation of I/O modules

Device-specific security information and instructions for I/O modules can be found in the respective Equipment Manual.

System overview

4.1 What is the SIMATIC ET 200BL distributed I/O system?

SIMATIC ET 200BL

ET 200BL is a distributed I/O system that has been specifically designed as a cost-effective automation solution for various markets and industries. This new system offers an attractive option with optimized functionality while maintaining SIMATIC quality standards.

Customer benefits of the system

Reducing the complexity	Optimization of investment costs	Established efficiency
<ul style="list-style-type: none"> • Quick module change without rewiring 	<ul style="list-style-type: none"> • Minimized assembly time thanks to tool-free connection technology 	<ul style="list-style-type: none"> • PROFINET communication
<ul style="list-style-type: none"> • Integrated power distribution reduces wiring effort 	<ul style="list-style-type: none"> • Reduced maintenance costs due to detachable front connectors 	<ul style="list-style-type: none"> • IRT capability for demanding applications
<ul style="list-style-type: none"> • Robust design for reliable operation 	<ul style="list-style-type: none"> • Space optimization through high channel density 	<ul style="list-style-type: none"> • Comprehensive certification package
<ul style="list-style-type: none"> • Wide temperature range to support various applications 		<ul style="list-style-type: none"> • Global support and availability



Figure 4-1 SIMATIC ET 200BL distributed I/O system - Customer benefits

4.1 What is the SIMATIC ET 200BL distributed I/O system?

Area of application

The ET 200BL is particularly suitable for a wide range of applications. It is ideal for cost-sensitive projects and is also perfect for installations with limited space due to its compact design. The system's adaptability makes it an excellent choice for global use, and its rugged design allows for reliable operation in temperature-critical environments, ensuring consistent performance under various operating conditions.

SIMATIC ET 200BL is designed as an open device according to IEC 61010-2-201 with the degree of protection IP20 and must be installed in a cabinet.

Configuration

The SIMATIC ET 200BL distributed I/O system is installed on a mounting rail. It consists of:

- Interface module
- Up to 16 I/O modules
- End cover

Configuration example

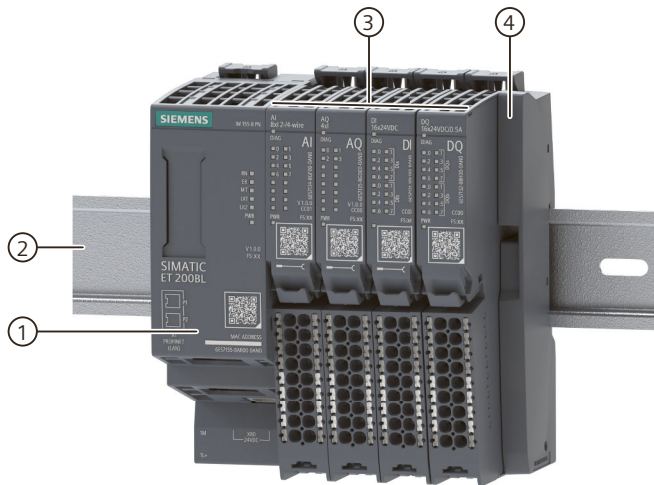



- ① Interface module
- ② Mounting rail
- ③ I/O modules
- ④ End cover

Figure 4-2 Example configuration of the ET 200BL distributed I/O system

4.2 Components

Basic components of the ET 200BL distributed I/O system

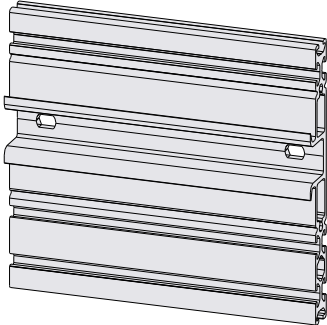
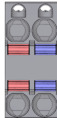

Table 4-1 Basic components of ET 200BL

Basic component	Function	Figure
Mounting rail in accordance with EN 60715	The mounting rail is the rack of the ET 200BL distributed I/O system. You install the ET 200BL system on the mounting rail. The mounting rail is 35 mm high.	
SIMATIC system rail	The SIMATIC system rail offers improved framework conditions for the assembly of rail structures: <ul style="list-style-type: none"> • Tight dimensional tolerances for high mechanical load operating conditions • Long-term stable surface coating for optimum interference suppression • Robust construction for self-supporting construction • Integrated Bosch profile grooves for easy and flexible installation as well as easy installation of accessories (mounting brackets and hinges, damping elements, shield connections, cable ducts, etc.) 	
Interface module for PROFINET IO	The interface module: <ul style="list-style-type: none"> • Can be used as IO device on PROFINET IO • Links the ET 200BL with the IO controller • Exchanges data with the I/O modules via the backplane bus. 	
I/O module	The I/O module determines the function at the terminals. The controller detects the current process state via the connected sensors and actuators, and triggers the corresponding reactions. I/O modules are divided into the following module types: <ul style="list-style-type: none"> • Digital input (DI) • Digital output (DQ) • Analog input (AI) • Analog output (AQ) • Technology (TM) • Communication (CM) 	

Basic component	Function	Figure
End cover	The end cover provides mechanical closure for an ET 200BL station.	

Accessories of the ET 200BL distributed I/O system

Table 4-2 Accessories of ET 200BL

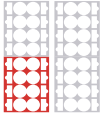
Accessories	Function	Figure
24 V DC plug	Applying the 24 V DC supply on the plug and connection with the interface module. The 24 V DC plug is available as a spare part.	
Labeling strips	Attach the labeling strips to the interface module for system-specific labeling of the ET 200BL distributed I/O system. The labeling strips can be printed. The labeling strips can be ordered as accessories on a roll for thermal transfer printers or as DIN A4 format sheets for laser printers.	
Reference identification labels	The labels enable the reference designation of the ET 200BL components. The labels can be ordered on a mat for thermal transfer and inkjet printers as accessories.	
Color identification labels	The color identification labels are module-specific and can be ordered for the process terminals as accessories.	

Application planning

5.1 Hardware configuration

Maximum mechanical configuration

The ET 200BL distributed I/O system supports up to 16 modules.

Address space

The address space depends on the CPU (see CPU Equipment Manuals) and the interface module used (see Equipment Manual of the interface module

(<https://support.automation.siemens.com/WW/view/en/109987777>)).

5.2 Forming potential groups

Self-establishing field power bus

DI, AI or AQ modules build up a field power bus. DQ modules interrupt the field power bus.

You can feed the supply voltage L+ and ground of the field power bus via a DI, AI or AQ module at any point in the potential group.

Each DI, AI and AQ module enables access to the supply voltage L+ and the ground of the field power bus via terminals (17 for L+/18 for ground).

Placement and grouping of I/O modules

Each DQ module that you install in the ET 200BL setup interrupts the field power bus and terminates a potential group. This allows individual grouping of the supply voltages. You have to supply DQ modules separately with supply voltage L+ and ground since they are not part of the field power bus.

There are no restrictions on which module type you use in which slot and there is no limitation on the length of the load current supply bus.

NOTE

All modules placed in a load group must correspond to the same infeed potential.

NOTE

The corresponding symbol ([Page 66](#)) indicates which I/O modules make up the field power bus.

Example

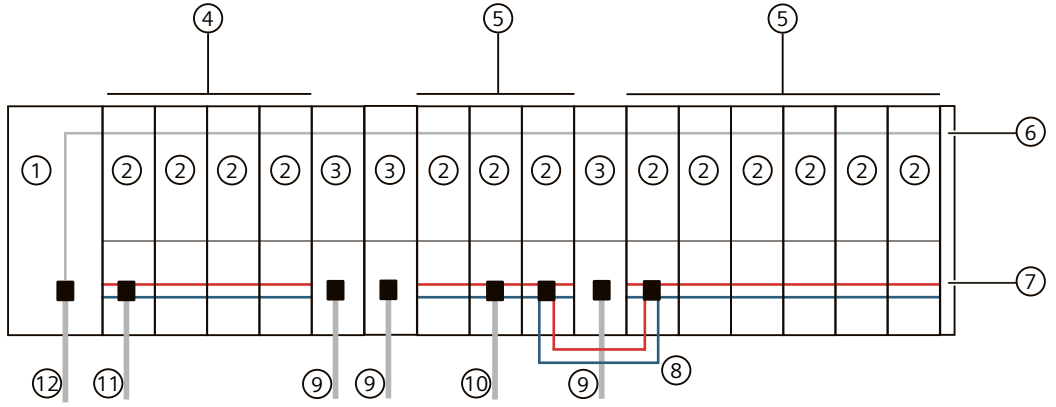

- ① Interface module
- ② DI, AI or AQ module
- ③ DQ module
- ④ Potential group 1
- ⑤ Potential group 2
- ⑥ Backplane bus
- ⑦ Self-establishing field power bus P1/P2
- ⑧ Bridging a DQ module
- ⑨ Supply voltage L+ and ground for DQ modules
- ⑩ Supply voltage L+ and ground for potential group 2
- ⑪ Supply voltage L+ and ground for potential group 1
- ⑫ Supply voltage 1L+ and ground

Figure 5-1 Placing the DQ module

Installation

6.1 Basics

Introduction

All modules of the ET 200BL distributed I/O system are open equipment in accordance with IEC 61010-2-201. This means you may only install the ET 200BL distributed I/O system in housings, cabinets or electrical operating rooms and in a dry indoor environment (degree of protection IP20). The housings, cabinets and electrical operating rooms must guarantee protection against electric shock and spread of fire. The requirements regarding mechanical strength must also be met. The housings, cabinets, and electrical operating rooms must not be accessible without a key or tool. Personnel with access must have been trained or authorized.

Installation location

Install the ET 200BL distributed I/O system in a suitable enclosure/control cabinet with sufficient mechanical strength and fire protection. Take into account the environmental conditions for operating the devices.

Mounting position

You can mount the ET 200BL distributed I/O system in any position. The preferred mounting position is horizontal mounting on a vertical wall.

The ambient temperature may be restricted in certain installation positions. You will find more information in section Mechanical and climatic environmental conditions ([Page 97](#)).

Mounting rail

Install the ET 200BL distributed I/O system on a mounting rail in accordance with EN 60715 (35 × 7.5 mm or 35 × 15 mm) or on a SIMATIC system rail.

You need to ground the mounting rail separately in the control cabinet. Exception: If you install the rail on grounded, zinc-plated mounting plates, there is no need to ground the rail separately.

NOTE

If the ET 200BL distributed I/O system is exposed to vibration and shock loads, both ends of the ET 200BL system assembly must be mechanically fixed to the mounting rail (e.g using 8WA1010-1PH01 ground terminals). This measure prevents the ET 200BL distributed I/O system from shifting to the side.

NOTE

If the ET 200BL distributed I/O system is exposed to increased vibrations and shock load, fasten the mounting rail to the mounting surface at intervals of approx. 200 mm.

For increased vibration and shock loads, you can mount the ET 200BL system on the SIMATIC system rail.

The following are suitable surfaces for the mounting rails:

- Steel strip in accordance with Appendix A of EN 60715 or
 - Tinned steel strip. We recommend these in conjunction with the mounting rails in the section Accessories/spare parts ([Page 103](#)).
-

NOTE

If you use mounting rails from other manufacturers, make sure that they have the required properties for your ambient climatic conditions.

Minimum clearances

The figure below shows the minimum clearances you must observe when installing or dismantling the ET 200BL distributed I/O system.

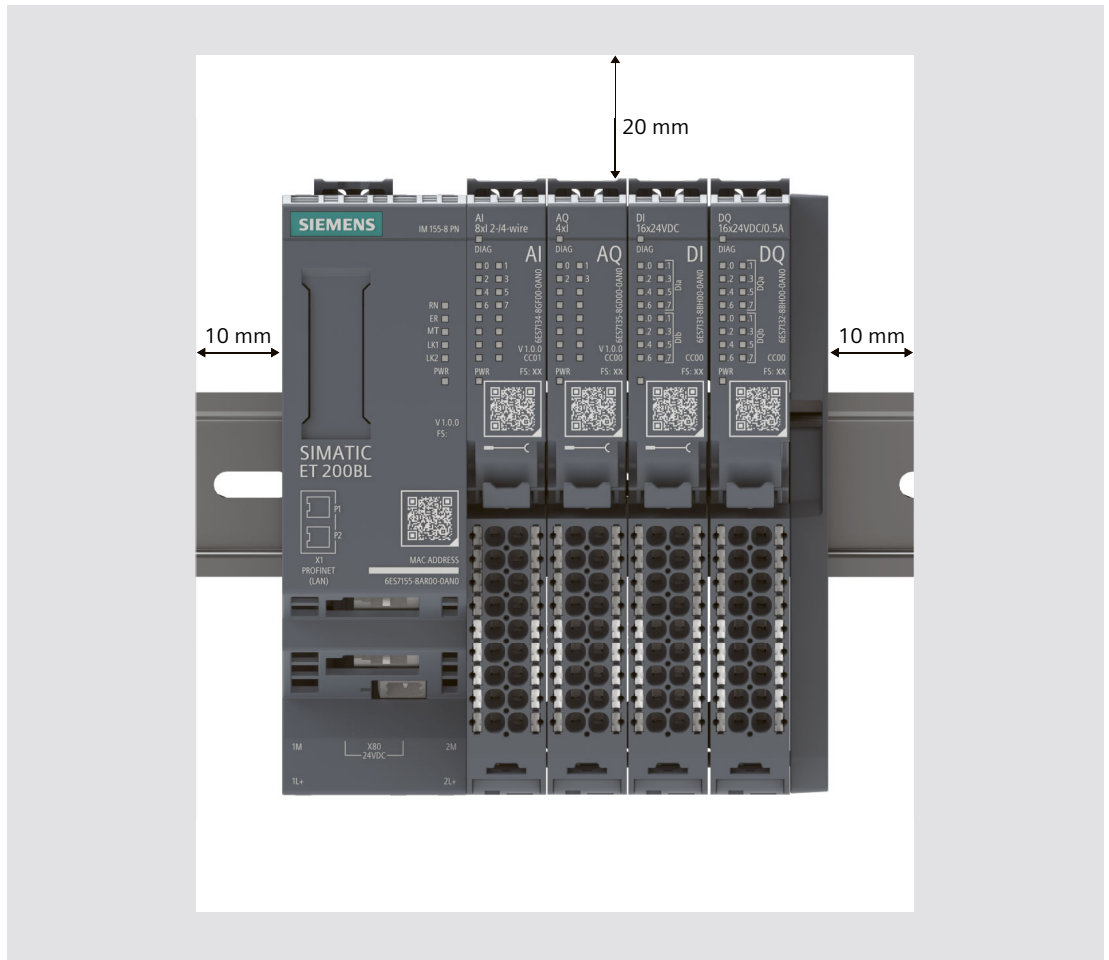

Figure 6-1 Minimum clearances

General rules for installation

 **WARNING**

**Hazardous Voltage
Can Cause Death, Serious Injury, or Property Damage.**

Hazardous electrical voltage can cause electric shock, burns and property damage.
Disconnect your system and devices from the power supply before starting any assembly tasks.

Observe the following rules:

- The installation begins on the left with an interface module.
- The end cover completes the configuration of the ET 200BL distributed I/O system.

NOTE

Mount the ET 200BL distributed I/O system only with disconnected supply voltage.

 **WARNING**

Protection from conductive contamination

Taking into account the environmental conditions, the devices must be protected from conductive contamination.
This can be achieved, for example, by installing the devices in a control cabinet with the appropriate degree of protection.

Mounting rules for reducing the thermal load

The following rules reduce the thermal stress of the ET 200BL distributed I/O system in the control cabinet:

- You should give preference to the horizontal mounting position.
- For vertical mounting position, plug modules with high power dissipation at the top, the interface module at the bottom.
- Install an ET 200BL station with modules with high power dissipation in the lower area of the control cabinet.
- For a multi-tier configuration, plug modules with high power dissipation on the sides so that the waste heat can rise to the top unhindered.

6.2 Installing/removing an interface module

Introduction

The interface module connects the ET 200BL distributed I/O system with the fieldbus and exchanges data between the higher-level controller and the I/O modules.

NOTE

You have the option of pre-assembling an entire ET 200BL station. You can mount the pre-assembled station to a DIN rail or SIMATIC system rail. The mounting rail releases are in the lower position.

When all mounting rail releases are in the lower position, you can remove the entire station from a DIN rail or SIMATIC system rail.

Requirements

- The mounting rail is fitted.
- The mounting rail release of the interface module is in the upper position.

 WARNING
Hazardous voltage Hazardous electrical voltage can cause electric shock, burns and property damage. Disconnect your system and devices from the power supply before starting any assembly tasks.

Installing the interface module

To install the interface module, follow these steps:

1. Hook the interface module onto the mounting rail.
2. Swivel the interface module back until you hear the mounting rail release button click into place.



Figure 6-2 Installing the interface module

3. Check that the mounting rail release is in the upper position.

Uninstalling the interface module

The interface module is wired and I/O modules are located to the right of it.

To uninstall the interface module, follow these steps:

1. Switch off the supply voltage for the interface module. Pull the 24 V DC plug from the interface module.
2. Press the mounting rail release firmly on the interface module once.
As a result, the mounting rail release snaps into place and you do not have to press it permanently during disassembly. It also makes it easier to move the interface module.
3. On the first I/O module, press the mounting rail release slightly up to the pressure point. At the same time, shift the interface module parallel to the left until it detaches from the rest of the module group.

NOTE

The mounting rail release button is located above the interface module or I/O module.

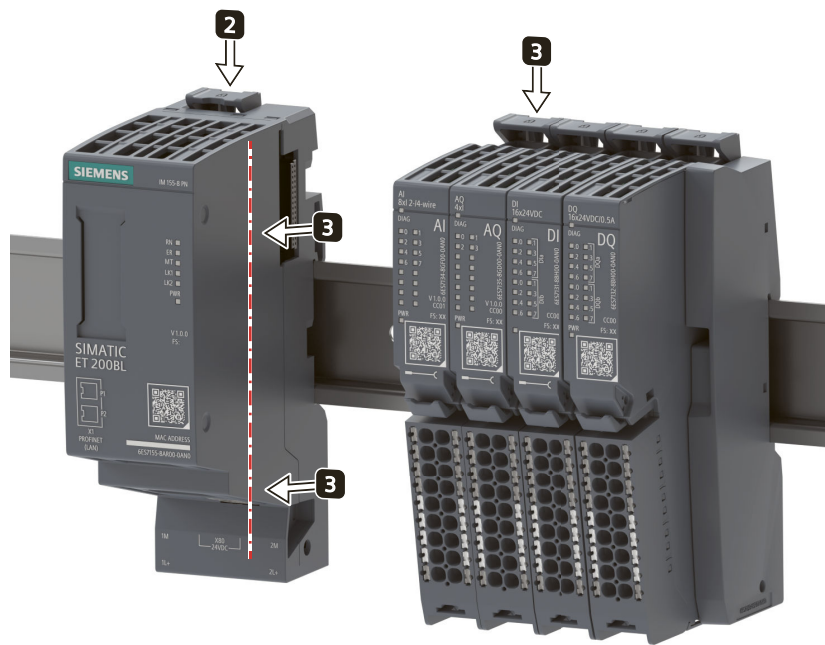

Figure 6-3 Uninstalling the interface module

4. Swivel the interface module out of the mounting rail.

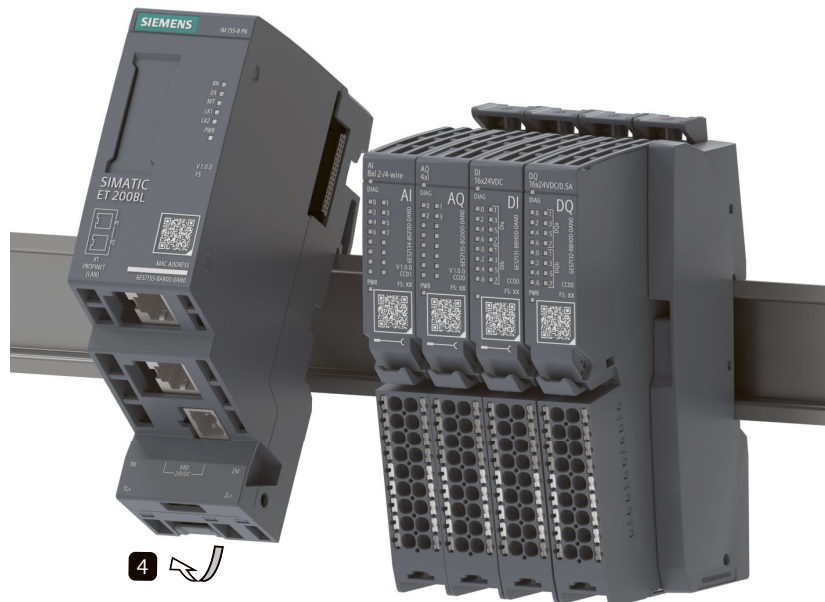

Figure 6-4 Uninstalling the interface module

6.3 Installing/removing I/O modules

Introduction

The I/O modules are used for electromechanical connection between the individual ET 200BL components. They also provide terminals for connecting external sensors, actuators and other devices.

Requirements

- The mounting rail is fitted.
- The mounting rail release of the I/O module is in the upper position.

! WARNING
Hazardous voltage
Hazardous electrical voltage can cause electric shock, burns and property damage. Disconnect your system and devices from the power supply before starting any assembly tasks.

Installing an I/O module

Proceed as follows to install an I/O module:

1. Hook the I/O module onto the mounting rail.
2. Swivel the I/O module to the rear until you hear it click into the mounting rail.
3. Move the I/O module parallel to the left until you hear it click into place at the interface module or the left I/O module.

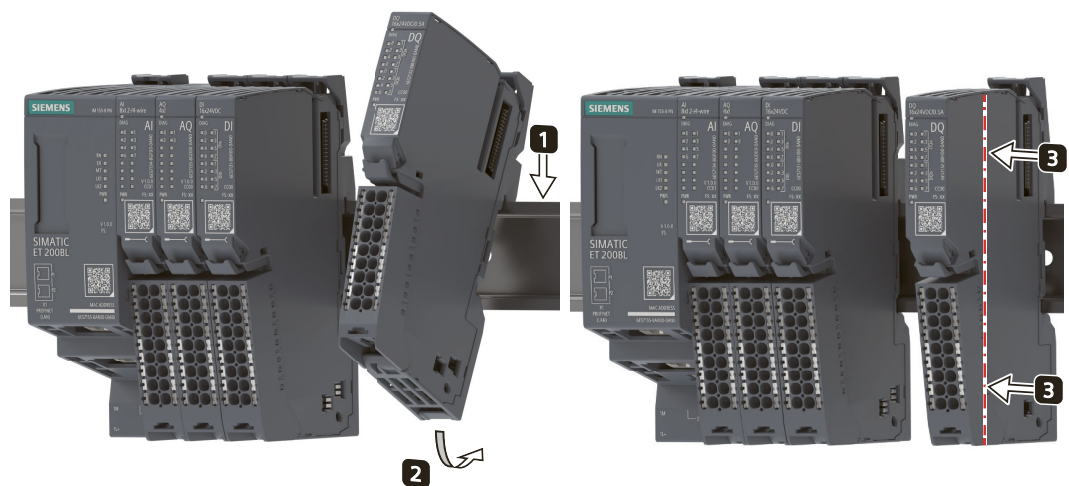

Figure 6-5 Installing an I/O module

4. Check that the mounting rail release is in the upper position.

Removing I/O modules

Proceed as follows to dismantle an I/O module:

The I/O module is wired and there are other I/O modules to its right and left:

To remove a specific I/O module, move the neighboring I/O modules. As soon as there is a free space of approx. 8 mm from the neighboring I/O module, you can remove the desired I/O module.

To **disassemble from the right**, proceed as follows:

1. Switch off all supply voltages on the ET 200BL distributed I/O system.
2. Remove the terminal block (Page 82) (if wired) from the I/O module that you want to remove.
3. Press the mounting rail release firmly once on the I/O module that you want to remove.

As a result, the mounting rail release snaps into place and you do not have to press it permanently during disassembly. In addition, this makes it easier to move the I/O module.

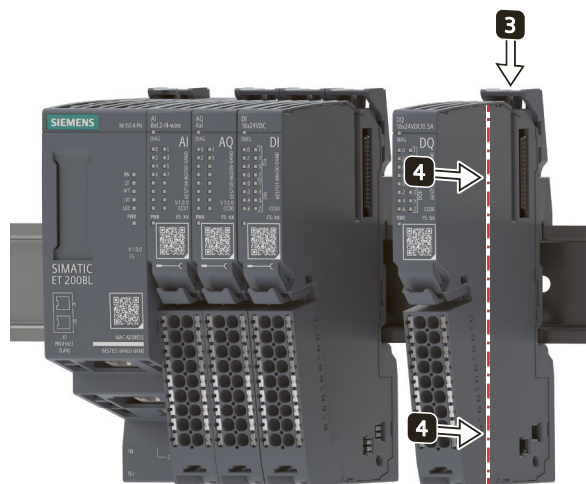

Figure 6-6 Disassembly of the I/O module (disassembling from the right)

4. Move the I/O module parallel to the right and swivel the I/O module off the mounting rail.

To **disassemble from the left**, proceed as follows:

1. Switch off all supply voltages on the ET 200BL distributed I/O system.
2. Remove the interface module as described under "Installing/removing an interface module (Page 47)".
3. Remove the terminal block (Page 82) (if wired) from the I/O module that you want to remove.
4. Press the mounting rail release firmly once on the I/O module that you want to remove.

As a result, the mounting rail releases snap into place and you do not have to press them permanently during disassembly. It also makes it easier to move the left I/O module.

NOTE

The mounting rail release button is located above the I/O module.

6.4 Installing/uninstalling the end cover

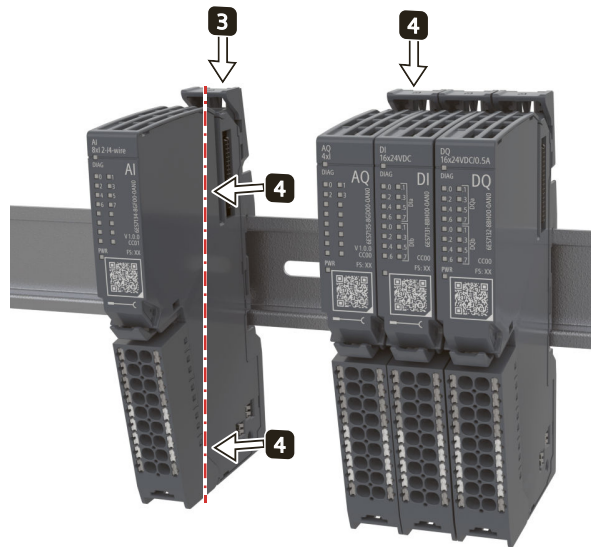



Figure 6-7 Disassembly of the I/O module (disassembling from the left)

- 5. On the I/O module which is located to the right of the I/O module that you want to remove, press the mounting rail release slightly up to the pressure point. Move the I/O module parallel to the left and swivel the I/O module out.

6.4 Installing/uninstalling the end cover

Introduction

The right end of the ET 200BL station is closed with the end cover.

 WARNING
Hazardous electrical voltage can cause electric shock, burns and property damage. Close the right end of the ET 200BL station with an end cover.

Requirement

The last I/O module is installed.

Installing the end cover

To install the end cover, follow these steps:

1. Install the end cover in the mounting rail on the right next to the last I/O module.
2. Swivel the end cover to the rear on the mounting rail.
3. Move the end cover parallel to the left until you hear it click into the preceding, last I/O module.

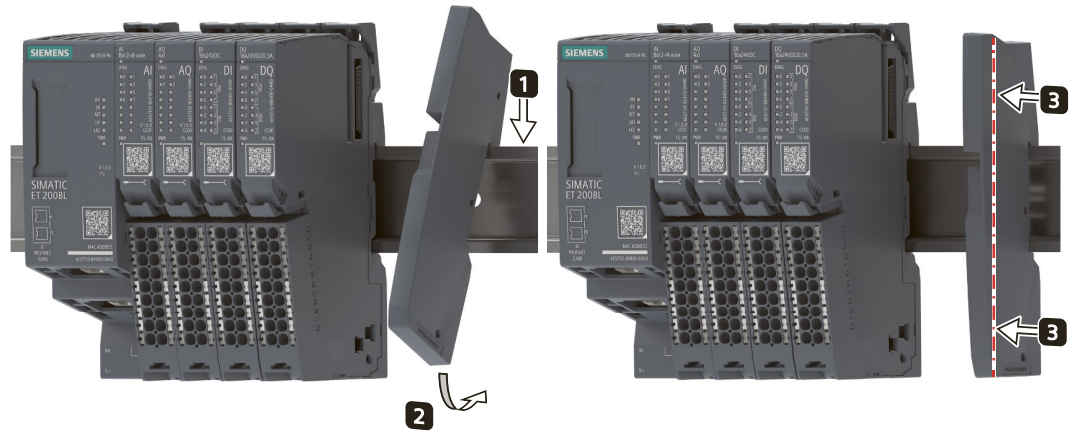
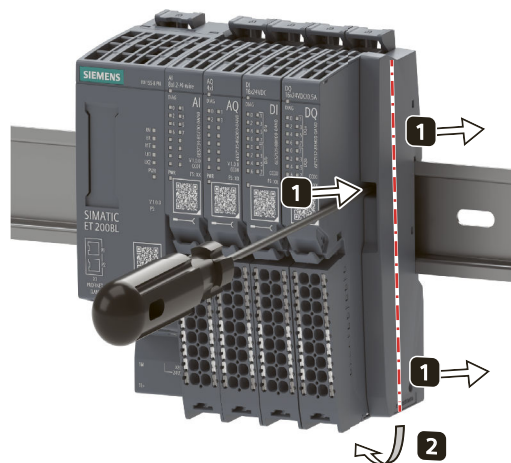

Figure 6-8 Installing the end cover

Uninstalling the end cover

To uninstall the end cover, follow these steps:

1. Using a screwdriver, move the end cover parallel to the right.



2. Swivel the end cover out of the mounting rail.

Wiring

7.1 Rules and regulations for operation

Introduction

When installing the ET 200BL distributed I/O system as part of a plant or system, special rules and regulations need to be adhered to depending on the area of application.

This section provides an overview of the most important rules that must be observed for the integration of the ET 200BL distributed I/O system in a plant or system.

Specific application

Adhere to the safety and accident prevention regulations applying to specific applications, for example machine protection guidelines.

EMERGENCY STOP devices

EMERGENCY STOP devices in accordance with IEC 60204 (corresponds to DIN VDE 0113) must remain effective in all operating modes of the plant or system.

External fuses/switches

Install the external fuses/breakers in the proximity of the ET 200BL distributed I/O system.

Excluding hazardous plant states

Hazardous operating states must not occur when

- the plant restarts after a voltage dip or power failure.
- Bus communication is reestablished following a fault.

If necessary, EMERGENCY STOP must be forced!

An uncontrolled or undefined startup must not occur after the EMERGENCY STOP is unlocked.

Line voltage

Below, everything you need to consider in terms of line voltage is described (refer to section Insulation, protection class, degree of protection and rated voltage (Page 99)):

- For fixed plants or systems without an all-pole mains disconnection switch, a mains disconnection device (all-pole) must be available in the building installation.
- For load power supplies, the configured rated voltage range must correspond to the local line voltage.
- For all power circuits of the ET 200BL distributed I/O system, the fluctuation/deviation of the line voltage from the rated value must be within the permitted tolerance.

24 V DC supply

Below you will find a description of what you need to pay attention to with 24 V DC supply:

- In the event of danger through overload, you must provide lightning protection measures:
 - For external lightning protection
 - For internal lightning protection: Only if greater values (phase - ground) or (phase - phase) are required for the power surge than those specified in the section Electromagnetic compatibility (Page 99).
- For 24 V DC supply: Ensure safe (electrical) separation and separate cable routing or increased isolation of circuits with dangerous potentials from safety extra-low voltage (SELV) in accordance with IEC 60950-1.

Requirements for power supplies in the event of voltage interruption

NOTE

To ensure adherence to IEC 61131-2, only use power packs/power supply units (e.g. 230/400 V AC → 24 V DC) with a mains buffering time of at least 10 ms. Observe the relevant requirements in your application (e.g. product standard for "burners" 30 ms according to EN 298) with respect to possible voltage interruptions. The latest up-to-date information on PS components is available on the Internet (<https://mall.industry.siemens.com>).

Of course, these requirements also apply to power packs/power supply units not constructed using ET 200BL or S7-1500/S7-300-/S7-400 design.

Protection against outside electrical influences

Below is a description of what you must pay attention to in terms of protection against electrical impacts and/or faults:

- Make sure that the system for discharging electromagnetic interference is connected to functional earth or to protective conductor with a sufficient cross-section for all plants with an ET 200BL distributed I/O system.
- For supply, signal and bus lines, you must ensure that the laying of the lines and the installation is correct.
- For signal and bus lines, you must ensure that a wire/cable break or a cross-circuit does not lead to undefined states of the plant or system.

Reference

You can find more information in the Designing interference-free controllers (<https://support.automation.siemens.com/WW/view/en/59193566>) function manual.

7.2 Operation of ET 200BL on grounded infeed

Introduction

Below you will find information on the overall configuration of an ET 200BL distributed I/O system on a grounded infeed (e.g. TN-S network). The specific subjects discussed are:

- Disconnecting devices and short-circuit and overload protection according to IEC 60364 (corresponds to DIN VDE 0100) and IEC 60204 (corresponds to DIN VDE 0113)
- Load power supplies and load circuits.

Grounded incoming supply

In the case of grounded incoming supplies (TN-S system) the neutral conductor (N) and the protective conductor (PE) are each grounded. Both conductors form a part of the overvoltage concept. When a plant is in operation, the current flows across the neutral conductor. When a fault occurs, for example, a single ground fault between a live conductor and ground, the current flows through the protective conductor.

Safe electrical separation (SELV according to IEC 61010-2-201)

Load power supplies/power supply modules with 24 V DC output voltage require safe electrical separation and voltage limiting (extra low voltage). Load power supplies/power supply modules with 24 V DC output voltage are not connected to the protective conductor. According to IEC 61131-2 and IEC 61010-2-201, this protection is referred to as SELV (Safety Extra Low Voltage).

The wiring of SELV circuits must be safely separated from the wiring of other circuits that are not SELV, or the insulation of all conductors must be dimensioned for the higher voltage.

Setting up ET 200BL with ungrounded reference potential

To conduct interference currents, the reference potential of the interface module and the I/O modules is connected internally via an RC combination (IM: $R = 10\text{ M}\Omega$ / typically $C = 100\text{ nF}$, I/O modules: $R = 10\text{ M}\Omega$ / typically $C = 4\text{ nF}$) connected to the mounting rail (functional grounding).

- This configuration conducts high-frequency interference currents and prevents static charges.
- It is always possible to configure an ungrounded setup of the ET 200BL distributed I/O system as the ET 200BL distributed I/O system has no fixed ground connection. The power pack/power supply module for 24 V DC must also be ungrounded and electrically isolated.

For grounded setup, see the following figure "ET 200BL in the overall configuration".

Short-circuit / overload protection

Various measures as protection against short-circuits and overloads are required for setting up a full installation. The type of components and the binding protective measures depend on which IEC (DIN VDE) regulation applies to your system configuration. The table refers to the figure below and compares the IEC (DIN VDE) regulations.

Table 7-1 Components and protective measures

	Reference to the following image	IEC 60364 (DIN VDE 0100)	IEC 60204 (DIN VDE 0113)
Disconnecting device for controller, sensors, and actuators	①	Main switch	Disconnecter
Short-circuit / overload protection: In groups for sensors and actuators	② ③	Single-pole protection of circuits	With grounded secondary circuit: single-pole protection otherwise: all-pole protection
Load current supply for AC load circuits with more than five items of electro-magnetic equipment	②	Galvanic isolation by transformer recommended	Galvanic isolation by transformer recommended

Cable temperature measurement threshold

NOTE

Cable temperature measurement threshold

When selecting a cable, note that the cable temperature during operation can be up to 40 °C higher than the ambient temperature of the ET 200BL system (example: At an ambient temperature of 60 °C, a connection conductor must be designed for a temperature range of at least 100 °C).

You should specify other connection types and material requirements based on the electrical characteristics of the circuits you use and the installation environment.

ET 200BL in the overall configuration

The figure below shows the overall configuration of the ET 200BL distributed I/O system (load current supply and grounding concept) with infeed from a TN-S network.

Own distribution/Zone B

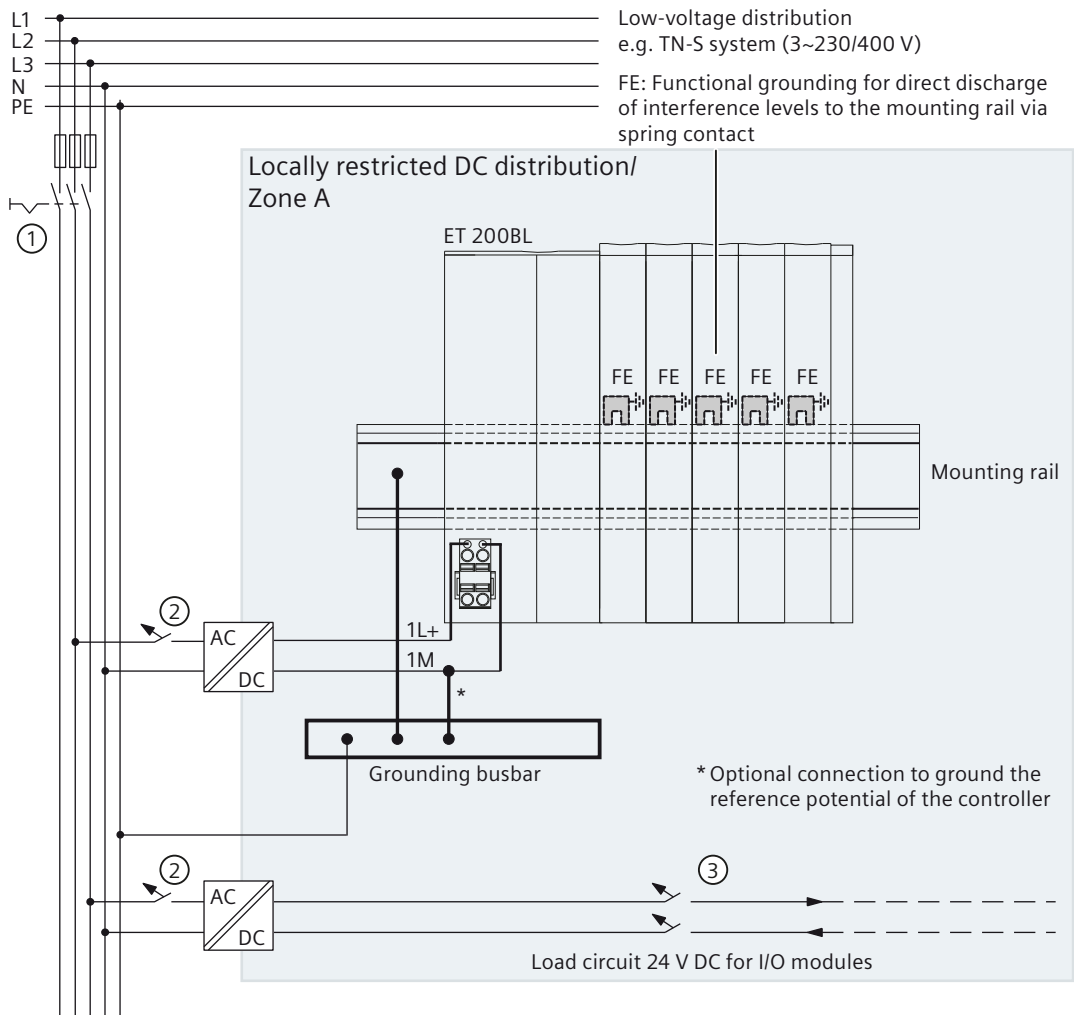

- ① Main switch
- ② Short-circuit / overload protection
- ③ Load current supply

Figure 7-1 ET 200BL in the overall configuration

NOTE

In general, you need to connect the DC I/O modules of the ET 200BL distributed I/O system to your own distribution (or batteries) via an upstream, local power supply unit. If you connect the DC I/O modules directly to your own distribution, you need to provide additional protective measures against overvoltages.

7.3 Electrical configuration of the ET 200BL

Electrical isolation

Electrical relationships

With the ET 200BL distributed I/O system, there is electrical isolation between:

- The load circuits/process and all other circuit components of the ET 200BL distributed I/O system.
- The communications interfaces of the interface module and all other circuit components.

The following figure shows the potential relationships of the ET 200BL distributed I/O system with the interface module. Only the most important components are represented in the image.

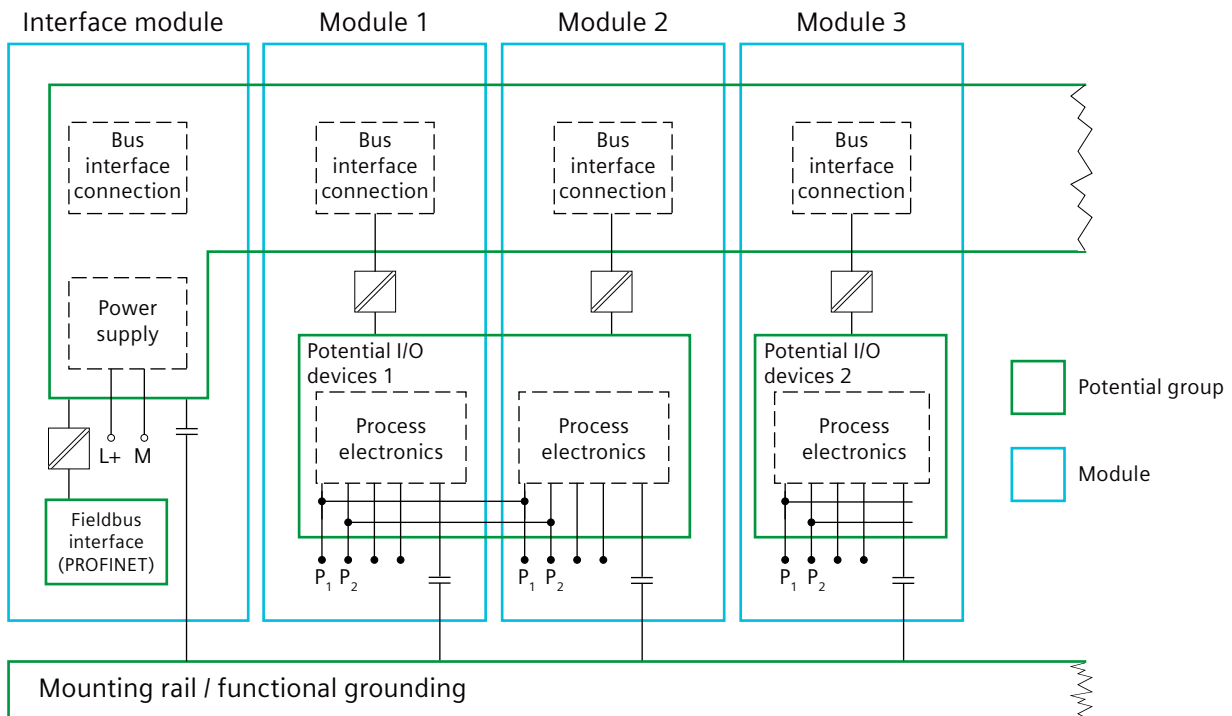

Figure 7-2 Electrical relationships for ET 200BL with interface module (using IM 155-8 PN as an example)

7.4 Wiring rules

Introduction

Use suitable cables to connect the ET 200BL distributed I/O system. Also select the cable insulation corresponding to the applied voltage. The tables below set out the wiring rules for interface modules and I/O modules.

CAUTION

Use copper cables on connectors with terminal connections

Use only copper cables (Cu) for all signal and supply lines that are connected to the device via terminals, e.g. 24 V DC power supply cable to the 24 V DC power supply connections.

Wiring rules for the interface module and I/O modules

If you use cables whose cross-section is specified in mm², the following table in accordance with IEC 60999-1 applies:

Wiring rules for ...		Interface module (supply voltage)	I/O modules (Push-in terminal)
Connectable cable cross-sections for solid cables (Cu)		0.2 to 2.5 mm ²	
Connectable cable cross-sections for flexible cables (Cu)	Without end sleeve	0.2 to 2.5 mm ²	
	With end sleeve (with plastic sleeve)	0.25 to 1.5 mm ²	0.14 to 1.5 mm ²
	With end sleeve (without plastic sleeve)	0.25 to 2.5 mm ²	0.14 to 1.5 mm ²
	With TWIN end sleeve	0.5 to 1 mm ²	0.5 to 0.75 mm ² (see below)
Stripping length of the cables		8 to 10 mm	
End sleeves in accordance with DIN 46228 with plastic sleeve		8 and 10 mm long	
TWIN end sleeves		12 mm long	

If you use cables that are based on AWG (American Wire Gauge), the following table in accordance with UL 486-E applies:

Wiring rules for ...		Interface module (supply voltage)	I/O modules (Push-in terminal)
Connectable cable cross-sections for solid cables (Cu)		AWG: 24 to 13	AWG: 24 to 14 (2.1 mm ²)
Connectable cable cross-sections for flexible cables (Cu)	Without end sleeve	AWG: 24 to 13	AWG: 24 to 14
	With end sleeve (with plastic sleeve)	AWG: 24 to 16	AWG: 26 to 16
	With end sleeve (without plastic sleeve)	AWG: 24 to 13	AWG: 26 to 16
	With TWIN end sleeve	AWG: 20 to 17	AWG: 20 to 18 (see below)

Wiring rules for ...	Interface module (supply voltage)	I/O modules (Push-in terminal)
Stripping length of the cables	8 to 10 mm	
End sleeves in accordance with DIN 46228 with plastic sleeve	8 and 10 mm long	
TWIN end sleeves	12 mm long	

TWIN end sleeves for the cables of the I/O modules' push-in terminals

Due to the space required by TWIN end sleeves with 0.75 mm² cross-section, you must ensure a correct angle for the cable arrangement when crimping the TWIN end sleeve so that the cables are optimally arranged.

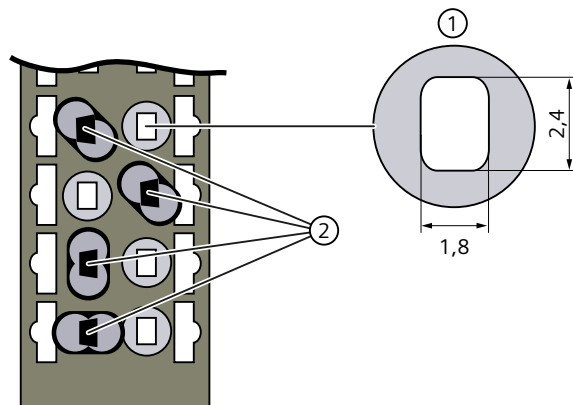

- ① Cross-section of the terminal compartment
- ② Crimping TWIN end sleeves at the correct angle

Figure 7-3 TWIN end sleeves

Cable temperature measurement threshold

NOTE

Cable temperature measurement threshold

When selecting a cable, note that the cable temperature during operation can be up to 40 °C higher than the ambient temperature of the ET 200BL system (example: At an ambient temperature of 60 °C, a connection conductor must be designed for a temperature range of at least 100 °C).

You should specify other connection types and material requirements based on the electrical characteristics of the circuits you use and the installation environment.

7.5 Wiring I/O modules

Introduction

I/O modules form the interface between the controller and the process. The controller detects the current process state via the connected sensors and actuators, and triggers the corresponding reactions.

NOTE

The pin assignment of the I/O modules depends on the I/O module used. You can find information about the respective I/O module in the associated equipment manuals.

NOTE

Special terminal markings in the wiring and block diagrams of the I/O modules

- **RES:** Reserve, these terminals must remain unconnected so that they can be used for future expansions
 - **n.c.:** Not connected, these terminals have no function. However, they can be connected to potentials specifically defined for a module, for example, for the laying unused wires.
-

Requirements

- The supply voltages are turned off.
- Follow the wiring rules.

Required tools

3 to 3.5 mm screwdriver

View of push-in terminals

The figure below shows a view of push-in terminal.

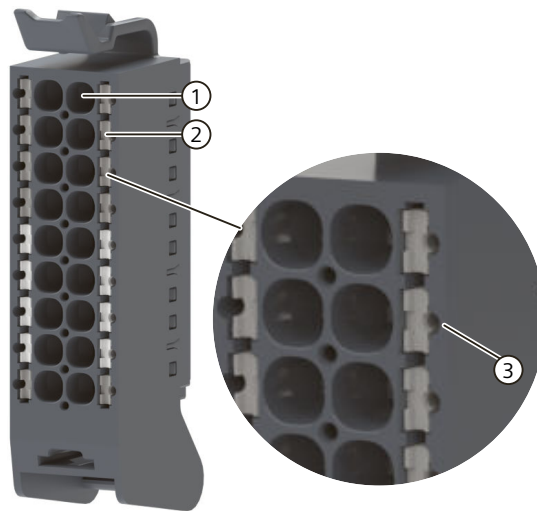

- ① Push-in terminal
- ② Spring release
- ③ Opening for test probes (suitable test probes: 1 mm diameter, length \geq 10 mm while observing the permitted voltage category)

Figure 7-4 View of push-in terminals

Tool-free connection of cables: single-wire without end sleeve, multi-wire (stranded) with end sleeve or ultrasonically sealed

To connect a wire without tools, follow these steps:

1. Strip 8 to 10 mm of the wires.
2. Only in the case of stranded conductors (except for 2.5 mm² cross-section):
Seal or crimp the wire with end sleeves.
3. Insert the wire into the push-in terminal as far as it will go.

Connection of cables: multi-wire (stranded), without end sleeve, unfinished

To connect a wire without end sleeve, follow these steps:

1. Strip 8 to 10 mm of the wires.
2. Push with the screwdriver into the spring release.
3. Insert the wire into the push-in terminal as far as it will go.
4. Pull the screwdriver out of the spring release.

Removing wires

Using the screwdriver, press the spring release of the terminal as far as it will go and pull out the wire.

NOTE

When you press the spring release, you should not pull on the wire/cable at the same time. This prevents you from damaging the terminal.

7.6 Connecting supply voltage on the interface module

Introduction

The supply voltage of the interface module is supplied via a 4-pin connection plug located on the front of the interface module.

Power supply unit

Only use power supply units of the type SELV with safe electrically isolated functional extra low voltage (≤ 28.8 V DC).

Connection for supply voltage (X80)

The connections of the 4-pole connector have the following meaning:

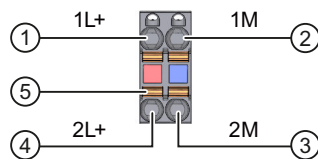

- ① +24 V DC of the supply voltage (current limited to 10 A)
- ② Ground of the supply voltage (current limited to 10 A)
- ③ Ground of the supply voltage for loop-through
- ④ +24 V DC of the supply voltage for loop-through
- ⑤ Spring opener (one spring opener per terminal)

1L+ and 2L+ and 1M and 2M are internally jumpered

Figure 7-5 Supply voltage connection

A strain relief is not present. The cable connector offers you the option of looping the supply voltage uninterrupted, even when it is unplugged.

For the maximum wire cross-sections, observe the information in the tables of the wiring rules.

Requirements

- Only wire up the connector plug when the supply voltage is turned off.
- Follow the wiring rules.

Required tools

3 to 3.5 mm screwdriver

Tool-free connection of cables: single-wire without end sleeve, multi-wire (stranded) with end sleeve or ultrasonically sealed

To connect a wire without tools, follow these steps:

1. Strip 8 to 10 mm of the wires.
2. Only in the case of stranded conductors:
Seal or crimp the wire with end sleeves.
3. Insert the wire into the push-in terminal as far as it will go.
4. Push the wired connector plug into the plug socket of the interface module.

Connection of cables: multi-wire (stranded), without end sleeve, unfinished

To connect a wire without end sleeve, follow these steps:

1. Strip 8 to 10 mm of the wires.
2. Using a screwdriver, press the spring release and insert the wire into the push-in terminal as far as it will go.
3. Pull the screwdriver out of the spring release.
4. Push the wired connector plug into the socket in the interface module.

Removing a wire

Using the screwdriver, press the spring release as far as it will go and pull out the wire.

7.7 Connecting interfaces for communication

Connect the communications interfaces of the ET 200BL distributed I/O system using the standardized plug connector. If you want to fabricate the communication cables yourself, the pin assignment is specified in the Equipment Manual of the interface module. Observe the mounting instructions for the connectors.

7.8 Labeling the ET 200BL

7.8.1 Factory markings

Introduction

For better orientation, the ET 200BL is equipped with various markings ex factory, which help in the configuration and connection of the modules.

Factory markings

- Module labeling
- Module information
 - Functional version of the module
 - ID Link
- Color coding of the spring releases
 - Process terminals: gray, white
 - Terminals for self-establishing field power bus P1, P2: Identifier 17 for L+ gray, identifier 18 for ground gray

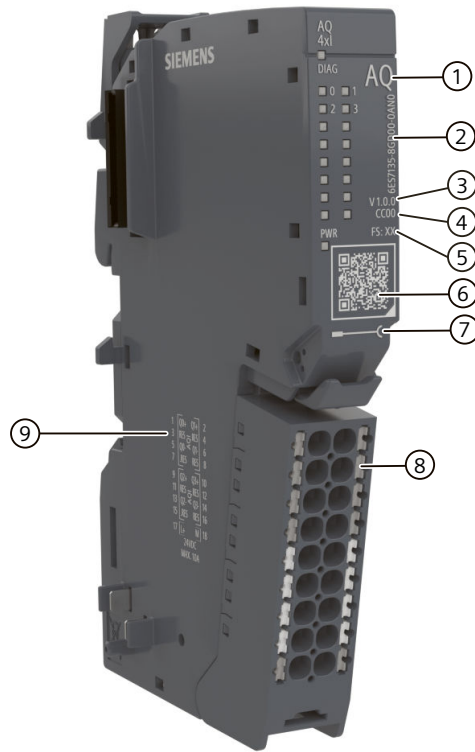

- ① Module type and name
- ② Article number
- ③ Firmware version (if firmware update possible)
- ④ Color code for selecting the color-coded labels
- ⑤ Functional version
- ⑥ ID Link
- ⑦ Symbol for I/O modules that support the load current supply bus
- ⑧ Color coding of the spring releases (by group)
- ⑨ Connection diagram

Figure 7-6 Factory markings

7.8.2 Optional markings

Introduction

In addition to the factory markings, there are also other options for labeling and/or marking terminals, interface modules and I/O modules for the ET 200BL distributed I/O system.

Optional markings

Color identification labels

The color identification labels are module-specific labels for color coding the potentials of the I/O modules. A color code (e.g. CC01) is printed on each color-coded label and I/O module. The color code allows you to read which color-coded label is required for the terminals directly from the I/O module.

The following versions of color coded labels are available:

- Module-specific color combinations for the process terminals (see the Equipment Manuals of the I/O modules).
The different colors have the following meaning: Gray = input or output signal, red = potential +, blue = ground.

Reference identification labels

The reference identification labels (in accordance with EN 81346) can be placed on each interface module and each I/O module.

With the standard plotter setting, the reference identification label is suitable for automatic labeling with E-CAD systems.

Labeling strips

The labeling strips can be inserted in the interface module and provide identification of the ET 200BL distributed I/O system. The labeling strips can be ordered on a roll for thermal transfer printers or as DIN A4 format sheets for laser printers.

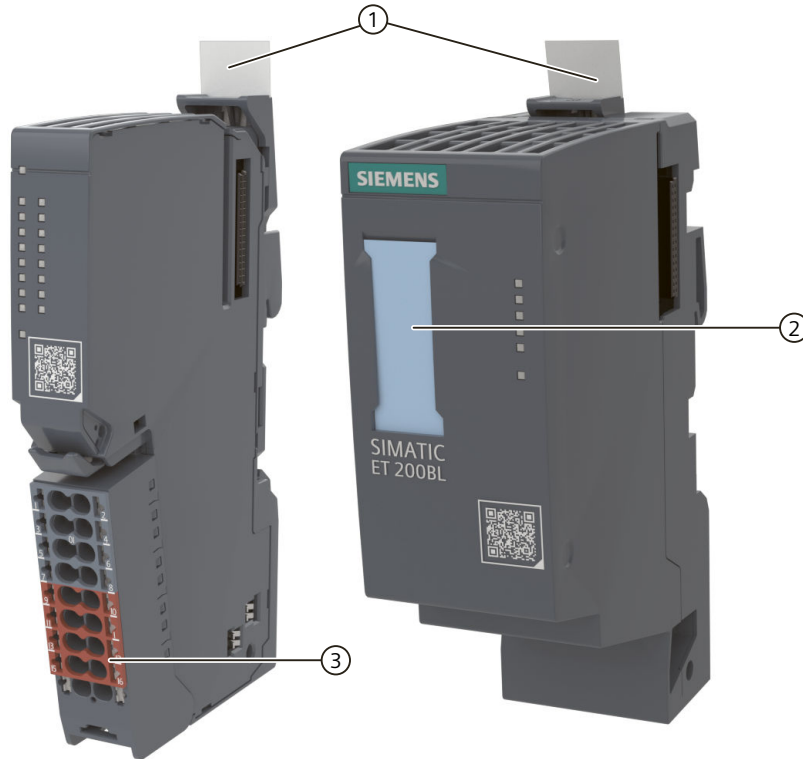

- ① Reference identification labels
- ② Labeling strips
- ③ Color-coded label

Figure 7-7 Optional markings

7.8.3 Applying color identification labels

Requirements

The I/O module must not be wired when you apply the color identification labels.

Required tools

3 mm screwdriver (only for removing the color identification labels)

Applying color identification labels

Press color-coded labels onto the terminal block of the I/O module.

NOTE

To remove the color identification labels, you must first disconnect the wiring on the I/O module and then carefully lever the color identification labels out of the holder using a screwdriver.

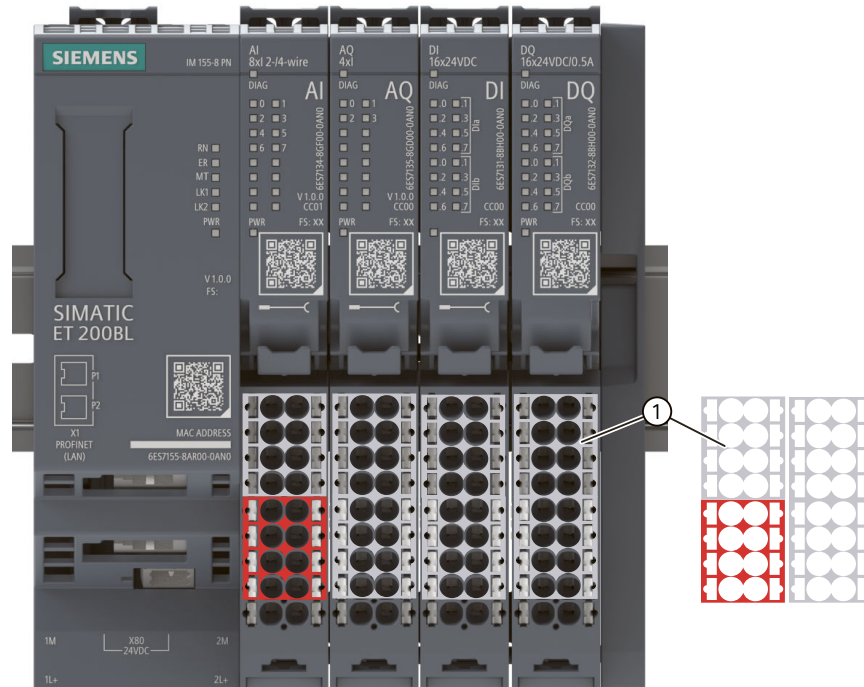

- ① Module-specific color identification labels (15 mm) for the process terminals. You can find additional information in the equipment manual of the I/O module (<https://support.automation.siemens.com/WW/view/en/109987785>).

Figure 7-8 Applying color identification labels (example)

NOTICE

Supply of incorrect potential possible

Check that the color-coded labels/wiring is correct before commissioning the plant.

7.8.4 Applying labeling strips

Procedure

Proceed as follows to install a labeling strip:

1. Label the strips.
2. Insert the labeling strip into the guide slot at the interface module.

7.8.5 Applying reference identification labels

Procedure

Proceed as follows to install a reference identification label:

1. Break off the reference identification labels from the sheet.
2. Insert the reference identification labels into the opening on the interface module or I/O module. The insertion opening is located on the top of the I/O module in each case.

NOTE

Reference identification label

The printable side of the reference identification label must be facing forward.

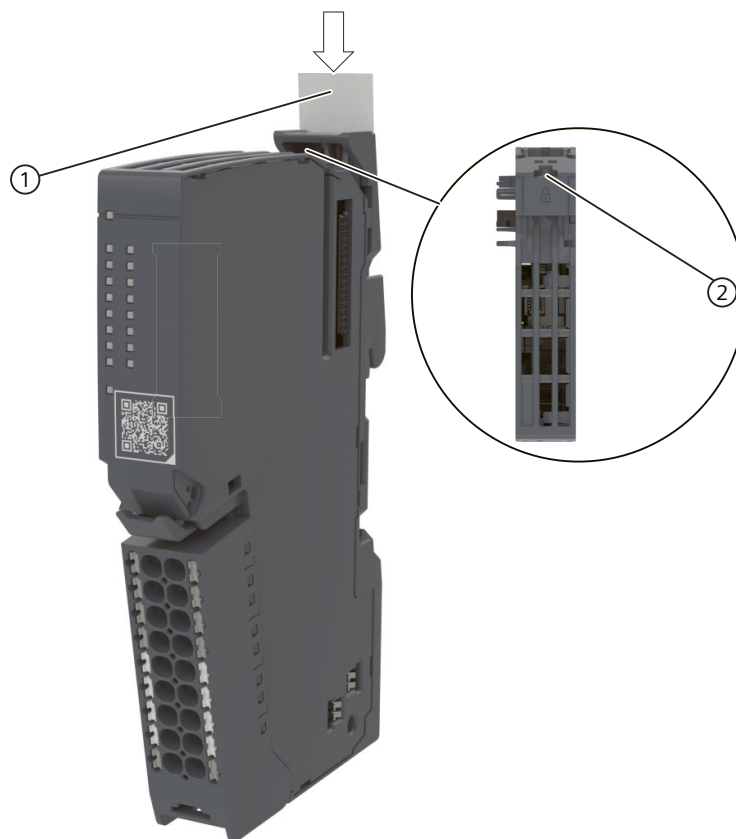

- ① Equipment labeling plate
- ② Opening for label

Figure 7-9 Applying reference identification labels

Configuring

8.1 Configuring ET 200BL

Introduction

You configure and assign parameters to the ET 200BL distributed I/O system with a GSD file for PROFINET (<https://support.industry.siemens.com/cs/ww/en/view/109991113>) in STEP 7 (TIA Portal) as of V18, STEP 7 MicroWIN as of V3.0 or in the configuration software of another manufacturer.

"**Configuring**" is understood to mean the arranging, setup and networking of devices and modules within the device view or network view. STEP 7 graphically represents modules and racks. Just like "real" module racks, the device view allows the insertion of a defined number of modules.

When the modules are inserted, STEP 7 automatically assigns the addresses and a unique hardware identifier (HW identifier). You can change the addresses later. The hardware identifiers cannot be changed.

When the automation system is started, the interface module compares the configured preset configuration with the system's actual configuration. You can make parameter settings to control the response of the interface module to errors in the hardware configuration.

"**Parameterizing**" the components used signifies setting their properties. During parameter assignment, the hardware parameters are set and the settings for data exchange are made:

- Properties of the modules to which parameters can be assigned
- Settings for data exchange between components

STEP 7 compiles the hardware configuration (the result of "configuring" and "assigning parameters") and downloads it to the CPU. The CPU then connects to the configured components and transfers their configuration and parameters. Modules can be replaced very easily because STEP 7 transfers the configuration and parameters when a new module is inserted.

Configuring ET 200BL

See the STEP 7 (TIA Portal), STEP 7 MicroWIN online help or the documentation of the configuration software manufacturer.

8.2 Configuring the interface module

Configuring

Read the online help for STEP 7 (TIA Portal), STEP 7 MicroWIN or the documentation of the configuration software manufacturer when configuring the interface module.

8.3 Substitute value behavior

The substitute value behavior in the ET 200BL distributed I/O system is executed by the IO controller for each I/O module.

If more than 16 I/O modules are plugged or more than the last I/O module is pulled, the station enters STOP mode.

The respective output behaves according to its configured substitute value behavior:

- Current-free/voltage-free
- Output substitute value
- Keep last value

The substitute value behavior is triggered in the following cases:

- STOP controller
- Controller failure (connection interrupted)
- Station stop, e.g. if more than one I/O module is pulled at the end of the station.
- Deactivating the IO device

The "current-free/de-energized" behavior is in effect in the following cases:

- Firmware update
- Reset to factory settings
- Incorrectly configured module
- Module with incorrect parameter assignment

NOTE

Reducing a configuration

If you reduce the configuration of the ET 200BL distributed I/O system and download the configuration to the CPU, the modules which are no longer configured but still present retain their original substitute value behavior. This applies until the supply voltage is switched off at the interface module.

Commissioning

9.1 Overview

Introduction

This section includes information on the following topics:

- Commissioning the ET 200BL distributed I/O system on the PROFINET IO
- Identification and maintenance data

Commissioning requirements

NOTE**Performing tests**

You must ensure the safety of your plant. You therefore need to run a complete functional test and make the necessary safety checks before the final commissioning of a plant.

Also allow for any possible foreseeable errors in the tests. This avoids endangering persons or equipment during operation.

PRONETA

With SIEMENS PRONETA (PROFINET network analysis), you analyze the system network during commissioning. PRONETA features two core functions:

- The topology overview independently scans PROFINET and all connected components.
- The IO check is a fast test of the wiring and the module configuration of a system.

You can find SIEMENS PRONETA on the Internet

(<https://support.automation.siemens.com/WW/view/en/67460624>).

MultiFieldbus Configuration Tool (MFCT)

MultiFieldbus Configuration Tool (MFCT) is PC-based software and supports the configuration of MultiFieldbus-devices. Other devices are supported via plug-ins (e.g. DALI and Siwarex). In addition, the MFCT offers convenient options for bulk firmware update of ET 200 devices with MultiFieldbus-support and reading of service data for many other Siemens devices.

You can find MFCT on the Internet

(<https://support.industry.siemens.com/cs/ww/en/view/109773881>).

9.2 Commissioning ET 200BL on PROFINET IO

Requirements

The interface module is in the "Factory settings" status or has been reset to factory settings (see section Resetting interface module (PROFINET IO) to factory settings [\(Page 87\)](#)).

9.2.1 ET 200BL as IO device

Configuration example

You need the IM 155-8 PN interface module to use the ET 200BL distributed I/O system as an IO device.

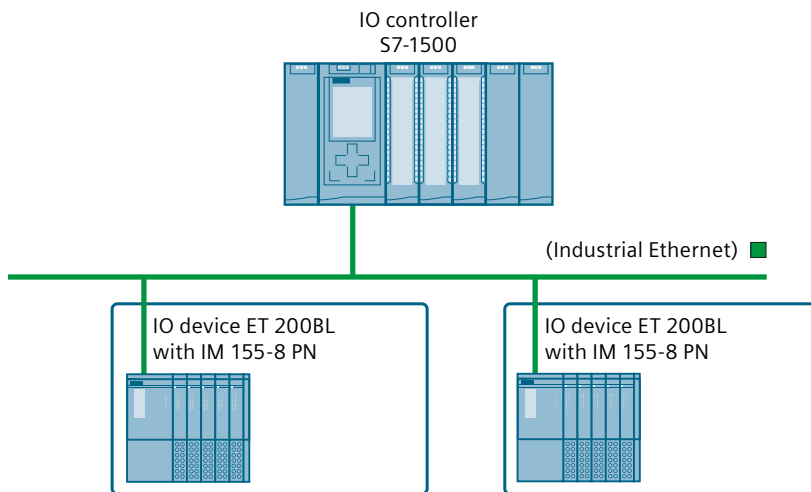

Figure 9-1 ET 200BL as an IO device

Commissioning procedure

For commissioning of the ET 200BL distributed I/O system as an IO device on the PROFINET IO, we recommend the following procedure:

Table 9-1 Procedure for commissioning ET 200BL as an IO device on PROFINET IO

Step	Procedure	See ...
1	Installing ET 200BL	Section Installation (Page 43)
2	Connecting ET 200BL <ul style="list-style-type: none"> • Supply voltages • PROFINET IO • Sensors and actuators 	Section Wiring (Page 54)
4	Configuring IO controller	Documentation of the IO controller
5	Checking the protective measures	-
6	Switching on supply voltages for the IO controller	Documentation of the IO controller

Step	Procedure	See ...
7	Switching on supply voltages for IO devices	Interface module (https://support.automation.siemens.com/WW/view/en/109987777) Manual
8	Downloading the configuration to the IO controller	STEP 7 online help
9	Switching IO controller to RUN mode	Documentation of the IO controller
10	Checking LEDs	Interface module (https://support.automation.siemens.com/WW/view/en/109987777) Manual
11	Testing inputs and outputs	The following functions are helpful: Monitoring and modifying tags, testing with program status, forcing, controlling the outputs.

9.3 Identification and maintenance data

9.3.1 Reading out and entering I&M data

I&M data

Identification and maintenance data (I&M data) is information saved on the module. The data is:

- Read-only (I-data) or
- Readable/writable (M-data)

Identification data (I&M0): Manufacturer information about the module that can only be read. Some identification data is also printed on the housing of the module, for example article number and serial number.

Maintenance data (I&M1, 2, 3): Plant-dependent information, e.g. installation location. Maintenance data is created during configuration and downloaded to the module. All modules of the ET 200BL distributed I/O system support identification data (I&M0 to I&M3).

The I&M identification data supports you in the following activities:

- Checking the plant configuration
- Locating hardware changes in a plant
- Correcting errors in a plant

Modules can be clearly identified online using the I&M identification data.

Options for reading out I&M data

- Via the user program
- Via STEP 7 or HMI devices
- Via the CPU web server

Reading I&M data via the user program

You have the following options to read the modules' I&M data in the user program:

- Using the RDREC instruction
The data record structure for distributed modules that are accessible via PROFINET IO, is described in the section Record structure for I&M data [\(Page 79\)](#).
- Using the Get_IM_Data instruction

Reference

You can find the description of the instructions in the STEP 7 (TIA Portal) online help.

Reading I&M data via STEP 7 (TIA Portal)

Requirements: There must be an online connection to the interface module.

To read I&M data using STEP 7 (TIA Portal), follow these steps:

1. Under "Distributed I/O" in the project tree, select the IO device IM 155-8 PN, for example.
2. Select **> IO device > Online & diagnostics > Identification & Maintenance**.

Entering maintenance data via STEP 7 (TIA Portal)

STEP 7 (TIA Portal) assigns a default module name. You can enter the following information:

- Plant designation (I&M1)
- Location identifier (I&M1)
- Installation date (I&M2)
- Additional information (I&M3)

To enter maintenance data via STEP 7, follow these steps:

1. In the device view of the STEP 7 hardware network editor, select the interface module, for example.
2. In the properties under "General", select the "Identification & Maintenance" area and enter the data.

During the loading of the hardware configuration, the I&M data is also loaded.

Procedure for reading I&M data via the Web server

The procedure is described in detail in the Web server

(<https://support.automation.siemens.com/WW/view/en/59193560>) Function Manual.

9.3.2 Data record structure for I&M data

Reading I&M records via the user program (distributed via PROFINET IO)

You directly access specific identification data using **Read data record** ("RDREC" instruction). You obtain the corresponding part of the identification data under the relevant data record index.

The data records are structured as follows:

Table 9-2 Basic structure of data records with I&M identification data

Content	Length (bytes)	Coding (hex)
Header information		
BlockType	2	I&M0: 0020 _H I&M1: 0021 _H I&M2: 0022 _H I&M3: 0023 _H
BlockLength	2	I&M0: 0038 _H I&M1: 0038 _H I&M2: 0012 _H I&M3: 0038 _H
BlockVersionHigh	1	01
BlockVersionLow	1	00
Identification data		
Identification data (see table below)	I&M0/index AFF0 _H : 54 I&M1/index AFF1 _H : 54 I&M2/index AFF2 _H : 16 I&M3/index AFF3 _H : 54	

Table 9-3 Data record structure for I&M identification data

Identification data	Access	Default setting	Explanation
Identification data 0: (data record index AFF0 hex)			
VendorIDHigh	Read (1 byte)	00 _H	This is where the name of the manufacturer is stored (42 _D = SIEMENS AG).
VendorIDLow	Read (1 byte)	2A _H	
Order_ID	Read (20 bytes)	6ES7155-8AR00-0AN0	Article number of the module (e.g. of the IM 155-8 PN interface module)
IM_SERIAL_NUMBER	Read (16 bytes)	-	Serial number (device-specific)
IM_HARDWARE_REVISION	Read (2 bytes)	1	Corresponding HW version
IM_SOFTWARE_REVISION	Read	Firmware version	Provides information about the firmware version of the module
• SWRevisionPrefix	(1 byte)	V	
• IM_SWRevision_Functional_Enhancement	(1 byte)	00 - FF _H	
• IM_SWRevision_Bug_Fix	(1 byte)	00 - FF _H	

9.3 Identification and maintenance data

Identification data	Access	Default setting	Explanation
• IM_SWRevision_Internal_Change	(1 byte)	00 - FF _H	Provides information about the firmware version of the module
IM_REVISION_COUNTER	Read (2 bytes)	0000 _H	Provides information about parameter changes on the module (not used)
IM_PROFILE_ID	Read (2 bytes)	0000 _H	Generic Device
IM_PROFILE_SPECIFIC_TYPE	Read (2 bytes)	0005 _H	Interface modules
		0003 _H	I/O modules
		0001 _H	CPU
IM_VERSION	Read	0101 _H	Provides information on the version of the identification data (0101 _H = Version 1.1)
• IM_Version_Major	(1 byte)		
• IM_Version_Minor	(1 byte)		
IM_SUPPORTED	Read (2 bytes)	000E _H	Provides information about the available identification data (I&M1 to I&M3)
Maintenance data 1: (data record index AFF1 hex)			
IM_TAG_FUNCTION	Read/write (32 bytes)	-	Enter a module identifier here that is unique plant-wide.
IM_TAG_LOCATION	Read/write (22 bytes)	-	Enter the installation location of the module here.
Maintenance data 2: (data record index AFF2 hex)			
IM_DATE	Read/write (16 bytes)	YYYY-MM-DD HH:MM	Enter the installation date of the module here.
Maintenance data 3: (data record index AFF3 hex)			
IM_DESCRIPTOR	Read/write (54 bytes)	-	Enter a comment describing the module.

Maintenance

10.1 Removing and inserting I/O modules

Requirement

Pull or plug I/O modules only when the voltage is switched off. Proceed as described in section Installing/removing I/O modules [\(Page 50\)](#).

NOTE

If you pull or plug more than the last permitted I/O module of the station, the station switches to STOP.

NOTICE
<p>Physical damage can occur</p> <p>If you install or uninstall I/O modules with switched-on voltage, this can lead to undefined conditions in your plant.</p> <p>The ET 200BL distributed I/O system may be damaged as a result.</p> <p>Only install/remove the I/O module when the power supply is disconnected.</p> <p>Therefore during the planning of a plant always make sure to comply with the necessary, pertinent standards and safety guidelines.</p>

10.2 Exchanging the terminal block

Introduction

The terminal block is a component of the I/O module. If required, you can replace the terminal block. You do not need to uninstall the I/O module or the ET 200BL station to do this. The load current supply bus of the potential group is not interrupted while the terminal block is being replaced.

Requirements

- The I/O module is installed and wired.

 WARNING
Hazardous voltage Hazardous electrical voltage can cause electric shock, burns and property damage. Disconnect your system and devices from the power supply before starting any assembly tasks.

Procedure

To exchange the terminal block on a I/O module, proceed as follows:

1. Switch off any existing supply voltage on the I/O module.
2. Disconnect the wiring on the terminal block.
3. Press the release mechanism down with your finger or a screwdriver. The release mechanism of the terminal block is located on the top of the terminal block.

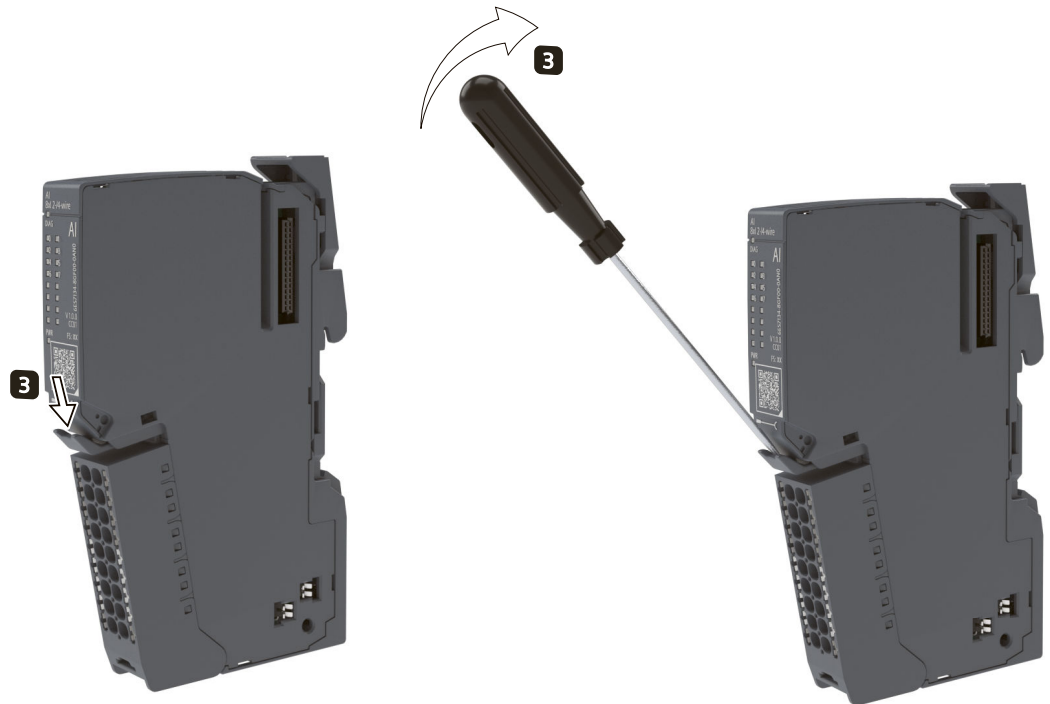

4. Tilt the released terminal block forward.
5. Pull the terminal block out of the I/O module.

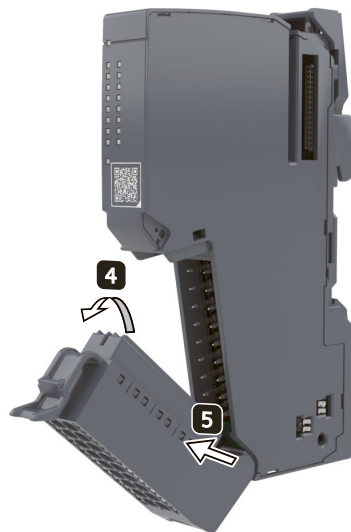

6. Insert the new terminal block into the I/O module.

7. Swivel the new terminal block to the rear into the I/O module until the terminal block latches into place.

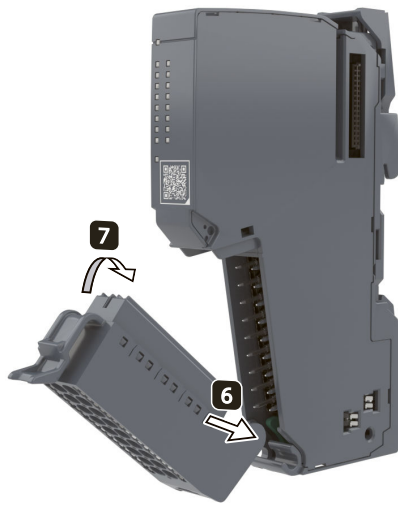

8. Wire the terminal block.
9. Switch on any existing supply voltage on the I/O module.

10.3 Firmware update

Introduction

During operation it may be necessary to update the firmware (e.g. to extend the available functions).

Update the firmware of the interface module and I/O modules using firmware files. The retentive data is retained after the firmware has been updated.

We recommend that you always update to the latest firmware version available for the respective article number. The previous versions of the firmware are only foreseen as a backup to enable you to downgrade to the original version.

Requirement

- You have downloaded the file(s) for the firmware update from the Product Support (<https://sieportal.siemens.com/su/blouZ>) web page.
 - Select "ET 200BL" in the master tree on the left-hand side on this web page.
 - From this position, navigate to the specific type of module that you want to update. To continue, click on the "Software downloads" link under "Support". Save the desired firmware update files.
- Before installing the firmware update, make sure that the modules are not being used.

NOTE

Firmware update of I/O modules

The L+ supply voltage must be present on the module at the start of and during the firmware update.

Options for the firmware update

The following options are available for updating firmware:

- Online in STEP 7 (TIA Portal) via Online & Diagnostics
- Online in STEP 7 (TIA Portal) via accessible devices (PROFINET)
- Online with the MultiFieldbus Configuration Tool (MFCT) (<https://support.industry.siemens.com/cs/ww/en/view/109781837>)

Online procedure in STEP 7 (TIA Portal) via Online & Diagnostics

Requirements: There is an online connection between the CPU/module and PG/PC.

Proceed as follows to perform a firmware update online using STEP 7 (TIA Portal):

1. Select the module in the device view.
2. Select the "Online & diagnostics" command from the shortcut menu.
3. Select the "Firmware update" group in the "Functions" folder.
4. Click the "Browse" button to select the path to the firmware update files in the "Firmware update" area.
5. Select the suitable firmware file. The table in the firmware update area lists all modules for which an update is possible with the selected firmware file.
6. Click the "Run update" button. If the module can interpret the selected file, the file is downloaded to the module.

Updating the firmware

The "Run firmware after update" check box is always selected.

When the loading process is complete, the module adopts the firmware and then operates with this new firmware.

NOTE

If a firmware update is interrupted, you need to remove and insert the module before starting the firmware update again.

Installation of the firmware update

 **WARNING**

Risk of impermissible system states

The interface module changes to the station failure state as a result of the firmware update being installed. Station failure can have an effect on the operation of an online process or a machine.

Unexpected operation of a process or a machine can lead to fatal or severe injuries and/or to material damage.

Make sure that the interface module is not executing any active process before installing the firmware update.

Online procedure in STEP 7 (TIA Portal) via accessible devices

To perform a firmware update online via accessible devices, follow these steps:

1. From the "Online" menu, select the "Accessible devices" menu item.
2. In the "Accessible devices" dialog, search for the accessible devices for the selected PROFINET interface.
3. To go to a device in the project tree, select the desired device from the list of accessible devices and click the "Show" button.
4. In the project tree, select the "Online & diagnostics" option of the relevant device and perform the firmware update under the category "Functions/Firmware update" (interface module, local modules).

Behavior during the firmware update

Note the following behavior of the relevant I/O module when carrying out a firmware update:

- The DIAG LED display flashes red.
- The I/O module retains its current diagnostic status.
- Diagnostics alarm: Channel temporarily unavailable (error code 31_D/1F_H)
- All outputs are in a current-free/voltage-free state

Behavior after the firmware update

After the firmware update, check the firmware version of the updated module. The new firmware only becomes active after the reboot of the module.

Reference

You can find more information on these procedures in the STEP 7 (TIA Portal) online help.

10.4 Resetting interface module (PROFINET IO) to factory settings

Function

The "Reset to factory settings" function returns the interface module to its delivery state.

Reset options

- Via STEP 7 (TIA Portal) (online via PROFINET IO)
- Online with the MultiFieldbus Configuration Tool (MFCT)
(<https://support.industry.siemens.com/cs/ww/enb/view/109781837>)

Procedure with STEP 7 (TIA Portal)

To reset an interface module to factory settings using STEP 7 (TIA Portal), follow these steps:

Make sure that an online connection to the interface module exists and that the interface module is not connected to a CPU.

1. Open the online and diagnostics view of the interface module.
2. In the "Functions" folder, select the "Reset to factory settings" group.
3. Click the "Reset" button.
4. Click "OK" in response to the confirmation prompt.

Result: The interface module then performs "Reset to factory settings".

Result after resetting to factory settings

The following table shows the values of the interface module properties after a factory reset:

Table 10-1 Properties of the interface module as shipped

Properties	Value
Parameters	Default setting
IP address	Not available
Device name	Not available
MAC address	Available
I&M data	Identification data (I&M0) available Maintenance data (I&M1, 2, 3) reset
Firmware version	Available

NOTE

Failure of downstream stations is possible

Downstream stations on a bus segment can fail when the factory settings are restored on an interface module.

NOTE

Behavior of the installed I/O modules during reset to factory settings

The I/O modules of the ET 200BL distributed I/O system assume the unconfigured state after a "reset to factory settings". The interface module does not acquire any input data and does not output any output data.

Reference

You will find more information on the procedure in the STEP 7 online help.

10.5 Maintenance and repair

The components of the ET 200BL distributed I/O system are maintenance-free.

NOTE

Repairs to the SIMATIC ET 200BL system may not be carried out.

NOTE

Cleaning the ET 200BL

Requirement: All supply voltages on the ET 200BL distributed I/O system are switched off. Observe the five safety rules for working in and on electrical installations.

If you need to clean the devices, use dry ESD cleaning cloths (observing the ESD protective measures).

10.6 Warranty

To meet the conditions of the warranty, you must observe the safety and commissioning instructions.

Technical specifications

11.1 Introduction

Introduction

This chapter lists the technical specifications of the system:

- The standards and test values that the ET 200BL distributed I/O system complies with and fulfills.
- The test criteria according to which the ET 200BL distributed I/O system was tested.

Technical specifications of the modules

The technical specifications of the individual modules can be found in the manuals for the relevant modules. In the event of deviations between the statements in this document and the manuals, the statements in the manuals take priority.

11.2 Safety information

Safety of the plant or the system

NOTICE
Safety is the responsibility of the assembler
The safety of any plant or system incorporating the equipment is the responsibility of the assembler of the plant or system.

11.3 Marks and approvals

Marks and approvals on the nameplate

The following overview provides information about the possible marks and approvals. Only the marks and approvals specified on the nameplate apply to the device.

You can find the associated certificates for download on the Internet (<https://sieportal.siemens.com/su/blYHN>).

CE marking



The ET 200BL distributed I/O system meets the requirements and protection targets of the following directives. The distributed I/O system complies with the harmonized European standards (EN) for programmable logic controllers published in the official journals of the European Union.

- 2014/30/EU "Electromagnetic Compatibility" (EMC Directive)
- 2011/65/EU "Restriction of the use of certain hazardous substances in electrical and electronic equipment" (RoHS Directive)

The EU Declarations of Conformity are available for the responsible authorities and are kept at the following address:

Siemens Aktiengesellschaft
Digital Industries
Factory Automation
DI FA TI COS TT
P.O. Box 1963
D-92209 Amberg, Germany

You can also find the EU Declarations of Conformity on the Internet (<https://sieportal.siemens.com/su/blYHV>).

UK Conformity Assessed marking



The ET 200BL distributed I/O system complies with the designated British standards (BS) for programmable logic controllers published in the official consolidated list of the British Government. The ET 200BL distributed I/O system meets the requirements and protection targets of the following regulations and associated supplements:

- Electromagnetic Compatibility Regulations 2016 (S.I. 2016 No. 1091), and related amendments
- Restriction of the Use of Certain Hazardous Substances in Electrical and Electronic Equipment Regulations 2012 (S.I. 2012 No. 3032), and related amendments

The UK Declarations of Conformity are available to the relevant authorities at the following address:

Siemens Aktiengesellschaft
Digital Industries
Factory Automation
DI FA TI COS TT

P.O. Box 1963
D-92209 Amberg, Germany

You can also find the UK Declarations of Conformity on the Internet
(<https://sieportal.siemens.com/su/blYH0>).

cULus approval



Underwriters Laboratories Inc.:

- UL 61010-1 and UL 61010-2-201
- CAN/CSA C22.2 No. 142 (Process Control Equipment) OR CAN/CSA C22.2 No. 61010-1 and CAN/CSA C22.2 No. 61010-2-201

RCM Australia/New Zealand



The ET 200BL distributed I/O system meets the requirements of EN 61000-6-4 Generic standards – Emission standard for industrial environments.

Korea Certificate



Note that this device conforms to Limit Class A for emission of radio interference. This device is not intended to be used in residential areas.

이 기기는 업무용(A급) 전자파 적합기기로서 판매자 또는 사용자는 이 점을 주의하시기 바라며 가정 외의 지역에서 사용하는 것을 목적으로 합니다.

11.4 Standards and requirements

The ET 200BL distributed I/O system meets the following standards and requirements.

IEC 61131-2

The ET 200BL distributed I/O system fulfills the requirements and criteria of the standard IEC 61131-2 (Programmable controllers, Part 2: Equipment requirements and tests) and the EMC requirements for use in Zone B.

IEC 61010-2-201

The ET 200BL distributed I/O system fulfills the requirements and criteria of standard IEC 61010-2-201 (Safety requirements for electrical equipment for measurement, control, and laboratory use Part 2-201: Particular requirements for control equipment).

IEC 60695-11-10

The ET 200BL distributed I/O system fulfills the requirements and criteria of the standard IEC 60695-11-10 (Fire hazard testing - Part 11-10: Test flames - 50 W horizontal and vertical flames test methods).

UL 94

The ET 200BL distributed I/O system fulfills the requirements and criteria of the standard UL 94 (Tests for Flammability of Plastic Materials for Parts in Devices and Appliances).

PROFINET

The PROFINET interfaces of the ET 200BL distributed I/O system are based on the standard IEC 61158 Type 10.

Use in industrial environments

The ET 200BL distributed I/O system is designed for use in industrial areas. It meets the following standards for this type of use:

- Requirements on interference emission EN 61000-6-4: 2007 + A1
- Requirements for immunity EN 61000-6-2

Use in mixed areas

Under certain circumstances, you can use the ET 200BL distributed I/O system in a mixed area. A mixed area is used for residential purposes and for commercial operations that do not significantly impact the residential purpose.

If you want to use the ET 200BL distributed I/O system in mixed areas, you must ensure that its radio frequency interference emission complies with the limit classes of the EN 61000-6-3 generic standard. Suitable measures for observing these limits for use in a mixed area are, for example:

- Installation of the ET 200BL distributed I/O system in grounded control cabinets
- Use of filters in the supply lines

An additional individual acceptance test is also required.

Use in residential areas

The ET 200BL distributed I/O system is **not** intended for use in residential areas. Using the ET 200BL distributed I/O system in residential areas may affect radio or television reception.

Environmental Product Declaration (EPD)

Siemens is committed to the development and production of environmentally compatible and sustainably produced equipment.

With the help of an Environmental Product Declaration (EPD), you can obtain information on the "ecological footprint" of your Siemens product.

The EPD is based on the international ISO 14021 standard "Environmental labels and declarations – Self declared environmental claims – Type II".

EPDs are based on independently verified data from life cycle assessments, life cycle inventory analyses and information modules that comply with the ISO 14040 series of standards. The EPD contains comprehensive data relating to ingredients and substances (REACH, RoHS), fire load, energy consumption, packaging and disposal information for your Siemens product.

You can find the current Environmental Product Declarations (EPDs) for the ET 200BL distributed I/O system on the Internet (<https://sieportal.siemens.com/su/bloYS>).

Importer addresses

The following table shows the importer addresses for specific countries:

Countries	Address
United Kingdom (UK)	Siemens plc. Manchester M20 2UR
Türkiye (TR)	Siemens San. ve Tic. A.Ş. Yakacık Cad. No: 111 34870 Kartal/İstanbul

11.5 Electromagnetic compatibility

Definition

Electromagnetic compatibility (EMC) is the ability of an electrical installation to function satisfactorily in its electromagnetic environment without interfering with that environment.

The ET 200BL distributed I/O system meets the legal requirements for electromagnetic compatibility of equipment. The prerequisite is that the ET 200BL distributed I/O system complies with the requirements and guidelines relating to electrical equipment.

Pulse-shaped disturbance variables of the ET 200BL system

The table below shows the electromagnetic compatibility of the ET 200BL distributed I/O system with regard to pulse-shaped disturbance variables.

Table 11-1 Pulse-shaped disturbance variables

Pulse-shaped disturbance variable	Tested with	Equivalent to severity
Electrostatic discharge in accordance with IEC 61000-4-2 *)	Air discharge: ± 2 kV, ± 4 kV, ± 8 kV	3
	Contact discharge: ± 4 kV	3
Burst pulses (fast transient interference) in accordance with IEC 61000-4-4 *)	± 2 kV (power supply line)	3
	± 2 kV (signal line >30 m)	4
	± 1 kV (signal line <30 m)	3
High-energy single pulse (surge) in accordance with IEC 61000-4-5 **)		
• Asymmetric coupling (line to ground) ***)	± 1 kV (24 V DC supply cable)	2
	± 1 kV (24 V DC signal line/data cable)	2
	± 2 kV (shielding of the signal lines)	3
• Symmetric coupling (line to line) ***)	± 0.5 kV (24 V DC supply cable)	2
*) The maximum short-term influence of analog modules during the duration of the EMC tests can be $\pm 10\%$ of the full-scale value. **) Analog value deviation beyond the limits of the nominal range and diagnostics possible. ***) If higher line to ground or line to line values are required, you will need an additional external protective circuit (see Designing interference-free controllers https://support.automation.siemens.com/WW/view/en/59193566 Function Manual).		

Sinusoidal disturbance variables

The tables below show the electromagnetic compatibility of the ET 200BL distributed I/O system with regard to sinusoidal disturbance variables.

- RF radiation

RF radiation in accordance with IEC 61000-4-3 Electromagnetic RF field, amplitude-modulated		Corresponds to degree of severity
80 MHz to 1 GHz	10 V/m	3
1.4 GHz to 6 GHz	3 V/m	2
80% AM (1 kHz)		

- RF coupling

RF coupling in accordance with IEC 61000-4-6		Corresponds to degree of severity
150 kHz to 80 MHz		3
10 V _{rms} unmodulated		
80% AM (1 kHz)		
150 Ω source impedance		

The maximum short-term influence of analog modules during the duration of the EMC tests can be ±1% of the full-scale value.

Emission of radio frequency interference

Interference emission of electromagnetic fields in accordance with IEC 61000-6-4.

Table 11-2 Interference emission of electromagnetic fields

Frequency	Interference emission	Measuring distance
30 MHz to 230 MHz	<50 dB (μV/m) Q	3 m
230 MHz to 1000 MHz	<57 dB (μV/m) Q	3 m
1 GHz to 3 GHz	<76 dB (μV/m) P; <56 dB (μV/m) A	3 m
3 GHz to 6 GHz	<80 dB (μV/m) P; <60 dB (μV/m) A	3 m

Interference emission via DC power supply in accordance with IEC 61000-6-4.

Table 11-3 Interference emission via DC power supply

Frequency	Interference emission
0.15 MHz to 0.5 MHz	<79 dB (μV) Q <66 dB (μV) M
0.5 MHz to 30 MHz	<73 dB (μV) Q <60 dB (μV) M

11.6 Shipping and storage conditions

Introduction

The ET 200BL distributed I/O system meets the requirements in terms of shipping and storage conditions according to IEC 61131-2. The following information applies to modules that are shipped and/or stored in their original packaging.

Table 11-4 Shipping and storage conditions for modules

Type of condition	Permissible range
Free-fall (in shipping package)	≤ 0.3 m
Temperature	From -40 °C to +70 °C
Barometric pressure	from 1140 to 540 hPa (corresponds to an altitude of -1000 to 5000 m)
Relative humidity	5% to 95%, without condensation
Sinusoidal oscillations according to IEC 60068-2-6	5 - 8.4 Hz: 3.5 mm 8.4 - 500 Hz: 9.8 m/s ²
Impact according to IEC 60068-2-27	250 m/s ² , 6 ms, 1000 shocks

11.7 Mechanical and climatic environmental conditions

Operating conditions

The ET 200BL distributed I/O system is intended for weather-protected, stationary use. The operating conditions are based on the requirements of IEC 61131-2.

- OTH4 (Minimum ambient temperature, see the Climatic ambient temperatures table)
- STH4 (Minimum ambient temperature -40 °C, minimum relative humidity 5%)
- TTH4 (Minimum relative humidity 5%)

Mechanical environmental conditions

The following table shows the mechanical environmental conditions in the form of sinusoidal vibrations.

Table 11-5 Mechanical environmental conditions

Frequency band	ET 200BL
5 ≤ f ≤ 8.4 Hz	3.5 mm amplitude
8.4 ≤ f ≤ 150 Hz	1 g constant acceleration

Tests of mechanical environmental conditions

The following table provides important information with respect to the type and scope of the tests of environmental mechanical conditions.

Table 11-6 Tests of mechanical environmental conditions

Condition tested	Test standard	Comment
Vibrations	Vibration test according to IEC 60068-2-6 (sinusoidal)	Type of vibration: Frequency sweeps with a rate of change of 1 octave/minute. Duration of vibration: 10 frequency sweeps per axis at each of three vertically aligned axes
Shock	Shock, tested according to IEC 60068-2-27	Type of shock: Half-sine Shock intensity: 15 g peak value, 11 ms duration Direction of shock: 3 shocks in each direction (+/-) at each of three vertically aligned axes

Climatic environmental conditions

The following table shows the permissible climatic ambient conditions for the ET 200BL distributed I/O system during operation.

Table 11-7 Climatic environmental conditions

Environmental conditions	Permissible range	Comments
Temperature: horiz. mounting position: vertical mounting position:	-30 °C to 60 °C -30 °C to 50 °C	For the ET 200BL system, the lower permissible ambient temperature was extended to -30 °C. Differences may exist for specific modules and depending on the mounting position and, if applicable, load. Detailed information on this is described in the technical specifications of the respective equipment manual. The product data sheets with daily updated technical specifications can be found on the Internet (https://support.industry.siemens.com/cs/ww/en/ps/td) at Industry Online Support. Enter the article number or the short description of the desired module on the website.
Permitted temperature change	10 K/h	-
Relative humidity	from 10 to 95%	Without condensation or icing.
Barometric pressure	from 1140 to 795 hPa	Corresponds to an altitude of -1000 to 2000 m. Note the following section "Using the ET 200BL distributed I/O system more than 2000 m above sea level".
Pollutant concentration	ANSI/ISA-71.04 severity level G1; G2; G3	-

Using the ET 200BL distributed I/O system more than 2000 m above sea level

The maximum "operating altitude above sea level" depends on the module and is described in the technical specifications of the respective module. The product data sheets with daily updated technical specifications can be found on the Internet

(<https://support.industry.siemens.com/cs/ww/en/ps/td>) at Industry Online Support. Enter the article number or the short description of the desired module on the website.

For altitudes > 2000 m, the following constraints apply to the maximum specified ambient temperature:

Restrictions of the specified maximum ambient temperature in reference to the installation altitude

Installation altitude	Derating factor for ambient temperature ¹⁾
-1000 m to 2000 m	1.0
2000 m to 3000 m	0.9
3000 m to 4000 m	0.8
4000 m to 5000 m	0.7

¹⁾ Base value for application of the derating factor is the maximum permissible ambient temperature in °C for 2000 m.

NOTE

- Linear interpolation between altitudes is permissible.
- The derating factors compensate for the decreasing cooling effect of air at higher altitudes due to lower density.
- Note the mounting position of the respective module in the technical specifications. This is based on the IEC 61131-2 standard.
- Make sure that the power supplies used are suitable for altitudes > 2000 m.

11.8 Insulation, protection class, degree of protection and rated voltage

Insulation

The insulation for the I/O modules is dimensioned according to the requirements of the IEC 61010-2-201.

NOTE

For modules with 24 V DC supply voltage (SELV), galvanic isolation is tested with 707 V DC (type test).

Severity for voltage interruption according to IEC 61131-2

Interface modules meet the severity class PS1 for voltage interruptions (1 ms).

Pollution degree/overvoltage category in accordance with IEC 61131-2 and IEC 61010-2-201

- Pollution degree 2
- Overvoltage category: II

Protection class according to IEC 61010-2-201

The ET 200BL distributed I/O system complies with protection class III.

The grounding of the mounting rail must meet the requirements for a functional earth FE.

Recommendation: For an interference-proof installation, the ground conductor should have a cross-section $> 6 \text{ mm}^2$.

The installation location (e.g. enclosure, control cabinet) must have a protective conductor connection that meets the standard to maintain protection class I.

Degree of protection IP20

Degree of protection IP20 according to IEC 60529 for all modules of the ET 200BL distributed I/O system, which means:

- Protection against contact with standard probes
- Protection against foreign objects with diameters in excess of 12.5 mm
- No protection against water

Rated voltage for operation

The ET 200BL distributed I/O system works with the rated voltage and corresponding tolerances listed in the following table.

Note the supply voltage of each module when selecting the rated voltage.

Table 11-8 Rated voltage for operation

Rated voltage	Tolerance range
24 V DC	20.4 V DC to 28.8 V DC ¹⁾

¹⁾ Static value: Generation as protective extra-low voltage with safe electrical isolation in accordance with IEC 61131-2 and IEC 61010-2-201

CAUTION

Use copper cables on connectors with terminal connections

Use only copper cables (Cu) for all signal and supply lines that are connected to the device via terminals, e.g. 24 V DC power supply cable to the 24 V DC power supply connections.

Dimension drawings

A.1 Labeling strip

Dimension drawing of the labeling strips (roll)

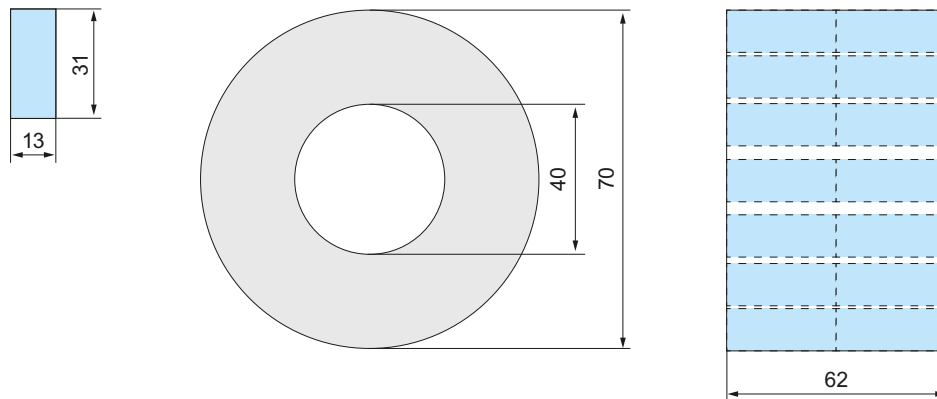

Figure A-1 Dimension drawing of the labeling strips (roll)

Dimension drawing of the labeling strips (DIN A4 sheet)

The product information for the labeling strips (DIN A4 sheets) is available for download on the Internet

(<https://mall.industry.siemens.com/mall/en/de/Catalog/Product/6ES7193-6LA10-0AA0>).

A.2 Reference identification labels

Dimensional diagram of reference identification label and sheet

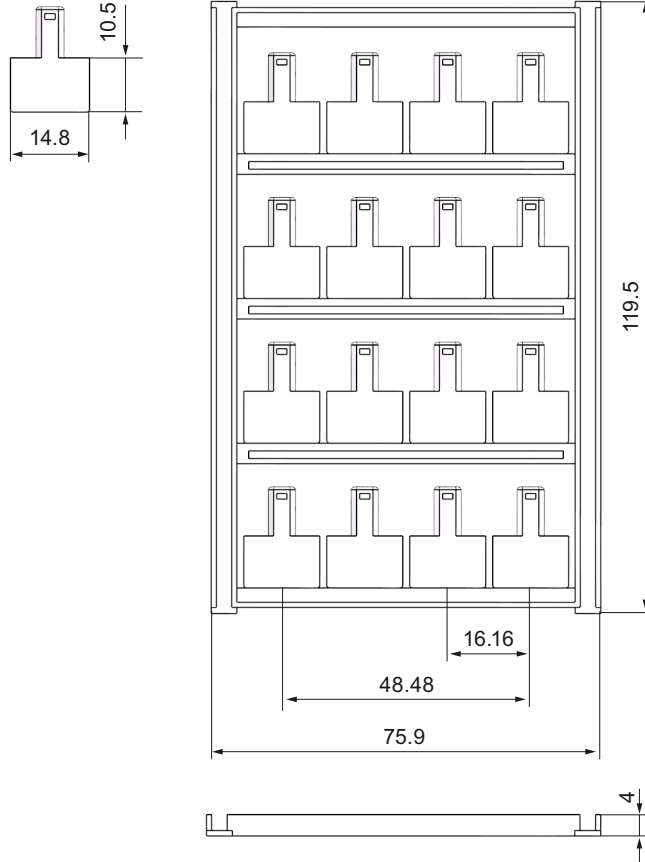

Figure A-2 Dimensional diagram of reference identification label and sheet

Accessories/spare parts

Accessories for the ET 200BL distributed I/O system

Table B-1 Accessories, general

Accessories, general	Packing unit	Article number
24 V DC connector (spare part)	10 units	6ES7193-4JB00-0AA0
Terminal Block 24V	5 units	6ES7193-8ST00-1AN0
End cover	5 Units	6ES7193-8SE00-1AB0
Reference identification label, sheet with 16 labels	10 units	6ES7193-6LF30-0AW0
Labeling strips (for labeling the interface modules)		
<ul style="list-style-type: none"> Roll, light gray labeling strips (with a total of 500 strips), film, for labeling with thermal transfer roll printer 	1 unit	6ES7193-6LR10-0AA0
<ul style="list-style-type: none"> DIN A4 sheets, light gray labeling strips (with a total of 1000 labels), paper, perforated, for labeling with laser printer 	10 units	6ES7193-6LA10-0AA0
DIN rails 35 mm, tinned steel strip ¹⁾		
<ul style="list-style-type: none"> Length: 483 mm 	1 unit	6ES5710-8MA11
<ul style="list-style-type: none"> Length: 530 mm 	1 unit	6ES5710-8MA21
<ul style="list-style-type: none"> Length: 830 mm 	1 unit	6ES5710-8MA31
<ul style="list-style-type: none"> Length 2000 mm 	1 unit	6ES5710-8MA41
SIMATIC system rails ¹⁾		
<ul style="list-style-type: none"> Length 483 mm 	1 unit	6ES7193-6MR00-0AA0
<ul style="list-style-type: none"> Length 530 mm 	1 unit	6ES7193-6MR00-0BA0
<ul style="list-style-type: none"> Length 830 mm 	1 unit	6ES7193-6MR00-0CA0
<ul style="list-style-type: none"> Length 2000 mm 	1 unit	6ES7193-6MR00-0DA0

¹⁾ The length of the DIN rails and SIMATIC system rails can be shortened as required.

Table B-2 Accessories, color identification labels (push-in terminals), 15 mm wide

Accessories, color identification labels (push-in terminals), 15 mm wide	Packing unit	Article number
16 process terminals (see I/O module manual)		
<ul style="list-style-type: none"> Gray (terminals 1 to 16); color code CC00 	10 units	6ES7193-6CP00-2MA0
<ul style="list-style-type: none"> Gray (terminals 1 to 8), red (terminals 9 to 16); color code CC01 	10 units	6ES7193-6CP01-2MA0
<ul style="list-style-type: none"> Gray (terminals 1 to 8), red (terminals 9 to 16); color code CC01 	50 units	6ES7193-6CP01-4MA0

Components for lightning protection

If you need surge protection devices for lightning protection, you can find additional information in the function manual Designing interference-free controllers (<https://support.automation.siemens.com/WW/view/en/59193566>).

Online catalog

Other article numbers for the ET 200BL distributed I/O system can be found on the Internet (<https://mall.industry.siemens.com>) in the online catalog and the online order system.

Calculating the leakage resistance

Introduction

If you wish to protect an ET 200BL station using ground-fault monitoring or a residual current circuit breaker, then you need the leakage resistance to select the correct safety components.

Ohmic resistance

When determining the leakage resistance of the ET 200BL station, you need to take into account the ohmic resistance from the RC combination of the module in question:

Table C-1 Ohmic resistance

Module	Ohmic resistance from RC network
Interface module	10 MΩ (±5 %)
I/O module	10 MΩ (±5 %)

Formula

You can calculate the leakage resistance of the ET 200BL station using the following formula if you protect all of the modules listed above with one ground-fault monitoring:

$$\begin{aligned}
 R_{\text{ET 200BL}} &= R_{\text{module}} / N = \text{Leakage resistor of the ET 200BL station} \\
 R_{\text{module}} &= \text{Leakage resistance of a module} \\
 R_{\text{IM}} &= R_{\text{module}} = 9.5 \text{ M}\Omega = \text{Leakage resistance of the interface module} \\
 N &= \text{Number of I/O modules and interface module in the ET 200BL station}
 \end{aligned}$$

If you protect the modules listed above within an ET 200BL station with several ground-fault monitoring, you must determine the leakage resistance for each individual ground-fault monitoring.

Example

The structure of an ET 200BL station includes an IM 155-8 PN interface module and two I/O modules. The entire ET 200BL station is protected with **one** ground-fault monitoring:

$$R_{\text{ET 200BL}} = \frac{9.5 \text{ M}\Omega}{3} = 3.17 \text{ M}\Omega$$

Figure C-1 Calculation example for leakage resistance

Glossary

Automation system

Programmable logic controller for the open-loop and closed-loop control of process sequences of the process engineering industry and manufacturing technology. The automation system consists of different components and integrated system functions depending on the automation task.

AWG (American Wire Gauge)

A standard measure for conductors used in the USA, which is assigned to a specific cross-sectional area of a conductor or wire. Each AWG number represents a jump of 26% in the cross-sectional area. The thicker the wire, the smaller the AWG number.

Baud rate

Speed at which data is transferred, indicating the number of transmitted bits per second (baud rate = bit rate).

Bus

Joint transmission path to which all participants of a fieldbus system are connected; has two defined ends.

Configuration

Systematic arrangement of the individual modules.

Configuration control

Function that enables a flexible adjustment of the actual configuration based on a configured maximum configuration via the user program. Input, output and diagnostics addresses remain unchanged.

Connecting to common potential

Configuring a new potential group for which a new infeed is set up for the supply voltage.

Connection plug

Physical connection between device and cable.

Crimping

Procedure in which two components, e.g. end sleeve and cable, are connected with each other by plastic strain.

Derating

Derating allows devices to be used even in harsh operating conditions by selectively restricting the output capacity. In the case of motor starters, this usually refers to operation at high ambient temperatures.

Device name

Before an IO device can be addressed by an IO controller, it must have a device name. An IO device is delivered without a device name. An IO device can only be addressed by the IO controller after it has been assigned a device name via the PG/PC or via the topology, e.g. for the transfer of configuration data (such as IP address) during startup or for the exchange of user data during cyclic operation.

Diagnostics

Monitoring functions for the recognition, localization, classification, display and further evaluation of errors, faults and alarms. They run automatically during plant operation. This increases the availability of plants because commissioning times and downtimes are reduced.

Distributed I/O system

System with input and output modules that are configured on a distributed basis, far away from the CPU controlling them.

DP

[→ Distributed I/O system](#)

Earth

Conductive earth whose electrical potential can be set equal to zero at any point.

Equipotential bonding

Electrical connection (potential equalization conductor) that brings the bodies of electrical equipment and other conductive bodies to the same or almost the same potential, in order to prevent disruptive or dangerous voltages between these bodies.

Firmware update

Upgrade of firmware for modules (interface modules, I/O modules etc.), e.g. after function extensions, to the newest firmware version (update).

Functional ground

Functional ground is a low-impedance current path between electric circuits and ground. It is not designed as a safety measure but instead, for example, as a measure to improve interference immunity.

Ground

All interconnected, inactive parts of a piece of equipment that cannot accept any dangerous contact voltage, even in the event of a fault.

Grounding

Grounding means connecting an electrically conductive part to a grounding electrode by means of a grounding system.

GSD file

As a Generic Station Description, this file contains all properties of a PROFINET device that are necessary for its configuration in XML format.

I/O modules

All modules, with the exception of the motor starters, that can be operated with a CPU or an interface module.

Identification data

Information that is saved in modules and that supports the user in checking the plant configuration and locating hardware changes.

Interface module

Module in the distributed I/O system. The interface module connects the distributed I/O system via a fieldbus to the CPU (IO controller) and prepares the data for and from I/O modules.

Line

All the modules attached to a mounting rail.

Load current supply

Supply of modules like the interface module, power supply modules, I/O modules, and (if applicable) sensors and actuators.

MAC address

Device identification unique worldwide, which is already assigned to each PROFINET device in the factory. Its 6 bytes are divided into 3 bytes for the manufacturer ID and 3 bytes for the device ID (serial number). The MAC address is usually legible on the device.

Main switch

Every industrial machine that falls under the scope of DIN EN 60204 Part 1 (VDE 0113, Part 1) must be equipped with a main switch that disconnects all electrical equipment from the network while cleaning, maintenance, and repair work is being carried out, as well as during long periods of downtime. Usually a switch which can be operated by hand that is stipulated

for electrical or mechanical prevention of a hazard. The main switch can also function as an EMERGENCY STOP device.

The main switch must meet the following requirements:

- Externally accessible mechanical rotary lock.
- Only one OFF position and one ON position with allocated stops.
- Two positions labeled "0" and "I". 4th lockable OFF position.
- Cover for the power supply terminals to protect against accidental contact.
- The switching capacity must correspond to AC-23 for motor switches and AC-22 for load-break switches (utilization category).
- Switch position displayed automatically.

Node

Device that can send, receive or amplify data via the bus, e.g. IO device via PROFINET IO.

OT

OT (Operational Technology): The use of hardware and software to monitor and control industrial plants.

Overload release

Overcurrent release that provides protection against overload.

Parameter assignment

Parameter assignment is the transfer of parameters from the IO controller/DP master to the IO device/DP slave.

Potential group

Group of I/O modules that are supplied jointly with the field power bus.

Prewiring

Wiring the electrics on a mounting rail before the I/O modules are connected.

Process image (I/O)

The CPU transfers the values from the input and output modules to this memory area. At the start of the cyclic program, the signal states of the input modules are transmitted to the process image input. At the end of the cyclic program, the process image output is transmitted as signal state to the output modules.

Product version (ES) = Functional status (FS)

The product version or functional status provides information on the hardware version of the module.

PROFINET

PROcess Field NETwork, open Industrial Ethernet standard which continues PROFIBUS and Industrial Ethernet. A cross-manufacturer communication, automation and engineering model by PROFIBUS International e.V., defined as an automation standard.

PROFINET IO

Communication concept for the realization of modular, distributed applications within the scope of PROFINET.

PROFINET IO device

Distributed field device that can be assigned to one or more IO controllers (e.g. distributed I/O system, valve terminals, frequency converters, switches).

Provider-Consumer principle

Principle of data communication on the PROFINET IO: in contrast to PROFIBUS, both parties are independent providers when sending data.

Push-in terminal

Push-in connections are a form of spring-loaded terminals allowing wiring without tools for rigid conductors or conductors equipped with end sleeves.

Reference identification

In accordance with EN 81346, a specific object is clearly referenced in relation to the system to whose components the object belongs. Thus, unique identification of the modules in the entire system is possible.

Reference potential

Potential from which the voltages of the participating circuits are considered and/or measured.

RoHS

EC Directive 2011/65/EU concerning the restriction of certain dangerous substances in electrical and electronic devices regulates the use of hazardous substances in devices and components. The English abbreviation RoHS is used to refer to this directive: (Restriction of the use of certain hazardous substances), as well as all related measures for implementing it into national legislation.

Self-establishing field power bus

Two internal, self-assembling buses (L+, M) that supply the I/O modules with voltage.

SELV

Safety Extra Low Voltage

Service life

Period of time for which the switching device will work properly under normal operating conditions. This is specified as the number of operating cycles, the electrical durability (e.g. contact erosion), and the mechanical durability (e.g. operating cycles without load).

SNMP

SNMP (Simple Network Management Protocol) is the standardized protocol for diagnosing and also configuring the Ethernet infrastructure.

In the office area and in automation technology, devices support a wide range of manufacturers on the Ethernet SNMP.

SNMP-based applications can be operated on the same network in parallel to applications with PROFINET.

Switch

Industrial Ethernet consists of point-to-point connections: each communication node is interconnected directly with precisely one other communication node.

If a communication node is linked to several communication nodes, this communication node is connected to the port of an active network component - the switch. Other communication devices (including switches) can then be connected to the other ports of the switch. The connection between a communication node and the switch remains a point-to-point connection.

The task of a switch is thus to regenerate and distribute received signals. The switch "learns" the Ethernet address(es) of a connected PROFINET device or additional switches and only forwards those signals that are intended for the connected PROFINET device or switch.

A switch has a specific number of connections (ports). You connect at most one PROFINET device or additional switch to each port.

TIA Portal

Totally Integrated Automation Portal

The TIA Portal is the key to the full performance capability of Totally Integrated Automation. The software optimizes all operating, machine and process sequences.

TWIN end sleeve

End sleeve for two cables

Index

- 2**
 - 24 V DC supply, [55](#)
- A**
 - Accessible devices
 - Firmware update, [86](#)
 - Accessories, [103](#)
 - Approvals, [91](#)
- C**
 - Climatic environmental conditions, [98](#)
 - Color identification label, [40](#)
 - Description, [40](#)
 - Installing, [70](#)
 - Commissioning, [75](#)
 - Reset to factory settings, [88](#)
 - Components
 - ET 200BL at a glance, [39](#)
 - In accordance with DIN VDE regulation, [57](#)
 - Configuration, [38](#)
 - On grounded reference potential, [56](#)
 - Electrical, [59](#)
 - Configuration example, [76](#)
 - Configuration software, [73](#)
 - Configuring, [73](#)
- D**
 - Degree of protection, [100](#)
 - Dimensional diagram
 - Labeling strip, [101](#)
 - Reference identification label, [102](#)
 - Disassembly
 - End cover, [52](#)
- E**
 - Electrical isolation, [59](#)
 - Electrical relationships, [59](#)
 - Electromagnetic compatibility (EMC), [95](#)
 - EMC (Electromagnetic compatibility), [95](#)
 - EMERGENCY STOP devices, [54](#)
 - End cover, [40](#)
 - Mounting, dismantling, [52](#)
 - Environmental conditions
 - Mechanical, [97](#)
 - Climatic, [98](#)
 - ET 200BL
 - Area of application, [38](#)
 - Configuration example, [38](#)
 - Components, [39](#)
 - Rules and regulations for operation, [54](#)
 - Short-circuit / overload protection, [57](#)
 - Overall configuration, [58](#)
 - Configuring, [73](#)
 - Commissioning, [75](#)
 - Example
 - ET 200BL configuration, [38](#)
 - Leakage resistance, [105](#)
 - Exchanging
 - Terminal block, [82](#)
 - Exchanging the terminal block, [82](#)
 - External fuses/switches, [54](#)
- F**
 - Field power bus, [41](#)
 - Firmware update, [84](#)
- G**
 - Grounding
 - Configuration on grounded reference potential, [56](#)
 - Graphical overview of ET 200BL, [58](#)

I

- I/O module, [39](#)
 - Mounting, dismantling, [50](#)
 - Wiring rules, [60](#)
 - wiring, [62](#)
 - Inserting or removing, [81](#)
 - Exchanging the terminal block, [82](#)

Identification data, [77](#)

Incoming supply, grounded, [56](#)

Installation

- Mounting position, [43](#)
- Mounting rail, [44](#)
- Minimum clearances, [45](#)
- Rules, [46](#)
- Interface module, [47](#)
- I/O module, [50](#)
- End cover, [52](#)

Insulation, [99](#)

Interface module, [39](#)

- Mounting, dismantling, [47](#)
- Wiring rules, [60](#)
- Connecting the supply voltage, [64](#)
- Reset to factory settings, [88](#)

L

Labeling strip

- Dimensional diagram, [101](#)

Labeling strips, [40](#)

- Installing, [71](#)

Leakage resistance, [105](#)

Lightning protection, [55](#)

Line voltage, [55](#)

M

Maintenance

- Removal and insertion, [81](#)
- Exchanging the terminal block, [82](#)
- Firmware update, [84](#)

Marking, [66](#)

- Color coding, factory setting, [66](#)
- Optional, [68](#)

Maximum configuration, [41](#)

Mechanical environmental conditions, [97](#)

MFCT, [75](#)

Minimum clearances, [45](#)

Mounting, [46](#)

Mounting position, [43](#)

Mounting rail, [39](#), [44](#)

Mounting rail release, [50](#)

MultiFieldbus, [75](#)

O

Overall configuration, [58](#)

Overview, graphic

- ET 200BL grounding, [58](#)

P

Pollution degree, [100](#)

Potential group

- Operating principle, graphical overview, [42](#)

PROFINET IO, [75](#)

Protection class, [99](#), [100](#)

R

Radio interference, [96](#)

Rated voltage, [100](#)

Reference identification label, [40](#)

- Installing, [72](#)
- Dimensional diagram, [102](#)

Removal and insertion of modules, [81](#)

Reset to factory settings, [88](#)

S

Safe electrical separation, [56](#)

SELV

- Safe electrical separation, [56](#)

Shipping conditions, [97](#)

Short-circuit and overload protection according to DIN VDE regulation , [57](#)

SIMATIC ET 200BL, [37](#)

Spare parts, [103](#)

Standards, [91](#)

IEC 61131-2, [92](#)

IEC 61010-2-201, [92](#)

IEC 60695-11-10, [93](#)

UL 94, [93](#)

PROFINET, [93](#)

Use in industrial environments, [93](#)

Use in mixed areas, [93](#)

Use in residential areas, [93](#)

Environmental Product Declaration, [94](#)

Storage conditions, [97](#)

Supply voltage, [64](#)

Connecting, [64](#)

System rail, [39](#)

T

Technical specifications

Standards and approvals, [91](#)

Electromagnetic compatibility (EMC), [95](#)

Shipping and storage conditions, [97](#)

Mechanical environmental conditions, [97](#)

Climatic environmental conditions, [98](#)

Test voltage, [99](#)

W

Wiring

General rules for ET 200BL, [54](#)

Rules, [60](#)

I/O module, [62](#)