



We Tame Photons to Work for You!



For:

Products > LEDs > Thru-Hole > Round > 3mm > Mechanical Features > Short Lens



Features / Options

- ▶ State-of-the-Art, High Brightness Chip Technology
- ▶ Choice of Colors and Lens Finishes
- ▶ Lead Frame / Lens Casting Reliability
- ▶ Easy-to-Solder Leads, Tin Finish
- ▶ Available Bulk or on Tape and Reel
- ▶ Lead Trimming and Forming Available
- ▶ Custom Shapes, Easily Tooled, Low Minimum

Applications / Uses

- ▶ Board or Panel Indication or Illumination
- ▶ Annunciator and Control Panels
- ▶ Telecom Switches and Central Station Equipment
- ▶ Large Panel Indicators

Part Number:	Brightness	Dice Material	Emitted Color	Peak Wavelength	Epoxy Lens	Operating Typ Vf (V)	Intensity Typ, mcd @ 20 mA	View Angle 2x Theta	Sample
SSL-LX3044AC	STANDARD	GaAsP	Amber	605	Clear	2.1	80	30	—
SSL-LX3044AD	STANDARD	GaAsP	Amber	605	Diffused	2.1	15	60	—
SSL-LX3044GC	STANDARD	GaP	Green	565	Clear	2.1	100	30	—
SSL-LX3044GD	STANDARD	GaP	Green	565	Diffused	2.1	40	60	—
SSL-LX3044HC	STANDARD	GaP	Red	700	Clear	2.0	25	30	—
SSL-LX3044HD	STANDARD	GaP	Red	700	Diffused	2.0	6	60	—
SSL-LX3044IC	STANDARD	GaAsP	Red	635	Clear	2.0	125	30	—
SSL-LX3044ID	STANDARD	GaAsP	Red	635	Diffused	2.0	30	60	—
SSL-LX3044OD	STANDARD	GaP	Orange	630	Diffused	2.0	30	60	—
SSL-LX3044PGC	STANDARD	GaP	Green	555	Clear	2.1	15	30	—

UNCONTROLLED DOCUMENT

PART NUMBER		REV.
SSL-LX3044IC		E
REV.	E.C.N. NUMBER AND REVISION COMMENTS	DATE
A	REMOVED FLAT EDGE FROM FLANGE.	4.28.92
B	UPDATED CURRENT SPECS.	10.26.92
C	UPDATED SPECS.	11.28.94
D	UPDATED INTENSITY.	2.21.95
E	E.C.N. #10BRDR. & REDRAWN IN 3D.	4.11.01

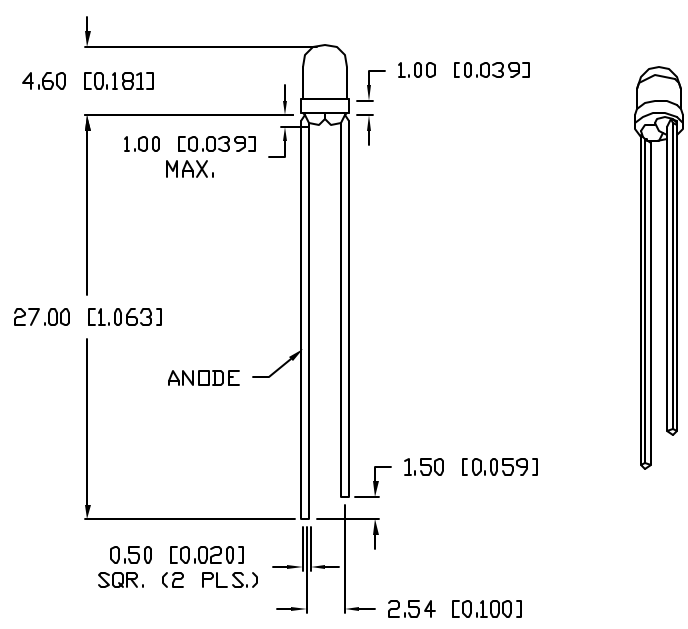
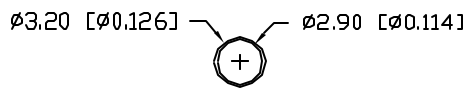

ELECTRO-OPTICAL CHARACTERISTICS $T_A=25^\circ\text{C}$ $I_f=20\text{mA}$

PARAMETER	MIN	TYP	MAX	UNITS	TEST COND
PEAK WAVELENGTH		635		nm	
FORWARD VOLTAGE		2.1	2.5	V_f	
REVERSE VOLTAGE	5.0			V_r	$I_f=100\mu\text{A}$
AXIAL INTENSITY		125		mcad	$I_f=20\text{mA}$
VIEWING ANGLE		30		2x theta	
EMITTED COLOR:	RED				
EPOXY LENS FINISH:	WATER CLEAR				

LIMITS OF SAFE OPERATION AT 25°C

PARAMETER	MAX	UNITS
PEAK FORWARD CURRENT*	150	mA
STEADY CURRENT	60	mA
POWER DISSIPATION	105	mW
DERATE FROM 25°C	-1.6	mW/°C
OPERATING, STORAGE TEMP.	-40 TO +85	°C
SOLDERING TEMP.	+260	°C
2.0mm FROM BODY		3 SEC. MAX

* $t < 10\mu\text{s}$

*UNLESS OTHERWISE SPECIFIED TOLERANCES PER DECIMAL PRECISION ARE: X=±1 (±0.039), XX=±0.5 (±0.020), XXX=±0.25 (±0.010), XXXX=±0.127 (±0.005). LEAD SIZE=±0.05 (±0.002), LEAD LENGTH=±0.75 (±0.030). MIN= ^{+0.00} _{-0.00} DECIMAL PRECISION MAX= ^{+0.00} _{-0.00} DECIMAL PRECISION

UNCONTROLLED DOCUMENT

REV.	PART NUMBER
E	SSL-LX3044IC
T-3mm (T-1) 635nm RED LED, WATER CLEAR LENS.	

CONFIDENTIAL INFORMATION
 THE INFORMATION CONTAINED IN THIS DOCUMENT IS THE PROPERTY OF LUMEX INC. EXCEPT AS SPECIFICALLY AUTHORIZED IN WRITING BY LUMEX INC., THE HOLDER OF THIS DOCUMENT SHALL KEEP ALL INFORMATION CONTAINED HEREIN CONFIDENTIAL AND SHALL PROTECT SAME IN WHOLE OR IN PART FROM DISCLOSURE AND DISSEMINATION TO ALL THIRD PARTIES.

RELIABILITY NOTE
 OUR MANY YEARS OF EXPERIENCE DATA ACCUMULATION INDICATE THAT SOLDER HEAT IS A MAJOR CAUSE OF EARLY AND FUTURE FAILURE. PLEASE PAY ATTENTION TO YOUR SOLDERING PROCESS.



DRAWN BY:	CHECKED BY:	APPROVED BY:	DATE: 5.30.90
BC			PAGE: 1 OF 1
			SCALE: N/A