

**TITLE :** W9333

**DIM.**  
**AS SHOWN**

**TOL.**  
0 +/- 1  
0.0 +/- 0.1  
0.00 +/- 0.01  
0.000 +/- 0.001

**DWN.** SD

**DATE.** 12/9/97

**SCALE.**  
NTS

**ISSUE.**  
01

**MODIFICATIONS.**  
NONE

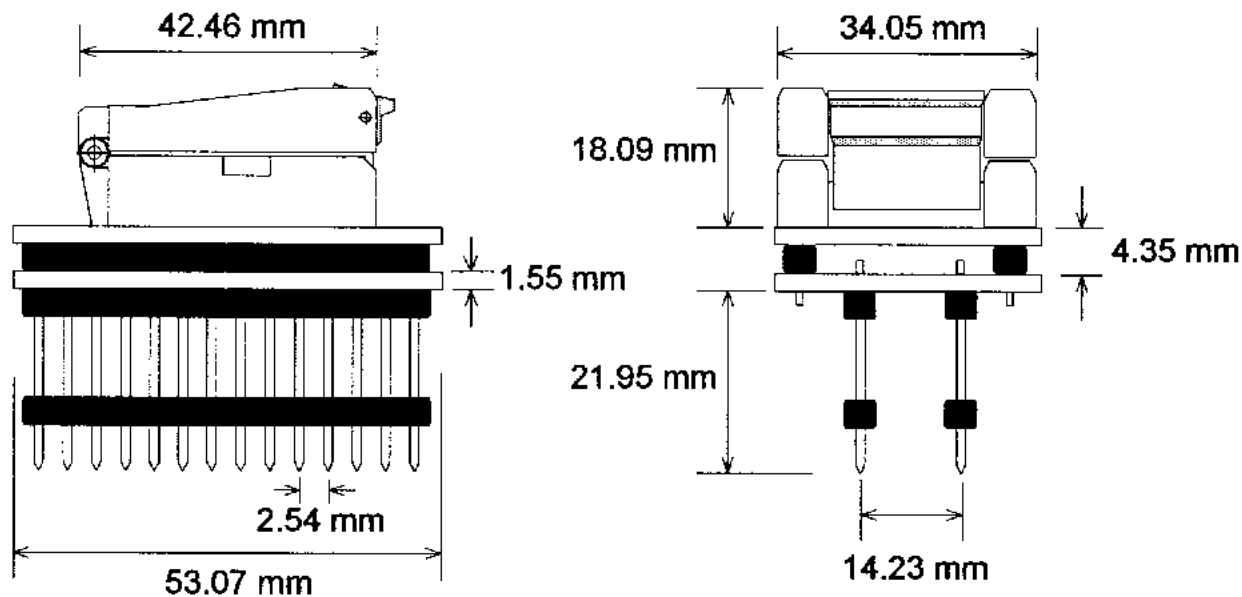

Note: pins shown for illustration only, quantity not representative of actual product.

# Winslow ADAPTICs Ltd

BRECON ENTERPRISE PARK.

BRECON. POWYS. LD3 8EF.

Tel : 0044 (0)1874 625555 Fax : 0044 (0)1874 625500

Email : SALES @ winslow.co.uk Web : <http://www.winslow.co.uk>

## DEVICES.

for details of suitable devices please contact factory.