

DATA SHEET

Part No.	AN48846B
Package Code No.	SMINI-5DE

Contents

■ Overview	3
■ Features	3
■ Applications	3
■ Package	3
■ Type	3
■ Block Diagram	4
■ Pin Descriptions	5
■ Absolute Maximum Ratings	6
■ Operating Supply Voltage Range	6
■ Allowable Voltage Range	6
■ Electrical Characteristics	7
■ Electrical Characteristics (Reference values for design)	8
■ Technical Data	9
• I/O block circuit diagram and pin function descriptions	9
• P_D — T_a diagram	10
■ Usage Notes	11
■ Caution on Use of Hall ICs	12

AN48846B

1.8 V Supply voltage, Low current consumption, high sensitivity CMOS Hall IC
Operates on Alternating Magnetic Field (low-speed rotation for lock direction)

■ Overview

AN48846B is a Hall IC (a magnetic sensor) for 1.8 V supply voltage by using Bi-CMOS technology.

In this Hall IC, a Hall element, a offset cancel circuit, an amplifier circuit, a sample and hold circuit, a Schmidt circuit, and output stage FET are integrated on a single chip housed in a small package by IC technique.

■ Features

- High sensitivity (4 mT max) due to offset cancel circuit and a new sample and hold circuit.
- Small current by using intermittent action. (average supply current : 55 μ A typ. sampling cycle : 660 μ s typ at $V_{CC} = 1.8$ V)
- Small package (SMD)
- CMOS inverter output (no pull-up resistance)

■ Applications

- Magneto-electric Conversion Switch.

■ Package

- 5 pin Plastic Small Surface Mount Package (SMINI Type).

■ Type

- Bi-CMOS IC.

■ Block Diagram

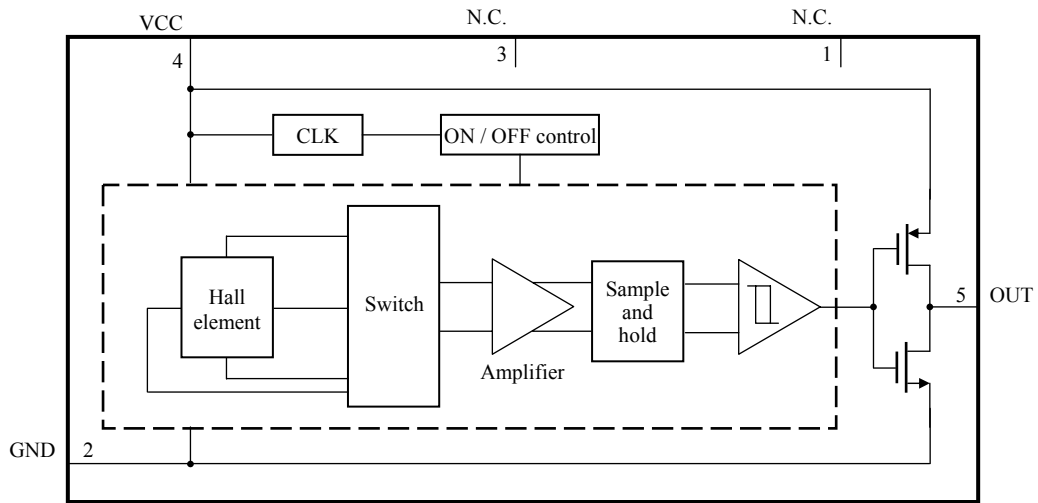

Note) This block diagram is for explaining functions. Part of the block diagram may be omitted, or it may be simplified.

■ Pin Descriptions

Pin No.	Pin name	Type	Description
1	N.C.	—	N.C.
2	GND	Ground	Ground pin
3	N.C.	—	N.C.
4	VCC	Power supply	Supply pin
5	OUT	Output	Output pin

■ Absolute Maximum Ratings

Note) Absolute maximum ratings are limit values which do not result in damages to this IC, and IC operation is not guaranteed at these limit values.

A No.	Parameter	Symbol	Rating	Unit	Notes
1	Supply voltage	V_{CC}	4.0	V	*1
2	Supply current	I_{CC}	5	mA	—
3	Power dissipation	P_D	48	mW	*2
4	Operating ambient temperature	T_{opr}	-40 to +85	°C	*3
5	Storage temperature	T_{stg}	-55 to +125	°C	*3

Notes) *1 : The values under the condition not exceeding the above absolute maximum ratings and the power dissipation.

*2 : The power dissipation shown is the value at $T_a = 85^\circ\text{C}$ for the independent (unmounted) IC package without a heat sink.

When using this IC, refer to the • $P_D - T_a$ diagram in the ■ Technical Data and design the heat radiation with sufficient margin so that the allowable value might not be exceeded based on the conditions of power supply voltage, load, and ambient temperature.

*3 : Except for the power dissipation, operating ambient temperature, and storage temperature, all ratings are for $T_a = 25^\circ\text{C}$.

■ Operating Supply Voltage Range

Parameter	Symbol	Range	Unit	Notes
Supply voltage range	V_{CC}	1.65 to 3.6	V	*1

Note) *1: The values under the condition not exceeding the above absolute maximum ratings and the power dissipation.

■ Allowable Voltage Range

Notes) • Allowable current and voltage ranges are limit ranges which do not result in damages to this IC, and IC operation is not guaranteed within these limit ranges.

• Voltage values, unless otherwise specified, are with respect to GND.

• Do not apply external currents or voltages to any pin not specifically mentioned.

Pin No.	Pin name	Range	Unit	Note
2	GND	0	V	—
5	OUT	-0.3 to ($V_{CC} + 0.3$)	V	*1

Note) *1 : ($V_{CC} + 0.3$) V \leq 4.0 V.

■ Electrical Characteristics at $V_{CC} = 1.8\text{ V}$

Note) $T_a = 25^\circ\text{C} \pm 2^\circ\text{C}$ unless otherwise specified.

B No.	Parameter	Symbol	Conditions	Limits			Unit	Notes
				Min	Typ	Max		
1	Operating magnetic flux density H → L	BHL	—	0.5	2.5	4.0	mT	*1
2	Operating magnetic flux density L → H	BLH	—	-4.0	-2.5	-0.5	mT	*1
3	Output voltage Low	V_{OL}	$I_O = 2\text{ mA}, B = 4.0\text{ mT}$	—	0.1	0.3	V	—
4	Output voltage High	V_{OH}	$I_O = -2\text{ mA}, B = -4.0\text{ mT}$	1.5	1.7	—	V	—
5	Average supply current	I_{CC} (AVE)	—	—	55	65	μA	*2
6	Sampling Period	T_{sam}	—	215	660	1030	μs	—

■ Electrical Characteristics (Reference values for design) at $V_{CC} = 1.8\text{ V}$

Note) $T_a = 25^\circ\text{C} \pm 2^\circ\text{C}$ unless otherwise specified.

The characteristics listed below are reference values derived from the design of the IC and are not guaranteed by inspection.

If a problem does occur related to these characteristics, we will respond in good faith to user concerns.

B No.	Parameter	Symbol	Conditions	Reference Values			Unit	Notes
				Min	Typ	Max		
7	Hysteresis width	BW	—	—	5.0	—	mT	—
8	Active supply current	$I_{CC(ON)}$	—	—	—	5.0	mA	*3
9	Standby supply current	$I_{CC(OFF)}$	—	—	—	4	μA	*3
10	Active time	$t(ON)$	—	—	—	21	μs	*3
11	Standby time	$t(OFF)$	—	—	—	640	μs	*3

Notes) *1: Symbol BHL shows the operating magnetic flux density at which output level is changed from high to low, and Symbol BLH shows the operating magnetic flux density at which output level is changed from low to high.

*2: $I_{CC(AVE)} = \{I_{CC(ON)} \times t(ON) + I_{CC(OFF)} \times t(OFF)\} / \{t(ON) + t(OFF)\}$.

*3: Power Supply Timing Chart

Normal operation starts approx. 660 μs after power supply is turned on.

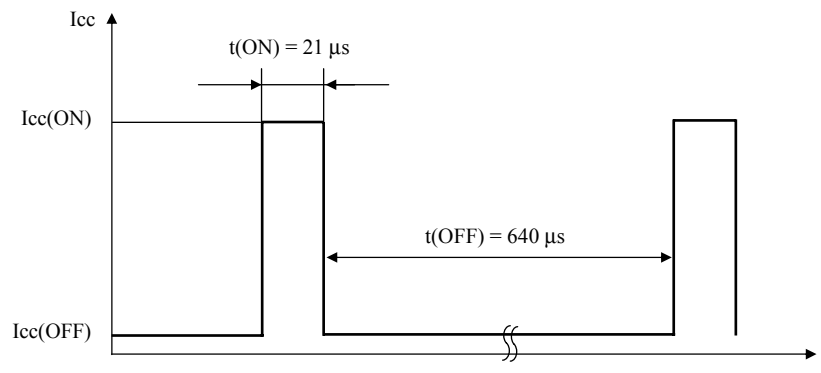

■ Technical Data

- I/O block circuit diagrams and pin function descriptions

Note) The characteristics listed below are reference values derived from the design of the IC and are not guaranteed.

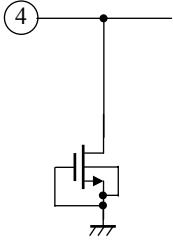
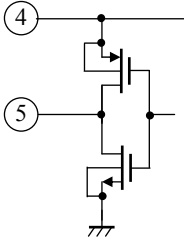
Pin No.	Waveform and voltage	Internal circuit	Impedance	Description
2	DC Voltage (0 V)	—	0 Ω	Ground pin [GND]
4	DC Voltage (0 V to 3.6 V)		Hi-Z	Supply pin [VCC]
5	Pulse Output (0 V to 3.6 V)		Hi-Z	Positive output pin [OUT]

■ Technical Data

- $P_D - T_a$ diagram

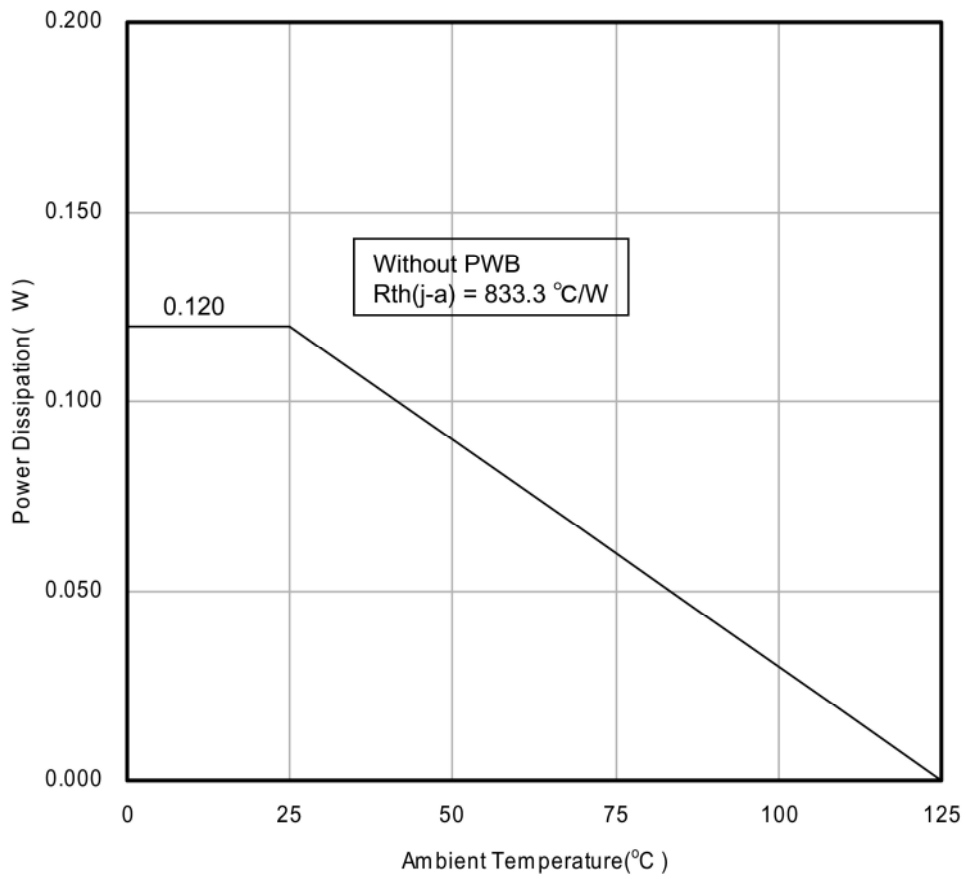

■ Usage Notes**• Special attention and precaution in using**

1. This IC is intended to be used for general electronic equipment.

Consult our sales staff in advance for information on the following applications:

- Special applications in which exceptional quality and reliability are required, or if the failure or malfunction of this IC may directly jeopardize life or harm the human body.
- Any applications other than the standard applications intended.
 - (1) Space appliance (such as artificial satellite, and rocket)
 - (2) Traffic control equipment (such as for automobile, airplane, train, and ship)
 - (3) Medical equipment for life support
 - (4) Submarine transponder
 - (5) Control equipment for power plant
 - (6) Disaster prevention and security device
 - (7) Weapon
 - (8) Others : Applications of which reliability equivalent to (1) to (7) is required

It is to be understood that our company shall not be held responsible for any damage incurred as a result of or in connection with your using the IC described in this book for any special application, unless our company agrees to your using the IC in this book for any special application.

2. Pay attention to the direction of LSI. When mounting it in the wrong direction onto the PCB (printed-circuit-board), it might smoke or ignite.
3. Pay attention in the PCB (printed-circuit-board) pattern layout in order to prevent damage due to short circuit between pins. In addition, refer to the Pin Description for the pin configuration.
4. Perform a visual inspection on the PCB before applying power, otherwise damage might happen due to problems such as a solder-bridge between the pins of the semiconductor device. Also, perform a full technical verification on the assembly quality, because the same damage possibly can happen due to conductive substances, such as solder ball, that adhere to the LSI during transportation.
5. Take notice in the use of this product that it might break or occasionally smoke when an abnormal state occurs such as output pin- V_{CC} short (Power supply fault), output pin-GND short (Ground fault), or output-to-output-pin short (load short) .
And, safety measures such as an installation of fuses are recommended because the extent of the above-mentioned damage and smoke emission will depend on the current capability of the power supply.
6. When designing your equipment, comply with the range of absolute maximum rating and the guaranteed operating conditions (operating power supply voltage and operating environment etc.). Especially, please be careful not to exceed the range of absolute maximum rating on the transient state, such as power-on, power-off and mode-switching. Otherwise, we will not be liable for any defect which may arise later in your equipment.
Even when the products are used within the guaranteed values, take into the consideration of incidence of break down and failure mode, possible to occur to semiconductor products. Measures on the systems such as redundant design, arresting the spread of fire or preventing glitch are recommended in order to prevent physical injury, fire, social damages, for example, by using the products.
7. When using the LSI for new models, verify the safety including the long-term reliability for each product.
8. When the application system is designed by using this LSI, be sure to confirm notes in this book.
Be sure to read the notes to descriptions and the usage notes in the book.
9. This IC is not applicable to automotive electronic parts.

■ Caution on Use of Hall ICs

As the Hall-IC often detects movement, the position of the Hall-IC may be changed, and there is the risk of a change in detection level, if exposed to shock or vibration over a long period. Secure the IC by applying adhesive to the package or placing in a dedicated case.

1. When using an adhesive

Some kinds of adhesive generate gas (such as chlore gas) during curing. This corrosive gas corrodes the aluminum on the surface of the Hall-IC, and may cause a functional defect of disconnection.

If Hall-IC is to be sealed after installation, attention should be given to the adhesive used for Hall-IC installation, as well as for the adhesive or resin used for peripherals and substrate cleaner.

Please confirm the above matter to those manufacturers before using.

We could not select the specified adhesive, for we find it difficult to guarantee the ingredient of each adhesive.

2. Power supply line/ Power transmission line

If a power supply line/power transmission line becomes longer, noise and/or oscillation may be found on the line. In this case, set the capacitor of 0.1 mF to 10 mF near the Hall IC to prevent it.

If a voltage of 5.4 V or more is thought to be applied to the power supply line (reverse electromotive force from coil or the ignition pulse, etc.), protect it with external components (capacitor, resistor, zener diode, diode, surge absorbing elements, etc.).

3. Mounting the surface mount type (SMINI-5DE package)

When mounted on printed circuit board, the Hall-IC may be highly stressed by the warpage that may occur from the soldering. This may also cause a change in the operating magnetic flux density and a deterioration of its resistance to moisture.



Observe the recommended conditions since electrical characteristics can easily change due to stress when mounting. Avoid soldering by using soldering iron or solder flow (dip) method.

4. V_{CC} and GND

Do not connect V_{CC} and GND pins reversely. Otherwise, the IC will be damaged. If the voltage of GND pin is set higher than that of the other pins, which is the same configuration as diode forward connection, it is set to ON at current may flow (About 0.7V), resulting in damage to the IC. (This is common to monolithic IC.)

5. Cautions of Hall IC at Power-On

When a Hall IC is turned on, the position of the magnet or looseness may cause the output of a Hall IC to be changed, and a pulse may be generated.

Therefore, care should be exercised whenever the output state of a Hall IC is critical when the supply power is ON.

6. When Hall-IC is fixed with holder

When a Hall-IC is mounted on the printed circuit board with a holder and the coefficient of expansion of the holder is large, the lead wire of the Hall-IC will be stretched and it may give a stress to the Hall IC.

If the lead wire is stressed intensely due to the distortion of holder or substrate, the adhesiveness between the package and the lead wire may be weakened and cause a minute gap resulting in the deterioration of its resistance to moisture.

7. On using flux in soldering

Choose a flux which does not include ingredients from the chloric group. The ingredients of chloric group may enter through the joint of the lead frame and package resin, causing corrosion and disconnection of the aluminum wiring on the surface of IC chip.

Request for your special attention and precautions in using the technical information and semiconductors described in this book

- (1) If any of the products or technical information described in this book is to be exported or provided to non-residents, the laws and regulations of the exporting country, especially, those with regard to security export control, must be observed.
- (2) The technical information described in this book is intended only to show the main characteristics and application circuit examples of the products. No license is granted in and to any intellectual property right or other right owned by Panasonic Corporation or any other company. Therefore, no responsibility is assumed by our company as to the infringement upon any such right owned by any other company which may arise as a result of the use of technical information described in this book.
- (3) The products described in this book are intended to be used for general applications (such as office equipment, communications equipment, measuring instruments and household appliances), or for specific applications as expressly stated in this book.
Consult our sales staff in advance for information on the following applications:
 - Special applications (such as for airplanes, aerospace, automotive equipment, traffic signaling equipment, combustion equipment, life support systems and safety devices) in which exceptional quality and reliability are required, or if the failure or malfunction of the products may directly jeopardize life or harm the human body.It is to be understood that our company shall not be held responsible for any damage incurred as a result of or in connection with your using the products described in this book for any special application, unless our company agrees to your using the products in this book for any special application.
- (4) The products and product specifications described in this book are subject to change without notice for modification and/or improvement. At the final stage of your design, purchasing, or use of the products, therefore, ask for the most up-to-date Product Standards in advance to make sure that the latest specifications satisfy your requirements.
- (5) When designing your equipment, comply with the range of absolute maximum rating and the guaranteed operating conditions (operating power supply voltage and operating environment etc.). Especially, please be careful not to exceed the range of absolute maximum rating on the transient state, such as power-on, power-off and mode-switching. Otherwise, we will not be liable for any defect which may arise later in your equipment.
Even when the products are used within the guaranteed values, take into the consideration of incidence of break down and failure mode, possible to occur to semiconductor products. Measures on the systems such as redundant design, arresting the spread of fire or preventing glitch are recommended in order to prevent physical injury, fire, social damages, for example, by using the products.
- (6) Comply with the instructions for use in order to prevent breakdown and characteristics change due to external factors (ESD, EOS, thermal stress and mechanical stress) at the time of handling, mounting or at customer's process. When using products for which damp-proof packing is required, satisfy the conditions, such as shelf life and the elapsed time since first opening the packages.
- (7) This book may be not reprinted or reproduced whether wholly or partially, without the prior written permission of our company.