

Feb.1.2018 Copyright 2018 HIROSE ELECTRIC CO., LTD. All Rights Reserved.

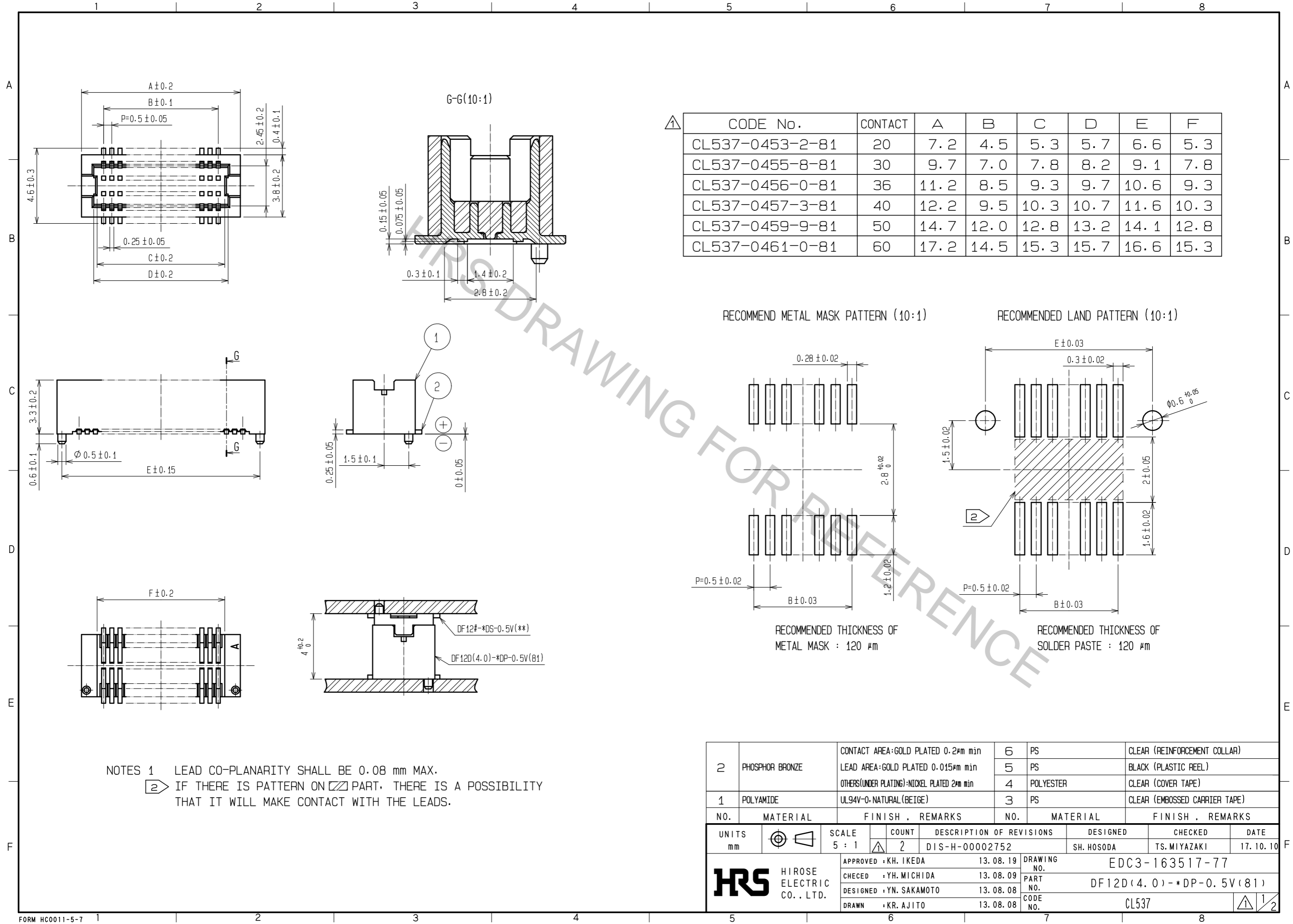

CODE No.	CONTACT	A	B	C	D	E	F
CL537-0453-2-81	20	7.2	4.5	5.3	5.7	6.6	5.3
CL537-0455-8-81	30	9.7	7.0	7.8	8.2	9.1	7.8
CL537-0456-0-81	36	11.2	8.5	9.3	9.7	10.6	9.3
CL537-0457-3-81	40	12.2	9.5	10.3	10.7	11.6	10.3
CL537-0459-9-81	50	14.7	12.0	12.8	13.2	14.1	12.8
CL537-0461-0-81	60	17.2	14.5	15.3	15.7	16.6	15.3

RECOMMEND METAL MASK PATTERN (10:1)

RECOMMENDED LAND PATTERN (10:1)

RECOMMENDED THICKNESS OF METAL MASK : 120 μm

RECOMMENDED THICKNESS OF SOLDER PASTE : 120 μm

NOTES 1 LEAD CO-PLANARITY SHALL BE 0.08 mm MAX.
 2 IF THERE IS PATTERN ON PART, THERE IS A POSSIBILITY THAT IT WILL MAKE CONTACT WITH THE LEADS.

2	PHOSPHOR BRONZE	CONTACT AREA:GOLD PLATED 0.2μm min	6	PS	CLEAR (REINFORCEMENT COLLAR)
		LEAD AREA:GOLD PLATED 0.015μm min	5	PS	BLACK (PLASTIC REEL)
		OTHERS(UNDER PLATING):NICKEL PLATED 2μm min	4	POLYESTER	CLEAR (COVER TAPE)
1	POLYAMIDE	UL94V-0.NATURAL(BEIGE)	3	PS	CLEAR (EMBOSSED CARRIER TAPE)
NO.	MATERIAL	FINISH . REMARKS	NO.	MATERIAL	FINISH . REMARKS
UNITS mm		SCALE 5 : 1	COUNT 2	DESCRIPTION OF REVISIONS DIS-H-00002752	
DESIGNED SH. HOSODA		CHECKED TS. MIYAZAKI		DATE 17. 10. 10	
APPROVED : KH. IKEDA		13. 08. 19		DRAWING NO. EDC3-163517-77	
CHECKED : YH. MICHIDA		13. 08. 09		PART NO. DF12D(4.0)*DP-0.5V(81)	
DESIGNED : YN. SAKAMOTO		13. 08. 08		CODE NO. CL537	
DRAWN : KR. AJITO		13. 08. 08			

Feb.1.2018 Copyright 2018 HIROSE ELECTRIC CO., LTD. All Rights Reserved.

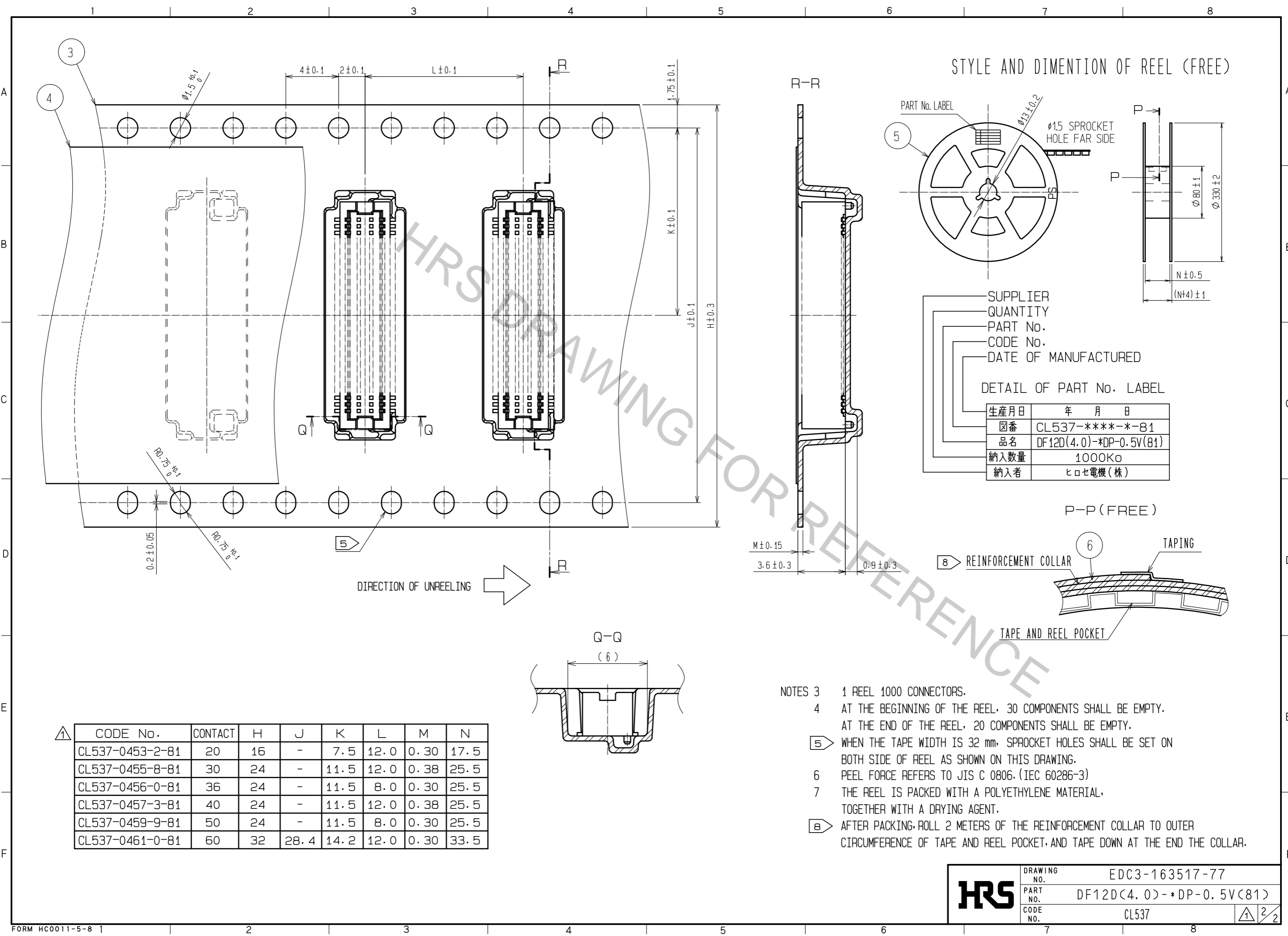

STYLE AND DIMENTION OF REEL (FREE)

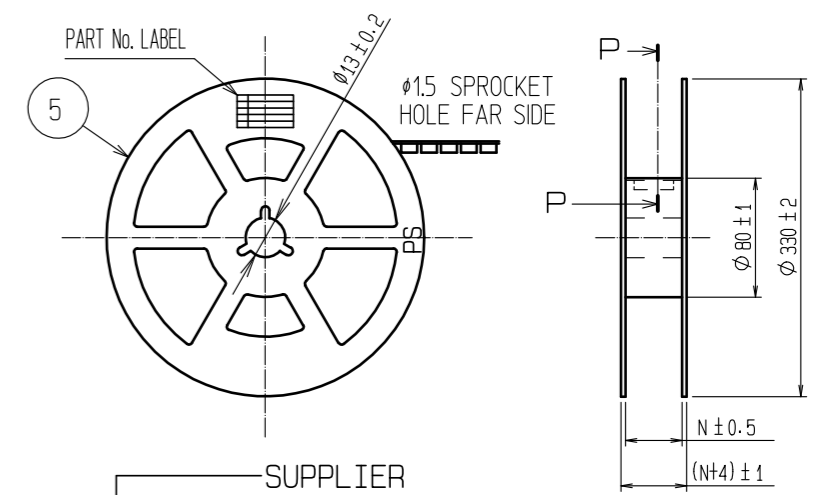

SUPPLIER
QUANTITY
PART No.
CODE No.
DATE OF MANUFACTURED

DETAIL OF PART No. LABEL

生産月日	年 月 日
図番	CL537-****-*81
品名	DF12D(4.0)*DP-0.5V(81)
納入数量	1000K0
納入者	ヒロセ電機(株)

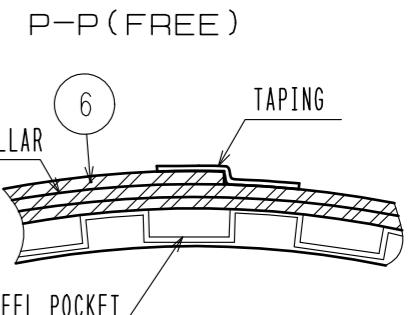

DIRECTION OF UNREELING →

CODE No.	CONTACT	H	J	K	L	M	N
CL537-0453-2-81	20	16	-	7.5	12.0	0.30	17.5
CL537-0455-8-81	30	24	-	11.5	12.0	0.38	25.5
CL537-0456-0-81	36	24	-	11.5	8.0	0.30	25.5
CL537-0457-3-81	40	24	-	11.5	12.0	0.38	25.5
CL537-0459-9-81	50	24	-	11.5	8.0	0.30	25.5
CL537-0461-0-81	60	32	28.4	14.2	12.0	0.30	33.5

- NOTES 3 1 REEL 1000 CONNECTORS.
 4 AT THE BEGINNING OF THE REEL, 30 COMPONENTS SHALL BE EMPTY. AT THE END OF THE REEL, 20 COMPONENTS SHALL BE EMPTY.
 5 WHEN THE TAPE WIDTH IS 32 mm, SPROCKET HOLES SHALL BE SET ON BOTH SIDE OF REEL AS SHOWN ON THIS DRAWING.
 6 PEEL FORCE REFERS TO JIS C 0806. (IEC 60286-3)
 7 THE REEL IS PACKED WITH A POLYETHYLENE MATERIAL, TOGETHER WITH A DRYING AGENT.
 8 AFTER PACKING, ROLL 2 METERS OF THE REINFORCEMENT COLLAR TO OUTER CIRCUMFERENCE OF TAPE AND REEL POCKET, AND TAPE DOWN AT THE END THE COLLAR.

HRS	DRAWING NO.	EDC3-163517-77
	PART NO.	DF12D(4.0)*DP-0.5V(81)
	CODE NO.	CL537