



PCB ANTENNA, TAB MOUNT MIMO, 1557-7125MHz (51.0 x 14.2 x 1.61mm)

Part Numbers: **L000646-01**
L000646-80

FEATURES & BENEFITS

- Smaller antenna clearance area compared to PCB / Chip antennas
- Omnidirectional coverage
- Wide Band coverage for 3G, 4G, 5G MIMO and GNSS
- Evaluation board available for testing (L000646-80)
- Bandwidth and performance dependent on ground plane size / design (suggested minimum ground plane length from antenna feed is 100mm)
- RoHS 2.0 Compliant, Road Vehicle Compliant, REACH Compliant

SPECIFICATIONS

Frequency Range (MHz)	1557-1610	1710-2690	3300-5000	5150-7125
VSWR	< 3.5:1	< 2.5:1	< 4:1	< 3:1
Average Efficiency	52.00%	57.00%	53.00%	48%
Peak Gain	0.7dBi	2.9dBi	1.8dBi	1.4dBi
Average Gain	-2.8dBi	-2.5dBi	-2.8dBi	-3.5dBi
Power Handling	5 Watt cw			
Feed Point Impedance	50 ohms unbalanced			
Polarization	Linear			
Size	51.0 mm x 14.2 mm x 1.61 mm			
Weight	< 1.5 g			
Mounting	Surface mount			
Operating Temperature	-40 to +85°C			
Storage Temperature	-40 to +85°C			
Packaging Specification	Bag & Box			
Hazardous Materials	A certificate of conformance is available from the product page on TE website.			

Data measured in free space and on reference ground plane of 100 mm ground length and 100 mm width, application data might vary.

RF DATA

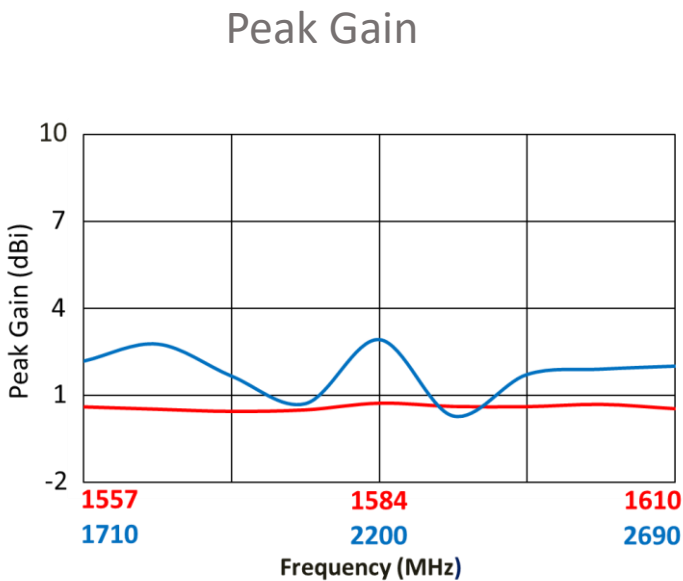
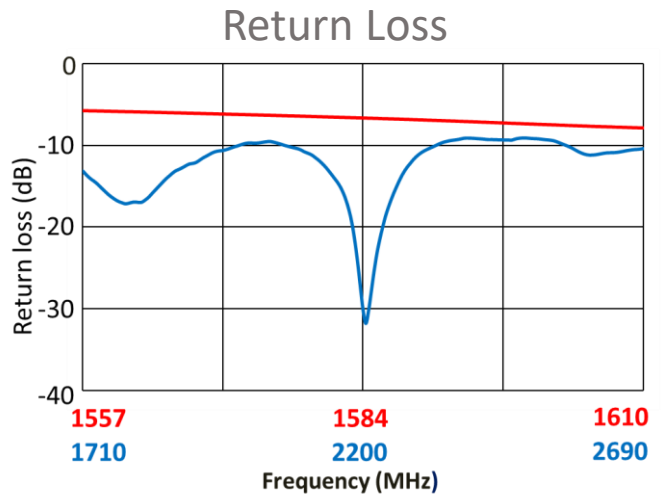
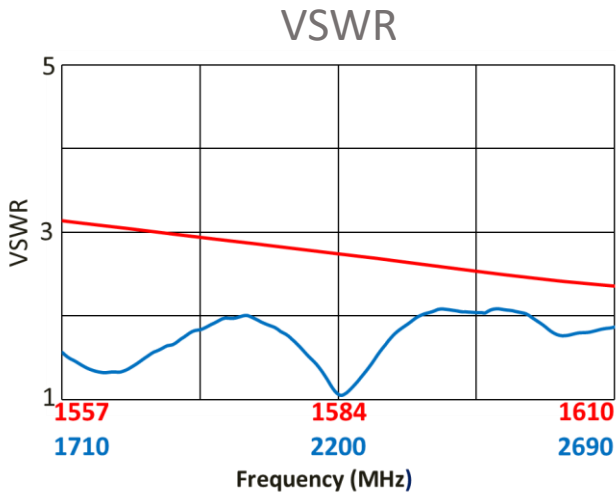

Data measured in free space and on reference ground plane of 100mm ground length and 100mm width, application data might vary.

RF DATA

VSWR

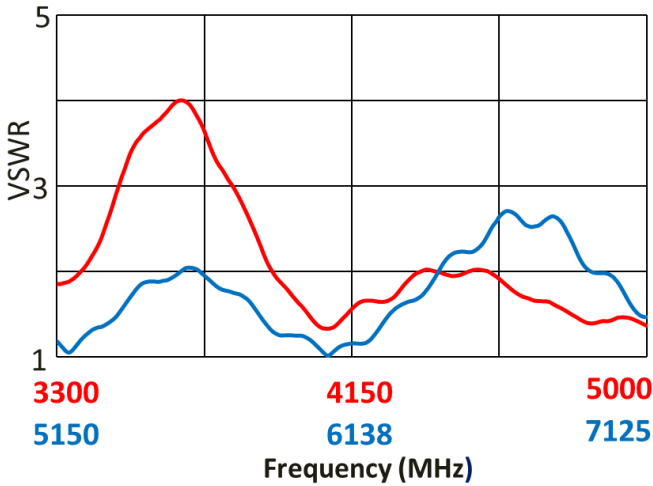

Return Loss

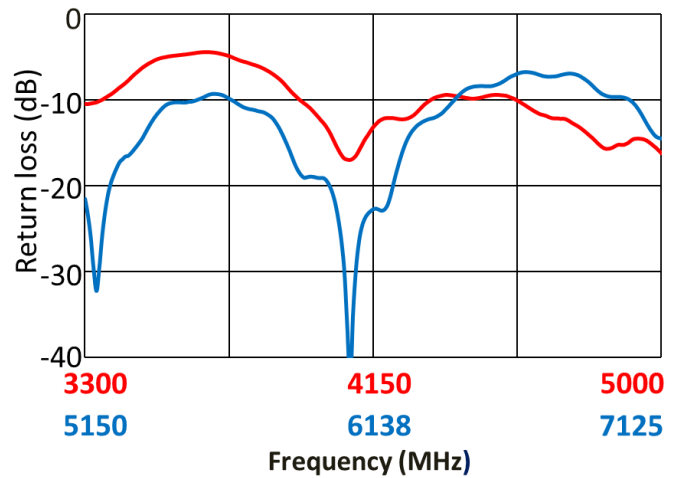

Peak Gain

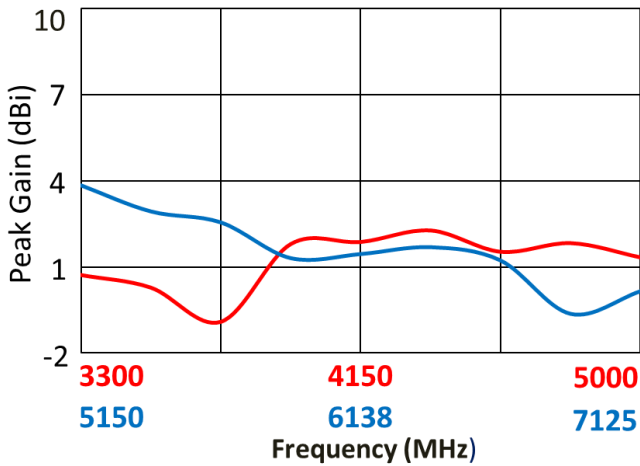

Efficiency

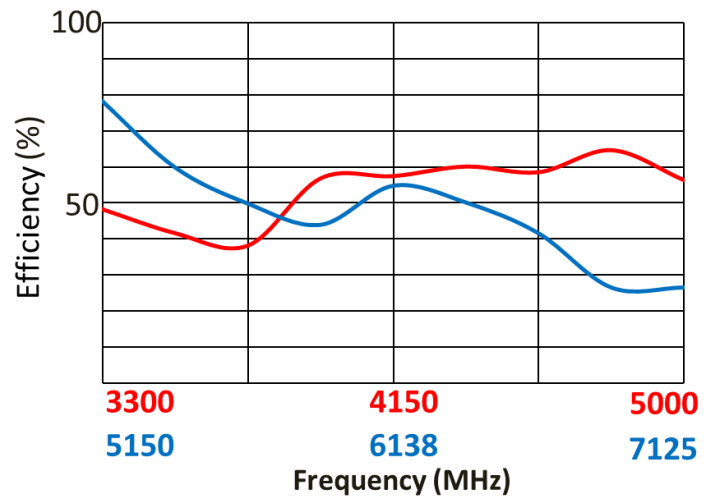

Data measured in free space and on reference ground plane of 100mm ground length and 100mm width, application data might vary.

RADIATION PATTERN

Test setup

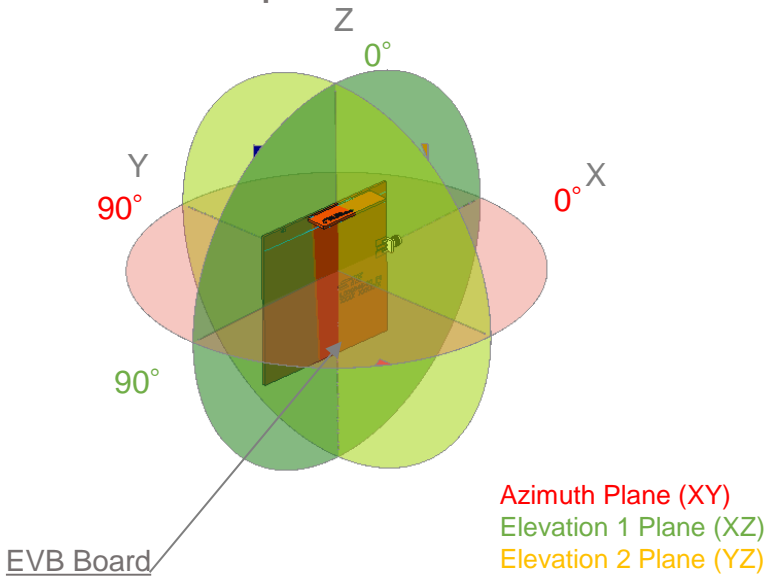

Azimuth(XY)

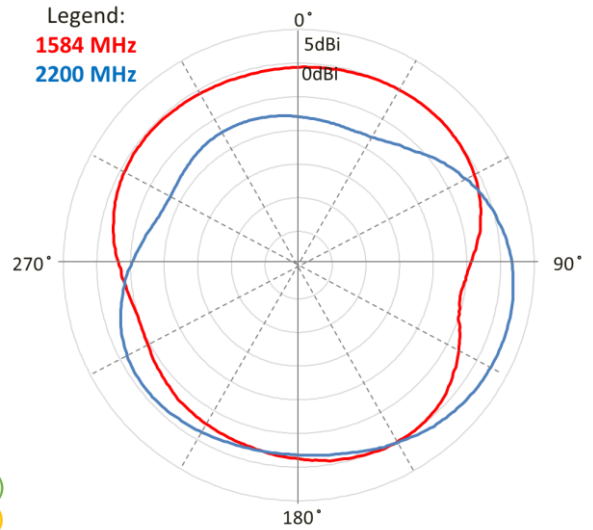

Elevation 1(XZ)

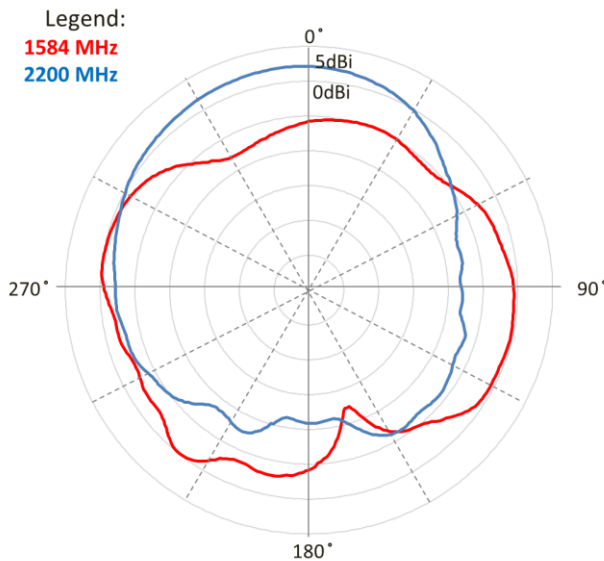

Elevation 2(YZ)

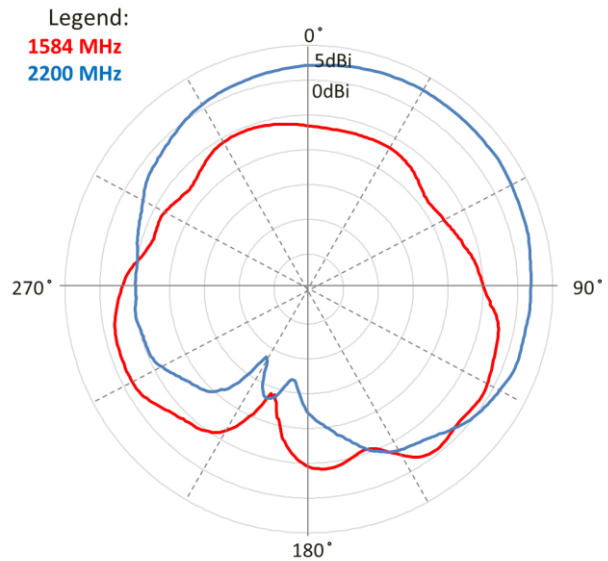

Data measured in free space and on reference ground plane of 100mm ground length and 100mm width, application data might vary.

RADIATION PATTERN

Test setup

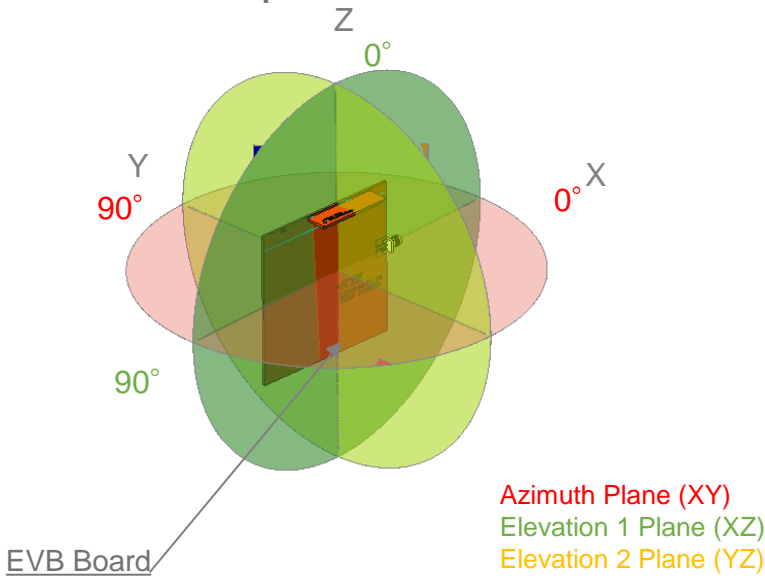

Azimuth(XY)

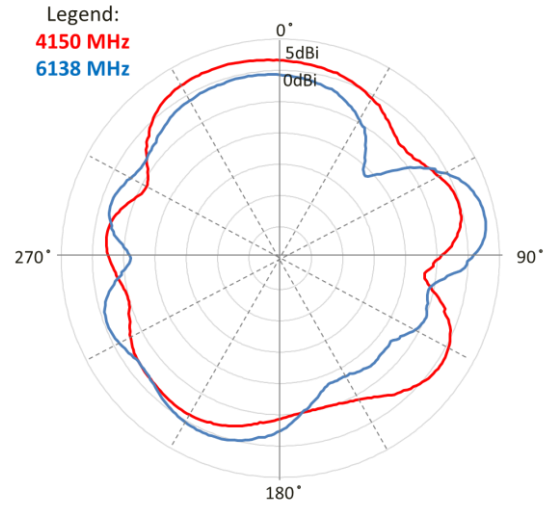

Elevation 1(XZ)

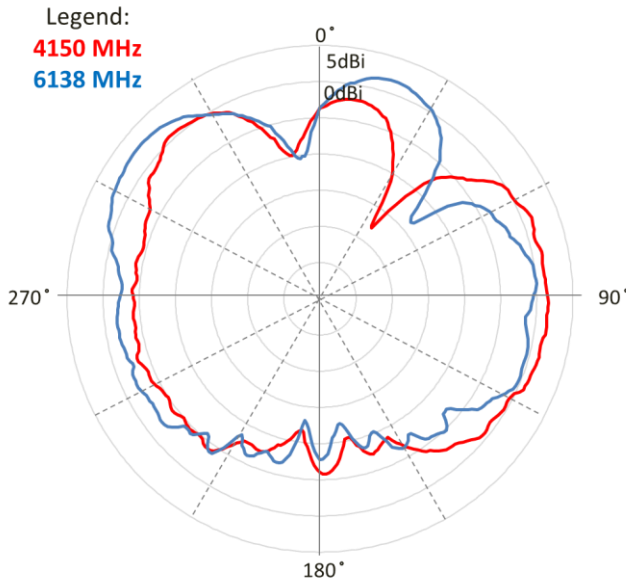

Elevation 2(YZ)

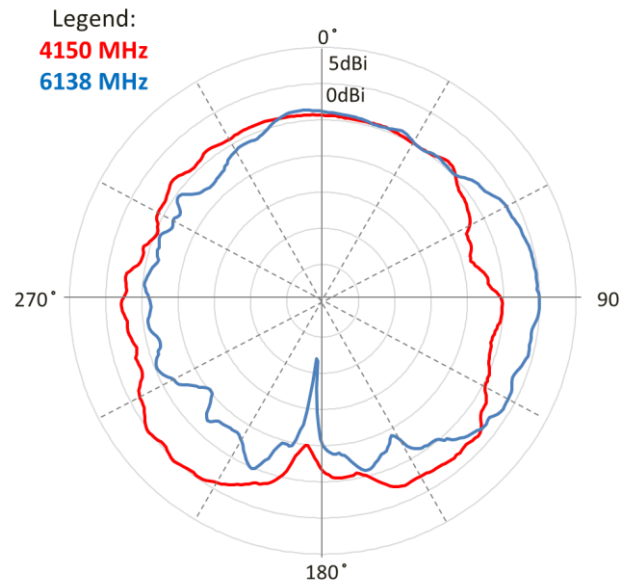

Data measured in free space and on reference ground plane of 100mm ground length and 100mm width, application data might vary.

MOUNTING GUIDE

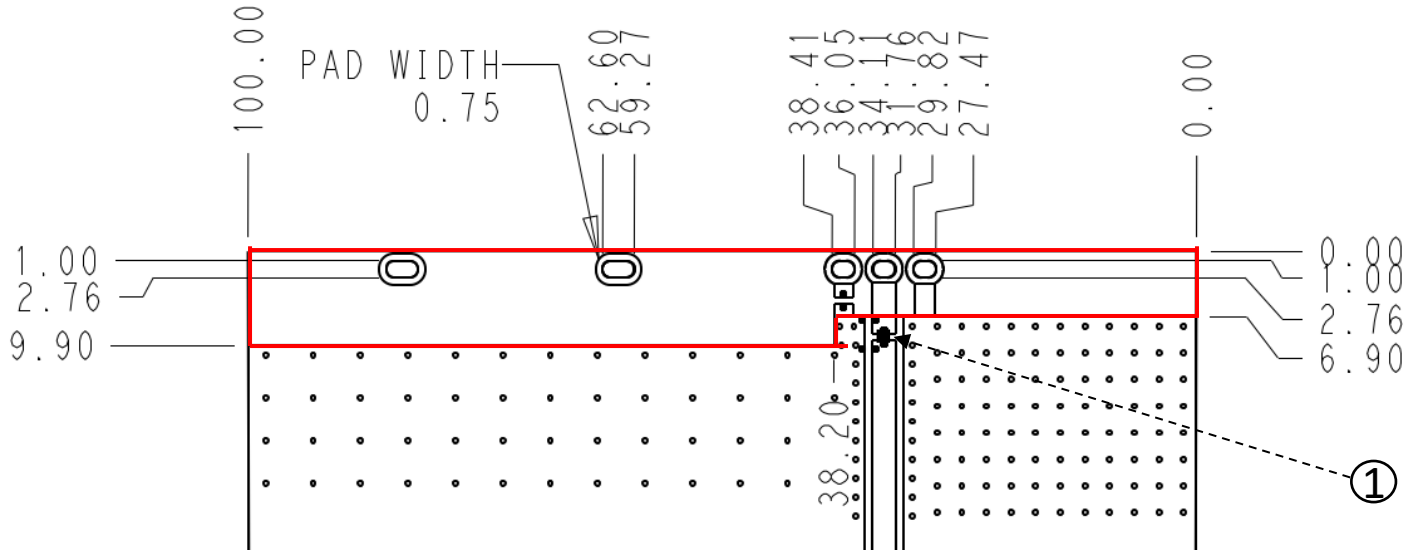

- NOTES:**
- 1. Antenna must be mounted on the edge of PCB.
 - 2. NC = Non connection (mechanical mounting pads).
 - 3. No copper allowed in designated area on all PCB layers –
 - 4. For more information please call TE.
 - 5. Measured with below matching circuit condition.
 - ① 0 ohm
 - 6. Reference PCB Dimension(mm) - 100 x 100 x 1.6 (dielectric 4.3)

Dimensions: mm
Diagram is not to scale

PCB ANTENNA, TAB MOUNT MIMO, 1557-7125MHz (51.0 x 14.2 x 1.61mm)

Standard Antenna Solutions

KEEP OUT AREA

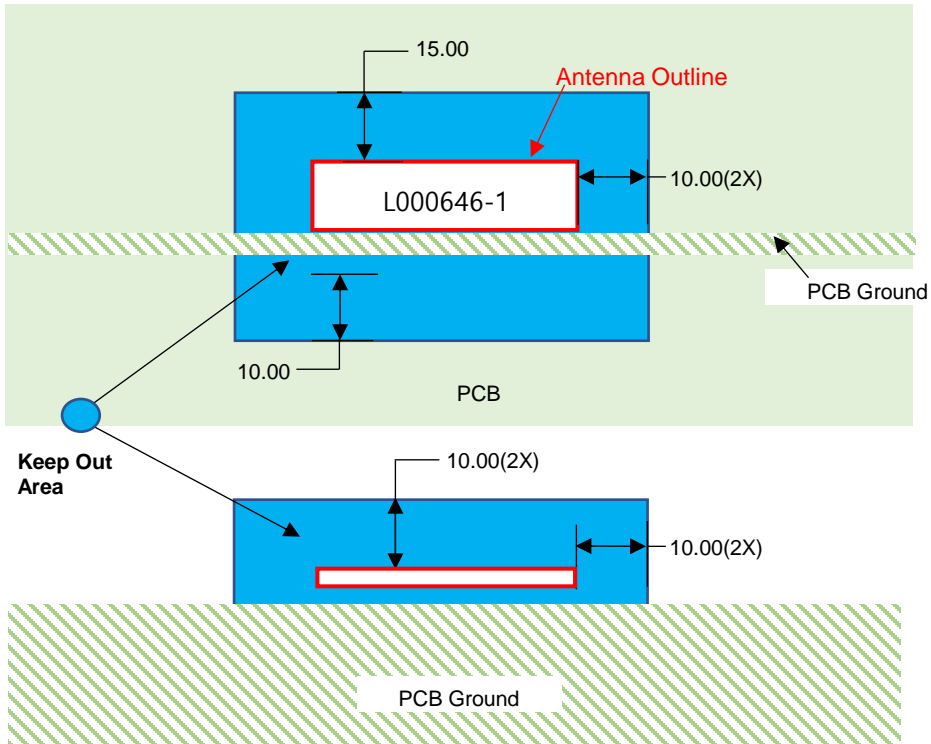

- NOTES: 1. Antenna designed to be mounted on PCB.
 2. Area in blue above indicates Keep Out Area.
 3. For more information please call TE.

Dimensions: mm
 Diagram is not to scale

DIMENSIONS

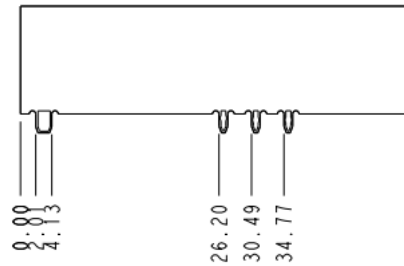
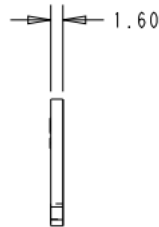
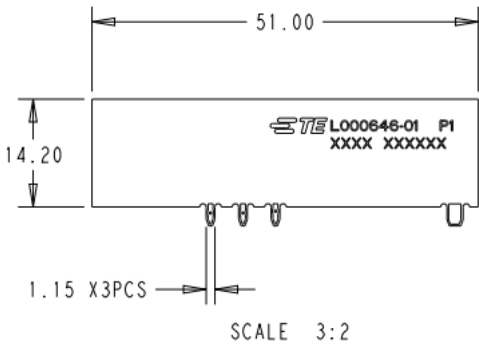

Dimensions: mm
 Diagram is not to scale

PCB ANTENNA, TAB MOUNT MIMO, 1557-7125MHz (51.0 x 14.2 x 1.61mm)

Standard Antenna Solutions

PACKAGING

L000646-01

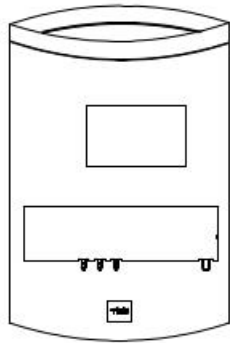
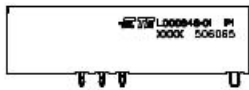

150pcs/BAG

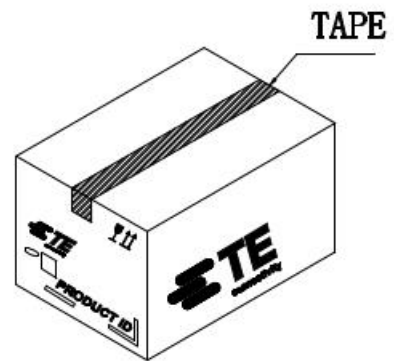
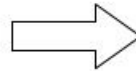
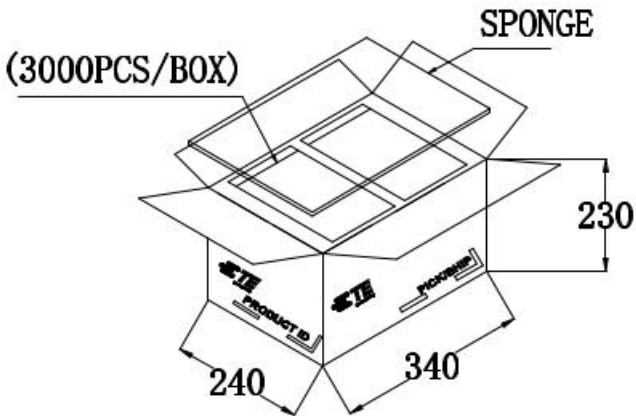

PACKAGING

L000646-80

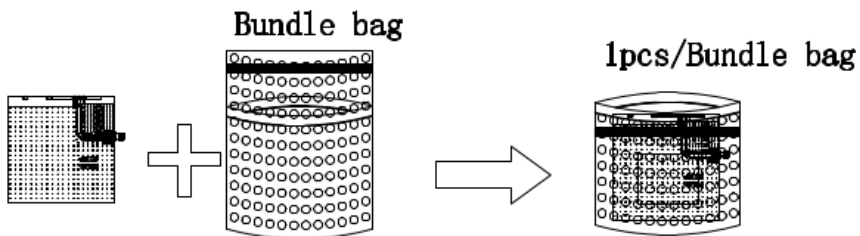

Each bag contains 10pcs

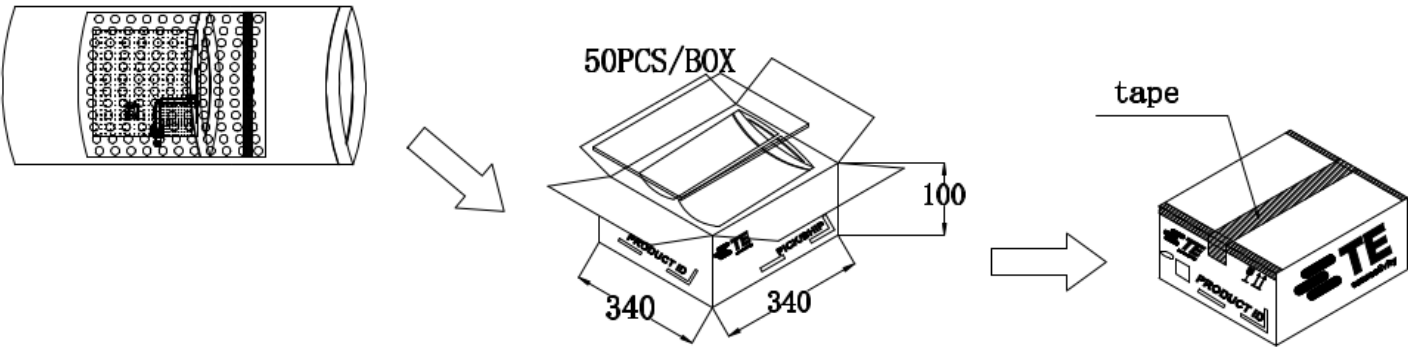

PCB ANTENNA, TAB MOUNT MIMO, 1557-7125MHz (51.0 x 14.2 x 1.61mm)

Standard Antenna Solutions

TE TECHNICAL SUPPORT CENTER

USA:	+1 (800) 522-6752
Canada:	+1 (905) 475-6222
Mexico:	+52 (0) 55-1106-0800
Latin/S. America:	+54 (0) 11-4733-2200
Germany:	+49 (0) 6251-133-1999
UK:	+44 (0) 800-267666
France:	+33 (0) 1-3420-8686
Netherlands:	+31 (0) 73-6246-999
China:	+86 (0) 400-820-6015

For phone numbers in other countries, go to te.com/support-center

te.com

TE Connectivity, TE Connectivity (logo) are trademarks. All other logos, products and/or company names referred to herein might be trademarks of their respective owners.

The information given herein, including drawings, illustrations and schematics which are intended for illustration purposes only, is believed to be reliable. However, TE Connectivity makes no warranties as to its accuracy or completeness and disclaims any liability in connection with its use. TE Connectivity's obligations shall only be as set forth in TE Connectivity's Standard Terms and Conditions of Sale for this product and in no case will TE Connectivity be liable for any incidental, indirect or consequential damages arising out of the sale, resale, use or misuse of the product. Users of TE Connectivity products should make their own evaluation to determine the suitability of each such product for the specific application. Antenna performance may vary. TE is a component manufacturer, and customer and/or end-user is responsible for all end-use compliance and regulatory requirements

© 2024 TE Connectivity Ltd. family of companies All Rights Reserved.

09/2024