

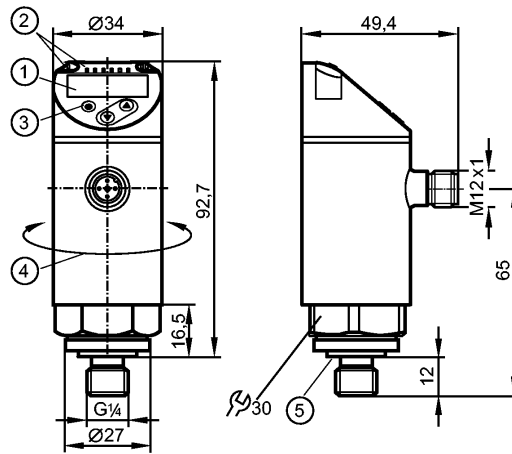

PN2596
PN-2.5-REG14-MFRKG/US/ V

Pressure sensors



- 1: 4-digit alphanumeric display / alternating indication of red and green
- 2: LEDs (display unit / switching status)
- 3: Programming button
- 4: Upper part of the housing can be rotated by 345°
- 5: Process connection sealing FKM / DIN 3869



Product characteristics

Electronic pressure sensor

M12 connector

Function programmable

Measuring element: ceramic-capacitive pressure measuring cell

Process connection: G $\frac{1}{4}$ A / M5 I (according to DIN EN ISO 1179-2)

2 outputs

OUT1 = switching output

OUT2 = switching output or analogue output

4-digit alphanumeric display / alternating indication of red and green

Measuring range: -0.125...2.5 bar / -1.8...36.25 psi / -12.5...250 kPa

Application

Application

Type of pressure: relative pressure
Group 2 fluids according to the Pressure Equipment Directive (PED),
group 1 fluids on request

Pressure rating	20 bar	290 psi	2000 kPa
Bursting pressure min.	50 bar	725 psi	5000 kPa
Vacuum resistance [mbar]	-1000		
Medium temperature [°C]	-25...80		

Electrical data

Electrical design

DC PNP/NPN

Operating voltage [V]

18...30 DC ¹⁾

Current consumption [mA]

< 35

Insulation resistance [M Ω]

> 100 (500 V DC)

Protection class

III

Reverse polarity protection

yes

Outputs

Output

2 outputs

OUT1 = switching output

OUT2 = switching output or analogue output

Output function

2 x normally open / closed programmable or 1 x normally open / closed programmable
+ 1 x analogue (4...20 mA / 0...10 V; scaleable 1:5)

Current rating [mA]

250

Voltage drop [V]

< 2

PN2596 - Electronic pressure sensor - eclass: 27201302 / 27-20-13-02

Short-circuit protection	pulsed		
Overload protection	yes		
Switching frequency [Hz]	≤ 500		
Analogue output	4...20 mA; 0...10 V		
Max. load [Ω]	4...20 mA: max. 500		
Min. load resistance [Ω]	0...10 V: min. 2000		
Measuring / setting range			
Measuring range	-0.125...2.5 bar	-1.8...36.25 psi	-12.5...250 kPa
Setting range			
Set point, SP	-0.11...2.5 bar	-1.6...36.25 psi	-11...250 kPa
Reset point, rP	-0.12...2.49 bar	-1.75...36.1 psi	-12...249 kPa
Analogue start point, ASP	-0.125...2 bar	-1.8...29 psi	-12.5...200 kPa
Analogue end point, AEP	0.375...2.5 bar	5.45...36.25 psi	37.5...250 kPa
in steps of	0.005 bar	0.05 psi	0.5 kPa
Accuracy / deviations			
Accuracy / deviations (in % of the span) Turn down 1:1			
Switch point accuracy	< ± 0.4		
Characteristics deviation *)	< ± 0.25 (BFSL) / < ± 0.5 (LS)		
Hysteresis	< ± 0.1		
Repeatability **)	< ± 0.1		
Long-term stability ***)	< ± 0.05		
Temperature coefficients (TEMPCO) in the temperature range -25...80° C (in % of the span per 10 K)			
Greatest TEMPCO of the zero point	0.2		
Greatest TEMPCO of the span	0.2		
Reaction times			
Power-on delay time [s]	0.3		
Min. response time switching output [ms]	< 1.5		
Delay time programmable dS, dr [s]	0...50		
Damping for the switching output (dAP) [s]	0...4		
Damping for the analogue output (dAA) [s]	0...4		
Response time analogue output [ms]	< 3		
Integrated watchdog	yes		
Software / programming			
Programming options	hysteresis / window function; NO / NC; on delay, off delay; damping; display unit; current/ voltage output		
Interfaces			
IO-Link device			
Transfer type	COM2		
IO-Link revision	1.1		
SDCI standard	IEC 61131-9		
IO-Link device ID	464 d / 00 01 d0 h		
Profiles	Smart Sensor: Process Data Variable; Device Identification, Device Diagnosis		
SIO mode	yes		
Required master port class	A		
Process data analogue	1		
Process data binary	2		
Min. process cycle time [ms]	2.3		
Environment			
Ambient temperature [°C]	-25...80		
Storage temperature [°C]	-40...100		
Protection	IP 65 / IP 67		
Tests / approvals			
Pressure equipment directive	97/23/EG: Sound engineering practice		
EMC	DIN EN 61000-6-2		

PN2596 - Electronic pressure sensor - eclass: 27201302 / 27-20-13-02

	DIN EN 61000-6-3
Shock resistance	DIN EN 60068-2-27 50 g (11 ms)
Vibration resistance	DIN EN 60068-2-6 20 g (10...2000 Hz)
MTTF [Years]	138
UL approval number	J012
Mechanical data	
Process connection	G ¼ A / M5 I (according to DIN EN ISO 1179-2)
Process connection sealing	FKM (to DIN 3869)
Materials (wetted parts)	stainless steel (316L / 1.4404); Al2O3 (ceramics); FKM
Housing materials	stainless steel (316L / 1.4404); PBT+PC-GF 30; PBT-GF 20; PC
Switching cycles min.	100 million
Tightening torque [Nm]	25...35 (recommended tightening torque ²⁾)
Restrictor element integrated	no (can be retrofitted)
Weight [kg]	0.263
Displays / operating elements	
Display	Display unit 3 x LED green (bar, psi, MPa) Switching status 2 x LED yellow 4-digit alphanumeric display / alternating indication Measured values of red and green
Electrical connection	
Connection	M12 connector; Gold-plated contacts
Wiring	
Core colours	
BK black	
BN brown	
BU blue	
WH white	
	<p>OUT1: switching output or IO-Link OUT2: switching output or 4...20 mA / 0...10 V Colours to DIN EN 60947-5-2</p>
Remarks	
Remarks	<p>*) BFSL = Best Fit Straight Line / LS = Limit Value Setting **) with temperature fluctuations < 10 K ***) in% of the span / 6 months 1) to EN50178, SELV, PELV 2) Depends on lubrication, seal and pressure rating</p>
Pack quantity [piece]	1