

Datasheet

RS Pro 3.7V Li-Po Rechargeable Battery, 2000mAh

RS Stock Number: 125-1266

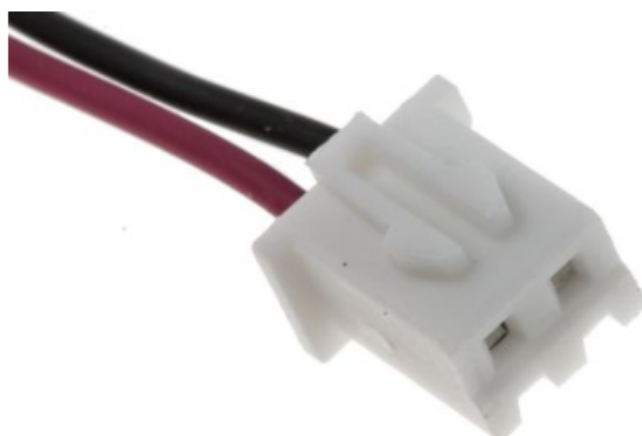

1. Scope

This specification shall be applied to polymer Li-ion Rechargeable Battery manufactured by RS Component.

2. Basic Product Characteristics

No.	Item	Characteristics
3.1	Nominal Capacity	2000mAh
	Minimum Capacity	2000mAh
3.2	Nominal Voltage	3.7V
3.3	Impedance	$\leq 150\text{m}\Omega$ (AC impedance @1kHz, 50% SOC, (23±2°C))
3.4	Limited Charge Voltage	$4.20^{+0.03}_{-0.02}\text{V}$
3.5	Discharge Cut-off Voltage	3.0V
3.6	Standard Charge	0.2C ₅ A (400mA) CC(constant current) charge to Charge Limited Voltage, then CV(constant voltage) charge till charge current decline to End-of-Charge Current at 23±2°C
3.7	Standard Discharge	0.2C ₅ A (400mA) discharge to the Discharge Cut-off Voltage at 23±2°C
3.8	Maximum Continuous Charge Current	0.5C ₅ A (1000mA)
3.9	Maximum Continuous Discharge Current	1C ₅ A (2000mA)
3.10	Operating Temperature Range	Charge 0 ~ 45°C
		Discharge -20 ~ 60°C
3.11	Storage Temperature Range	-20 ~ 60°C ≤1month ; -20 ~ 45°C ≤3months ; -20 ~ 30°C ≤12months (50±10%) SOC
	Operating and Storage Humidity Range	45~75% RH
3.12	Weight	40.0g

3. External Dimension

Item	Dimension (mm)
T	Max 7.0
W	Max 43.3
L1	Max 62.0
L2	8±1
M	14±1.5
N	4.0±0.2

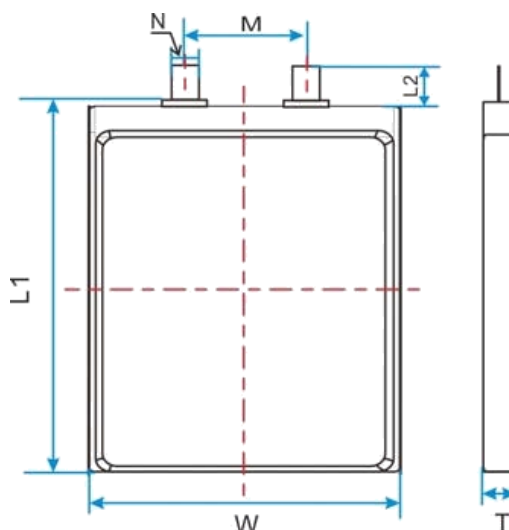

4. Basic Electrical Characteristics

No.	Items	Criteria	Test Method
6.1	Open Circuit Voltage	3.75V~3.95V	Measure with voltmeter.
6.2	Rated Capacity	≥2000mAh	Standard Discharge after Standard Charge and rest 10min.
6.3	1C ₅ A Discharge Capacity	≥90%×Rated Capacity	1C ₅ A discharge to the Discharge Cut-off Voltage after Standard Charge and rest 10min.
6.4	Temperature Characteristics	Discharge Capacity : 55°C:≥85%×Rated capacity ; 0°C:≥80%×Rated capacity ; -10°C:≥60%×Rated capacity	After Standard Charge, the cell is stored at -10 ± 2°C for 4hours, and then at the same temperature 0.2C ₅ A discharges to the Discharge Cut-off Voltage. According to this procedure, test 0 ± 2°C, 55 ± 2°C discharge capacity, respectively.
6.5	Storage Characteristics	Retention Capacity: ≥85% ×Rated Capacity	After Standard Charge, the cell is stored for 28 days , and then 0.2 C ₅ A discharges to the Discharge Cut-off Voltage to test retention capacity.
6.6	Cycle Life	Discharge Capacity(301 th cycle)≥Rated Capacity×80%	A cycle is defined as a Standard Charge, 10 minute-rest and Standard Discharge.The cell is to be cycled for 301 times.

Remark 1: All tests mentioned in this specification should be tested at $23 \pm 2^{\circ}\text{C}$ and the standard air pressure.

5. Safety Characteristics

No.	Items	Criteria	Test Method
7.1	Overcharge	No fire. No explosion.	3C ₅ A CC charge to 4.8V after Standard Discharge, then CV Charge till current decline to End-of-Charge Current or CV time is more than 7hours.
7.2	Short-Circuit	No fire. No explosion. The temperature of the cell shall not exceed 150°C .	Rest for 30minutes at $55 \pm 2^{\circ}\text{C}$ after Standard Charge, then short-circuit cells by connecting the positive and negative terminals with a circuit load having a resistance load(copper wire) of $80 \pm 10\text{m}\Omega$. Test can be terminated when cell surface temperature has returned to $\pm 10^{\circ}\text{C}$ of environment temperature.
7.3	Heating	No fire. No explosion.	The cell is to be heated in a gravity convection or circulating air oven after Standard Charge. The temperature of the oven is to be raised at a rate of $5 \pm 2^{\circ}\text{C}$ per minute to a temperature of $130 \pm 2^{\circ}\text{C}$ and remain for 10 minutes.

Remark 2: All safety characteristics are carried out by specialized personnel familiar with Li-ion knowledge or under instruction of our technical personnel after detailed consultation.

6. Reliability Characteristics

No	Items	Criteria	Test Method
8.1	Static Humidity and Temperature	Retention Capacity: $\geq 80\% \times \text{Rated Capacity}$ Recoverable Capacity $\geq 85\% \times \text{Rated Capacity}$ No deformation. No rupture. No smoke. No leakage.	After Standard Charge, the cell is stored at $40 \pm 2^{\circ}\text{C}$ and 90%-95%RH for 48hours, then rest for 2hours at $23 \pm 2^{\circ}\text{C}$. Standard Discharge to test its retention capacity, and then perform a cycle with Standard Charge and Standard Discharge procedure to test recoverable capacity.
2	Vibration	OCV $\geq 3.6\text{V}$; No rupture. No leakage. No fire. No explosion.	After Standard Charge, the cell is fixed to vibration table and subjected to vibration cycling that the frequency is to be varied at the rate of 1Hz per minute between 10Hz and 55Hz, the excursion of the vibration is 1.6mm. The cell shall be vibrated for 30 minutes per

			axis of XYZ axes.
8.3	Drop	Retention Capacity: $\geq 90\% \times \text{Rated Capacity}$; No rupture. No leakage. No fire. No explosion.	After Standard Charge, the cell is to be dropped from a height of 1 meter onto board ground for 6 times, then test the retention capacity with Standard Discharge.

7. Matters needing attention

Strictly observes the following needing attention. RS Component will not be responsible for any accident occurred by handling outside of the precautions in this specification.

8. External Dimension Drawing PACK

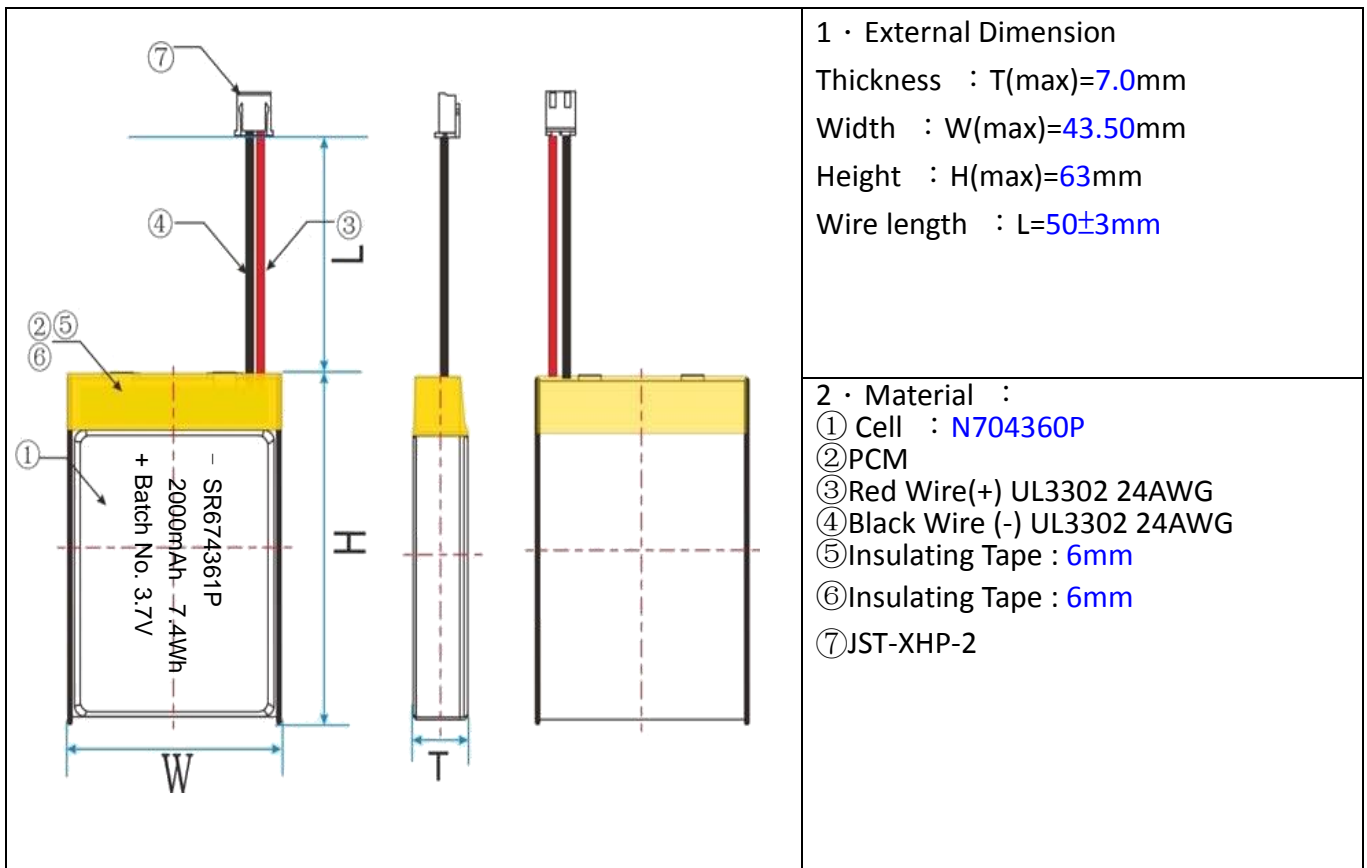

11.Parameter of PCM

11.1 List of Parameter

Parameter	Min.	Typ.	Max	Unit
Overcharge Detection Voltage	4.255	4.280	4.305	V
Overcharge Detection Delay Time	50	100	150	ms
Over discharge Detection Voltage	2.85	2.90	2.98	V
Over discharge Detection Delay Time	10	25	40	ms
Discharge Over Current Detection	2.0	4	6	A
Over Current Detection Delay Time	5	10	15	ms
Short circuit Detection Delay Time		500	700	μ s
Current Consumption in Normal	1.0	3.0	6.0	μ A
Impedance	10	35	65	m Ω

11.2 List of PCB BOM

No.	Element Code	Part Number	Type/Specification	Qty.
1	U1	Protection IC	HY211-GB	1
2	Q1	MOSFET	SM8205A	1
3	R1	Resistor	100 Ω /±5%	1
4	R2	Resistor	2K Ω /±5%	1
5	C1	Capacitor	C1005X7R1H104	1
6		PCB		1

11.3 Circuit Diagram

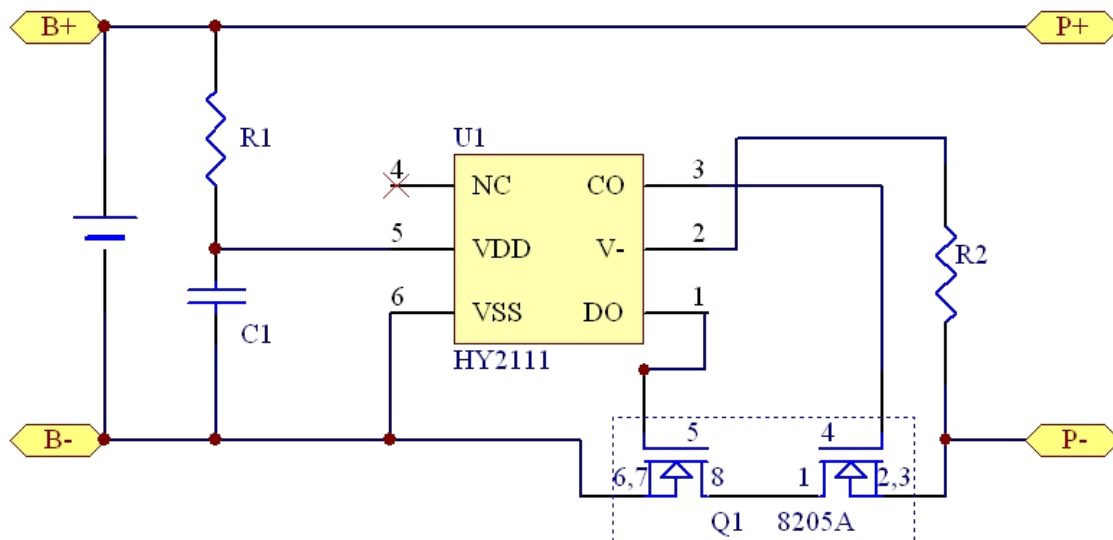

Caution!

- Before using the cell, be sure to read the user's manual and cautions on handling thoroughly.
- Charge with specific charger according to product specification. Charge with CC/CV model. Reverse charging is prohibited for it will deteriorate the cell performance and lead to safety issues such as heat and leakage.
- Keep batteries out of reach of children to avoid being swallowed.
- If children use the cell, their guardians should explain the proper handling.
- Batteries have life cycles. If cell powers equipment much shorter time than usual, please replace the cell with a new one.
- When not using cell for long terms, remove it from the equipment and store in a place with low humidity and low temperature.
- While the cell pack is charged, used and stored, keep it away from places/objects with static electric.
- If the terminals of cell become dirty, clean it with dry cloth before using.
- Cell would be over-discharged by its self-discharge characteristics in case the battery is not used for long time. In order to prevent over-discharging, the battery shall be charged periodically to maintain between 3.7V and 3.9V. Cell is to be stored in a condition as Item. 3.11 and 3.12.